

Starrett®

Precision, Quality, Innovation

METROLOGY SYSTEMS

Vision Measurement
Systems

Video Inspection Systems

Optical Comparators

Software



PRECISION, QUALITY, INNOVATION

For more than 135 years, manufacturers, builders and craftsmen worldwide have depended upon tools from the L.S. Starrett Company to ensure the consistent quality of their manufacturing processes.

They know that the Starrett name on Optical Comparators, Vision and Multi-Sensor Metrology systems, precision hand tools, gage blocks, hand tools, power tool accessories, saws, laser measurement, force and material testing means exceptional quality, innovative products and expert technical assistance.

With strict quality control, state-of-the-art equipment and an ongoing commitment to producing products with superior quality, the 5,000 plus products in today's Starrett line continue to be the most accurate, robust and durable tools available.

This catalog features Starrett Metrology Equipment, their applications and characteristics.

VISION MEASUREMENT SYSTEMS

Video-based measurement systems combine high-resolution images, powerful intuitive software and precision mechanical platforms to deliver superb accuracy and repeatable measurement results for a wide range of precision measurement applications

07



VIDEO INSPECTION SYSTEMS

The KMR video based microscopes are a family of versatile and affordable inspection and measurement systems.

29



OPTICAL COMPARATORS

Optical comparators provide a time tested, cost effective solution for non-contact measurement. Optical comparators are used for an exceptionally wide range of dimensional measurement and inspection applications.

33



SOFTWARE

Starrett offers multiple software and metrology readout solutions to meet the needs of Quality Departments, Engineering and Manufacturing alike.

59

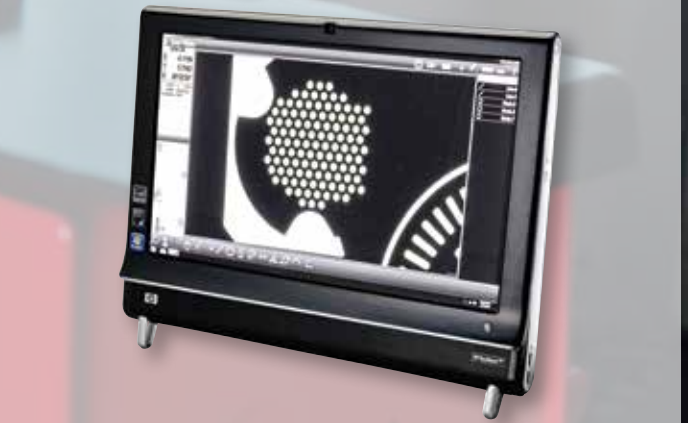

METROLOGY SYSTEMS

FACTORIES AROUND THE WORLD



1-Athol, Massachusetts, USA



2-Laguna Hills, California, USA



3-Waite Park, Minnesota, USA



4-Cleveland, Ohio, USA

FACTORIES



 Factories and Distribution Centers

 Starrett Distribution Centers and Offices



5-Mount Airy, North Carolina, USA



6-Columbus, Georgia, USA



7-Itu, São Paulo, Brazil



8-Jedburgh, Scotland



9-Suzhou, China





PRECISION MAKES THE DIFFERENCE

FOR OVER 135 YEARS, WITH INNOVATIVE TECHNOLOGIES.

More than 5,000 products including precision tools, vision systems, force measurement systems, non-contact measurement systems, optical comparators, band saw blades, band saw machines, hand tools and power tools accessories.

Read more: www.starrett.com



Starrett®

(978) 249-3551 • starrett.com

Follow us!



Starrett



Our broad range of metrology systems are ideal for use in QC labs, research, engineering, and manufacturing environments where small to large scale high-precision measurement is critical.

Many systems are available in either manual or CNC configurations.

VISION SYSTEMS

MANUAL VISION METROLOGY SYSTEMS

MVR

MVR200 AND MVR300

The MVR Manual Vision Metrology Systems are ideal for individual measurements or short runs. They are available with dedicated zoom optics or a quick-change bayonet lens mount which accepts interchangeable zoom optics or telecentric lenses for micron-level resolution and accurate field-of-view (FOV) measurements. These can encompass an entire small part up to 2.00 x 1.50" or a feature of a larger part and be seamlessly integrated with stage motion to measure parts with a length up to 8" (MVR200) or 12" (MVR300). The operator interface is the MetLogix™ M3 FOV software that displays a live video image of the part plus geometry tools and digital readings. The image of the part can be resized using zoom, and measurements can be taken by simply touching a feature on the touch-screen.

MVR hardware features include a granite base for maximum stability, precision linear guides for smooth, accurate stage motion and a motorized Z-axis with variable speed control.

MVR OPTICS

Optical Parameters	Interchangeable Telecentric Optics						6.5:1 Zoom Optics	
	Interchangeable		Dedicated		Interchangeable		Dedicated	
Optical magnification on CCD	0.30x	0.50x	0.80x	1.0x	2.0x	4.0x	0.7x to 4.5x	0.47x to 3.0x
Total magnification on monitor	13x	22x	36x	45x	89x	178x	31x to 200x	31x to 200x
Field of view	.94" (24mm)	.55" (14mm)	.35" (9mm)	.27" (7mm)	.14" (3.5mm)	1.8" (1.8mm)	.39" to .06" (10 to 1.6mm)	.39" to .06" (10 to 1.6mm)
Working distance	4.3" (110mm)	4.3" (110mm)	4.3" (110mm)	4.3" (110mm)	4.3" (110mm)	4.3" (110mm)	3.47" (88mm)	3.47" (88mm)
Camera CCD	1/1.8"	1/1.8"	1/1.8"	1/1.8"	1/1.8"	1/1.8"	1/1.8" CCD Array	1/3" CCD Array

OPERATOR INTERFACE

Feature	M3 DXF/FOV Software
M3 controller housed in Z column	x
Wi-Fi network connectivity	x
Video edge detection	x
X-Y-Z measurements	x
2D geometric constructs plus height	x
FOV measurements integrated with X-Y stage motion	x
CAD file import and export	x
Automatic comparison of measurements to CAD files	x
Software developer	MetLogix™



FEATURES AND SPECIFICATIONS

- Z travel: 8" (200 mm) with 2.0x auxiliary lens
- Manual X-Y positioning via hand wheels
- Motorized Z-axis positioning with variable speed control
- MetLogix™ M3 metrology software
- Video edge detection (VED)
- Field-of-view (FOV) measurements integrated with stage motion
- Renishaw scales for .00002" (0.5µm) of X and Y resolution
- Color digital video camera
- Collimated LED sub-stage illumination
- Ring light LED surface illumination
- Granite base

OPTIONS

- Optional dedicated or interchangeable 6.5:1 zoom lens
- Quick-change bayonet lens mount for interchangeable zoom or telecentric optics
- Auxiliary Lenses for Zoom Optics: 0.5x, 1.5x and 2.0x
- Interchangeable telecentric lens magnifications including - .3x, .5x, .8x, 1.0x, 2.0x and 4.0x
- DXF/FOV option for automatic comparison to CAD files
- Modular system workstation
- Calibration standards

MVR DIMENSIONS

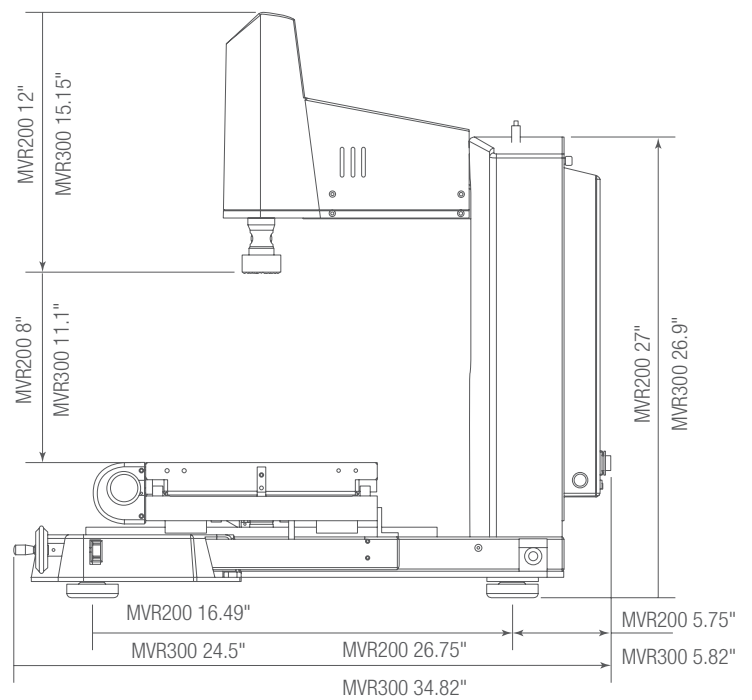
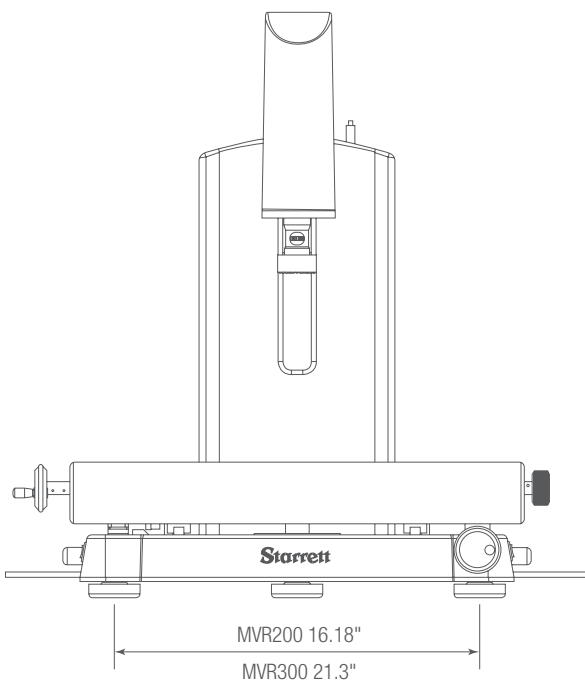

SPECIFICATIONS

	MVR200	MVR300
Net Weight	145lbs 90kg	230lbs 113kg
Shipping Weight	250lbs 115kg	300lbs 135kg
X-Y Travel	8 x 4" 200 x 100mm	12 x 8" 300 x 200mm
X-Y-Z Accuracy	2.5µm + 5L/1000	2.5µm + 5L/1000



AUTOMATIC VISION METROLOGY SYSTEMS



AV300, AV350 AND AV450

The AV Automatic Vision Metrology Systems provide accurate 3-axis measurement capability (X-Y-Z) with hi-resolution video zoom optics and optional touch probe. The systems can be pre-programmed (CNC) for repetitive part inspection, or driven manually via a joystick and trackball for individual measurements. Superb performance is achieved by a highly stable mechanical design, with precision linear bearings. Throughput is maximized with either QC5000 or MetLogix™ M3 software controlling all features of Video Edge Detection (VED) and multiple channel Fiber Optic or LED illumination.

These automatic vision systems are ideal for quality assurance, inspection, and production runs. Flexible and powerful, the AV series allows users to cost effectively achieve maximum throughput of their inspection process. Measured data is effectively archived or networked to other devices.

AV OPTICS

Optical Parameters	Dedicated Zoom Optics	
	6.5:1	12:1
Optical magnification on CCD	0.47x to 3.0x	1.4x to 4.7x
Total magnification on monitor	31x to 198x	26x to 310x
Field of view width	.39" to .06" (10 to 1.6mm)	.44" to .047" (11 to 1.2mm)
Working distance	3.47" (88mm)	3.38" (86mm)
Camera CCD	1/3"	1/3"

OPERATOR INTERFACE

Feature	MetLogix™ M3	QC5000
24" (60cm) touch-screen monitor and PC	x	
External motion control unit	x	x
Windows®-based operating system	x	x
Wi-Fi network connectivity	x	x
CAD file import and export	x	x
Video edge detection	x	x
X-Y-Z measurements	x	x
2D geometric constructs	x	x
3D geometric constructs		x
CNC control capability	x	x
Report generation and archiving	x	x
Optional DXF/FOV software	x	
Software developer	MetLogix™	Metronics/Heidenhain

AV350 shown with system stand and control cart - included



AV300



FEATURES AND SPECIFICATIONS

- CNC operation or manual operation via joystick and trackball
- Reading resolution 4µin (0.1µm)
- MetLogix™ M3 metrology software
- Magnification on 24" monitor, 1:1 pixel setting: 37x to 240x with 6.5:1 zoom, 25x to 240x with 12:1 zoom
- Multiple channel Fiber Optic or LED Illumination
- Cast aluminum base for AV300. Granite base on AV350 & AV450
- 1.3 mega-pixel color digital video camera

OPTIONS

- 6.5:1 or 12:1 dedicated zoom optics
- Optional 0.5x, 1.5x and 2.0x auxiliary lenses
- Renishaw touch probe kit
- 2 or 4 bay touch probe change rack
- Ergonomic workstation (machine stand and control cart standard (with AV350))
- LED dark-field quadrant illuminator
- DXF/FOV option for automatic comparison to CAD files
- Calibration standards

AV300 DIMENSIONS

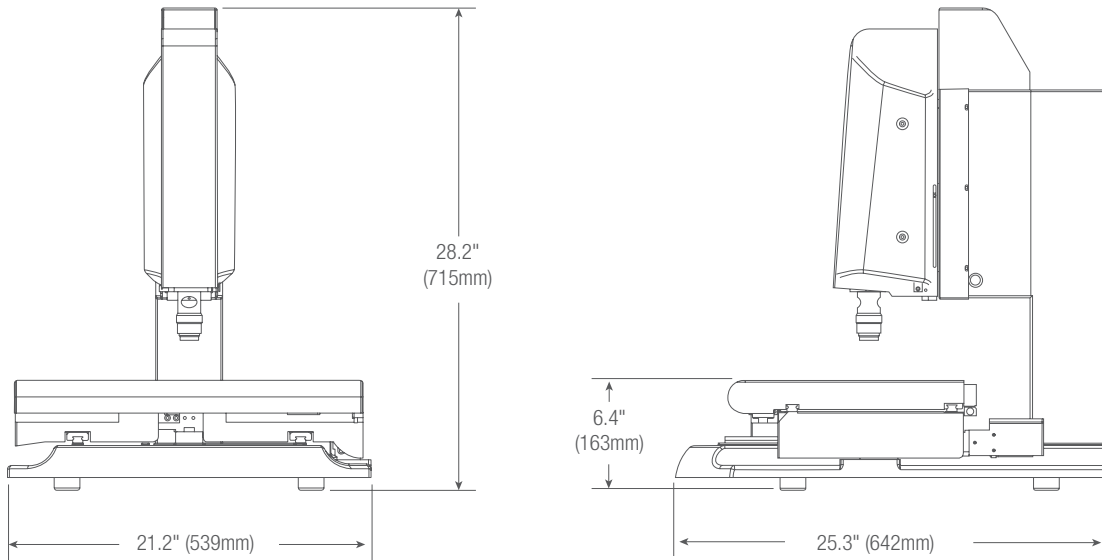

AV350 / AV450

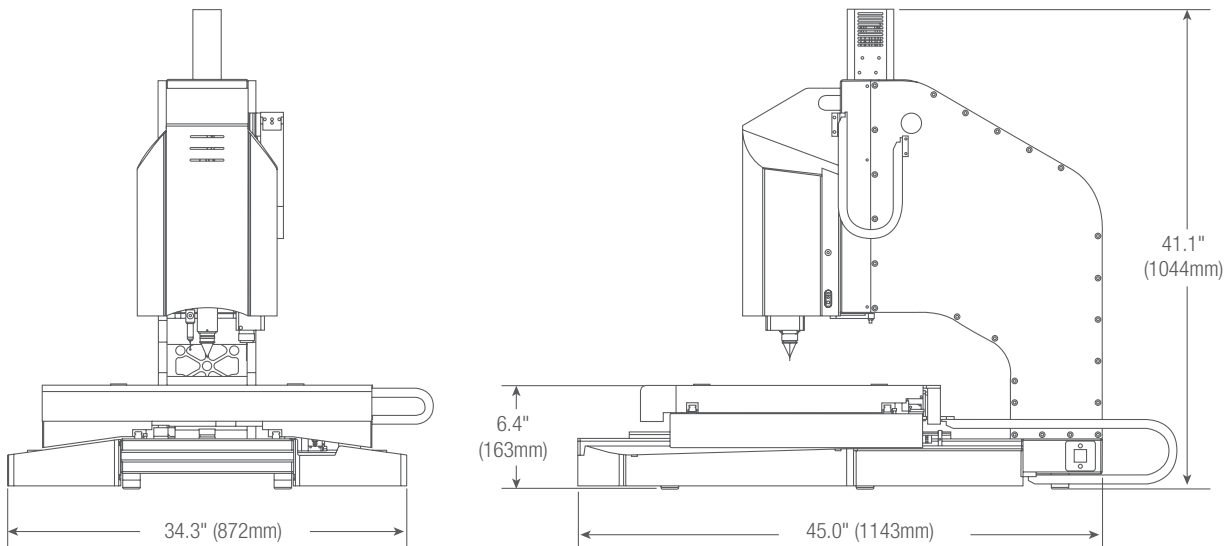

SPECIFICATIONS

	AV300	AV350	AV450
Net Weight	125lbs 57kg	409lbs 185kg	409lbs 185kg
Shipping Weight	345lbs 157kg	1,275lbs 579kg	1,275lbs 579kg
X-Y-Z Travel	12 x 6 x 5.5" 300 x 150 x 140mm	14 x 14 x 8" 350 x 350 x 200mm	18 x 14 x 8" 450 x 350 x 200mm
X-Y Accuracy (µm)	E2 = 1.9µm + 5L/1000	E2 = 2.5µm + 5L/1000	E2 = 2.5µm + 5L/1000
Z Accuracy (µm)	E1 = 2.5µm + 5L/1000	E1 = 2.5µm + 5L/1000	E1 = 2.5µm + 5L/1000

AUTOMATIC VISION METROLOGY SYSTEMS

AVR

AVR200 AND AVR300

The AVR CNC Automatic Vision Metrology Systems are ideal for repetitive measurements and automatic comparison to CAD files. Available with dedicated interchangeable telecentric lenses for micron-level resolution and accurate field-of-view (FOV) measurements. These can encompass an entire small part up to 2.00 x 1.50" or a feature of a larger part and be seamlessly integrated with stage motion to measure parts with a length up to 8" (AVR200) or 12" (AVR300). MetLogix™ M3 software capabilities include 3-axis measurements and 2D geometric constructs (points, lines, angles, rectangles). Systems are also touch probe compatible.

AVR OPTICS

Optical Parameters	Telecentric Optics						Dedicated Zoom Optics	
	0.30x	0.50x	0.80x	1.0x	2.0x	4.0x	6.5:1*	12:1
Optical magnification on CCD	0.30x	0.50x	0.80x	1.0x	2.0x	4.0x	0.47x to 3.0x	1.4x to 4.7x
Total magnification on monitor	13x	22x	36x	45x	89x	178x	31x to 198x	26x to 310x
Field of view width	.94" (24mm)	.55" (14mm)	.35" (9mm)	.27" (7mm)	.14" (3.5mm)	.07" (1.8mm)	.39" to .06" (10 to 1.6mm)	.44" to .047" (11 to 1.2mm)
Working distance	4.3" (110mm)	4.3" (110mm)	4.3" (110mm)	4.3" (110mm)	4.3" (110mm)	4.3" (110mm)	3.47" (88mm)	3.47" (86mm)
Camera CCD	1/1.8"	1/1.8"	1/1.8"	1/1.8"	1/1.8"	1/1.8"	1/3"	1/3"

* 6.5:1 available as interchangeable zoom optics

OPERATOR INTERFACE

Feature	All-in-One PC with M3 DXF/FOV Software
M3 controller housed in Z column	x
24" (60cm) color graphic touch-screen monitor and PC	x
Windows®-based operating system	x
Wi-Fi network connectivity	x
Video edge detection	x
X-Y-Z measurements	x
2D geometric constructs plus height	x
FOV measurements integrated with X-Y stage motion	x
CAD file import and export	x
Automatic comparison of measurements to CAD files	x
Software developer	MetLogix™





FEATURES

- Z travel: 8" (200 mm) with 2.0x auxiliary lens
- Full CNC X-Y-Z positioning or motorized manual positioning using a pendant with joystick and trackball
- Video edge detection (VED)
- Field-of-view (FOV) measurements integrated with stage motion
- Renishaw scales for .00002" (0.1µm) of X,Y and Z axis
- Color digital video camera
- Collimated LED sub-stage illumination
- Ring Light LED surface illumination
- Granite base

OPTIONS

- Dedicated 6.5:1 or 12:1 CNC zoom optics
- Quick-change bayonet lens mount for telecentric optics (FOV Model)
- Interchangeable bayonet mount lenses - 0.30x, 0.50x, 0.80x, 1.0x, 2.0x, 4.0x telecentric optics and 6.5-1 manual zoom lens
- 0.5x, 1.5x and 2.0x auxiliary lenses for zoom optics
- Renishaw touch probe kit
- 2 or 4 Bay touch probe change rack
- Quadrant LED surface illumination for zoom optics
- DXF/FOV option for automatic comparison to CAD files
- Modular system workstation
- Calibration standards
- Part fixtures and work holding devices

AVR DIMENSIONS

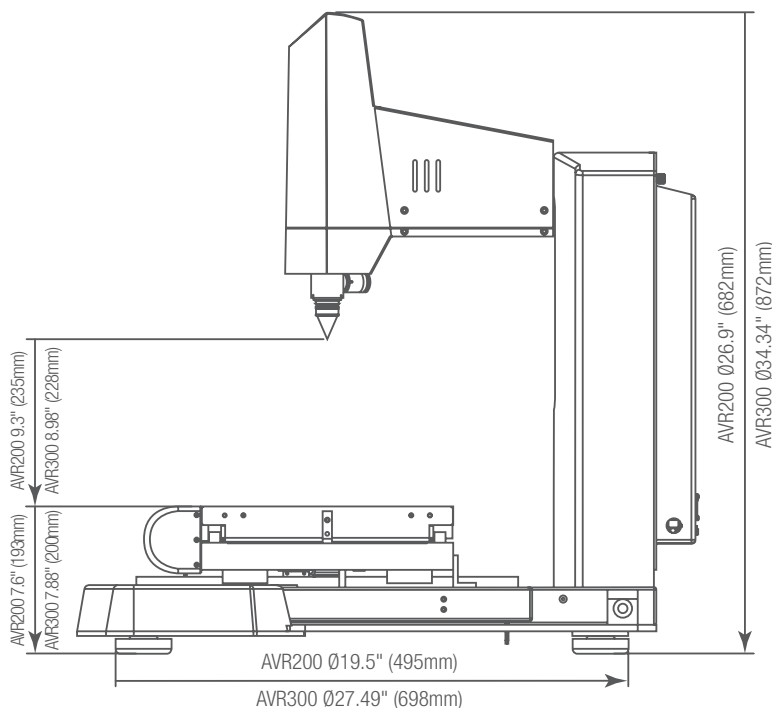
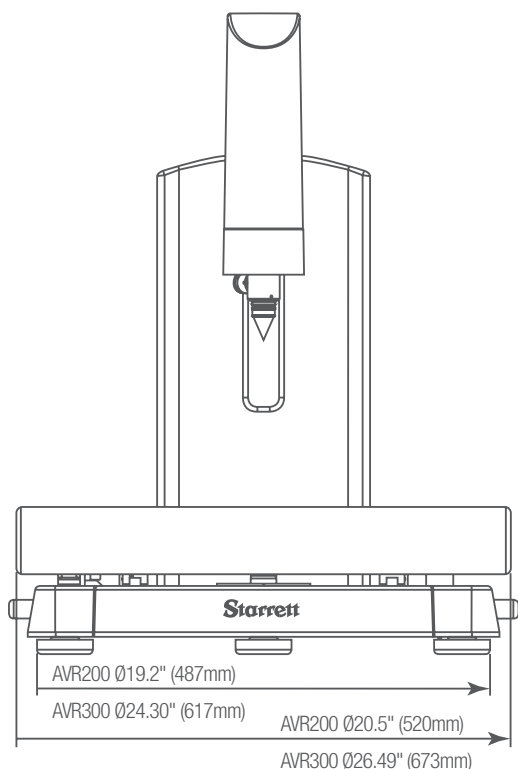

SPECIFICATIONS

	AVR200	AVR300
Net Weight	145lbs 66kg	225lbs 102kg
Shipping Weight	250lbs 115kg	300lbs 135kg
Dimensions (H x W x D)	34 x 20.5 x 27" 863 x 520 x 685mm	34 x 29.2 x 35" 865 x 740 x 890mm
X-Y-Z Travel	8 x 4 x 8" 200 x 100 x 200mm	12 x 8 x 8" 300 x 200 x 200mm
X-Y Accuracy	1.9µm + 5L/1000	1.9µm + 5L/1000
Z Accuracy	2.5µm + 5L/1000	2.5µm + 5L/1000

AUTOMATIC VISION METROLOGY SYSTEMS

AV300+

MULTI-SENSOR

An enhanced version of the popular AV300 CNC video-based measurement system. The AV300+ system improves measuring performance by utilizing a precision granite base along with an extended travel Z column, delivering 12 x 6 x 8" (300 x 150 x 200mm) X-Y-Z measuring range. The system is a servo driven motion platform for enhanced performance and includes a 12:1 zoom lens, hi-resolution digital color camera and a choice of fiber optic or LED illumination. Complete with vibration isolation and integrated machine stand, the AV300+ delivers more capability for multi-sensor requirements. The AV300+ is powered by QC5300 software to handle a variety of measuring applications. Systems are available with vision, touch probe, laser sensors and rotary fixtures.

AV+ OPTICS

Optical Parameters	Dedicated Zoom Optics
	12:1
Optical magnification on CCD	1.4x to 4.7x
Total magnification on monitor	26x to 310x
Field of view width	.44" to 0.47" (11 to 1.2mm)
Working distance	3.47" (86mm)
Camera CCD	1/3"

OPERATOR INTERFACE

Feature	QC5300
24" (60cm) color graphic touch-screen monitor and PC	x
External motion control unit	x
Windows®-based operating system	x
Wi-Fi network connectivity	x
CAD file import and export	x
Video edge detection	x
X-Y-Z measurements	x
2D geometric constructs	x
3D geometric constructs	x
CNC control capability	x
Report generation and archiving	x
Software developer	Metronics/Heidenhain



AV300+

AV300+ shown with system stand and control cart - included

FEATURES AND SPECIFICATIONS

- 12:1 Zoom Optics with co-axial illumination
- Precision Granite base construction
- System stand and control cart standard
- Touch probe compatible
- Touch probe change rack compatible
- CNC Rotary Axis compatible
- Laser Probe compatible

OPTIONS

- 0.5x, 1.5x and 2.0x auxiliary lenses for zoom optics
- Quadrant LED dark-field surface illumination
- Renishaw touch probe kit
- 2 or 4 bay touch probe change rack compatible
- Optimet laser probe
- CNC rotary axis fixture
- Calibration standards
- Part fixtures and work-holding device

AV300+ DIMENSIONS

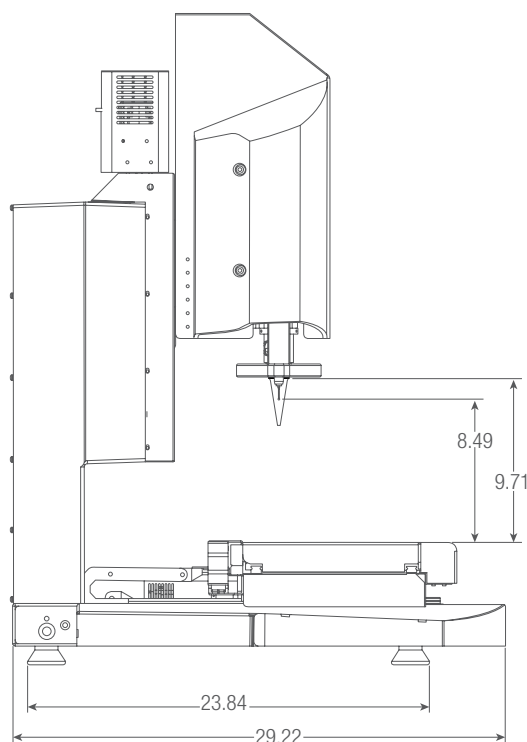
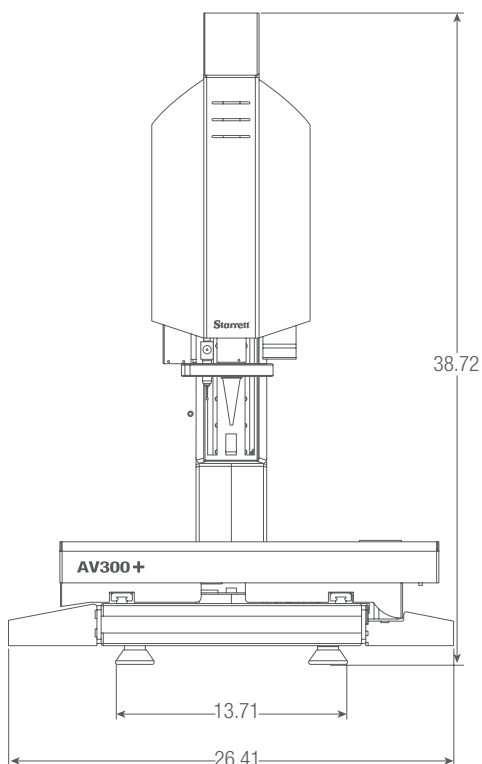

SPECIFICATIONS

	AV300+
Net Weight	210lbs
	95kg
Shipping Weight	345lbs
	157kg
X-Y Accuracy	E2 = 1.9 + 5L/1000
Z Accuracy	E1 = 2.5 + 5L/1000

AUTOMATIC VISION METROLOGY SYSTEMS

AV350+ / AV450+

MULTI-SENSOR

Offering similar attributes and performance to the AV300+ with an expanded measurement envelope of 14 x 14 x 8" (350 x 350 x 200mm), 18 x 14 x 8" (450 x 350 x 200mm) X-Y-Z measuring range for those larger part and payload measurement requirements. Systems are available with vision, touch probe, laser sensors and rotary fixtures.

AV+ OPTICS

Optical Parameters	Dedicated Zoom Optics
	12:1
Optical magnification on CCD	1.4x to 4.7x
Total magnification on monitor	26x to 310x
Field of view width	.44 to .047" (11 to 1.2mm)
Working distance	3.47" (86mm)
Camera CCD	1/3"

OPERATOR INTERFACE

Feature	QC5300
Desktop PC with monitor	X
External motion control unit	X
Windows®-based operating system	X
Wi-Fi network connectivity	X
CAD file import and export	X
Video edge detection	X
X-Y-Z measurements	X
2D geometric constructs	X
3D geometric constructs	X
CNC control capability	X
Report generation and archiving	X
Software developer	Metronics/Heidenhain





FEATURES AND SPECIFICATIONS

- 12:1 Zoom Optics with co-axial illumination
- Precision Granite base construction
- System stand and control cart standard

OPTIONS

- 0.5x, 1.5x and 2.0x auxiliary lenses for zoom optics
- Quadrant LED surface illumination for zoom optics
- Renishaw touch probe kit
- Optimet laser probe
- 2 or 4 bay touch probe change rack compatible
- CNC rotary axis fixture
- Calibration standards
- Part fixtures and work holding devices

AV350+ / AV450+ DIMENSIONS

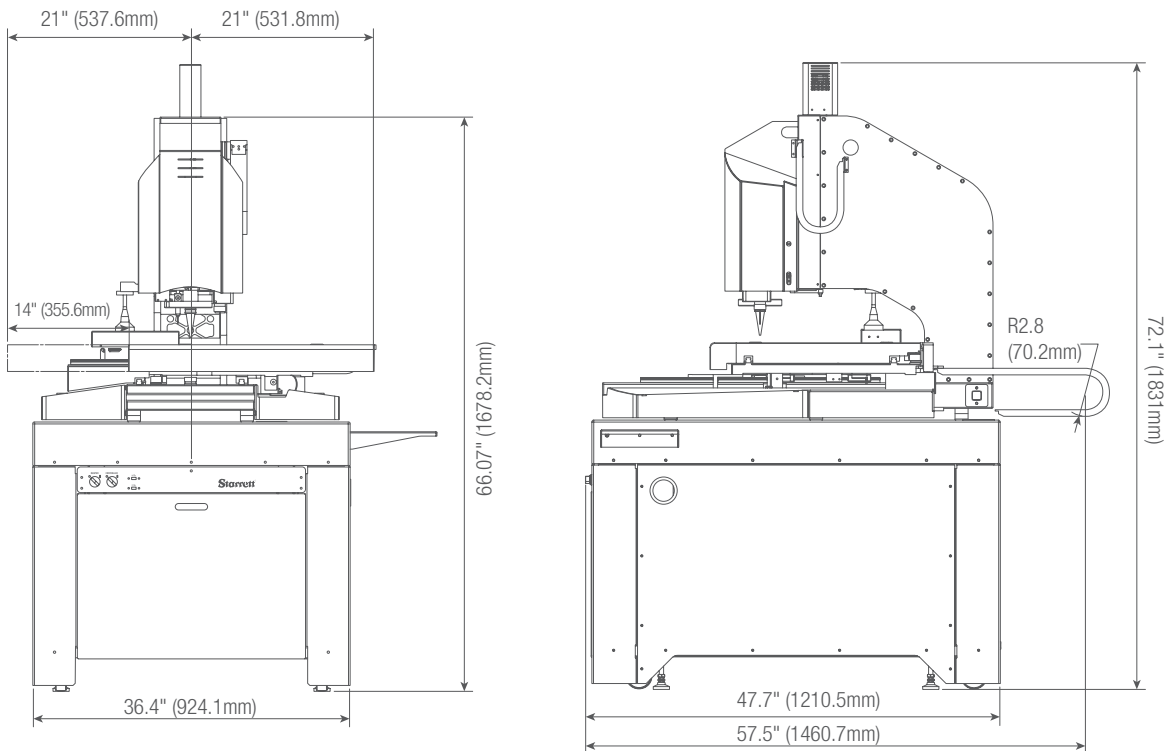

SPECIFICATIONS

	AV350+	AV450+
Net Weight	409lbs 185kg	409lbs 185kg
Shipping Weight	1,275lbs 579kg	1,275lbs 579kg
X-Y-Z Travel	14 x 14 x 8" 350 x 350 x 200mm	18 x 14 x 8" 450 x 350 x 200mm
X-Y Accuracy (µm)	E2 = 2.5µm + 5L/1000	E2 = 2.5µm + 5L/1000
Z Accuracy (µm)	E1 = 2.5µm + 5L/1000	E1 = 2.5µm + 5L/1000



LARGE FORMAT PREMIER

LF

LF AND LFM

Our LF Premier machines offer X-Y travel from 18" (460mm) to a generous 28" (711mm). Z travel is 8" (200mm), 12" (300mm option). (Larger sizes available upon request.) Increased accuracy helps you verify critical dimensions. Ideal for use in QC labs, research, engineering, or manufacturing environments.

LF models utilize air-bearing and linear motor X-Y transport for ultra smooth, high speed positioning. LFM models are equipped with precision

LF OPTICS

Optical Parameters	Dedicated Zoom Optics	
	6.5:1	12:1
Optical magnification on CCD	0.47x to 3.0x	1.4x to 4.7x
Total magnification on monitor	31x to 198x	26x to 310x
Field of view width	.39 to .06" (10 to 1.6mm)	.44 to .047" (11 to 1.2mm)
Working distance	3.47" (88mm)	3.47" (86mm)
Camera CCD	1/3"	1/3"

OPERATOR INTERFACE

Feature	MetLogix™ M3	QC5300
21.5" monitor with touch screen	x	
21.5" monitor with desktop PC	x	x
External motion control unit	x	x
Windows®-based operating system	x	x
Wi-Fi network connectivity	x	x
CAD file import and export	x	x
Video edge detection	x	x
X-Y-Z measurements	x	x
2D geometric constructs	x	x
3D geometric constructs		x
CNC control capability	x	x
Report generation and archiving	x	x
Software developer	MetLogix™	Metronics/Heidenhain



LF463

mechanical bearing linear guides driven by precision ground ball screws and servo motors.

FEATURES AND SPECIFICATIONS

- Transports are driven on air bearings by hi-speed (up to 30" per second), zero maintenance, balanced linear motors, or precision mechanical linear bearings, which are close-looped to precision hi-resolution scales in all three axes
- Adjustable ergonomic workstation including a compact control panel and standard keyboard
- Massive granite base, bridge and mechanical or air-bearing ways for superior machine stability and precision
- Choice of QC5300 or MetLogix™ M3 Software or QC5000
- 21.5" monitor with QC5300 or M3 software
- LED Surface Ring Illumination
- LED Transmitted Illumination
- LED Coaxial Illumination
- Digital Video Color Camera: 1.2 MP, 1/3" SXVGA sensor

OPTIONS

- Dedicated 6.5:1 or 12:1 CNC zoom optics
- 0.5x, 1.5x and 2.0x auxiliary lenses for zoom optics
- Quadrant LED surface illumination
- DXF/FOV option for automatic comparison to CAD designs
- 24" (60cm) touch-screen monitor for M3
- CNC rotary axis fixture
- Renishaw touch probe kit
- Touch probe spotter camera for viewing critical placement of touch probe points as well as a touch probe changing rack (with QC5300)
- Calibration standards
- Part fixtures and work holding devices

LF DIMENSIONS

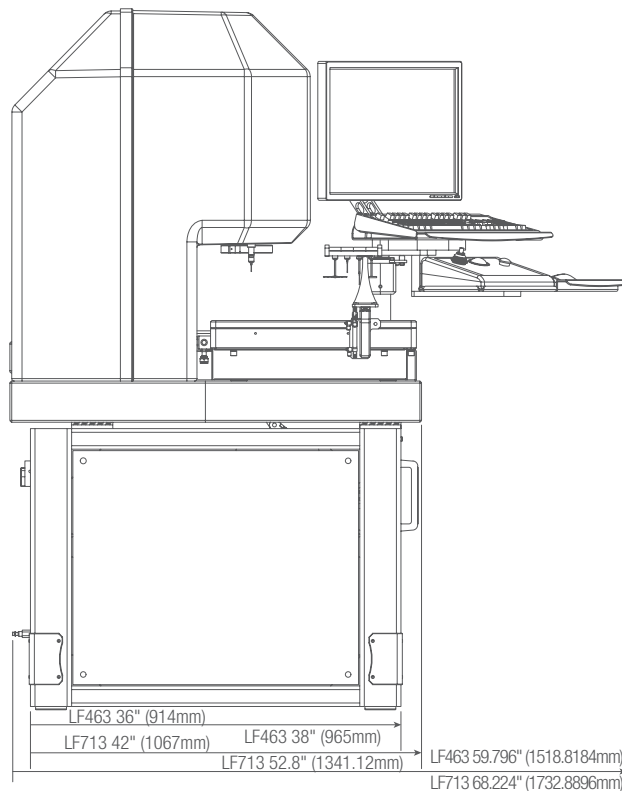
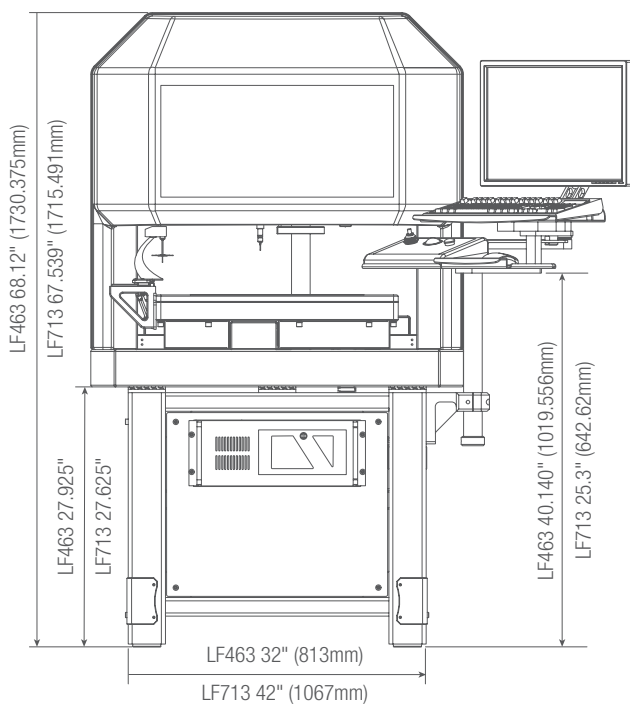

SPECIFICATIONS

Model	LF463†	LF713†	LFM463*	LFM713*
Dimensions (W x D x H)	40 x 40 x 68" (102 x 102 x 173cm)	50 x 64 x 68" (127 x 163 x 173cm)	40 x 40 x 68" (102 x 102 x 173cm)	50 x 64 x 68" (127 x 163 x 173cm)
Net Weight	1500lb (726kg)	2700lb (1225kg)	1500lb (726kg)	2700lb (1225kg)
Shipping Weight	2300lb (1043kg)	3600lb (1630kg)	2300lb (1043kg)	3600lb (1630kg)
X-Y-Z Travel	18 x 12 x 8" (460mm x 300mm x 200mm)	28 x 24 x 8" (710mm x 610mm x 200mm)	18 x 12 x 8" (460mm x 300mm x 200mm)	28 x 24 x 8" (710mm x 610mm x 200mm)
Accuracy Stage X and Y	E2=2.5 + 5L/1000	E2=2.5 + 5L/1000	E2=3.5 + 5L/1000	E2=3.5 + 5L/1000
Accuracy Stage Z	E1=2.5 + 5L/1000	E1=2.5 + 5L/1000	E1=2.5 + 5L/1000	E1=2.5 + 5L/1000

† Air Bearing

* Mechanical bearing

Larger sizes available - please contact factory.

HVR 100 FLIP

HVR

HVR100 -FLIP

The all new "HVR-Flip" from Starrett is the latest in a line of video-based measurement systems. The HVR-Flip has the unique characteristic of being used in either a vertical or horizontal format offering tremendous versatility and value.

SPECIFICATIONS

	HVR 100
Field of View	3.65" x 3.0" (92.7mm x 76.2mm)
Field of View Accuracy	Within .010mm
Optical Magnification	.090X
Total Magnification on Monitor	3X
Working Distance	255mm
Camera	5MP 2/3" CCD Monochromatic
Lighting	LED
Software	MetLogix M3 on Windows® operating system
Net Weight of HVR	100 lbs (45.5 kg)
Shipping weight - all components crated	206 lbs
Shipping crate dimensions	48" x 26" x 31" (122cm x 66cm x 78cm)



VERTICAL

FLIP

HORIZONTAL



FEATURES

- Rapidly measure parts up to 3.65 x 3"
- Working distance of 10"
- Measure a single feature, an entire part, or multiple parts
- MetLogix™ M3 software allows for easy one-touch feature measurement
- Auto-detect part recognition
- DXF Import - Electronic overlay for quick part comparison
- Export features to DXF
- Compare complex profiles with discreet data points and comparison to CAD
- Graphic based "Part View" constructions
- Geometric tolerancing
- Flexible report content and formatting
- Multi-language support
- Optional software modules:
 - Profile fitting
 - Wire insulation
 - Thread measurement
- System can be easily converted from a vertical format to a horizontal format measuring system

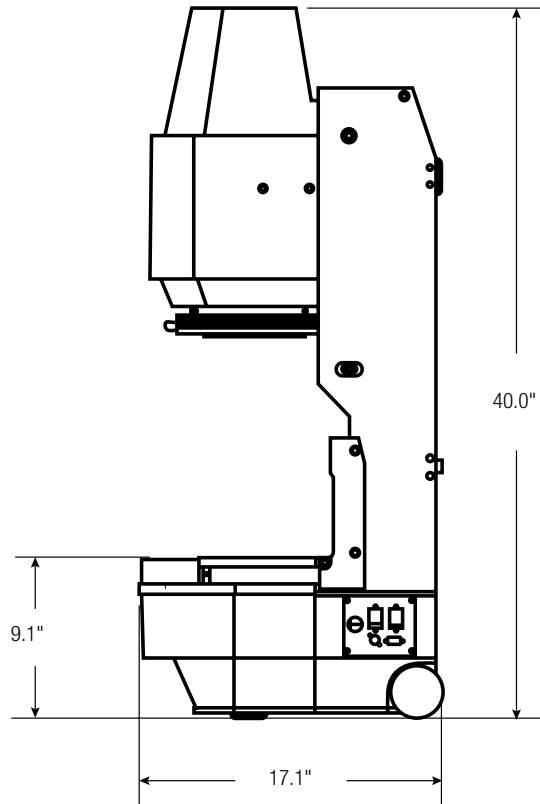
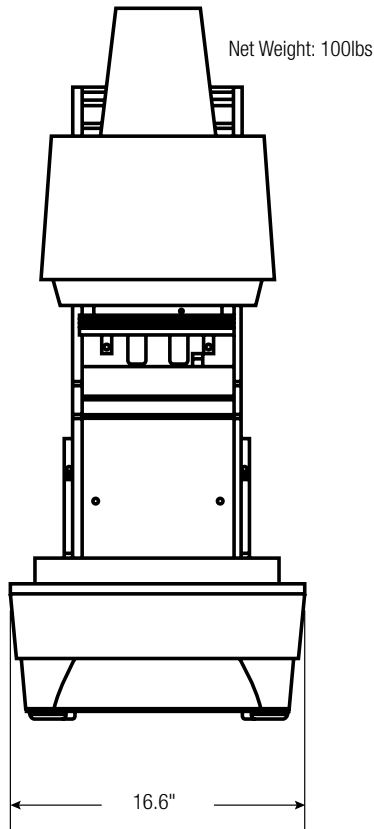

MetLogix™ M3 Software includes 24" touch-screen monitor and Windows® 10 operating system.

OPERATOR INTERFACE

Feature	MetLogix™ M3 DXF/FOV
PC installed in main housing	x
24" color graphics touch screen	x
Windows®-based operating system	x
X-Y-Q (angle) measurements	x
2D geometry software with skew	x
Video edge detection	x
CAD file import and export	x
FOV measurements	x
Elimination of overlays	x
64-bit Intel® processor	x
Software developer	MetLogix™



HORIZONTAL DIGITAL VIDEO COMPARATORS

HDV

HDV300 AND HDV400

HDV300 CNC, HDV400 CNC AND HDV500 CNC

The HDV Horizontal Digital Video Comparators combine the best features of a horizontal optical comparator and a vision metrology system. The HDV is configured like a traditional horizontal comparator. The workstage is the same as the Starrett field-proven comparators. The heart of the HDV system centers on a uniquely designed interchangeable lens mounting system coupled to a hi-resolution 5 mega-pixel digital video camera. The system is available with a choice of seven telecentric lenses for micron-level resolution and optical distortion as low as 0.001% for accurate field-of-view (FOV) measurements. With MetLogix™ M3 software DXF CAD files can be imported and 2D Go/No-Go digital overlays can be developed directly from the CAD files. Video edge detection (VED) allows real-time interaction of the imported file with the video image of the part being inspected. Productivity, speed and accuracy are all enhanced. Systems are available in manual or CNC control.

HDV300/400 OPTICS

System Parameter	Telecentric Lenses							6.5:1 Zoom Lens	
	0.14x	0.30x	0.50x	0.80x	1.0x	2.0x	4.0x	0.7x	4.5x
Optical magnification	0.14x	0.30x	0.50x	0.80x	1.0x	2.0x	4.0x	0.7x	4.5x
Magnification on 24" monitor	8.6x	18.5x	21x	49x	62x	124x	247x	58x	363x
Field of view width	2.36" (63mm)	1.14" (29mm)	.59" (15mm)	.43" (11mm)	.35" (9mm)	.18" (4.3mm)	.09" (2.3mm)	.4" (11mm)	.05" (1.5mm)
Field of view height	2.0" (51mm)	0.94" (24mm)	0.56" (14mm)	0.35" (8.9mm)	0.28" (7.1mm)	0.14" (3.7mm)	0.07" (1.8mm)	0.40" (10.1mm)	0.62" (15.6mm)
Working distance	4.3" (110mm)	4.3" (110mm)	4.3" (110mm)	4.3" (110mm)	4.3" (110mm)	4.3" (110mm)	4.3" (110mm)	3.4" (88mm)	3.4" (88mm)
Optical Distortion, %	0.001	0.001	0.002	0.002	0.005	0.005	0.006	N/A	N/A

OPERATOR INTERFACE

Feature	MetLogix™ M3 DXF/FOV
PC installed in main housing	x
24" color graphics touch screen	x
Windows®-based operating system	x
X-Y-Q (angle) measurements	x
2D geometry software with skew	x
Video edge detection	x
CAD file import and export	x
FOV measurements	x
Elimination of overlays	x
64-bit Intel® processor	x
Software developer	MetLogix™





FEATURES AND SPECIFICATIONS

- Steel and aluminum construction with hard anodized stage tooling plate
- 21.3 x 5.1" (540 x 130mm) workstage
- 110lbs (50kg) maximum load capacity
- 2" (51mm) of focus travel
- Manual X-Y and focus positioning via hand wheels or CNC with joystick and trackball positioning
- Heidenhain glass scales for 0.5µm (.00002") X and Y resolution
- LED illumination for surface and profile lighting
- 5 mega-pixel color video camera (2448 x 2058 pixels)
- Software and part image displayed on 24" (60cm) touch-screen color monitor (1920 x 1080 pixels)

OPTIONS

- 6 interchangeable telecentric lenses for fields of view from 1.14 to 0.09 (29 to 2.3mm) (patent US 9,360,435 B2)
- Interchangeable 6.5:1 zoom optics
- Systems are also available with fixed .14x lens offering 2.5 x 1.9" (63 x 47mm) FOV. (Lenses are not interchangeable on this model)
- MetLogix™ M3 software with DXF/FOV, Profile fitting and Thread Measurement Modules
- Optional CNC controls
- 23" or 32" purpose built cabinet stands
- Extensive line of calibration standards, work-holding devices and accessories

HDV300 / HDV400 DIMENSIONS

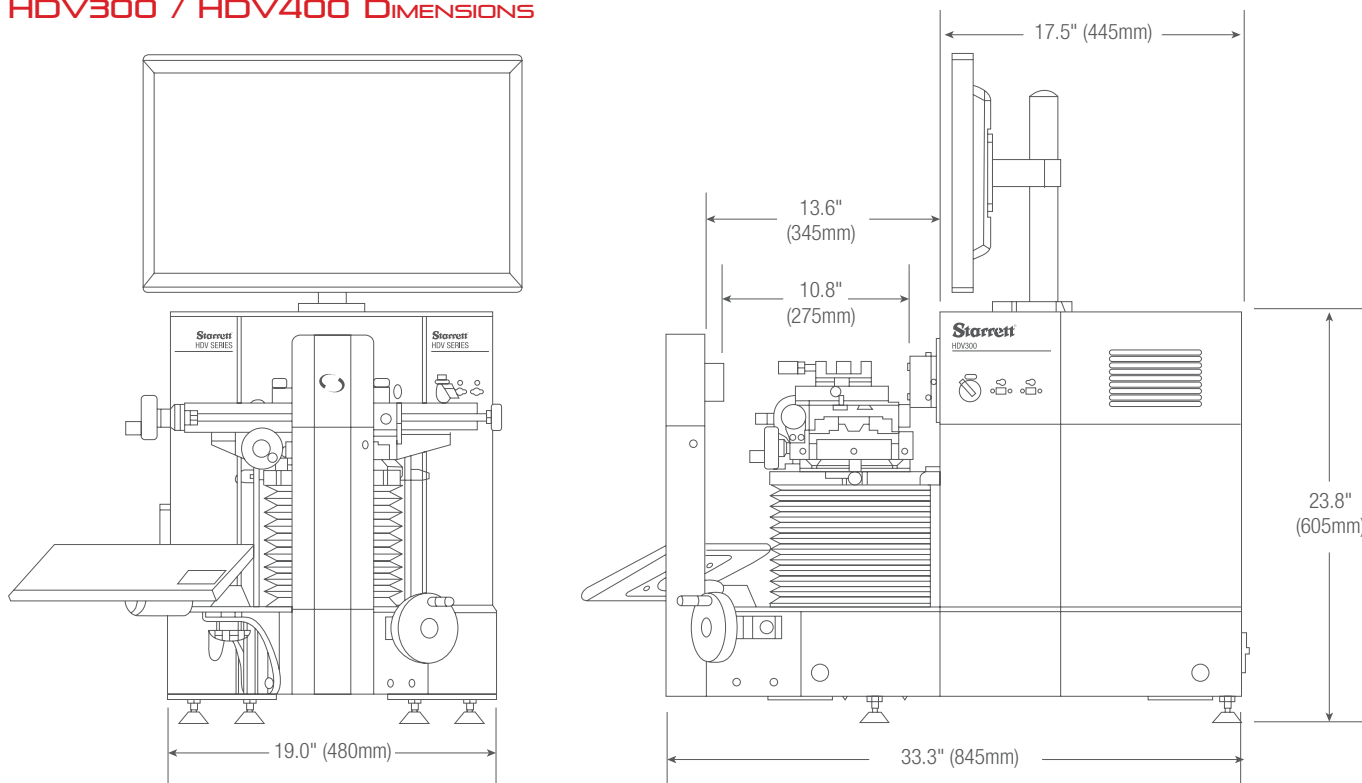

SPECIFICATIONS

	HDV300	HDV400
Net Weight	220lbs 100kg	230lbs 105kg
Shipping Weight	430lbs 195kg	440lbs 200kg
X-Y Travel	12 x 6" 300 x 150mm	16 x 6" 400 x 150mm
X-Y Accuracy	E2 = 3.0 µm + L/33	E2 = 3.0 µm + L/33



HORIZONTAL DIGITAL VIDEO COMPARATORS

HDV

HDV500 CNC

The HDV500 CNC Digital Video Comparator offers the best features of a large, floor standing, horizontal optical comparator and a vision metrology system. The HDV500 has a long 20 x 8" X-Y stage and heavy-duty steel construction. The workstage is the same as the popular HF600 and HF750. The heart of the HDV system centers on a uniquely designed interchangeable lens mounting system (patent pending) to a hi-resolution 5 mega-pixel digital video camera. The HDV500 is available with zoom optics or a choice of three telecentric lens options for micron-level resolution and for accurate Field-of-View (FOV) measurements.

With MetLogix™ M3 Metrology software, DXF CAD files can be imported and 2D Go-No-Go digital overlays can be developed directly from the CAD files. Video edge detection (VED) allows real-time interaction of the imported file with the video image of the part being inspected. Productivity speed and accuracy are all enhanced.

HDV500 OPTICS

System Parameter	Telecentric Lenses			6.5:1 Zoom Lens	
Optical magnification	0.11x	0.16x	0.24x	0.7x	4.5x
Magnification on 42" monitor**	6.5x	9.3x	14.7x	41x*	262x*
Field of view width	3.0" (76mm)	2.1" (54mm)	1.4" (35mm)	47" (12mm)	.40" (10mm)
Field of view height	2.5" (64mm)	1.8" (45mm)	1.1 (29mm)	.46" (11.7mm)	.072" (1.8mm)
Working distance	9.0" (228mm)	6.25"(159mm)	6.0" (150mm)	140mm	140mm
Optical Distortion, %	0.02%	0.03%	0.04%	—	—

*Best fit software setting

**Note that screen magnification is variable based on setting in M3 software

OPERATOR INTERFACE

Feature	MetLogix™ M3 DXF/FOV
PC installed in main housing	x
42" (1070cm) color monitor	x
Windows®-based operating system (1080 pixels)	x
X-Y-Q (angle) measurements	x
2D geometry software with skew	x
Video edge detection	x
CAD file import and export	x
FOV measurements	x
Elimination of overlays	x
64-bit Intel® processor	x
Software developer	MetLogix™



FEATURES AND SPECIFICATIONS

- Steel construction with nickel plated stage tooling plate
- 21.3 x 5.1" (540 x 130mm) workstage top plate
- CNC controls
- 330lb (150kg) maximum load capacity
- 3" (75mm) of focus travel
- Helix angle adjustment with $\pm 15^\circ$ Vernier scale
- X-Y and focus positioning via joystick and trackball positioning
- Heidenhain glass scales for 0.5 μ m (.00002") X and Y resolution
- LED illumination for surface and profile lighting
- 5 mega-pixel black and white digital video camera (2448 x 2058 pixels)
- Floor standing model

OPTIONS

- 6.5:1 zoom optics interchangeable
- 3 interchangeable telecentric lenses for fields of view including - 1.4 x 1.1", 2.1 x 1.8" and 3.0 x 2.5" (patent pending)
- MetLogix™ Profile Fitting and Thread Measurement software
- Extensive line of accessories, workholding devices and calibration standards
- APT60 or 200, rotary indexing table

HDV500 DIMENSIONS

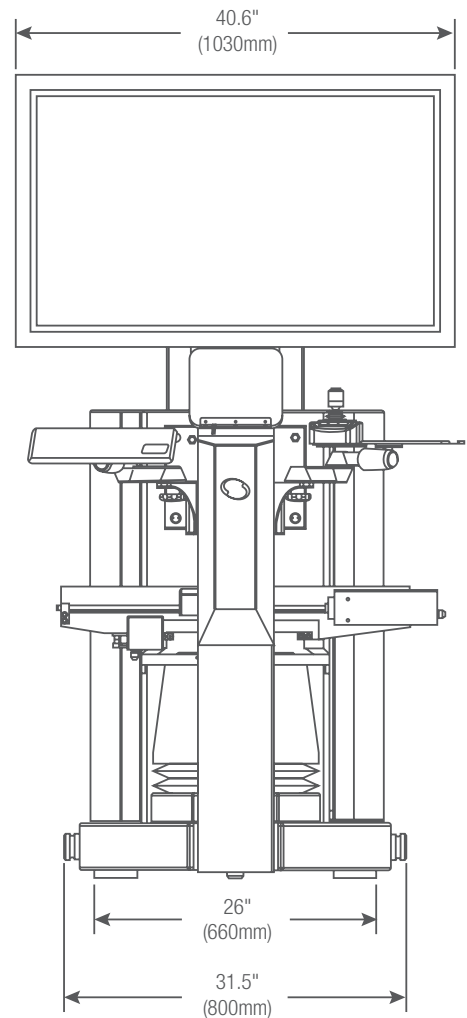
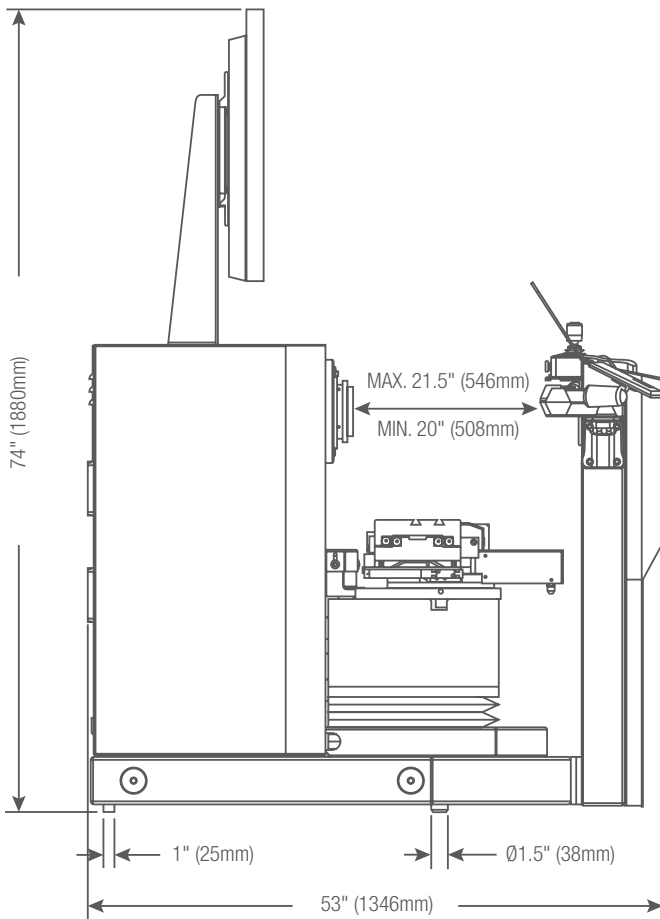

SPECIFICATIONS

	HDV500
Net Weight	1330lbs 600kg
Shipping Weight	1400lbs 635kg
X-Y Travel	20 x 8" 500 x 200mm
X-Y Accuracy	E2 = 3.0 μ m + L/33

SPECIFICATIONS AND OPTIONS

Model	MVR200	MVR300	AV300	AV350 / AV450	AVR200
Bench-Top System	X	X	X	–	X
Floor-Standing System	–	–	–	X	–
Part View Orientation	Vertical	Vertical	Vertical	Vertical	Vertical
X-Y-Z Travel (in)	8 x 4 x 8"	12 x 8 x 8"	12 x 6 x 5.5"	14 x 14 x 8"(AV350+) 18 x 14 x 8" (AV450+)	8 x 4 x 8"
X-Y-Z Travel (mm)	200 x 100 x 200mm	300 x 200 x 200mm	300 x 150 x 135mm	350 x 350 x 200mm (AV350+) 450 x 350 x 200mm (AV450+)	200 x 100 x 200mm
Z Axis Measuring	Optional	Optional	Standard	Standard	Standard
CNC	–	–	Standard	Standard	Standard
X-Y Accuracy (µm)	E2 = 2.5µm + 5L/1000	E2 = 2.5µm + 5L/1000	E2 = 1.9µm + 5L/1000	E2 = 2.5µm + 5L/1000	E2 = 1.9µm + 5L/1000
Z Accuracy (µm)	E1 = 2.5µm + 5L/1000	E1 = 2.5µm + 5L/1000	E1 = 2.5µm + 5L/1000	E1 = 2.5µm + 5L/1000	E1 = 2.5µm + 5L/1000
Scale Resolution	0.5µm	0.5µm	0.1µm	0.1µm	0.1µm
Multi-Sensor Compatible	–	–	–	–	–
Base	Granite	Granite	Cast Aluminum	Granite	Granite
Control System/Software	M3	M3	M3 or QC5300	M3	M3
Display	24" Touchscreen PC	24" Touchscreen PC	24" Touchscreen PC (M3) or 24" Monitor	24" Touchscreen PC	24" Touchscreen PC
Zoom Optics - Standard	6.5:1	6.5:1	6.5:1	12:1	6.5:1 - 2 LED 12:1 - 3 LED
Zoom Optics - Optional	–	–	–	–	–
Telecentric Optics	–	–	–	–	–
Digital Video Camera	1.3 or 2.0 MP Color with Telecentric	1.3 or 2.0 MP Color with Telecentric	1.3 MP Color	1.3 MP Color	1.3 MP Color Standard; 2 MP with Telecentric
Surface Ring Illumination	LED	LED	LED or Fiber Optic	LED or Fiber Optic	LED
Transmitted Illumination	LED	LED	LED or Fiber Optic	LED or Fiber Optic	LED
Coaxial Illumination - Optional	LED	LED	LED or Fiber Optic	LED or Fiber Optic	LED
Auxiliary Lenses - Optional	0.5x, 1.5x, 2.0x	0.5x, 1.5x, 2.0x	0.5x, 1.5x, 2.0x	0.5x, 1.5x, 2.0x	0.5x, 1.5x, 2.0x
Rotary Fixture	–	–	Optional	Optional	Optional
Renishaw Touch Probe	–	–	Optional	Optional	Optional
Renishaw Touch Probe Change Rack	–	–	Optional	–	–
Touch Probe Spotter Camera	–	–	–	–	–
Optimet Laser	–	–	–	–	–
Machine Pedestal and Point of Control Cart/Arm	–	–	–	Standard	–
Cabinet Stand	–	–	–	–	–
Workstation Base, Extension and Swing Arm	Optional	Optional	Optional	–	Optional
Part Fixturing	Optional	Optional	Optional	Optional	Optional
Dark Field Quadrant Illumination (LED only)	–	–	Optional	Optional	Optional
Video Pixel Calibration Standard	Optional	Optional	Optional	Optional	Optional
Calibration Standards	Optional	Optional	Optional	Optional	Optional
FOV, Linear and 2D Calibration Standards	Optional	Optional	Optional	Optional	Optional

AVR300	AV300+	AV350+ / AV450+	LF and LFM	HDV300	HDV400	HDV500
X	–	–	–	X	X	–
–	X	X	Standard	–	–	X
Vertical	Vertical	Vertical	Vertical	Horizontal	Horizontal	Horizontal
12 x 8 x 8"	12 x 6 x 8"	14 x 14 x 8" (AV350+) 18 x 14 x 8" (AV450+)	18 x 12 x 8" 28 x 24 x 8" 38 x 30 x 8" Special Quote 50 x 36 x 8" Special Quote	12 x 6"	16 x 6"	20 x 8"
300 x 200 x 200mm	300 x 150 x 200mm	350 x 350 x 200mm (AV350+) 450 x 350 x 200mm (AV450+)	460 x 305 x 200mm 711 x 610 x 200mm 965 x 760 x 200mm Special Quote 1270 x 915 x 200mm Special Quote	300 x 150mm	400 x 150mm	500 x 200mm
Standard	Standard	Standard	Standard	–	–	–
Standard	Standard	Standard	Standard	Optional	Optional	Standard
E2 = 1.9µm + 5L/1000	E2 = 1.9µm + 5L/1000	E2 = 2.5µm + 5L/1000	E2 = 2.5 + 5L/1000 on LF and 3.5 + 5L/1000 on LFM	E1 = 3.0µm + L33	E1 = 3.0µm + L/33	E1 = 3.0µm + L/33
E1 = 2.5µm + 5L/1000	E1 = 2.5µm + 5L/1000	E1 = 2.5µm + 5L/1000	E1 = 2.5 + 5L/1000	–	–	–
0.1µm	0.1µm	0.1µm	0.1µm	0.5µm	0.5µm	0.5µm
–	Yes	Yes	X	–	–	–
Granite	Granite	Granite	Granite	Steel	Steel	Steel
M3	QC5300	QC5300	QC5300 or M3	M3	M3	M3
24" Monitor	24" Monitor	24" Monitor	24" Monitor	24" Touch Screen	24" Touch Screen	42" Monitor
6.5:1 - 2 LED 12:1 - 3 LED	12:1	12:1	12:1	–	–	–
–	–	–	6.5:1	6.5:1	6.5:1	-
–	–	–	–	Choice of 4.0x, 2.0x, 1.0x, 0.80x, 0.50x and 0.30x interchangeable Telecentric Lenses Optional- 0.14x fixed	Choice of 4.0x, 2.0x, 1.0x, 0.80x, 0.50x and 0.30x interchangeable Telecentric Lenses Optional- 0.14x fixed	Choice of 0.24x, 0.16x and 0.11x interchangeable Telecentric Lenses
1.3 MP Color Standard; 2 MP with Telecentric	1.3 MP Color	1.3 MP Color	1.3 MP Color	5 MP Color	5 MP Color	5 MP Black and White
LED or Fiber Optic	LED or Fiber Optic	LED or Fiber Optic	LED	LED	LED	LED
LED or Fiber Optic	LED or Fiber Optic	LED or Fiber Optic	LED	LED	LED	LED
LED or Fiber Optic	LED or Fiber Optic	LED or Fiber Optic	LED	–	–	–
0.5x, 1.5x, 2.0x	0.5x, 1.5x, 2.0x	0.5x, 1.5x, 2.0x	0.5x, 1.5x, 2.0x	–	–	–
Optional	Optional	Optional	Optional	–	–	–
Optional	Optional	Optional	Optional	–	–	–
–	Optional	Optional	Optional	–	–	–
–	–	–	Optional	–	–	–
–	Optional	Optional	Optional	–	–	–
–	Standard	Standard	Standard	–	–	–
–	–	–	–	Optional	Optional	–
Optional	–	–	–	–	–	–
Optional	Optional	Optional	Optional	Optional	Optional	Optional
Optional	Optional	Optional	Optional	–	–	–
Optional	Standard	Standard	Standard	Optional	Optional	Optional
Optional	Optional	Optional	Optional	Optional	Optional	Optional
Optional	Optional	Optional	Optional	Optional	Optional	Optional

ACCESSORIES



Fiber-optic and LED Illumination



Rotary part positioner with collet kit



Modular system work stands



Part Holding Fixtures



Touch Probe Kits



NIST Traceable Calibration Standards

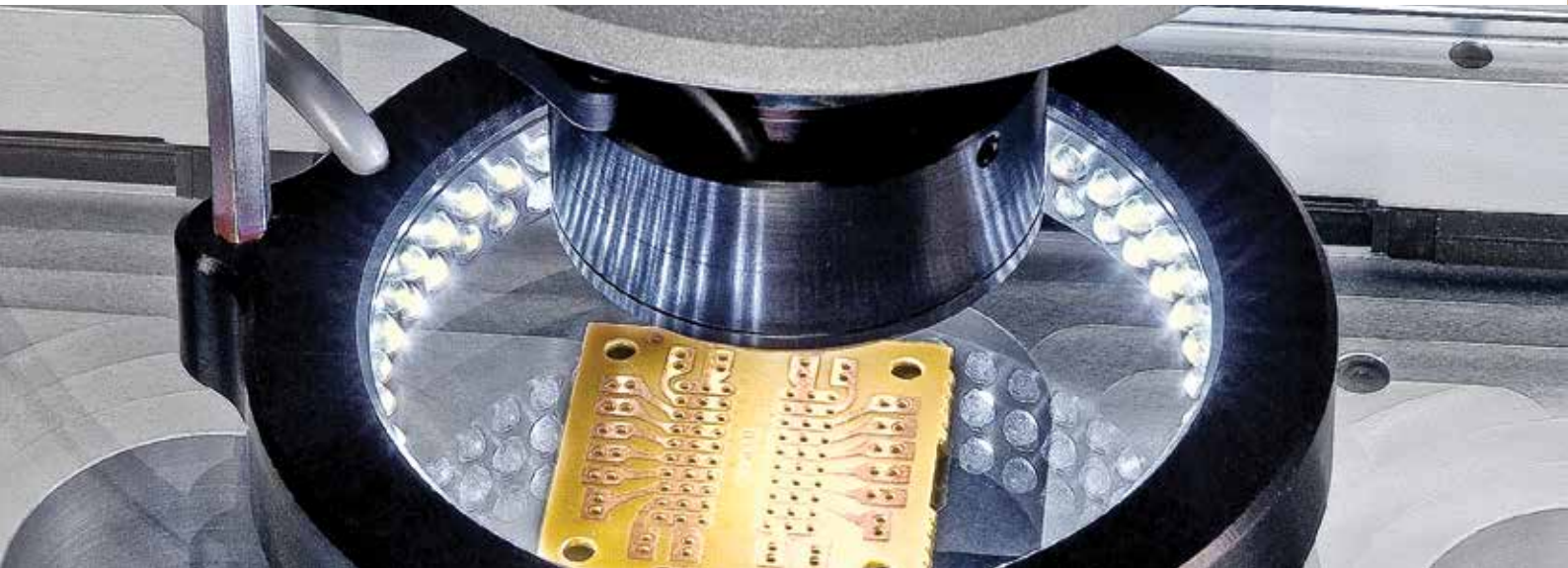

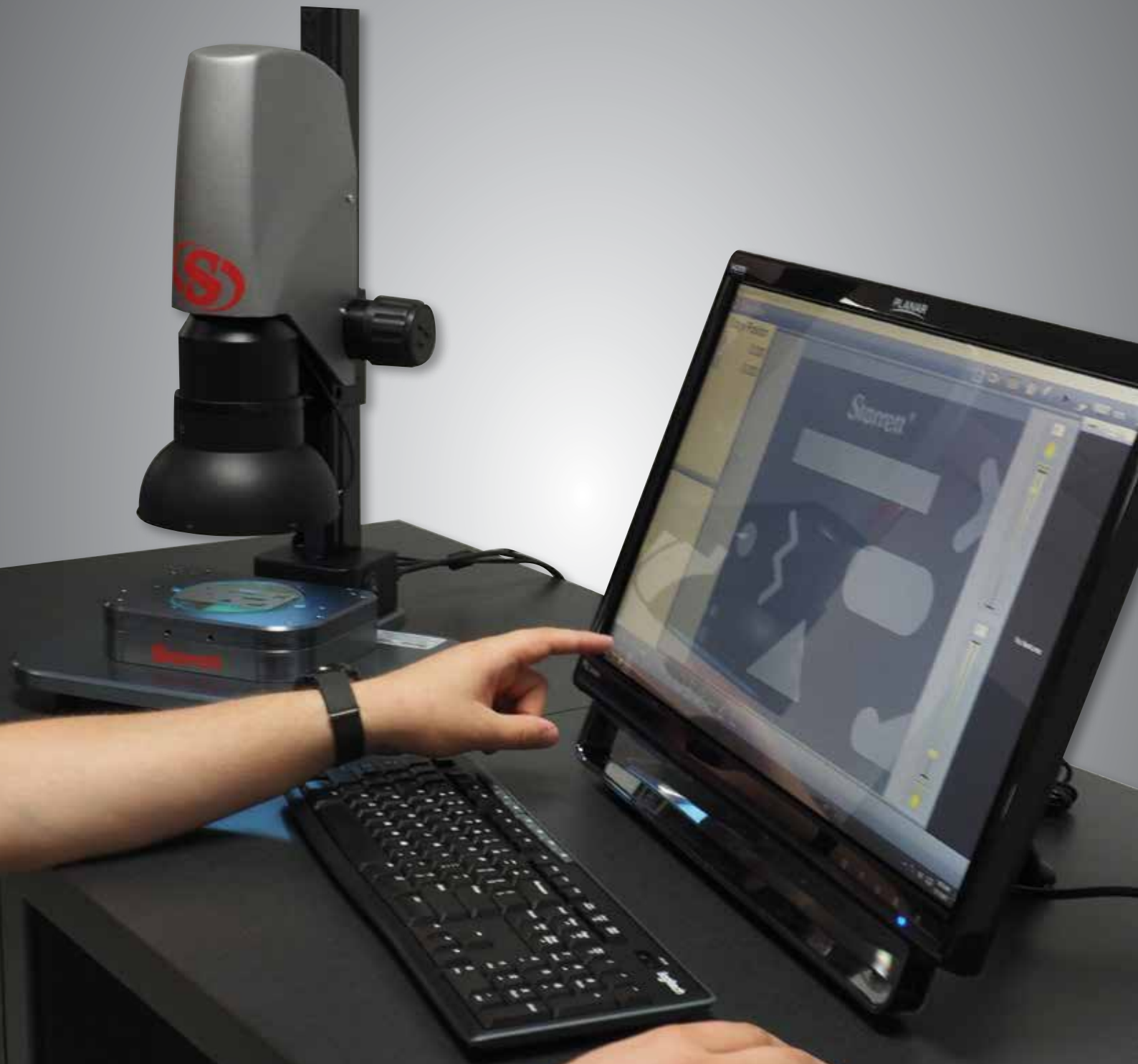

VIDEO INSPECTION SYSTEMS

VIDEO INSPECTION SYSTEMS

KineMic™

KMR

KineMic™ video microscopes are a family of seven versatile and affordable inspection and vision metrology systems. They are ideal for receiving inspection, quality assurance, training, manufacturing, assembly, research, and documentation – wherever easy setup and a range of magnifications are required. Depending on the size of the parts to be measured, measurements can be all electronic within the field of view, or be integrated with stage motion for parts up to 8" (200mm).

FEATURES

- XGA models set the standard for quick setup and ease of use by not requiring a computer
- D1 and M3 models offer the power of a 24" color touch-screen monitor and PC with MetLogix™ inspection and metrology software
- LED surface and transmitted illumination
- Small footprint takes up minimal space



KMR-200 with M3



KMR-FOV-M3-0.14x

Our KMR systems line provide high performance for low cost. These machines are simple to operate without compromising performance.

With seven models to choose from, we can customize to your specific needs.

Call (949) 348-1213 for an exact quote.

	KineMic XGA Zoom, Basic	KineMic XGA Zoom, 2 x 2 Stage	KineMic D1 Zoom	KineMic D1 Zoom, 2 x 2 Stage	KineMic M3 Zoom, FOV	KineMic M3 Telecentric, FOV	KineMic M3 Zoom, 4 x 8 Stage
Part Number	KMR-XGA	KMR-50-XGA	KMR-D1	KMR-50-D1	KMR-Zoom-M3	KMR-FOV-M3	KMR-200-M3
Optics	6.5:1 zoom	6.5:1 zoom	6.5:1 zoom	6.5:1 zoom	6.5:1 zoom	7 telecentric lenses	6.5:1 zoom
CCD Sensor	0.83 MPixel	0.83 MPixel	1.33 MPixel	1.33 MPixel	1.33 MPixel	2.02 MPixel	1.33 MPixel
Camera Interface	VGA cable	VGA cable	USB cable	USB cable	USB cable	USB cable	USB cable
Computer	N/A	N/A	PC	PC	PC	PC	PC
Software	N/A	N/A	MetLogix™ D1	MetLogix™ D1	MetLogix™ M3	MetLogix™ M3	MetLogix™ M3
Video Screen	19" XGA monitor	19" XGA monitor	24" touch-screen monitor with PC	24" touch-screen monitor with PC	24" touch-screen monitor with PC	24" touch-screen monitor with PC	24" touch-screen monitor with PC
Screen Resolution	1024 x 768	1024 x 768	1920 x 1080	1920 x 1080	1920 x 1080	1920 x 1080	1920 x 1080
Lens Magnification	0.7x to 4.5x zoom	0.7x to 4.5x zoom	0.7x to 4.5x zoom	0.7x to 4.5x zoom	0.7x to 4.5x zoom	Telecentric Lenses: Choice of 0.14x, 0.3x, 0.5x, 0.8x, 1.0x and 4.0x magnifications	0.7x to 4.5x zoom
Screen Magnification	31x to 200x	31x to 200x	31x to 200x	31x to 200x	31x to 200x	13x to 178x	31x to 200x
Auxiliary lenses	0.5x, 0.75x, 1.5x, 2x	0.5x, 0.75x, 1.5x, 2x	0.5x, 0.75x, 1.5x, 2x	0.5x, 0.75x, 1.5x, 2x	0.5x, 0.75x, 1.5x, 2x	N/A	0.5x, 0.75x, 1.5x, 2x
Field of view (X-axis)	1.4 to 9.0mm	1.4 to 9.0mm	1.4 to 9.0mm	1.4 to 9.0mm	1.4 to 9.0mm	1.8 to 24mm	1.4 to 9.0mm
X-Y Stage Motion	None	50 x 50 mm	None	50 x 50 mm	None	None	200 x 100 mm
Metrology Means	None	Micrometers	D1 software**	D1 software**	M3 FOV software	M3 FOV software	X and Y encoders
Measurement Resolution	N/A	1µm (.00005")	Up to 2µm*	1µm (.00005")	Up to 2µm*	Up to 2µm*	0.5µm (0.00002")
Meas. Accuracy	N/A	3µm per 25mm	Up to ±2.5µm*	3µm per 25mm	Up to ±2.5µm*	Up to ±2.5µm*	2.5µm + 5L/1000
Basic Stand	Standard	Standard	Standard	Standard	Standard	Standard	Standard
Boom Stand	Optional	N/A	Optional	N/A	Optional	N/A	N/A
LED Back Light	Standard	Standard	Standard	Standard	Standard	Standard	Standard
LED Ring Light	Standard	Standard	Standard	Standard	Standard	Standard	Standard
Lighting Control	Adjustment knobs	Adjustment knobs	Adjustment knobs	Adjustment knobs	Via M3 software	Via M3 software	Via M3 software

* These are best values. Actual values will depend on the zoom lens setting or selected telecentric lens.

**D1 software basic measurements are taken by manually positioning a cross-hair on the screen.

Disclaimer: Due to continual product improvements, specifications may change without notice.

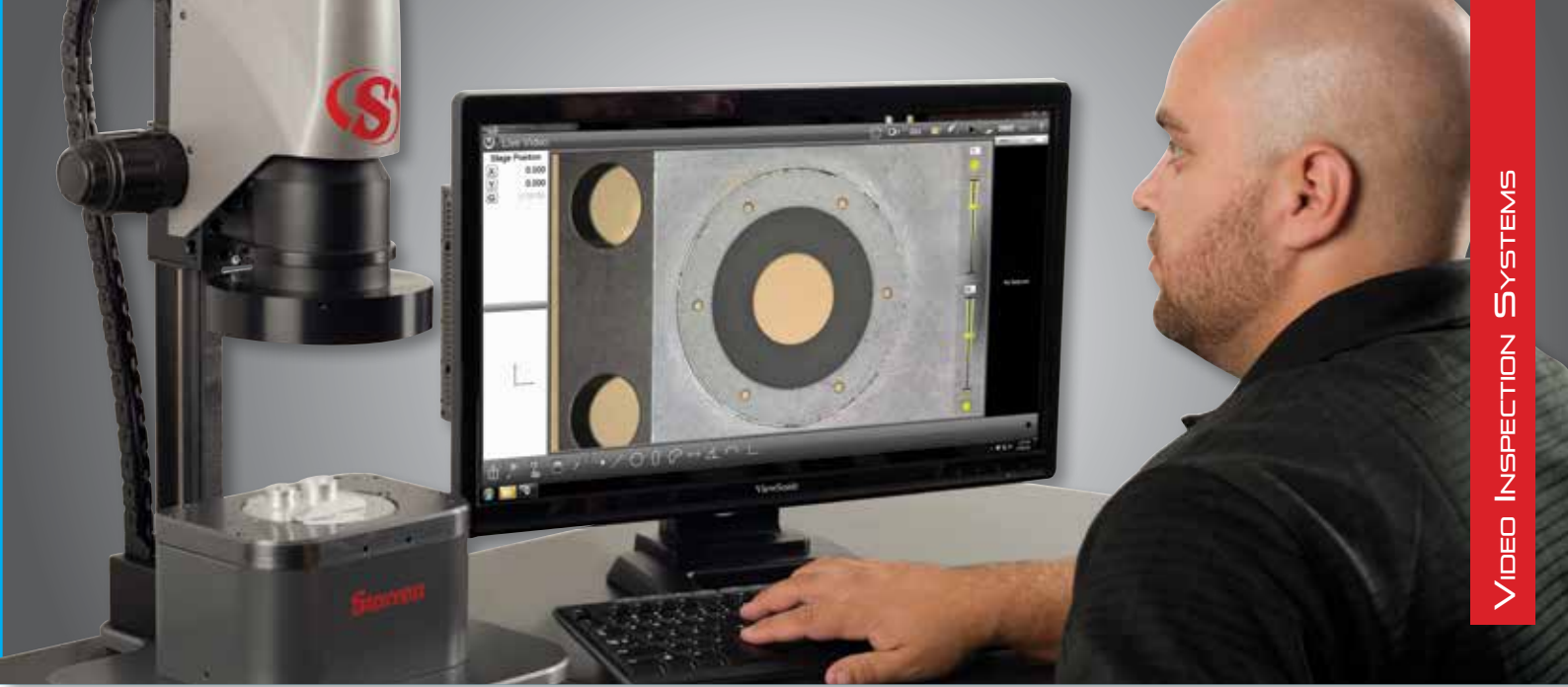

KMR 50-D1



KMR-XGA



KMR-D1



KMR-FOV with M3



	KineMic XGA Zoom, Basic	KineMic XGA Zoom, 2 x 2 Stage	KineMic D1 Zoom	KineMic D1 Zoom, 2 x 2 Stage	KineMic M3 Zoom, FOV	KineMic M3 Telecentric, FOV	KineMic M3 Zoom, 4 x 8 Stage
Model Number	KMR-XGA	KMR-50-XGA	KMR-D1	KMR-50-D1	KMR-Zoom-M3	KMR-FOV-M3	KMR-200-M3
Video Inspection	Yes	Yes	Yes	Yes	Yes	Yes	Yes
Basic Dimensions	No	Manual LCD Micrometer	Yes - Manual	Manual LCD Micrometer	VED - FOV measurement	VED - FOV measurement	VED - FOV measurement
Geometric Constructs	No	No	No	No	Yes	Yes	Yes
Image Annotation	No	No	Yes	Yes	Yes	Yes	Yes
Image Archiving	No	No	Yes	Yes	Yes	Yes	Yes
Video Edge Detection	No	No	No	No	Yes	Yes	Yes



690

PRECISION MAKES THE DIFFERENCE

EXCEED YOUR CAPABILITIES.

The Starrett® FMS Series incorporates new performance-based capabilities and user-friendly features to help you perform critical force tests with greater accuracy and efficiency.

It can perform all of your basic force measurement tests, as well as more complex multi-stage tests to international standards.



Model FMS5000

Starrett®

(978) 249-3551 • starrett.com

Follow us!





OPTICAL COMPARATORS

HORIZONTAL BENCH-TOP OPTICAL COMPARATOR

HE400

The most economical of our bench top comparators, the HE400 offers a 16" (400mm) diameter screen, X-Y stage travel, choice of six bayonet-style fixed interchangeable lenses and Q-axis angular readout: all to improve capability and performance. These latest horizontal comparators are fitted with either MetLogix™ M1 or M2 measuring software or Quadra-Chek® digital readout systems as standard, making them simple to use, but having the power to satisfy the most complex measuring requirements.

OPERATOR INTERFACE

Feature	MetLogix™		Quadra-Chek®	
	M1	M2	QC121	QC221
Mounted to comparator arm	x	x	x	x
Color graphics	x	x		
Touch screen operation	x	x		
MS Windows® operating system	x	x		
X-Y-Q axis digital readout	x	x	x	x
2D geometry software with skew	x	x	x	x
Optical edge detection option	x	x	x	x
Software developer	MetLogix™	MetLogix™	Metronics/Heidenhain	Metronics/Heidenhain



HE400

SPECIFICATIONS

HE400	
Horizontal Travel	10" (250mm)
Vertical Travel	4" (100mm)
Focus Travel	1-1/8" (28mm)
Top Plate*	18.75 x 4.7" (480 x 120mm)
Image	Inverted and reversed

*With machined single slot for easy fixturing



FEATURES AND SPECIFICATIONS

- All metal construction
- Single bayonet-style lens mounting system
- Collimating condenser with yellow/green filter and provision to mount further accessories
- Linear encoder (glass scale) with $.5\mu\text{m}$ on both X and Y axes
- LED profile and surface illumination
- Fully retractable flexible duplex fiber optic surface illumination
- Digital protractor for accurate angle measurement 1' resolution
- Available with MetLogix™ M1 tablet, M2 PC-based touch screen measuring software or Quadra-Chek® digital readout system
- 15.4lb (7kg) load capacity
- 18.75 x 4.74" (480 x 120mm) precision workstage top plate with machined slot for easy fixturing
- 10 x 4" (254 x 100mm) of XY stage travel
- 1-1/8" (8mm) focus travel
- Fine adjustment on all axes
- Quick release mechanism on the X-axis

OPTIONS

- Six interchangeable fixed magnification lenses including 10x, 20x, 25x, 31.25x, 50x and 100x
- Automatic fiber optic edge detection
- Canopy and curtains (designed to mount on Starrett cabinet stand)
- Purpose built cabinet stand
- Extensive line of accessories

HE400 DIMENSIONS

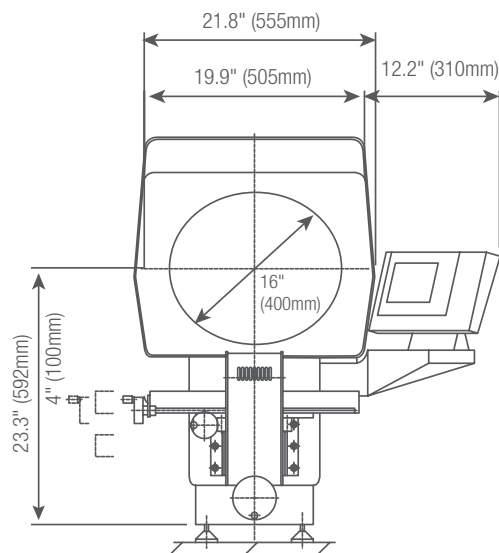
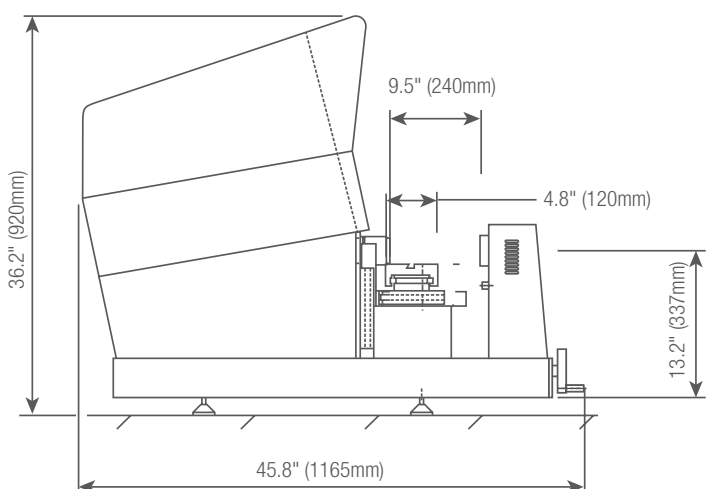

WEIGHT AND DIMENSIONS

	HE400
Net Weight	230lbs 105kg
Shipping Weight	300lbs 135kg
Shipping Dimensions	49" (L) x 32" (W) x 51" (H)

HORIZONTAL BENCH-TOP OPTICAL COMPARATOR

HB400

The HB400 Optical Comparator provides exceptional performance with a 16" (400mm) diameter viewing screen and 110lbs workstage load capacity. Available with optical and/or video edge detection which removes operator subjectivity in locating edges of parts being measured. A bayonet style lens mounting system accepts a choice of six fixed interchangeable lenses as well as the OV2 Zoom or TOV2 fixed telecentric magnification video camera systems. Motorized stage, fully automatic CNC controls and swing-away lamp house are all optional features. This comparator provides performance previously only available with floor standing models.

OPERATOR INTERFACE

Feature	MetLogix™			Quadra-Chek®		
	M1	M2	M3	QC121	QC221	QC5200
Mounted to comparator arm	x	x		x	x	
Color graphics	x	x	x			
Touch screen operation	x	x	x			
Operating system	Android	Windows	Windows			
X-Y-Q axis digital readout	x	x	x	x	x	x
2D geometry software with skew	x	x	x	x	x	x
Optical edge detection option	x	x	x	x	x	x
Video edge detection option			x			x
CAD file import and export option			x			x
CNC drive option		x	x		x	x
Software developer	MetLogix™	MetLogix™	MetLogix™	Metronics/Heidenhain	Metronics/Heidenhain	Metronics/Heidenhain



HB400

SPECIFICATIONS

HB400	
Horizontal Travel	12" (300mm)
Vertical Travel	6" (150mm)
Focus Travel	2" (50mm)
Top Plate*	21 x 5" (530 x 120mm)
Image	Erect and reversed

*With machined slots for easy fixturing



FEATURES AND SPECIFICATIONS

- All metal construction with hard-anodized stage tooling plate
- Single bayonet-style lens mounting system
- Collimating condenser with yellow/green filter and provision to mount further accessories
- Linear encoder (glass scale) on both X and Y axes
- LED profile and surface illumination
- Fixed duplex fiber optic surface illumination
- Digital protractor for accurate angle measurement (1' resolution) via Q-axis readout
- Available with MetLogix™ M1 tablet, M2 or M3 measuring software touch-screen and PC, or Quadra-Chek® digital readout system
- Fine adjustment on all axes
- Quick release mechanism on the X-axis

OPTIONS

- Six interchangeable fixed magnification lenses including 10x, 20x, 25x, 31.25x, 50x and 100x
- Optional 5x fixed or interchangeable lens system available by special order
- Optional extended travel workstage 16" (400mm)
- Automatic optical edge detection
- Automatic video edge detection (available only with OV2 or TOV2 video cameras)
- OV2 Video Camera with 6.5:1 zoom lens
- TOV2 Telecentric Video Camera with choice of 0.16x, 0.3x or 0.5x fixed magnification lens
- Motorized X and Y axes
- Fully automatic CNC controls
- Swing-away lamp house
- Canopy and curtains (designed to mount on Starrett cabinet stand)
- Purpose built cabinet stand
- Extensive line of accessories

HB400 DIMENSIONS

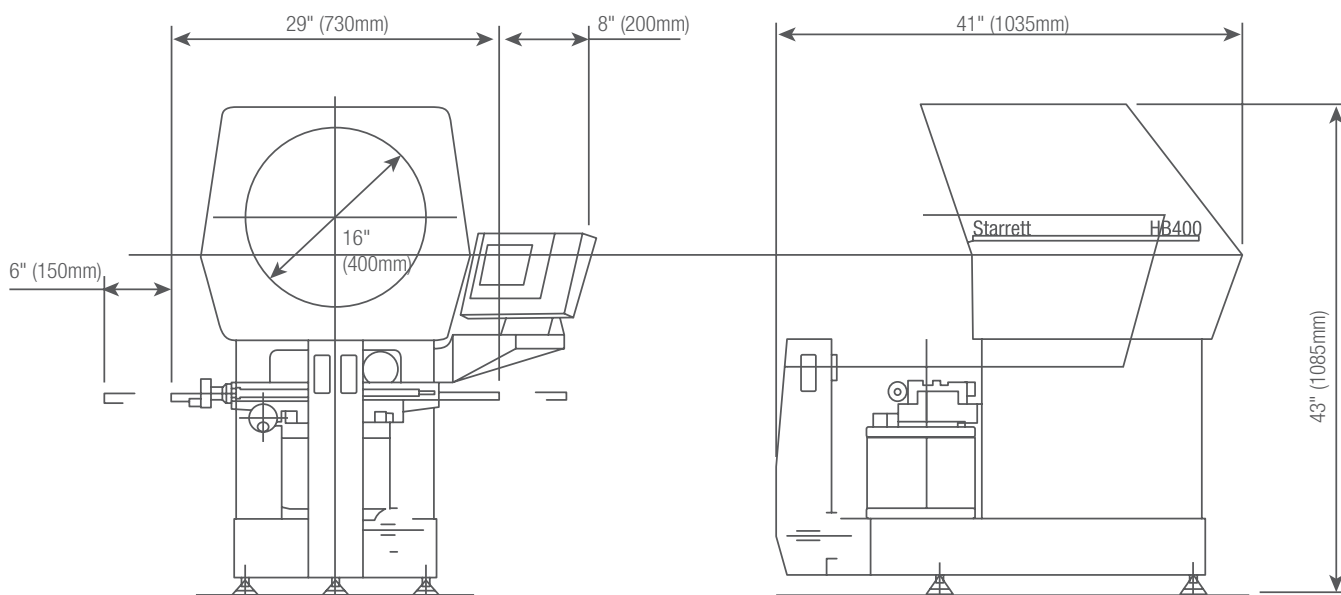

WEIGHT AND DIMENSIONS

	HB400
Net Weight	320lbs 145kg
Shipping Weight	385lbs 175kg
Shipping Dimensions	49" (L) x 32" (W) x 51" (H)

HORIZONTAL BENCH-TOP OPTICAL COMPARATOR

HD400

DUAL LENS

The HD400 is a dual lens optical comparator offering a two-lens mount allowing instant switching between two magnification lenses or video camera adaptor. The HD400 is equipped with a 16" (400mm) travel workstage as standard. Optional automatic edge detection or video edge detection removes operator subjectivity in locating edges of parts being measured. A bayonet style lens mounting system accepts a choice of six interchangeable lenses as well as our OV2 Zoom or TOV2 fixed telecentric magnification video camera systems. Motorized stage, fully automatic CNC controls and swing-away lamp house are all optional features.

OPERATOR INTERFACE

Feature	MetLogix™			Quadra-Chek®	
	M1	M2	M3	QC221	QC5200
Mounted to comparator arm	x	x		x	
Color graphics	x	x	x		
Touch screen operation	x	x	x		
Operating system	Android	Windows®	Windows®		
X-Y-Q axis digital readout	x	x	x	x	x
2D geometry software with skew	x	x	x	x	x
Optical edge detection option	x	x	x	x	x
Video edge detection option			x		x
CAD file import and export option			x		x
CNC drive option		x	x	x	x
Software developer	MetLogix™	MetLogix™	MetLogix™	Metronics/Heidenhain	Metronics/Heidenhain



HD400

SPECIFICATIONS

HD400	
Horizontal Travel	16" (400mm)
Vertical Travel	6" (150mm)
Focus Travel	2" (50mm)
Top Plate*	21 x 5" (530 x 120mm)
Image	Erect and reversed

*With machined slots for easy fixturing



FEATURES AND SPECIFICATIONS

- All metal construction with hard-anodized stage tooling plate
- 16" (400mm) diameter screen
- Dual-lens mounting system
- Collimating condenser with yellow/green filter and provision to mount further accessories
- Linear encoder (glass scale) on both X and Y axes
- LED profile and surface illumination
- Fully retractable flexible duplex fiber optic surface illumination
- Digital protractor for accurate angle measurements (1' resolution) via Q-axis readout
- Helix adjustment for accurate thread form inspection
- Available with MetLogix™ M1 tablet, M2 or M3 PC-based touch screen measuring software or Quadra-Chek® digital readout system
- Fine adjustment on all axes
- Quick release mechanism on the X-axis

OPTIONS

- Six interchangeable fixed magnification lenses including 10x, 20x, 25x, 31.25x, 50x and 100x
- Optional 5x fixed lens system available by special order
- Automatic optical edge detection
- Automatic video edge detection (available only with OV2 or TOV2 video cameras)
- OV2 Video Camera with 6.5:1 zoom lens
- TOV2 Telecentric Video Camera with choice of 0.16x, 0.3x, or 0.5x fixed magnification lens
- Motorized X and Y axes
- Fully automatic CNC controls
- Swing-away lamp house
- Canopy and curtains (designed to mount on Starrett cabinet stand)
- Purpose built cabinet stand
- Extensive line of accessories

HD400 DIMENSIONS

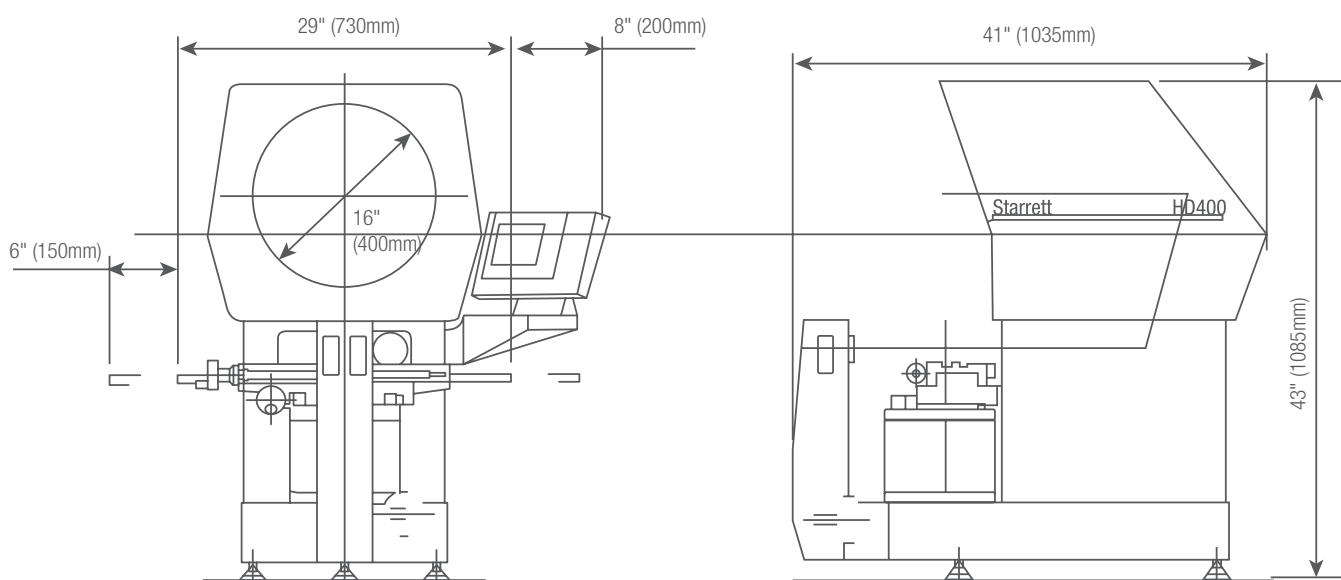

WEIGHT AND DIMENSIONS

	HD400
Net Weight	320lbs 145kg
Shipping Weight	385lbs 175kg
Shipping Dimensions	49" (L) x 32" (W) x 51" (H)

NEW! VERTICAL BENCH-TOP OPTICAL COMPARATOR

OPTICAL COMPARATORS

VB300

The VB300 is another optical comparator with the Starrett trademark formula: high performance at a low cost. This vertical bench top comparator is designed to meet the demands of modern industry and is ideal for the rapid inspection of small light-weight components, stampings, plastic molding, electronic components, small turned parts and more. The VB300 features a variety of digital displays making the VB300 easy to use and have the power to satisfy the most complex of measuring requirements.

OPERATOR INTERFACE

Feature	Integral LED readout	MetLogix™		Quadra-Chek®	
		M1	M2	QC121	QC221
Angular digital measurement in readout	x				
Mounted to comparator arm		x	x	x	x
Color graphics		x	x		
Touch screen operation		x	x		
Operating system		Android	Windows®		
X-Y-Q axis digital readout	x	x	x	x	x
2D geometry software with skew		x	x	x	x
Optical edge detection option		x	x	x	x
Software developer		MetLogix™	MetLogix™	Metronics/Heidenhain	Metronics/Heidenhain



SPECIFICATIONS

VB300	
Horizontal Travel	4" (100mm)
Vertical Travel	4" (100mm)
Focus Travel	3.5" (90mm)
Top Plate*	9 x 9" (225 x 225mm)
Glass Insert	6 x 6" (150 x 150mm)
Image	Reversed

*With machined slot for easy fixturing



FEATURES AND SPECIFICATIONS

- All metal construction for optimum performance
- 12" (300mm) diameter screen with overlay clips
- Linear encoder (glass scale) on both X and Y axes
- Stage weight capacity: 11lbs (5kg) (evenly distributed)
- LED profile and surface illumination
- Screen driven Q-axis
- Quick release mechanism on X-axis and Y-axis
- Available with a simple integrated LED readout display or choice of the new MetLogix™ M1 tablet, M2 PC-based measuring software, or Quadra-Chek® digital readout systems

OPTIONS

- Choice of four fixed magnification lenses including 10x, 20x, 25x and 50x
- Purpose built cabinet stand
- Workhold Accessories

VB300 DIMENSIONS

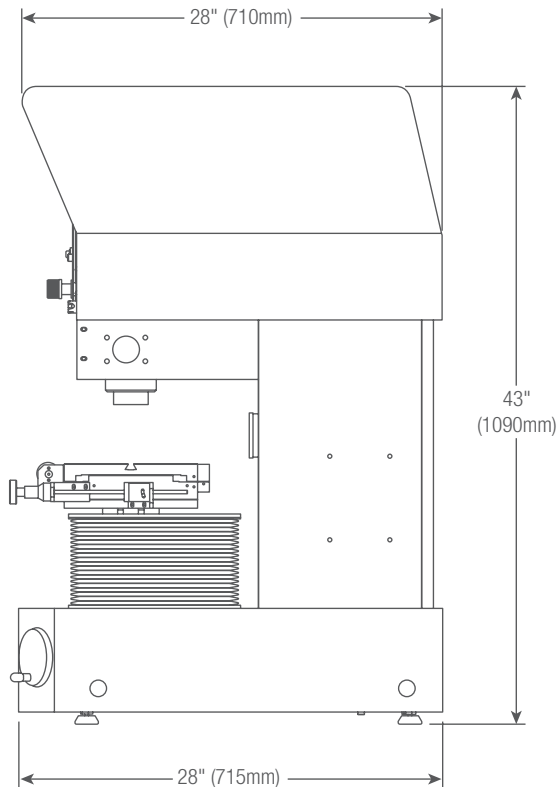
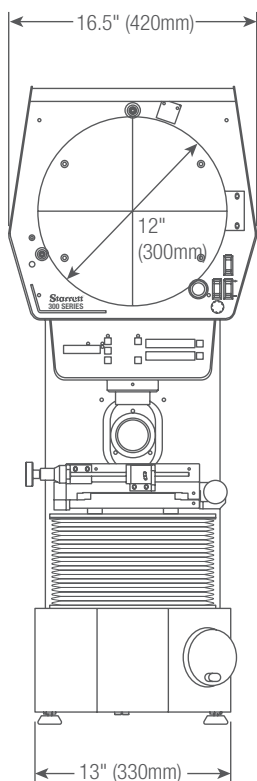

WEIGHT AND DIMENSIONS

	VB300
Net Weight	423lbs 192kg
Shipping Weight	443lbs 201kg
Gross Dimensions (L x W x H)	44 x 33 x 52"

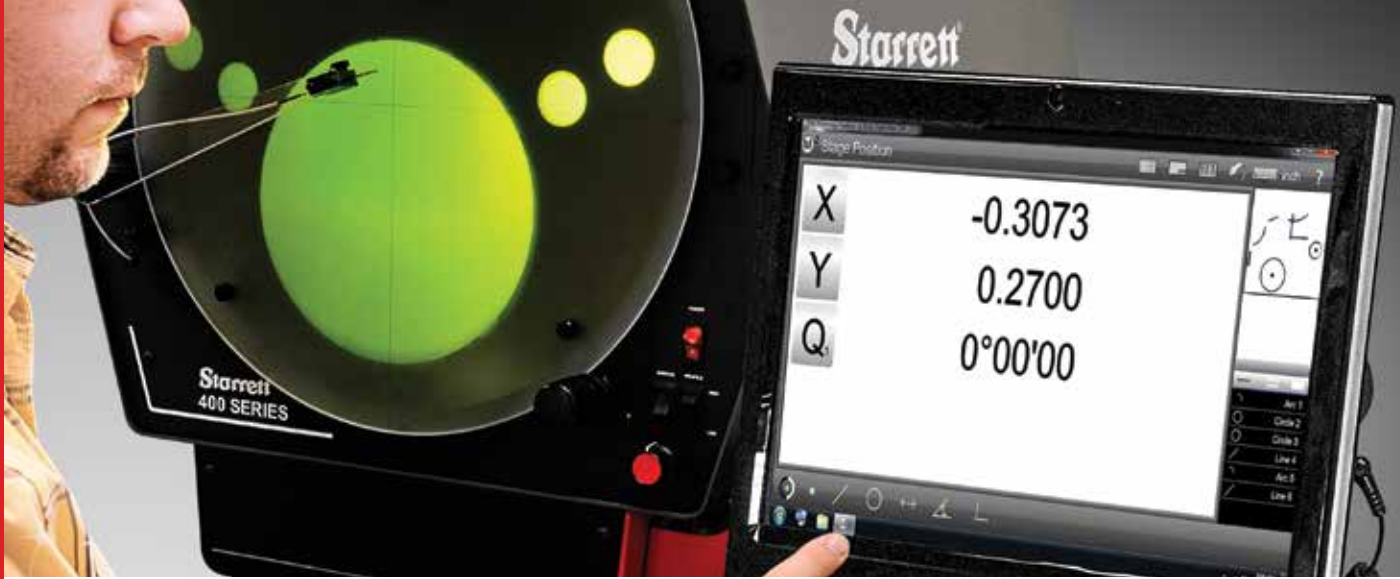

VERTICAL BENCH-TOP OPTICAL COMPARATOR

VB400

The VB400 Vertical Optical Comparator allows flat parts to be simply laid on a glass insert in the workstage. Features include a 16" (400mm) diameter vertical screen, ultra-bright LED profile and surface illumination, and linear encoder scales for 0.5µm resolution.

OPERATOR INTERFACE

Feature	MetLogix™		Quadra-Chek®	
	M1	M2	QC121	QC221
Mounted to comparator arm	x	x	x	x
Color graphics	x	x		
Touch screen operation	x	x		
Operating system	Anroid	Windows®		
X-Y-Q axis digital readout	x	x	x	x
2D geometry software with skew	x	x	x	x
Optical edge detection option	x	x	x	x
Software developer	MetLogix™	MetLogix™	Metronics/Heidenhain	Metronics/Heidenhain



VB400

SPECIFICATIONS

VB400

Horizontal Travel	8" (200mm)
Vertical Travel	4" (100mm)
Focus Travel	4" (100mm)
Top Plate*	16 x 9" (400 x 230mm)
Glass Insert	9-1/4 x 5-1/2" (235 x 140mm)
Image	Reversed

*With machined slot for easy fixturing

FEATURES AND SPECIFICATIONS

- All metal construction
- 16" (400mm) diameter screen
- Collimating condenser with yellow/green filter and provision to mount further accessories
- Linear encoder (glass scale) on both X and Y axes
- LED profile and surface illumination
- Digital protractor for accurate angle measurements (1' resolution) via Q-axis readout
- Available with MetLogix™ M1 tablet, M2 PC-based touch screen measuring software or Quadra-Chek® digital readout system
- Fine adjustment on all axes
- Quick release mechanism on the X-axis

OPTIONS

- Choice of six fixed magnification lenses including 10x, 20x, 25x, 31.25X, 50x and 100x
- Canopy and curtains (designed to mount on Starrett cabinet stand)
- Purpose built cabinet stand
- Work holding accessories

VB400 DIMENSIONS

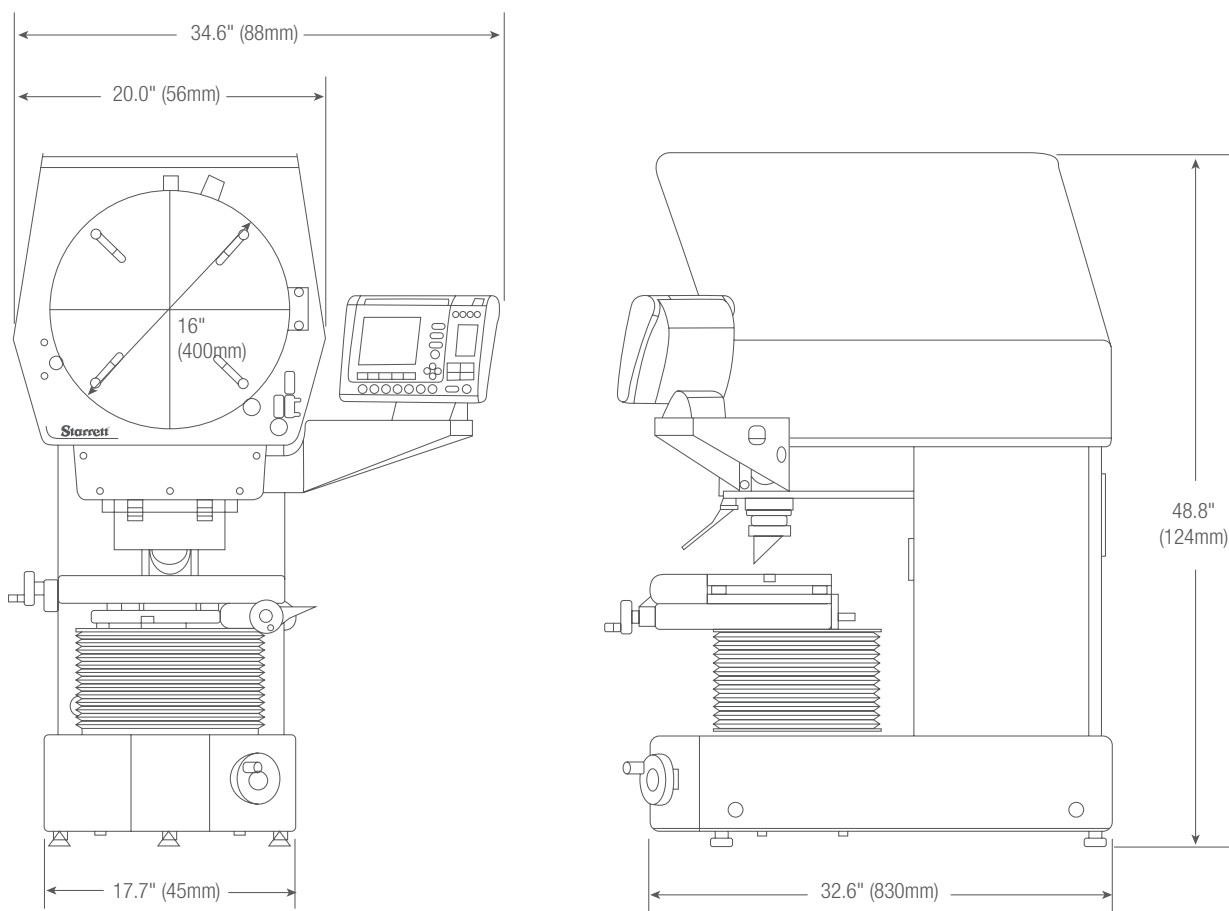

WEIGHT AND DIMENSIONS

	VB400
Net Weight	423lbs 192kg
Shipping Weight	443lbs 201kg
Shipping Dimensions (L x W x H)	49 x 32 x 51"

VERTICAL FLOOR STANDING OPTICAL COMPARATOR

VF600

If your measuring requirements demand the use of a large screen vertical axis comparator, then look no further than the VF600. Ideal for the larger components found in the electronics, stamping, and extrusion industries, the VF600 is the ultimate in vertical axis optical comparators; a design based on years of knowledge in the manufacture of high performing optical comparators.

OPERATOR INTERFACE

Feature	MetLogix™ M2	Quadra-Chek® QC221
Mounted to comparator arm	x	x
Color graphics	x	
Touch screen operation	x	
Operating system	Windows®	
X-Y-Z axis digital readout	x	x
2D geometry software with skew	x	x
Optical edge detection option	x	x
Software developer	MetLogix™	Metronics/Heidenhain



VF600

SPECIFICATIONS

VF600	
Horizontal Travel	8" (200mm)
Vertical Travel	4" (100mm)
Focus Travel	4" (100mm)
Top Plate*	16 x 9" (400 x 230mm)
Glass Insert	9-1/4 x 5-1/2" (235 x 140mm)
Image	Inverted and reversed

*With machined slots for easy fixturing

FEATURES AND SPECIFICATIONS

- Available with MetLogix™ M1 tablet, M2 measuring software with touch-screen with PC, or Quadra-Chek® digital readout system
- Screen is angled 30° from horizontal for clear, easy viewing
- Projection lens turret with three lens capacity (lenses not included)
- Turret mounted condenser system complete with two lenses and yellow/green filter with provision to mount further accessories
- Full canopy and curtains
- Linear encoder (glass scale) on both X and Y axes

OPTIONS

- Choice of five fixed magnification lenses including 10x, 20x, 25x, 50x and 100x
- 5x fixed lens by special order
- Automatic edge detection
- Motorized X-Y axis
- Fully automatic CNC controls

VF600 DIMENSIONS

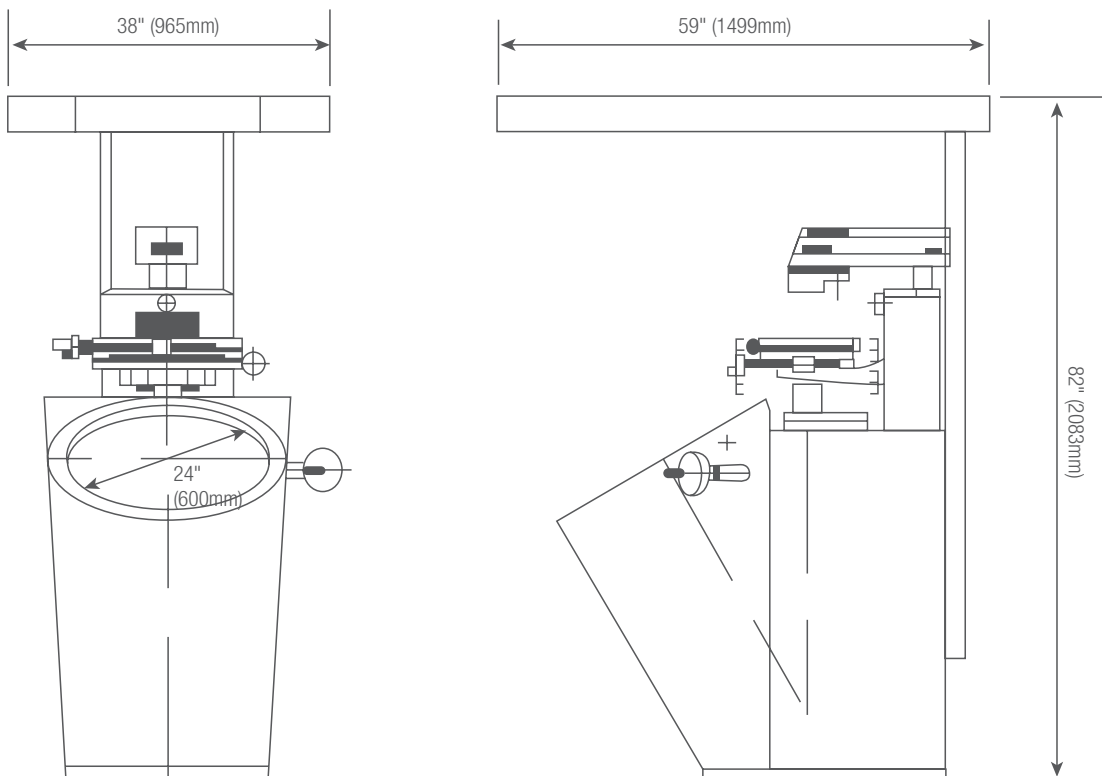

WEIGHT AND DIMENSIONS

	VF600
Net Weight	507lbs 230kg
Shipping Weight	937lbs 425kg
Shipping Dimensions	60 x 47 x 81" 152 x 120 x 206cm



HORIZONTAL FLOOR STANDING OPTICAL COMPARATOR

HF600

Well known throughout the world for superior value and exceptional measuring performance across the full measuring range and at all magnifications, the HF600 sets the standard in all applications from the QC lab to the production floor. The HF600 comparator has a four-position lens turret for instant selection of optional magnification lenses. Inserting the optional OV2 or TOV2 Video Camera System converts the comparator into a video metrology system. Ideal for use over a broad spectrum of industries and applications, the HF600 is designed and built to satisfy the requirements of measuring small to large work pieces with total precision, ruggedness, and efficiency. The HF600 utilizes 2D measurement software for geometries like diameters, radius, angles, lines, points, and for skew correction. Advanced software can also provide many tools such as CAD file import, CAD data export for reverse engineering, standard and custom reports, and Ethernet networking.

OPERATOR INTERFACE

Feature	MetLogix™		Quadra-Chek®	
	M2	M3	QC221	QC5200*
Mounted to comparator arm	x		x	
Color graphics	x	x		x
Touch screen operation	x	x		
Operating system	Windows®	Windows®		
X-Y-Z axis digital readout	x	x	x	x
2D geometry software with skew	x	x	x	x
Optical edge detection option	x	x	x	x
Video edge detection option		x		x
CAD file import and export option		x		x
CNC drive option	x	x	x	x
Software developer	MetLogix™	MetLogix™	Metronics/Heidenhain	Metronics/Heidenhain

*Available with either optical edge detection or video edge detection



HF600

SPECIFICATIONS

HF600	
Horizontal Travel	12" (300mm)
Vertical Travel	8" (200mm)
Focus Travel	3" (75mm)
Top Plate*	25 x 9" (635 x 230mm)
Image	Erect and reversed

*With machined slots for easy fixturing

FEATURES AND SPECIFICATIONS

- All metal construction with nickel plated stage tooling plate
- 24" (600mm) diameter screen with precision cross lines and overlay clips
- Motorized X and Y axes standard
- Two-axis power drive via joystick and variable speed control for fine adjustment
- Projection lens turret with four lens capacity (lenses not included)
- Turret mounted condenser system and yellow/green filter and provision to mount further accessories
- Stage Weight Capacity: 330lbs (150kg) (evenly distributed)
- Workstage capacity between centers: 17.5" (440mm)
- Fully retractable duplex fiber optic surface illumination
- 0.001mm resolution Heidenhain linear scales
- Screen driven rotary Q-axis with 1' resolution
- Available with MetLogix™ M1 tablet, M2 or M3 measuring software with touch screen and PC, or Quadra-Chek® digital readout systems
- Complete with full canopy and curtains

OPTIONS

- Six interchangeable lens magnification including 10x, 20x, 25x, 31.25x, 50x and 100x
- Optional 5x fixed or 5x interchangeable on a 3-lens turret available by special order
- Interchangeable OV2 video camera system with a 6.5:1 zoom lens
- Interchangeable TOV2 telecentric video camera systems with choice of 0.16x, 0.3x or 0.5x fixed magnification lenses
- Extended Stage Travel: 20" (500mm) X-axis; 8" (200mm) Y-axis
- Fully automatic CNC controls
- Automatic Optical Edge Detection
- Automatic Video Edge Detection available only with OV2 and TOV2 video camera systems
- Swing-away lamp house
- Extensive line of accessories

HF600 DIMENSIONS

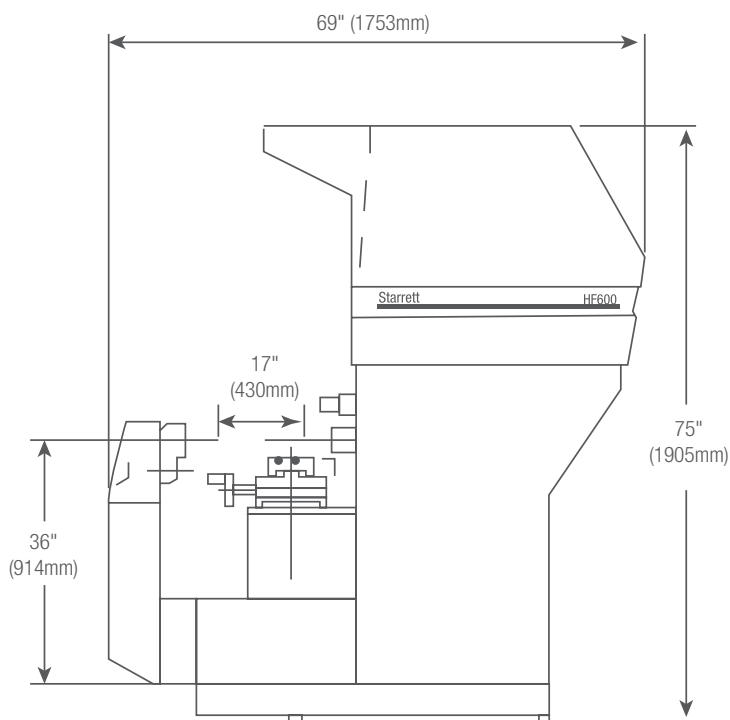
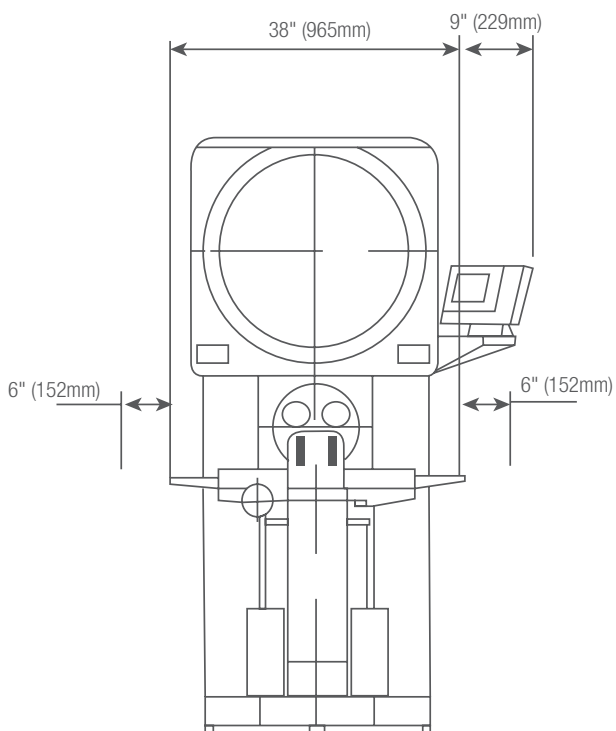

WEIGHT AND DIMENSIONS

	HF600
Net Weight	1340lbs 610kg
Shipping Weight	1500lbs 680kg
Crated Dimensions	81 x 49 x 89" 206 x 125 x 226cm

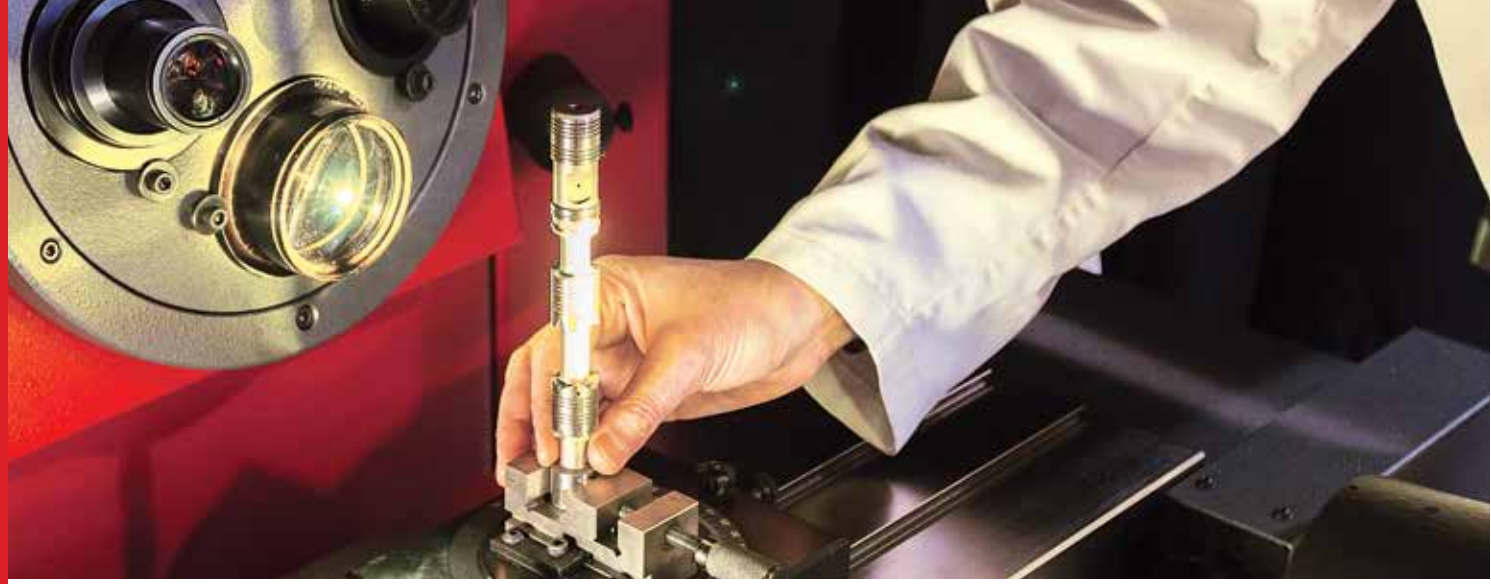

HORIZONTAL FLOOR STANDING OPTICAL COMPARATOR

HF750

Utilizing the same exemplary build standards as the HF600, the HF750 super capacity optical comparator delivers benefits from an even larger 30" (762mm) screen, setting a new standard for clarity and brightness. Ideal for use over a broad spectrum of industries and applications, the HF750 is designed and built to satisfy the requirements of measuring small to large work pieces with total precision, ruggedness, and efficiency. The geometric software measures diameter, radius, angle, line and point features, plus part skewing for faster setup. The HF750 is available with optical edge detection or video edge detection with advanced software and OV2 or TOV2 video camera options.

OPERATOR INTERFACE

Feature	MetLogix™		Quadra-Chek®	
	M2	M3	QC221	QC5200*
Mounted to comparator arm	x		x	
Color graphics	x			x
Touch screen operation	x	x		
Operating system	Windows®	Windows®		
X-Y-Z axis digital readout	x	x	x	x
2D geometry software with skew	x	x	x	x
Optical edge detection option	x	x	x	x
Video edge detection option		x		x
CAD file import and export option		x		x
CNC drive option	x	x	x	x
Software developer	MetLogix™	MetLogix™	Metronics/Heidenhain	Metronics/Heidenhain

*Available with either optical edge detection or video edge detection



HF750

SPECIFICATIONS

HF750

Horizontal Travel	12" (300mm)
Vertical Travel	8" (200mm)
Focus Travel	3" (75mm)
Top Plate*	25 x 9" (635 x 230mm)
Image	Erect and reversed

*With machined slots for easy fixturing

FEATURES AND SPECIFICATIONS

- All metal construction with nickel plated stage tooling plate
- 30" (762mm) diameter screen with precision cross lines and overlay clips
- Motorized X and Y axes standard
- Two-axis power drive via joystick and variable speed control for fine adjust
- Projection lens turret with three lens capacity (lenses not included)
- Turret mounted condenser system and yellow/green filter and provision to mount further accessories
- Stage Weight Capacity: 330lbs (150kg) (evenly distributed)
- Workstage capacity between centers 17.5" (440mm)
- Fully retractable duplex fiber optic surface illumination
- Halogen profile and surface illumination
- 0.001mm resolution Heidenhain linear scales
- Screen driven rotary Q-axis with 1' resolution
- Available with MetLogix™ tablet, M2 measuring software with touch screen and PC, or Quadra-Chek® digital readout systems
- Complete with full canopy and curtains

OPTIONS

- Six interchangeable lens magnifications including 10x, 20x, 25x, 31.25x, 50x and 100x
- Optional 5x fixed or 5x interchangeable on a 3-lens turret available by special order
- Interchangeable OV2 video camera system with 6.5:1 zoom lens
- Interchangeable TOV2 telecentric video camera systems with choice of 0.16x, 0.3x or 0.5x fixed magnification lenses
- Extended Stage Travel: 20" (500mm) X-axis; 8" (200mm) Y-axis
- Fully automatic CNC controls
- Automatic Optical Edge Detection
- Automatic Video Edge Detection available only with OV2 and TOV2 video camera systems
- Swing-away lamp house
- Extensive line of accessories

HF750 DIMENSIONS

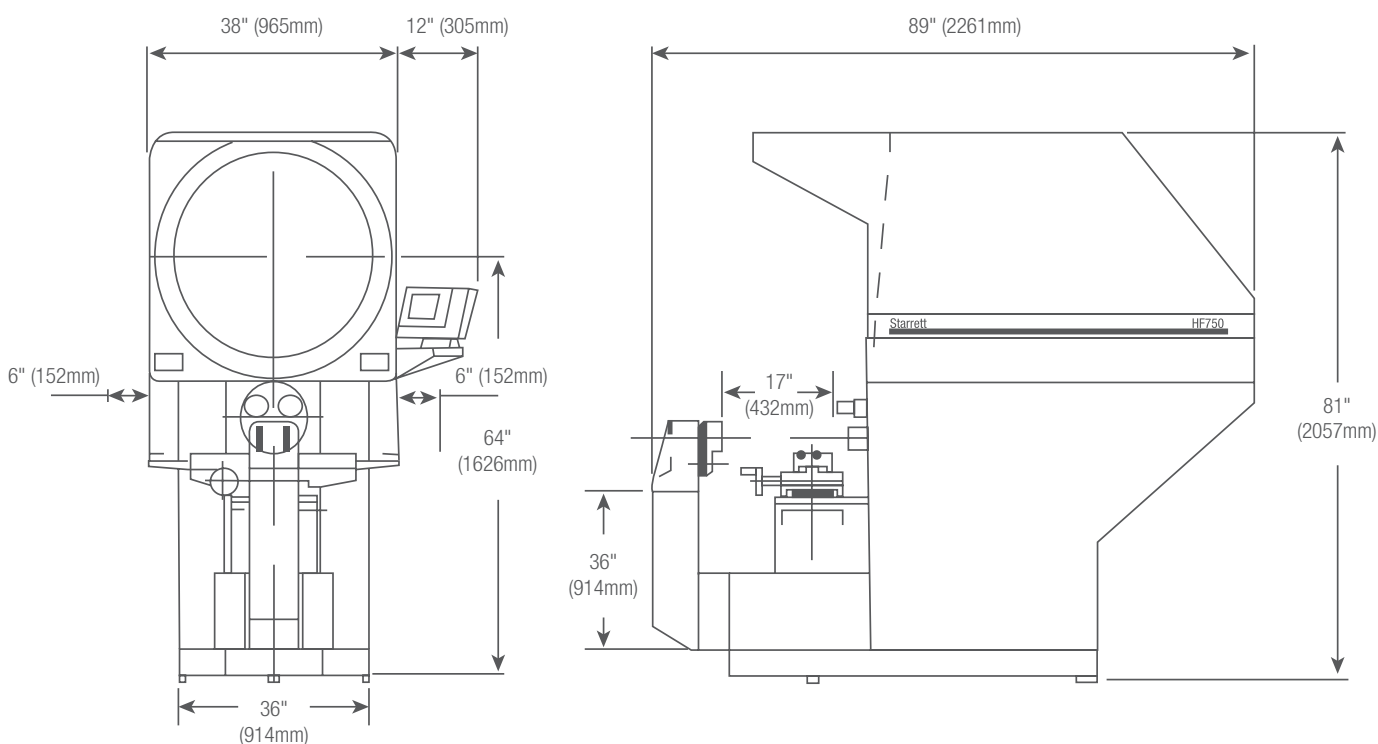

WEIGHT AND DIMENSIONS

	HF750
Net Weight	1660lbs
	753kg
Shipping Weight	1800lbs
	817kg
Crated Dimensions	96 x 48 x 91"
	244 x 124 x 231cm

SIDE BED OPTICAL COMPARATORS

HS600

The HS600 floor-standing horizontal optical comparator has all the same features as the HF600, except it has the screen position set to the side of the workstage area allowing close, comfortable and unrestricted access to the viewing and control area. A time tested, cost-effective solution for non-contact measurement. At the heart of these systems are precision optics, superb lighting, and a highly accurate workstage that combine to ensure bright, sharp images and exceptional accuracy. The HS600 is simple to use, yet has excellent capacity and performance to satisfy an exceptionally wide range of dimensional inspection applications and complex measuring requirements.

OPERATOR INTERFACE

Feature	MetLogix™		Quadra-Chek®	
	M2	M3	QC221	QC5200*
Mounted to comparator arm	x		x	
Color graphics	x	x		x
Touch screen operation	x	x		x
Operating system	Windows®	Windows®		
X-Y-Q axis digital readout	x	x	x	x
X-Y axis digital readout				
2D geometry software with skew	x	x	x	x
Optical edge detection option	x	x	x	x
Video edge detection option		x		x
CAD file import and export option		x		
CNC drive option	x	x	x	x
Software developer	MetLogix™	MetLogix™	Metronics/Heidenhain	Metronics/Heidenhain

*Available with either optical edge detection or video edge detection



HS600

SPECIFICATIONS

HF750	
Horizontal Travel	12" (300mm)
Vertical Travel	8" (200mm)
Focus Travel	3" (75mm)
Top Plate	25 x 9" (635 x 230mm)
Image	Inverted and reversed

FEATURES AND SPECIFICATIONS

- All metal construction with nickel plated stage tooling plate
- 24" (600mm) diameter screen with precision cross lines and overlay clips
- Motorized X and Y axes standard
- Two-axis power drive via joystick and variable speed control for fine adjustment
- Projection lens turret with four lens capacity (lenses not included)
- Turret mounted condenser system and yellow/gree filter and provision to mount further accessories
- Stage Weight Capacity: 330lbs (150kg) (evenly distributed)
- Workstage Capacity Between Centers: 17.5" (440mm)
- Fully retractable duplex fiber optic surface illumination
- Halogen profile and surface illumination
- 0.001mm resolution Heidenhain linear scales
- Screen driven rotary Q-axis with 1' resolution
- Available with MetLogix™ M2 or M3 measuring software with touch screen and PC, or Quadra-Chek® digital readout systems
- Complete with full canopy and curtains

OPTIONS

- Six interchangeable lens magnifications including 10x, 20x, 25x, 31.25x, 50x and 100x
- Optional 5x fixed or 5x interchangeable on a 3-lens turret available by special order
- Interchangeable OV2 video camera system with 6.5:1 zoom lens
- Interchangeable TOV2 telecentric video camera systems with choice of 0.16x, 0.3x or 0.5x fixed magnification lenses
- Extended Stage Travel: 20" (500mm) X-axis; 8" (200mm) Y-axis
- Fully automatic CNC controls
- Automatic Optical Edge Detection
- Automatic Video Edge Detection available only with OV2 and TOV2 video camera systems
- Extensive line of accessories

HS600 DIMENSIONS

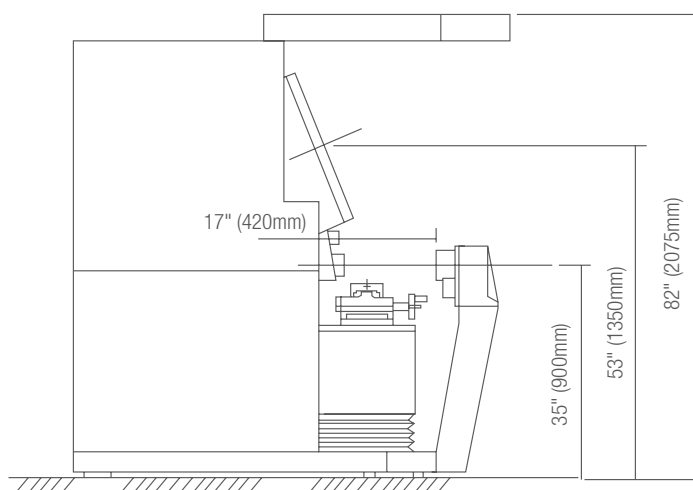
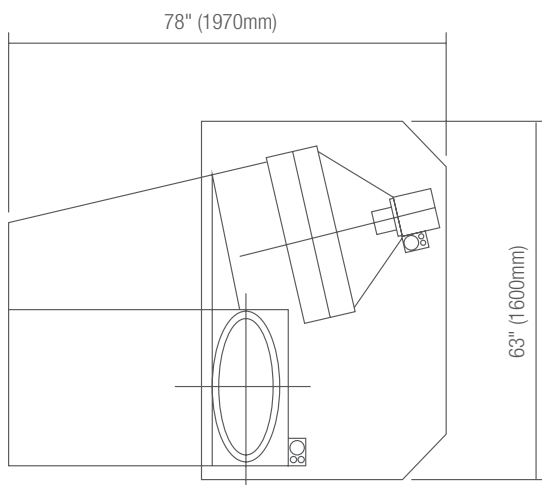

WEIGHT AND DIMENSIONS

	HS600
Net Weight	2315lbs 1050kg
Shipping Weight	2646lbs 1200kg
Dimensions (boxed)	83 x 89 x 93" 210 x 255 x 235cm

SIDE BED OPTICAL COMPARATORS

HS750

The HS750 floor-standing horizontal optical comparator has all the same features as the HF750 except that it has the screen position set to the side of the workstage area allowing close, comfortable and unrestricted access to the viewing and control area. At the heart of these systems are precision optics, superb lighting and a highly accurate workstage that combine to ensure bright, sharp images and exceptional accuracy. A time tested, cost-effective solution for non-contact measurement, the HS750 is simple to use, yet offers excellent capacity and performance to satisfy an exceptionally wide range of dimensional inspection applications and complex measuring requirements.

OPERATOR INTERFACE

Feature	MetLogix™	M3	Quadra-Chek®	
	M2		QC221	QC5200*
Mounted to comparator arm	x	x	x	
Color graphics	x	x		x
Touch screen operation	x	x		
Operating system	Windows®	Windows®		
X-Y-Q axis digital readout	x	x	x	x
2D geometry software with skew	x	x	x	x
Optical edge detection option	x	x	x	x
Video edge detection option		x		x
CAD file import and export option		x		
CNC drive option	x	x	x	x
Software developer	MetLogix™	MetLogix™	Metronics/Heidenhain	Metronics/Heidenhain

*Available with either optical edge detection or video edge detection



HS750

SPECIFICATIONS

HF750	
Horizontal Travel	12" (300mm)
Vertical Travel	8" (200mm)
Focus Travel	3" (75mm)
Top Plate*	25 x 9" (635 x 230mm)
Image	Inverted and reversed

*With machined slots for easy fixturing

FEATURES AND SPECIFICATIONS

- All metal construction with nickel plated stage tooling plate
- 24" (600mm) diameter screen with precision cross lines and overlay clips
- Motorized X and Y axes standard
- Two-axis power drive via joystick and variable speed control for fine adjustment
- Projection lens turret with four lens capacity (lenses not included)
- Turret mounted condenser system and yellow/green filter and provision to mount further accessories
- Stage Weight Capacity: 330lbs (150kg) (evenly distributed)
- Workstage Capacity Between Centers: 17.5" (440mm)
- Fully retractable duplex fiber optic surface illumination
- Halogen profile and surface illumination
- 0.001mm resolution Heidenhain linear scales
- Screen driven rotary Q-axis with 1' resolution
- Available with MetLogix™ M2 or M3 measuring software with touch screen PC, or Quadra-Check® digital readout systems
- Complete with full canopy and curtains

OPTIONS

- Six interchangeable lens magnification including 10x, 20x, 25x, 31.25x, 50x and 100x
- Optional 5x fixed or 5x interchangeable on a 3-lens turret available by special order
- Interchangeable OV2 video camera system with 6.5:1 zoom lens
- Interchangeable TOV2 telecentric video camera systems with choice of 0.16x, 0.3x or 0.5x fixed magnification lenses
- Extended Stage Travel: 20" (500mm) X-axis; 8" (200mm) Y-axis
- Fully automatic CNC controls
- Automatic Optical Edge Detection
- Automatic Video Edge Detection available only with OV2 and TOV2 video camera systems
- Extensive line of accessories

HS750 DIMENSIONS

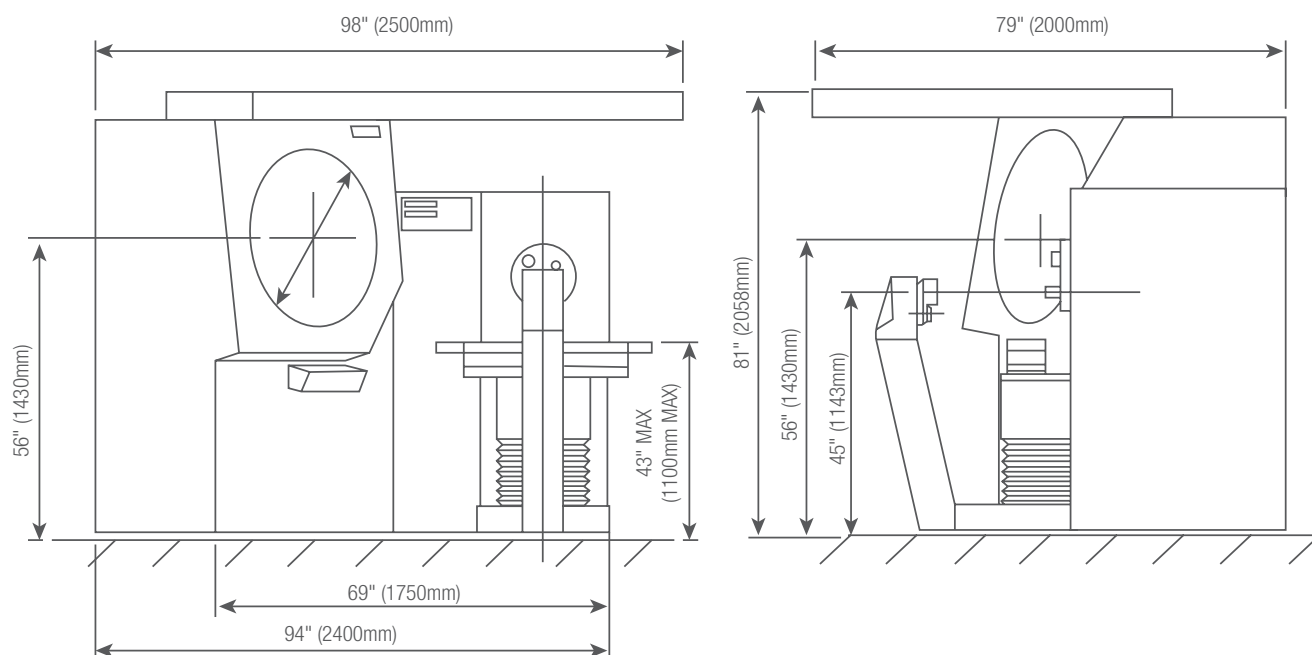

WEIGHT AND DIMENSIONS

	HS750
Net Weight	2932lbs 1330kg
Shipping Weight	3307lbs 1500kg
Dimensions (boxed)	119 x 94 x 91" 302 x 239 x 231cm

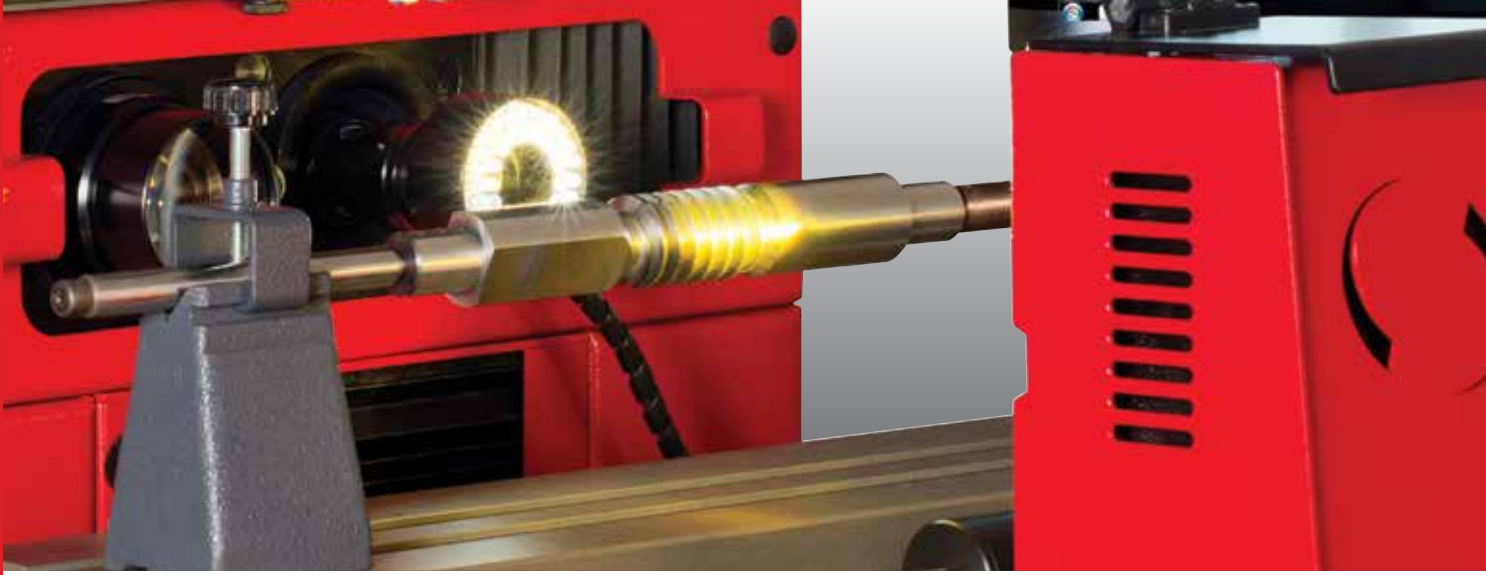

OV2™ OPTICAL COMPARATOR VIDEO ADAPTER

The OV2 is a special zoom lens and video camera adapter that can be interchanged with the fixed magnification lens on Starrett Optical Comparators. Combined with MetLogix™ M3 measuring software and touch-screen with PC, the result is a low cost video measuring system, expanding the versatility of your optical comparator! The OV2 is available as an option with new Starrett comparators and as an easy-to-install field retrofit. When used with the dual-lens HD400, and the HF600 and HF750 multi-lens turrets, the OV2 allows immediate access to both Video and Optical measurement without changing the part setup.

FEATURES AND SPECIFICATIONS

- Interchangeable bayonet style lens mount with 6.5:1 zoom lens, surface ring light and video camera creates a video measuring system
- Changeover between normal optical mode and OV2 is easy and fast
- Lens locks into comparator body and is pre-aligned
- Up to 1.25" (32mm) of working distance allows maximum stage travel utilization
- Video magnifications up to 240x
- Utilizes MetLogix™ M3 measuring software and touch-screen with PC for video display
- Maximizes existing investment to provide a low cost entry into video measurement technology
- Available for other makes of optical comparators, please call for more information



TOV2 OPTICAL COMPARATOR TELECENTRIC VIDEO ADAPTER

NEW!

The TOV2 telecentric lens and video camera can be interchanged with the fixed magnification lenses on Starrett Optical Comparators that utilize MetLogix™ M3 software. The TOV2 is available with a choice of 0.16x, 0.3x or 0.5x telecentric lenses as an option with new Starrett comparators and an easy-to-install field retrofit.

FEATURES AND SPECIFICATIONS

- Interchangeable bayonet-style lens mount with choice of 3 telecentric lenses, a surface ring light and video camera to create a video measuring system
- Offers a choice of .16x, .3x or .5x telecentric magnification lenses
- Changeover between normal optical mode and TOV2 is easy and fast
- Lens locks into comparator body and is pre-aligned
- Utilizes MetLogix™ M3 measuring software and a touch-screen with PC for video display
- Maximizes existing investment to provide a low cost entry into video measurement technology
- Available for other makes of optical comparators, please call for more information

OPTICAL COMPARATORS



M3 software display



SPECIFICATIONS AND OPTIONS

Model	HE400	HB400	HD400	VB300	VB400
Bench Top System	X	X	X	X	X
Floor-Standing System	-	-	-	-	-
Part View Orientation	Horizontal	Horizontal	Horizontal	Vertical	Vertical
Side Bed Version	-	-	-	-	-
Screen Diameter (in)	16"	16"	16"	12"	16"
Screen Diameter (mm)	400mm	400mm	400mm	300mm	400mm
X-Y Measuring Range (in)	10 x 4"	12" (16" optional) x 6"	16 x 6"	4 x 4"	8 x 4"
X-Y Measuring Range (mm)	250 x 100mm	300 (400mm optional) x 150mm	400 x 150mm	100mm x 100mm	200 x 100mm
Linear Glass Scale Encoder on X and Y Axis	Standard	Standard	Standard	Standard	Standard
Motorized X-Y Axis	-	Optional	Optional	-	-
CNC Control	-	Optional	Optional	-	-
Focus Range (in)	1.2"	2"	2"	3.5"	4"
Focus Range (mm)	30mm	50mm	50mm	90mm	100mm
Work Stage (in)	18.75 x 4.75"	21.25 x 5"	21.25 x 5"	8.8 x 8.8"	16 x 19"
Work Stage (mm)	475 x 120mm	540 x 130mm	540 x 130mm	225mm x 225mm	400 x 225mm
Load Capacity with Negligible Deflection (lbs)	15lbs	22lbs	22lbs	11lbs	22lbs
Load Capacity Maximum (lbs)	55lbs	110lbs	110lbs	15lbs	50lbs
Angular Measurement Resolution	1'	1'	1'	1'	1'
Profile Illumination	Standard	Standard	Standard	Standard	Standard
Surface Illumination	Standard	Standard	Standard	Standard	Standard
Quick Change Lens Mount (lenses not included)	Single	Single	Dual	Single	Single
Collimating Condenser with Yellow/Green Filter	Standard	Standard	Standard	Standard	Standard
Control System Software	QC100, QC200, M1, M2	QC100, QC200, QC5215, M1, M2, M3	QC100, QC200, QC5215, M1, M2, M3	LED Display, QC100, QC200, M1, M2	QC100, QC200, M1, M2
Display (control system dependent)	QC DRO, M1 tablet, 15" All-in-One touch screen PC	QC DRO, M1 tablet, 15" All-in-One touch screen PC, 24" touch screen monitor with PC	QC DRO, M1 tablet, 15" All-in-One touch screen PC, 24" touch screen monitor with PC	LED Display, QC DRO, M1 tablet, 15" All-in-One touch screen PC	QC DRO, M1 tablet, 15" All-in-One touch screen PC
Optical Edge Detection	Optional	Optional	Optional	Optional	Optional
Digital Video Camera System	-	Optional	Optional	-	-
Lenses - Screen Magnification (one required, not included)	10x, 20x, 25x, 31.25x, 50x, 100x	10x, 20x, 25x, 31.25x, 50x, 100x	10x, 20x, 25x, 31.25x, 50x, 100x	10x, 20x, 25x, 50x, 100x	10x, 20x, 25x, 31.25x, 50x, 100x
Iris Diaphragm	Optional	Optional	Optional	-	-
Precision Rotary Vise	Optional	Optional	Optional	-	-
Vee Block on Rotary Base	Optional	Optional	Optional	-	-
Precision Fixed Vise	Optional	Optional	Optional	-	-
Precision Centers and Vees	Optional	Optional	Optional	Optional	Optional
Helix Center Support System	-	-	-	-	Optional
Precision Rotary Work Stage	-	-	-	-	Optional
Glass Plate Work Holder	Optional	Optional	Optional	-	-
Field of View Diameter (in)	1.6, .8, .6, .5, .3, .15"	1.6, .8, .6, .5, .3, .15"	1.6, .8, .6, .5, .3, .15"	1.6, .8, .6, .3"	1.6, .8, .5, .3, .15"
Field of View Diameter (mm)	40, 20, 16, 13, 8, 4mm	40, 20, 16, 13, 8, 4mm	40, 20, 16, 13, 8, 4mm	40, 20, 16, 8mm	40, 20, 16, 8, 4mm
Working Distance (in)	3.1, 3, 2.5, 2.2, 2, 1.5"	3.1, 3, 2.5, 2.2, 2, 1.5"	3.1, 3, 2.5, 2.2, 2, 1.5"	3.1, 3, 2.5, 2"	3.1, 3, 2.5, 2, 1.5"
Working Distance (mm)	80, 76, 62, 57, 50, 41mm	80, 76, 62, 57, 50, 41mm	80, 76, 62, 57, 50, 41mm	80, 76, 62, 50mm	80, 76, 62, 50, 41mm
Cabinet Stand 32"	Optional	Optional	Optional	Optional	Optional
Cabinet Stand 23"	Optional	Optional	Optional	Optional	Optional
Canopy and Curtains	Optional	Optional	Optional	Optional	Optional

VF600	HF600	HF750	HS600	HS750
-	-	-	-	-
X	X	X	X	X
Horizontal	Horizontal	Horizontal	Horizontal	Horizontal
-	-	Standard	Standard	Standard
24"	30"	24"	30"	30"
600mm	750mm	600mm	750mm	750mm
12" (20" optional) x 8"	12" (20" optional) x 8"	12" (20" optional) x 8"	12" (20" optional) x 8"	12" (20" optional) x 8"
300 (500mm optional) x 200mm	300 (500mm) x 200mm	300 (500mm) x 200mm	300 (500mm optional) x 200mm	300 (500mm optional) x 200mm
Standard	Standard	Standard	Standard	Standard
Standard	Standard	Standard	Standard	Standard
-	Optional	Optional	Optional	Optional
3"	3"	3"	3"	3"
75mm	75mm	75mm	75mm	75mm
25 x 9" (Optional 32" 8")	25 x 9" (Optional 32" 8")	25 x 9" (Optional 32" 8")	25 x 9" (Optional 32 x 8")	25 x 9" (Optional 32 x 8")
630 x 230mm	630 x 230mm	630 x 230mm	630 x 230mm	630 x 230mm
110lbs	110lbs	110lbs	110lbs	110lbs
330lbs	330lbs	330lbs	330lbs	330lbs
1'	1'	1'	1'	1'
Standard	Standard	Standard	Standard	Standard
Standard	Standard	Standard	Standard	Standard
4 Lens Turret	3 Lens Turret	4 Lens Turret	3 Lens Turret	3 Lens Turret
Standard	Standard	Standard	Standard	Standard
QC200, M2	QC200, QC5215, M2, M3	QC200, QC5215, M2, M3	QC200, QC5215, M2, M3	QC200, QC5200, M2, M3
QC DRO, 15" All-in-One touch screen PC	QC DRO, 15" All-in-One, 21" touch screen PC, 24" touch screen monitor with PC	QC DRO, 15" All-in-One, 21" touch screen PC, 24" touch screen monitor with PC	QC DRO, 15" All-in-One, 21" touch screen PC, 24" touch screen monitor with PC	QC DRO, 15" All-in-One, 21" touch screen PC, 24" touch screen monitor with PC
Optional	Optional	Optional	Optional	Optional
-	Optional	Optional	Optional	Optional
10x, 20x, 25x, 50x, 100x	10x, 20x, 25x, 31.25x, 50x, 100x	10x, 20x, 25x, 31.25x, 50x, 100x	10x, 20x, 25x, 31.25x, 50x, 100x	10x, 20x, 25x, 31.25x, 50x, 100x
Optional	Optional	Optional	Optional	Optional
-	Optional	Optional	Optional	Optional
-	Optional	Optional	Optional	Optional
-	Optional	Optional	Optional	Optional
Optional	Optional	Optional	Optional	Optional
Optional	-	-	-	-
Optional	-	-	-	-
-	Optional	Optional	Optional	Optional
2.3, 1.2, .9, .5, .2"	3, 1.5, 1.2, .6, .3"	2.3, 1.2, .9, .5, .2"	3, 1.5, 1.2, .6, .3"	3, 1.5, 1.2, .6, .3"
60, 30, 24, 12, 6mm	75, 37.5, 30, 15, 7.5mm	60, 30, 24, 12, 6mm	75, 37.5, 30, 15, 7.5mm	75, 37.5, 30, 15, 7.5mm
5.4, 5, 4, 3.5, 1.7"	6, 4, 3.6, 2.3, 1.9"	5.4, 5, 4, 3.5, 1.7"	6, 4, 3.6, 2.3, 1.9"	6, 4, 3.6, 2.3, 1.9"
138, 127, 103, 88, 44mm	151, 101, 92, 60, 48mm	138, 127, 103, 88, 44mm	151, 101, 92, 60, 48mm	151, 101, 92, 60, 48mm
-	-	-	-	-
-	-	-	-	-
Standard	Standard	Standard	Standard	Standard

ACCESSORIES

Starrett offers a full range of accessories and purpose-built cabinet stands designed for our optical comparator systems to ensure efficient system setup for a broad range of applications.



Photo Key	Part No.	Description	For Models
A	OCN8	Large Centers and Vees	HF600, HF750
B	ORV2	2-1/32" Capacity Rotary Vise	HF600, HF750
C	4U000 0GH1 0GH2	Magnification Checking Graticule	HE/HB/HD400 and VB400 HF600 HF750
D	OCN7	Small Centers and Vees	HF600, HF750
E	7P000	Centers and Vees	HE/HB/HD400
F	9W000 3V000	Helix Center Support Fixture	VB300, VB400, VF600
G	6H000	Centers and Vees	VB400, VF600
H	OVH1	Vertical Glass Plate Holder	HF600, HF750
J	7U000	Vertical Glass Plate Holder	HE/HB/HD400
K	4H003	Rotary Vise with 1-1/4" Capacity	HE/HB/HD400, HF600, HF750
M	6U003	Rotary Work-stage	VB400, VF600 for use on 200mm x 100mm workstage
N	4H002	Fixed Position Vise with 1-1/4" Capacity	HE/HB/HD400, HF600, HF750
P	4H004	Universal Vee Block on Rotary Base	HE/HB/HD400, HF600, HF750
S	P-10095 P-10102	32" Cabinet Stand 23" Cabinet Stand	HE400, HB400, HD400, VB300, VB400
T*	P-10485	Canopy and Curtains designed to be used with Starrett cabinet stand	HE400, HB400, HD400, VB300, VB400

*Product not shown



SOFTWARE

METLOGIX™ SOFTWARE

M1, M2 AND M3

FOR OPTICAL COMPARATORS

Graphics rich display, large icon buttons, and intuitive operation. Coordinate display for X and Y linear axes and Q angular values for screen rotation. Easy part alignment and datum function.



M1 shown
on HE400



M2 shown

FEATURES

- Clean and simple touchscreen interface with large icon buttons and intuitive operation
- Graphics-rich display providing instant information on feature form, tolerances, and measurement data
- Coordinate display for X and Y linear axes and Q angular values for screen rotation
- Easy part alignment and datum functions
- Measure and tolerance these geometric features: point, line, angle, distance, radius, diameter
- As you measure, a part view is created in the feature view. Constructions between features such as distances and bolt hole pattern can be done by simple selections from the part view.
- For repetitive part measurement, create a part program that will visually guide operators through part measurement
- Optional optical edge detection provides better throughput and removes operator subjectivity
- Video edge detection option on M3 only
- Four different report forms can be printed or exported to Microsoft Excel, text files, or to an SPC program
- M2 and M3 utilize a Windows®-based operating system enables flexible data export and interface capability
- M1 utilizes an Android operating system and a Bluetooth® connection to the host Optical Comparator
- Fast, easy connection to printers and networks

M1, M2 AND M3

MetLogix™ control software provides a broad range of powerful, user-friendly functions on a compact, icon-based touchscreen interface in place of the traditional control.

	MetLogix™ M1	MetLogix™ M2	MetLogix™ M3
Mounted to comparator arm	x	x	
Color graphics	x	x	x
Touch-screen operation	x	x	x
Operating system	Android	Windows®	Windows®
X-Y-Q (angle) measurements	x	x	x
2D geometry software with skew	x	x	x
Optical edge detection option	x	x	x
Video edge detection option			x
CAD file import and export option		x	x
CNC drive option		x	x

M3

FOR VISION SYSTEMS

Multi-touch software control that can pan and zoom with pinch, swipe, or touch. Works with active part views and live video feeds (or use the conventional mouse interface). Custom "Eye Measure" probe captures complex edges generated by a finger path drawn on the touch screen. Measure Logic probe intelligence provides instant feature determination and measurement with a single touch.



Intuitive graphic menu



Display flexibility or export the measurement report

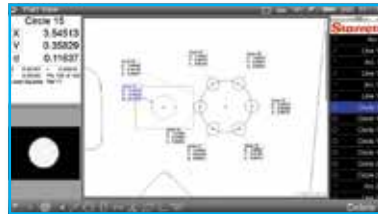

Graphic window with selectable Features and notes



Graphical window with the selected data points

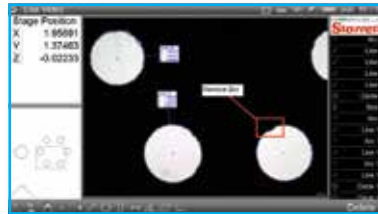

Live video image with data from selected points

FEATURES

- DXF CAD file import for comparing parts being inspected to the actual design file; no need for cumbersome Mylar overlays
- "Vtouch" Probe has video touch probe functionality – just click for simple acquisition of points on a feature's edge
- Part View can generate distance and tangent lines from within the graphical part view. The "Gesture Menu" can be used for feature creation and manipulation tools.
- "Quick Annotate" allows data on several features to be displayed simultaneously with smart marquee feature selection
- Application of universal tolerance value entry according to feature resolution groupings
- Feature Detail Graphics: Individual feature views display point cloud distributions, nominal deviations, and tolerance results. Scroll through Actual, Nominal, Tolerance, Deviation and Data Fit Type information
- Simple machine/camera calibration with popular machine and video correction methods
- Windows®-based, globally recognized OS for flexible data exporting and interface with Windows® applications
- DC (FOV) software option



Software MetLogix™ M3 with touch touchscreen interface

QUADRA-CHEK[®] SOFTWARE

Modern metrology is a complex sequence of measuring, recording, analyzing and reporting dimensional data. The conceptual model underlying the Quadra-Chek[®] digital readout design organizes the work-flow to support operators at every stage of the measurement process.

QC100

- Perform 2 and 3 axis measurements at very high levels of precision and accuracy
- Measurements viewed on the front panel LCD can be transmitted to a PC over a standard serial port connection, or to a printer over a parallel or serial port

QC200

Metrology DRO requires a video monitor display and cross-hair generator in vision configuration. QC200 is a time-saving measurement tool with patented Measure Magic[®] technology. Ideal for measuring 2D features on Optical Comparators and Manual Vision Machines.

- Inch/metric conversion, toggle between incremental/absolute and simple zero reset
- Skew function for ease of part alignment
- Integrated geometric tolerancing allowing for pass/fail measurements
- Simple part programming with measure guide
- USB and RS232 Interface
- Linear and segmented linear error correction
- Intuitive displays
- Crisp, clear, bright black and white LCD display
- Optional optical edge for comparators



QC100

QC200



QC5200

Metrology software utilizes a Windows® 64-bit operating system for video measuring machines.

The QC5200 supports a wide range of industries that require precise measurement and inspection of 2D parts using a single sensor. This product features an intuitive user interface and simple, meaningful visual displays. The design reflects a deep understanding of the user's needs along with a process model that supports the operator at every stage in the measurement process.

FEATURES

- 2D capabilities
- 2D part profiling
- Advanced calculation capabilities
- Advanced geometric tolerancing
- Alternate algorithms
- Auto-focus
- Auto program from CAD files
- Continuous edge mode
- CNC part positioning and automated measurement
- Customizable screen layouts
- Data cloud analysis
- Data export to wide variety of applications
- Image capture with drag and drop data reporting
- Integrated runs database
- Intuitive program editing capability
- Multiple reference frames
- Multiple language support
- Patented Measure Magic technology
- Powerful yet intuitive video edge detection tools

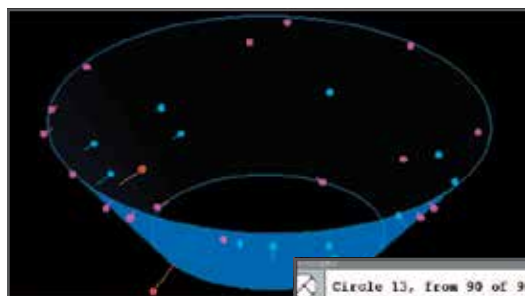

Data Cloud Alternate fits



QC5300

Metrology software picks up where the QC5200 leaves off. This product offers multi-axis dimensional measurement of 2D and 3D parts. The QC5300 integrates an innovative user interface, state of the art ergonomics, powerful data import, export and data analysis tools.

FEATURES

- 3D capabilities
- 3D data clouds
- 3D measurement set
- 3D offset alignments
- 3D part view
- 3D part profiling option
- Image processing tools
- Pattern recognition
- Renishaw touch probe compatibility
- Optical laser sensor
- "X-Y" 2D measurements with optional "Z" Axis for height measurements
- Vector probing

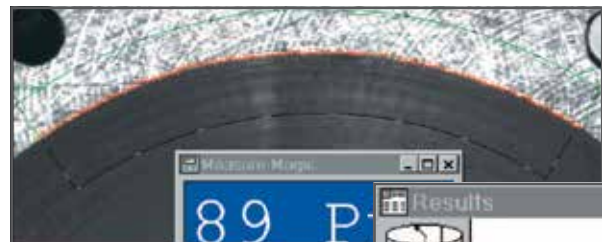

Measure Magic

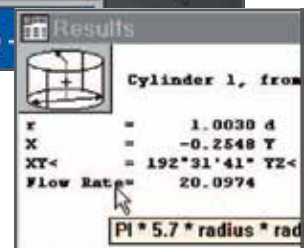

Image View

MMC Tolerance Results			
Position	Nominal	Actual	Error
X	22.5620	22.5618	0.0002
Y	0.0708	0.0699	0.0009
Z	10.5466	10.5466	0.0000
Size			
	Nominal	Actual	Deviation
Ø	1.8650	1.8657	0.0007

Tolerance

Integrated Database	
1.0710	HELL 0150
1.0709	
1.0707	
1.0700	
1.0695	
1.0709	
1.0713	
1.0713	
1.0710	
1.0712	
1.0713	
1.0708	
1.0700	
1.0700	

Integrated Database

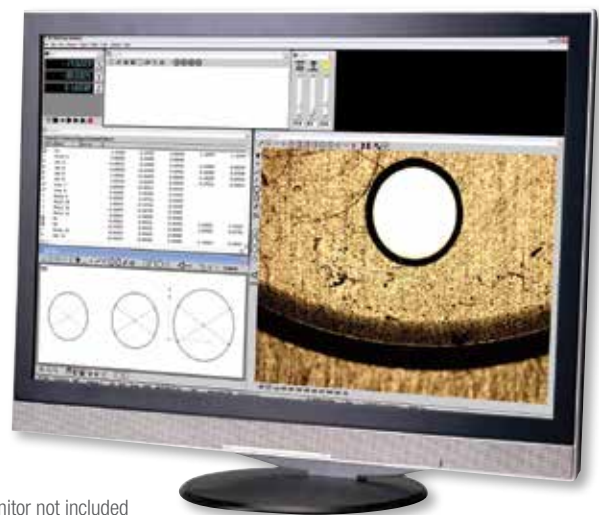

Monitor not included

D1 INSPECTION SOFTWARE

FEATURES

- View and manipulate live and static images from a variety of inspection devices on any Windows® based operating system. Mouse/Keyboard and touchscreen systems are supported.
- A simplified operating interface requires only a few quick clicks to capture, mark up, export, print and email images directly from your inspection equipment
- Zoom and Pan the camera feed until the desired image is displayed. Add custom text, and graphic elements to generate detailed image capture for defect reporting and to improve overall visual communication of parts and component characteristics.
- Perform basic calculations of feature size, position, and orientation using a simple cross-hair tool. Translate or rotate the cross-hair tool within the image window to probe circle, line, point, and angle features within the field of view.
- Add feature annotation directly to selected features to display size, position and orientation results on either the video frame or within a blank part view space
- Access previously stored images easily in the thumbnail image list. Convenient date and time stamps are added to help sort and review collections of images.

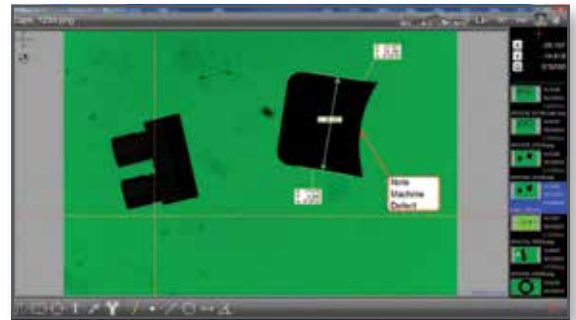
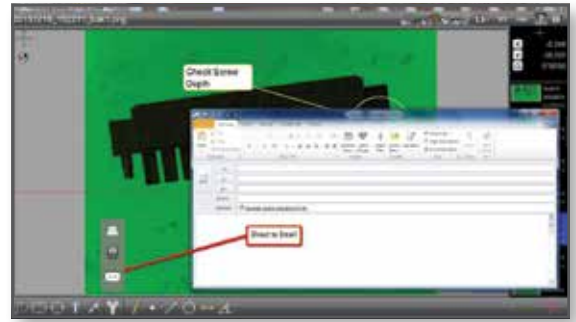

D1 Software display

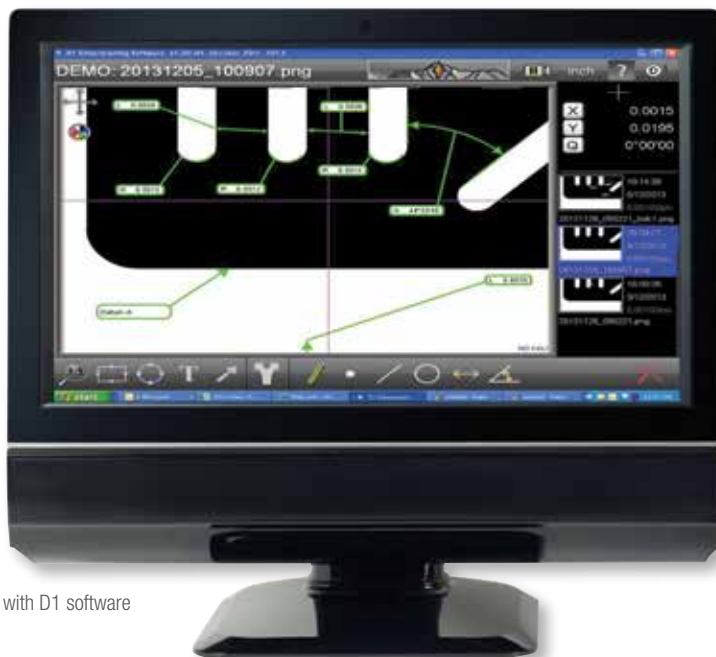

KineMic - KMR with D1 software





PRECISION MAKES THE DIFFERENCE

NO CONTACT IS THE SOLUTION.

Profile360™ is an in-line, real-time, non-contact solution for continuously monitoring key profile dimensions in complex shapes such as rubber, ceramic, plastic, and wood-plastic composite extrusions, roll-formed metal profiles, and profiled wire.

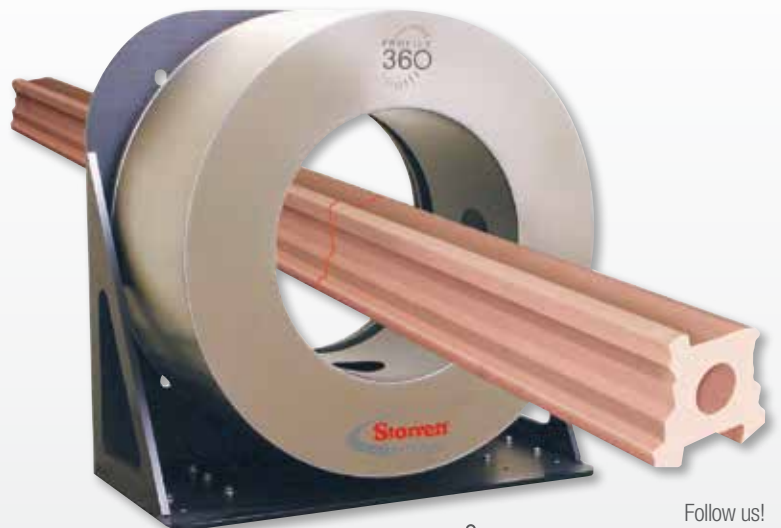

Starrett®

(978) 249-3551 • starrett.com

Follow us!



CONTACT INFORMATION GUIDE FOR NORTH AMERICA

COMPLETE, UP-TO-DATE CONTACT INFORMATION AVAILABLE AT STARRETT.COM

PRIMARY CONTACTS, SALES AND GENERAL INFORMATION

- **World Headquarters and Precision Tools:**
Athol, MA, (978) 249-3551
- **Metrology Equipment:**
Laguna Hills, CA, (949) 348-1213
- **Laser Measurement:**
Columbus, GA, (706) 323-5142
- **Granite Surface Plates and Accessories:**
Waite Park, MN, (320) 251-7171
- **Gage Blocks:**
Cleveland, OH, (440) 835-0001
- **Mexico:**
Saltillo, Coah, Mexico, (844) 432-4660

CALIBRATION

- **Precision Tools and Gages:**
Athol, MA, (978) 249-3551
- **Starrett Calibration Services:**
Duncan, SC, (864) 433-8407
- **Metrology Equipment:**
Laguna Hills, CA, (949) 348-1213
- **Granite Surface Plates and Accessories:**
Waite Park, MN, (320) 251-7171
- **Gage Blocks:**
Cleveland, OH, (440) 835-0001
- In Mexico, please call (844) 432-4660

REPAIR

- **Precision Tools and Gages:**
Athol, MA, (978) 249-3551
- **Metrology Equipment:**
Laguna Hills, CA, (949) 348-1213
- **Granite Surface Plates and Accessories:**
Waite Park, MN, (320) 251-7171
- **Gage Blocks:**
Cleveland, OH, (440) 835-0001
- In Mexico, please call (844) 432-46-60

CUSTOM SOLUTION DEVELOPMENT

- **Special Tools and Gages:**
Athol, MA, (978) 249-3551
- **Metrology System Development and Configuration:**
Laguna Hills, (949) 348-1213
- **Granite Based Custom Products:**
Waite Park, MN, (320) 251-7171
- In Mexico, please call (844) 432-4660

ADDITIONAL AND/OR UP-TO-DATE INFORMATION

- starrett.com
- Product Literature and Educational Materials:
Select the "Catalogs" button at starrett.com to order printed product information and to access literature PDFs for viewing and/or downloading
- In Mexico, please call (844) 432-4660

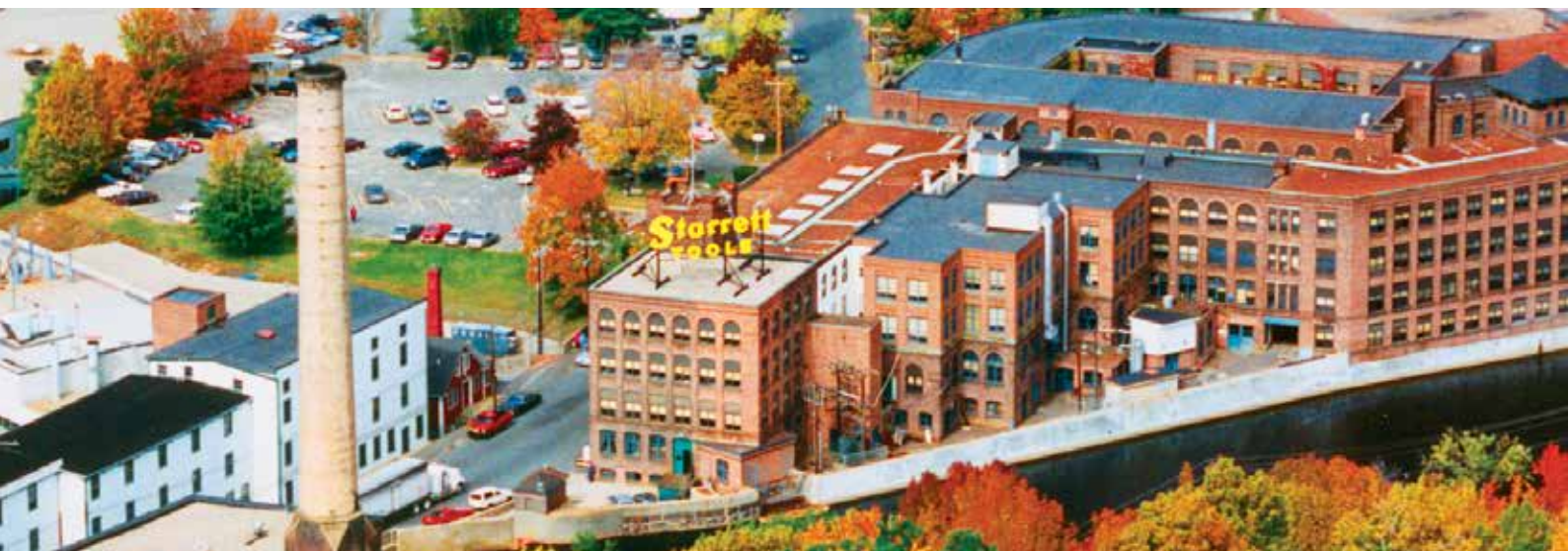

CORPORATE HEADQUARTERS AND MAIN FACTORY

THE L.S. STARRETT COMPANY

121 Crescent Street
Athol, MA 01331-1915 - U.S.A.

Tel: (978) 249-3551
Main Fax: (978) 249-8495

INTERNATIONAL LOCATIONS

BRAZIL

Starrett Indústria e Comércio Ltda.
Av. Laroy S. Starrett 1880 - Bairro Pinheirinho
Caixa Postal 171
13306-900 Itu, São Paulo - Brazil

Tel: 55 11 2118-8200
Fax: 55 11 2118-8003

SCOTLAND

The L.S. Starrett Company Ltd.
Jedburgh TD8 6LR - Scotland

Tel: 44 (0) 1835 863501
Fax: 44 (0) 1835 863018

CHINA

Starrett Tools (Suzhou) Company Limited
Suzhou Industrial Park
No. 339. Su Hong Zhong Road
Suzhou, Jiangsu Province
P.R. China 215021

Tel: 86 512 6741940
Fax: 86 512 67415697

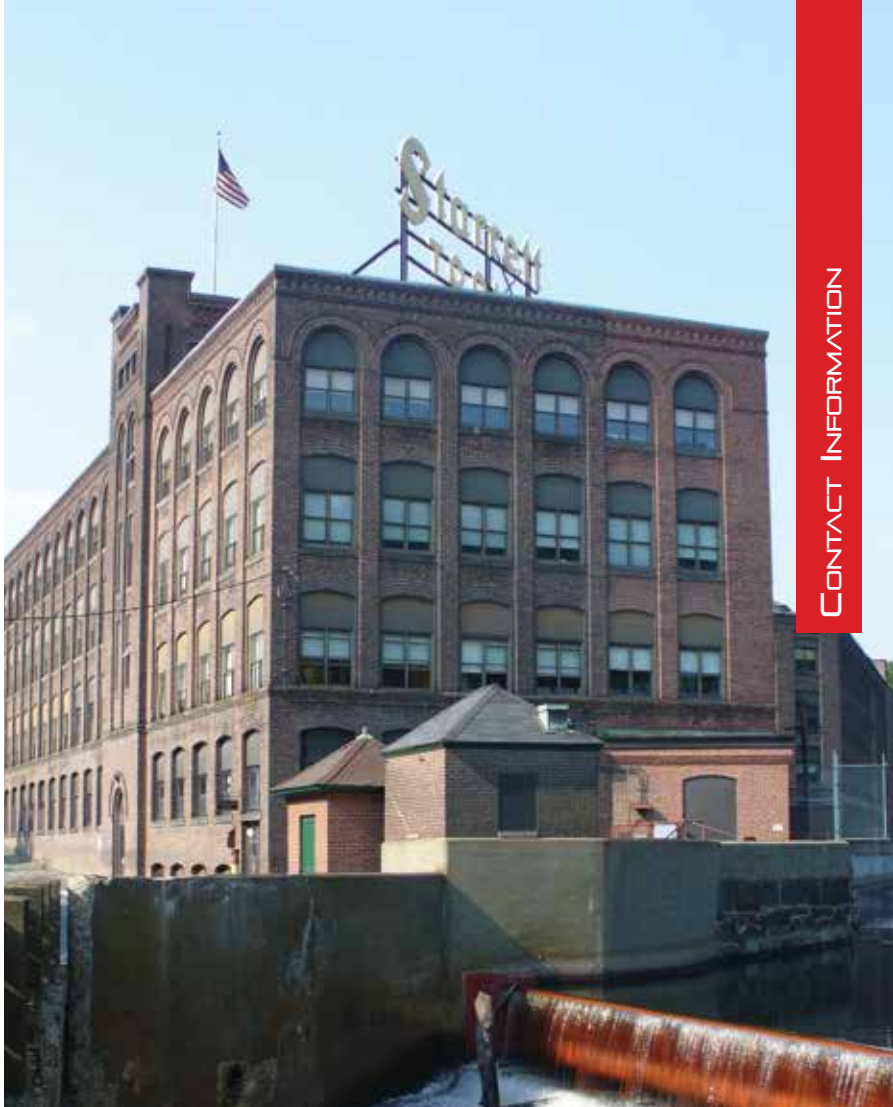

HOW TO ORDER

For prompt delivery, technical support and assistance, contact your nearest industrial distributor.

PRODUCT DEMONSTRATION

All Starrett manufacturing and branch locations and many distributors can demonstrate an array of Starrett products at work. Contact your local distributor to learn more.



STARRETT PRODUCT LINES

Band Saw Blades

Force Measurement

Jobsite & Workshop Tools

Laser Measurement

Metrology Equipment

Precision Granite

Precision Ground Solutions

Precision Measuring Tools

PTA & Hand Tools

Service

Webber Gage Blocks

METROLOGY SYSTEMS



Follow us!



starrett.com

Catalog 81

Metrology Systems

05/17

5M/Q

The L.S. Starrett Company 2015© Specifications subject to change.

Starrett®

Phone: (978) 249-3551 | Fax: (978) 249-8495
121 Crescent Street-Athol, MA 01331-1915-USA