



TIMKEN



TIMKEN® TAPERED ROLLER BEARING TYPE E HOUSED UNITS





TIMKEN® HOUSED UNIT CATALOG INDEX

| | |
|---|-----|
| OVERVIEW..... | 2 |
| INTRODUCTION..... | 4 |
| SHELF LIFE POLICY..... | 10 |
| Tapered Roller Bearing Type E Housed Units..... | B-1 |



GROW STRONGER WITH TIMKEN

Every day, people around the world count on the strength of Timken. Our expertise in metallurgy, friction management and mechanical power transmission helps them accelerate improvements in productivity and uptime.

We supply products and services that can help keep your operations moving forward, whether you need drive train kits for commercial vehicles, durable housings for bearings in dirty environments, couplings that avoid metal-to-metal contact between motors and gearboxes, repair services for rail bearings, steel for an aircraft engine shaft, or other products and services for your applications.

When you choose Timken, you receive more than high-quality products and services: You gain a worldwide team of highly trained and experienced Timken people committed to working collaboratively with you to improve your business.

Globally, our 20,000 people provide reliable answers for a wide range of operations in manufacturing, mining, medical equipment, aerospace, transportation, oil and gas – and other diverse industries.

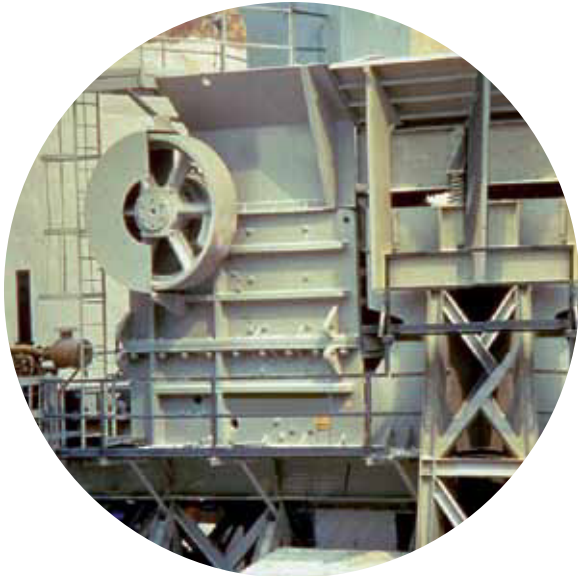

INCREASE YOUR EQUIPMENT UPTIME

In addition to high-quality bearings, engineered steel and mechanical power transmission components, we provide valuable integrated products and services. For example, we offer repair services and equipment monitoring equipment that can alert you to problems before they impact your uptime.

Additionally, we offer a broad selection of seals, premium lubricants, lubricators, couplings and chain to keep your operations moving smoothly.

Our 10 technology centers in the United States, Europe and Asia help pioneer tomorrow's innovations with extensive basic and applied scientific research programs. Through internal development and strategic acquisition of innovative companies, we continue to expand our portfolio of highly engineered bearings, steel and components.





RUGGED TIMKEN® HOUSED UNITS HELP PROTECT YOUR BEARINGS

When you choose sturdy Timken housings, your bearings can keep rolling smoothly, even in harsh environments impacted by dirt, debris, water and other contaminants. Timken engineers designed special housings to withstand tough challenges on the job.

Protected inside durable cast iron or steel, our highly engineered Timken® ball and roller bearings work hard to help you manufacture and transport materials, without excessive maintenance due to contaminants.

Choose from our selection of housed units designed with ball, tapered and spherical bearings. Select enhancements like Timken® seals, lubricants and housing covers best suited for each task. Our engineers help you choose the right combination of bearings and accessories to extend bearing life, increase uptime and reduce maintenance costs.

Of course, you can interchange existing products with Timken housed units because our bolt holes and shaft centerline dimensions are designed to conform to industry standards.

Timken® housed units reflect our strengths in metallurgy, engineering and manufacturing. We produce all our bearings in adherence with the Timken Quality Management System for consistency in all our facilities around the world.





TIMKEN® BALL HOUSED UNITS OFFER EASY INSTALLATION, FLEXIBLE OPTIONS

Timken® ball housed units, available in a variety of sizes and types, feature wide-inner-ring ball bearings that provide additional shaft support and locking options. The Timken® wide-inner-ring ball bearing is designed for straight shafts and can be positioned without shoulders, locknuts or adapters.

For easy installation, our ball housed units can be ordered pre-assembled with bearings, housings, seals and locking systems. Choose from pillow blocks, flanged cartridges, take-up units and cylindrical cartridges. Our cast-iron, pressed-steel and other optional materials give you durable choices for the exterior covers. Timken® locking options include set screws, self-locking collars and concentric collars.

Timken® Shaft Guarding Technology™ deters set-screw damage to shafts by placing a hardened band in the groove along the inner ring of the bearing. The set screws press against the band to transfer gripping pressure onto the shaft, preventing nicks, as well as raised-metal or permanent shaft damage. The stainless-steel band resists corrosion on the shaft. This system is particularly helpful for applications where it would be expensive and time-consuming to replace shafts.

TYPICAL INDUSTRIES AND APPLICATIONS

Use Timken ball bearing housed units in agricultural applications, fans, blowers, food processing devices and conveyors.





TIMKEN® TYPE E HOUSED UNITS REPEL CONTAMINANTS, ENHANCE PERFORMANCE

Timken® Type E tapered roller bearing housed units feature double-lip seals and locking collars that protect against water and other contaminants. This double-lip seal design blocks debris and retains grease better than single-lip or triple-lip seals, according to Timken 2012 laboratory tests.

Its cast-iron exterior includes a corrosion-resistant electro-coat finish for the housing and collar, a more durable shield than industry-standard powder coating or black oxide. Set screws with nylon patches reduce back-out, even in rigorous applications.

Premium Timken® tapered roller bearings inside Type E housings are manufactured with advanced technology that results in longer predicted useful bearing life than other housed units with standard bearings. Designed with optimized bearing profiles and improved surface finishes, Timken tapered roller bearings operate efficiently within the housing.

TYPICAL INDUSTRIES AND APPLICATIONS

Use Timken Type E housings for pulp and paper, power generation, mining, cement and aggregate industries. Our Type E housed units also are widely used in equipment for air-handling and treatment of water and waste water. Other common machine applications include mixers, washers, shredders, mills and oven/furnace roller beds.





TIMKEN® SPHERICAL ROLLER BEARING SOLID-BLOCK HOUSED UNITS WITHSTAND HARSH CONDITIONS

Timken® spherical roller bearing solid-block housed units stand up to rugged conditions. Composed of solid steel, they withstand most falling debris and handle up to ± 1.5 degrees of misalignment. The steel used in these products is up to two times stronger than cast iron, which may break or pound out in tough applications.

Timken spherical roller bearing solid-block housed units come in five locking configurations: single and double set screws, eccentric locks for reversing applications, tapered-adaptor locks and double-tapered locks.

Choose from three sealing options: labyrinth seals (for high-speed, high-temperature applications) and triple-lip seals made of either nitrile or urethane. Timken® steel auxiliary covers provide an extra layer of protection, and they can be filled with Timken lubricants.

TYPICAL INDUSTRIES AND APPLICATIONS

Use Timken spherical roller bearing solid-block housed units in metals mills, aggregate and cement, mining, power generation, agriculture, pulp, paper, sawmills and other forest industries.





TIMKEN® SAF SPLIT-BLOCK HOUSED UNITS BEAR HEAVY LOADS

Timken® SAF split-block housed units are available in rugged cast iron, ductile iron or cast steel to match a range of industrial environments. Our Timken SAF housed units have separate, matched caps and bases. In larger sizes where housed units are heavier, this split-block design eases installation. Remove the cap using a pry-tool slot for bearing inspection, service and replacement.

Available in a variety of shaft sizes, Timken SAF units offer the choice of tapered-bore design for easy mounting or a straight-bore design for better axial location. The block can be converted from fixed to float by removing the stabilizing ring. Several sealing options protect against contamination, including a standard seal, which is a precision aluminum triple-ring labyrinth seal.

TYPICAL INDUSTRIES AND APPLICATIONS

Use Timken SAF housed bearings in power generation, coal, mining, aggregate, cement, metals, pulp, paper and other forestry operations, water treatment and food processing industries. Applications include warehousing, conveyors, movable bridges/heavy structures, industrial fans and blowers.



HOW TO USE THIS CATALOG

We designed this catalog to help you find the Timken housed units best suited to your specifications.

Timken offers an extensive range of bearings and accessories in both imperial and metric sizes. For your convenience, size ranges are indicated in millimeters and inches. Contact your Timken engineer to learn more about our complete line for the special needs of your application.

This publication contains dimensions, tolerances and load ratings, as well as engineering sections describing fitting practices for shafts and housings, internal clearances, materials and other bearing features. It provides valuable assistance in the initial consideration of the type and characteristics of the bearings that may best suit your particular needs.

ISO and ANSI/ABMA, as used in this publication, refer to the International Organization for Standardization and the American National Standards Institute/American Bearing Manufacturers Association.

Updates are made periodically to this catalog. Visit www.timken.com for the most recent version of the Timken® Housed Unit Catalog.

DISCLAIMER

This catalog is provided solely to give you analysis tools and data to assist you in your product selection. Product performance is affected by many factors beyond the control of Timken. Therefore, you must validate the suitability and feasibility of all product selections for your applications.

Timken products are sold subject to Timken terms and conditions of sale, which include our limited warranty and remedy. You can find these at <http://www.timken.com/en-us/purchase/Pages/TermsandConditionsofSale.aspx>.

Please consult with your Timken engineer for more information and assistance.

Every reasonable effort has been made to ensure the accuracy of the information in this writing, but no liability is accepted for errors, omissions or for any other reason.





SHELF LIFE AND STORAGE OF GREASE-LUBRICATED BEARINGS AND COMPONENTS

To help you get the most value from our products, Timken provides guidelines for the shelf life of grease-lubricated ball and roller bearings, components and assemblies. Shelf life information is based on Timken and industry test data and experience.

SHELF LIFE POLICY

Shelf life should be distinguished from lubricated bearing/component design life as follows:

- Shelf life of the grease-lubricated bearing/component represents the period of time prior to use or installation.
- The shelf life is a portion of the anticipated aggregate design life. It is impossible to accurately predict design life due to variations in lubricant bleed rates, oil migration, operating conditions, installation conditions, temperature, humidity and extended storage.
- Shelf life values, available from Timken, represent a maximum limit and assume adherence to the storage and handling guidelines suggested in this catalog or by a Timken associate. Deviations from the Timken storage and handling guidelines may reduce shelf life. Any specification or operating practice that defines a shorter shelf life should be used.

Timken cannot anticipate the performance of the grease lubricant after the bearing or component is installed or placed in service.

TIMKEN IS NOT RESPONSIBLE FOR THE SHELF LIFE OF ANY BEARING/COMPONENT LUBRICATED BY ANOTHER PARTY.

European REACH Compliance

Timken lubricants, greases and similar products sold in standalone containers or delivery systems are subject to the European REACH (**R**egistration, **E**valuation, **A**uthorization and **R**estriction of **C**hemicals) directive. For import into the European Union, Timken can sell and provide only those lubricants and greases that are registered with ECHA (**E**uropean **C**hemical **A**gency). For further information, please contact your Timken engineer.



STORAGE

Timken suggests the following storage guidelines for our finished products (bearings, components and assemblies, referred to as “products”):

- Unless directed otherwise by Timken, products should be kept in their original packaging until they are ready to be placed into service.
- Do not remove or alter any labels or stencil markings on the packaging.
- Products should be stored in such a way that the packaging is not pierced, crushed or otherwise damaged.
- After a product is removed from its packaging, it should be placed into service as soon as possible.
- When removing a product that is not individually packaged from a bulk pack container, the container should be resealed immediately after the product is removed.
- Do not use product that has exceeded its shelf life as defined in the Timken shelf life guidelines statement.
- The storage area temperature should be maintained between 0° C (32° F) and 40° C (104° F); temperature fluctuations should be minimized.
- The relative humidity should be maintained below 60 percent and the surfaces should be dry.
- The storage area should be kept free from airborne contaminants such as, but not limited to, dust, dirt, harmful vapors, etc.
- The storage area should be isolated from undue vibration.
- Extreme conditions of any kind should be avoided.

Due to the fact that Timken is not familiar with your particular storage conditions, we strongly suggest following these guidelines. However, you may be required by circumstances or applicable government requirements to adhere to stricter storage requirements.





Most bearing components typically ship protected with a corrosion-preventive compound that is not a lubricant. These components may be used in oil-lubricated applications without removal of the corrosion-preventive compound. When using some specialized grease lubrications, we advise you to remove the corrosion-preventive compound before packing the bearing components with suitable grease.

We pre-pack most housed unit types in this catalog with general-purpose grease suitable for their normal applications. It may be necessary for you to frequently replenish the grease for optimum performance.

Be careful in selecting lubrication, however, since different lubricants are often incompatible. You may order housed units pre-lubricated with a specified lubrication.

When you receive a bearing or housed unit shipment, do not remove products from their packaging until they are ready for mounting so they do not become corroded or contaminated.

Store bearings and housed units in an appropriate atmosphere so they remain protected for the intended period.

**WARNING**

Failure to observe the following warnings could create a risk of death or serious injury.

Proper maintenance and handling practices are critical. Failure to follow selection recommendations and installation instructions and to maintain proper lubrication can result in equipment failure.

Overheated bearings can ignite explosive atmospheres. Special care must be taken to properly select, install, maintain, and lubricate housed unit bearings that are used in or near atmospheres that may contain explosive levels of combustible gases or accumulations of dust such as from grain, coal, or other combustible materials. Consult your equipment designer or supplier for installation and maintenance instructions.

**CAUTION**

Failure to follow these cautions could create a risk of injury.

Do not use damaged housed units. The use of a damaged housed unit can result in equipment damage and/or injury.

CAUTION

Failure to follow these cautions may result in property damage.

If hammer and bar are used for installation or removal of a part, use a mild steel bar (e.g., 1010 or 1020 grade). Mild steel bars are less likely to cause release of high-speed fragments from the hammer, bar or the part being removed.

NOTE

Do not use excessive force when mounting or dismantling the unit.

Follow all tolerance, fit, and torque recommendations.

Always follow the Original Equipment Manufacturer's installation and maintenance guidelines.

Ensure proper alignment.

Never weld housed units.

Do not heat components with an open flame.

Do not operate at bearing temperatures above 121° C (250° F).

Warnings for this product line are in this catalog and posted on www.timken.com/en-us/products/warnings/Pages/TimkenHousedUnitWarnings.aspx.



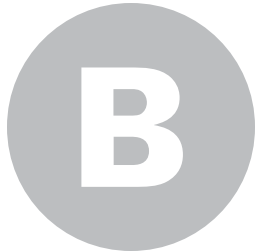

TAPERED ROLLER BEARING TYPE E HOUSED UNITS

Timken® Type E housed units strengthen the performance of your equipment with industry-leading premium tapered roller bearings encased in protective blocks.

Compared to standard bearings, our premium bearings have a 113 percent increase in calculated life and 25 percent more calculated load capacity.

For tough industrial applications, Timken designed a durable housing built with corrosion-resistant electrocoating, locking collars and Timken-designed double-lip seals.

Our seal improves grease retention and our rotating collar acts as an initial flinger. Together, they significantly block contaminant ingress and improve your operations.

Updates are made periodically to this catalog. Visit www.timken.com for the most recent version of the Timken® Housed Unit Catalog.

TYPICAL INDUSTRIES AND APPLICATIONS

Common uses include processing and material handling equipment found in many industries, including pulp and paper, power generation, mining, cement and aggregate. Type E housed units also are widely used in equipment used for air-handling, and water and waste-water treatment. Other common machine applications include mixers, washers, shredders, mills and oven/furnace roller beds.

| | |
|---------------------------------|------|
| Introduction..... | B-2 |
| Engineering..... | B-5 |
| Type E Product Data Tables..... | B-15 |
| Nomenclature..... | B-16 |

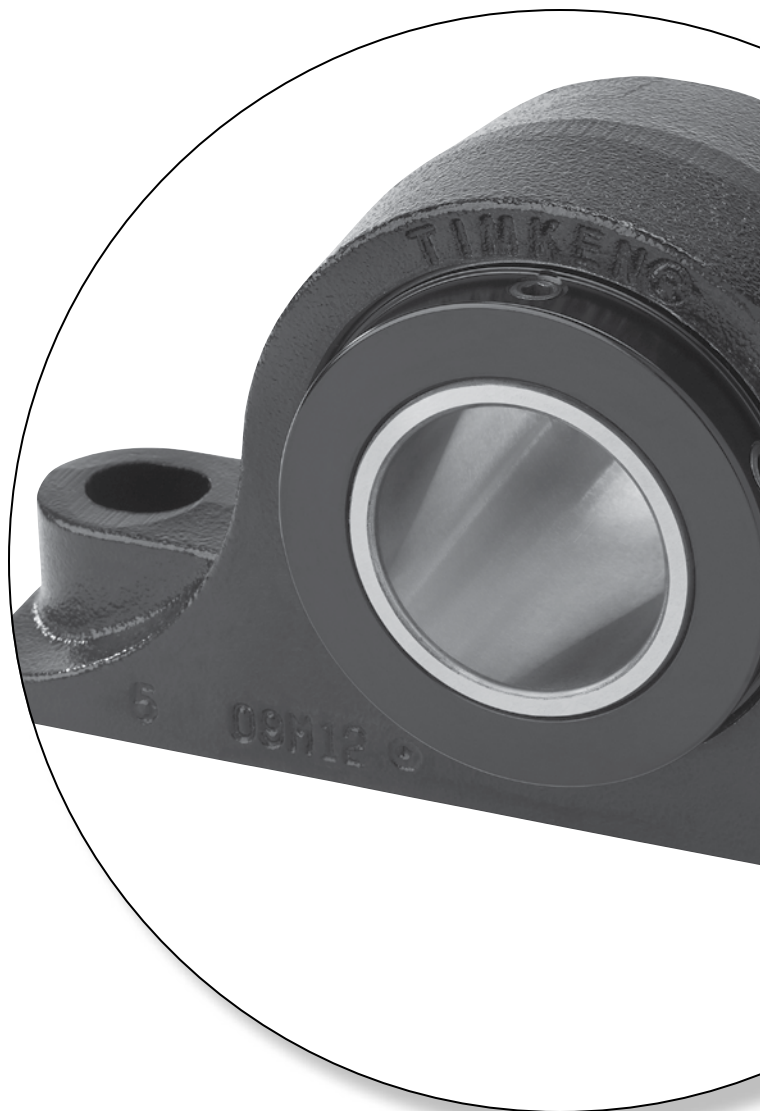

INTRODUCTION

ENHANCED PERFORMANCE BEARINGS, LOWER COST OF OWNERSHIP

Timken Type E tapered roller bearings have a significantly higher load-carrying capability than industry-standard Type E housed units.

Our Type E bearings also experience lower internal contact stresses and frictional drag due to optimized bearing profiles and improved surface textures. This results in improved lubrication performance and up to three times greater misalignment capability than industry-standard tapered roller bearing designs.

Timken-designed double-lip seals help lower maintenance costs. The seals in our Type E housed units optimize lip contact to help improve grease retention and significantly reduce contaminant ingress.

SIZE RANGE AND CONFIGURATION

Timken Type E roller bearing housed units are available in a wide variety of sizes and configurations.

TABLE B-1. SHAFT SIZES AND RANGES

| Housed Unit Configuration | Inches (in.) | Metric (mm) |
|------------------------------|-------------------|-------------|
| Pillow Block: Two-Bolt Base | 1 3/16 thru 3 1/2 | 35 thru 90 |
| Pillow Block: Four-Bolt Base | 2 1/4 thru 5 | 60 thru 125 |
| Flange: Four-Bolt | 1 3/16 thru 4 1/2 | 35 thru 115 |
| Flange: Piloted | 1 3/16 thru 5 | 35 thru 125 |
| Take-Up: Wide Slot | 1 3/8 thru 3 | 35 thru 75 |
| Take-Up: Top Angle | 1 3/4 thru 4 | 45 thru 100 |

European REACH Compliance

Timken lubricants, greases and similar products sold in stand-alone containers or delivery systems are subject to the European REACH (Registration, Evaluation, Authorization and Restriction of CHemicals) directive. For import into the European Union, Timken can sell and provide only those lubricants and greases that are registered with ECHA (European CHemical Agency). For further information, please contact your Timken engineer.

**WARNING**

Failure to observe the following warnings could create a risk of death or serious injury.

Proper maintenance and handling practices are critical. Failure to follow selection recommendations and installation instructions and to maintain proper lubrication can result in equipment failure.

Overheated bearings can ignite explosive atmospheres. Special care must be taken to properly select, install, maintain, and lubricate housed unit bearings that are used in or near atmospheres that may contain explosive levels of combustible gases or accumulations of dust such as from grain, coal, or other combustible materials. Consult your equipment designer or supplier for installation and maintenance instructions.

**CAUTION**

Failure to follow these cautions could create a risk of injury.

Do not use damaged housed units. The use of a damaged housed unit can result in equipment damage and/or injury.

CAUTION

Failure to follow these cautions may result in property damage.

If hammer and bar are used for installation or removal of a part, use a mild steel bar (e.g., 1010 or 1020 grade). Mild steel bars are less likely to cause release of high-speed fragments from the hammer, bar or the part being removed.

NOTE

Do not use excessive force when mounting or dismounting the unit.

Follow all tolerance, fit, and torque recommendations.

Always follow the Original Equipment Manufacturer's installation and maintenance guidelines.

Ensure proper alignment.

Never weld housed units.

Do not heat components with an open flame.

Do not operate at bearing temperatures above 121° C (250° F).

DISCLAIMER

This catalog is provided solely to give you analysis tools and data to assist you in your product selection. Product performance is affected by many factors beyond the control of Timken. Therefore, you must validate the suitability and feasibility of all product selections for your applications.

Timken products are sold subject to Timken terms and conditions of sale, which include our limited warranty and remedy. You can find these at <http://www.timken.com/en-us/purchase/Pages/TermsandConditionsofSale.aspx>.

Please consult with your Timken engineer for more information and assistance.

Every reasonable effort has been made to ensure the accuracy of the information in this writing, but no liability is accepted for errors, omissions or for any other reason.

Updates are made periodically to this catalog. Visit www.timken.com for the most recent version of the Timken® Housed Unit Catalog.

Warnings for this product line are in this catalog and posted on www.timken.com/en-us/products/warnings/Pages/TimkenHousedUnitWarnings.aspx.



BENEFITS AND FEATURES

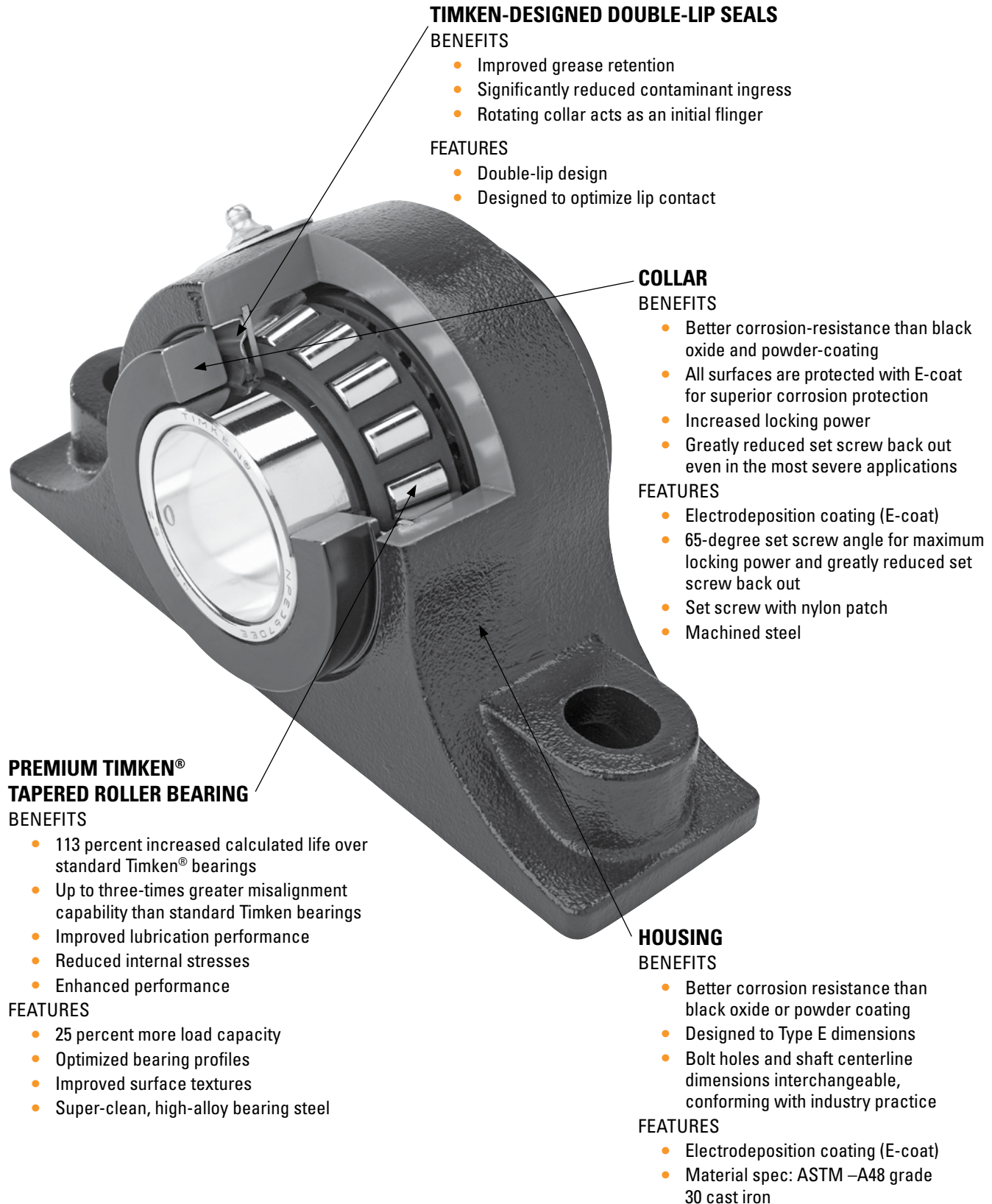

TIMKEN-DESIGNED DOUBLE-LIP SEALS

BENEFITS

- Improved grease retention
- Significantly reduced contaminant ingress
- Rotating collar acts as an initial flinger

FEATURES

- Double-lip design
- Designed to optimize lip contact

COLLAR

BENEFITS

- Better corrosion-resistance than black oxide and powder-coating
- All surfaces are protected with E-coat for superior corrosion protection
- Increased locking power
- Greatly reduced set screw back out even in the most severe applications

FEATURES

- Electrodeposition coating (E-coat)
- 65-degree set screw angle for maximum locking power and greatly reduced set screw back out
- Set screw with nylon patch
- Machined steel

PREMIUM TIMKEN® TAPERED ROLLER BEARING

BENEFITS

- 113 percent increased calculated life over standard Timken® bearings
- Up to three-times greater misalignment capability than standard Timken bearings
- Improved lubrication performance
- Reduced internal stresses
- Enhanced performance

FEATURES

- 25 percent more load capacity
- Optimized bearing profiles
- Improved surface textures
- Super-clean, high-alloy bearing steel

HOUSING

BENEFITS

- Better corrosion resistance than black oxide or powder coating
- Designed to Type E dimensions
- Bolt holes and shaft centerline dimensions interchangeable, conforming with industry practice

FEATURES

- Electrodeposition coating (E-coat)
- Material spec: ASTM –A48 grade 30 cast iron



ENGINEERING

Tapered roller bearings can manage broad ranges of speed and many combinations of radial and thrust loads. Other important environmental conditions affect bearing operation, such as low and high temperature, dust and dirt, moisture and unusual mounting conditions.

This engineering section is not intended to be comprehensive, but does serve as a useful guide when selecting Type E housed units.

To view the complete engineering catalog, please visit www.timken.com. To order the catalog, please contact your Timken engineer and request a copy of the Timken Engineering Manual, order number 10424.

| | |
|---|------|
| Bearing Selection and Life Calculations | B-6 |
| Load and Speed Rating Tables | B-9 |
| Installation and Lubrication | B-12 |



BEARING SELECTION AND LIFE CALCULATIONS

Many different performance criteria exist that dictate how a bearing should be selected. These criteria include bearing fatigue life, rotational precision, power requirements, temperature limits, speed capabilities, sound and more. The life can also be limited by other system components such as the shaft, shaft interface and the housing. This section deals primarily with bearing life as related to material associated fatigue.

BEARING LIFE

Bearing life is defined here as the length of time, or number of revolutions, until a fatigue spall of 6 mm² (0.01 in.²) develops. Since metal fatigue is a statistical phenomenon, the life of an individual bearing is impossible to precisely predetermine. Bearings that may appear to be identical can exhibit considerable life scatter when tested under identical conditions. Thus, it is necessary to base life predictions on a statistical evaluation of a large number of bearings operating under similar conditions. The Weibull distribution function is commonly used to predict the life of a population of bearings at any given reliability level.

RATING LIFE

Rating life, (L₁₀), is the life that 90 percent of a group of apparently identical bearings will complete or exceed before a fatigue spall develops. The L₁₀ life also is associated with 90 percent reliability for a single bearing under a certain load.

BEARING LIFE EQUATIONS

The L₁₀ life has been calculated as follows for bearings under radial or combined loading where the dynamic equivalent radial load, (P_r), has been determined.

Tapered roller bearings often use a dynamic load rating (C₉₀) based on 90 million cycles, yielding the equations as follows:

$$L_{10} = \left(\frac{C_{90}}{P_r} \right)^{10/3} (90 \times 10^6) \text{ revolutions}$$

or based on shaft speed, (RPM),

$$L_{10} = \left(\frac{C_{90}}{P_r} \right)^{10/3} \left(\frac{90 \times 10^6}{60n} \right) \text{ hours}$$

Timken has expanded standard life equations to include certain additional variables that can affect bearing performance. The approach that considers these factors in bearing analysis and selection has been termed Bearing Systems Analysis (BSA).

The Timken expanded bearing life equation for tapered roller bearings is:

$$L_{na} = a_1 a_2 a_{3d} a_{3k} a_{3l} a_{3m} a_{3p} \left(\frac{C_{90}}{P_r} \right)^{10/3} \left(\frac{90 \times 10^6}{60n} \right) \text{ hours}$$

Where,

- a₁ = Reliability life factor
- a₂ = Material life factor
- a_{3d} = Debris life factor
- a_{3k} = Load zone life factor
- a_{3l} = Lubrication life factor
- a_{3m} = Misalignment life factor
- a_{3p} = Low-load life factor

More details on Life Adjustment Factors can be found in the Timken Engineering Manual (order no. 10424) available on timken.com or by contacting a Timken engineer.

Other factors that can be taken into account within the simple bearing life equation are shock or vibration. These are known to occur in many industrial applications due to combined factors including imbalanced dynamic forces, abusive handling, equipment misuse or neglect. These are difficult to predict.

When these conditions are known or suspected to occur, we suggest that equipment designers use a multiplication factor of (1.5 x P_r) to estimate effects on housed unit selection and system reliability. Performance testing or advanced analysis is strongly suggested to validate final product selection.

TIMKEN® ROLLER HOUSED UNIT SELECTION

The double extended tapered roller bearings used in the Type E roller housed units are suited for carrying radial, thrust or a combination of both types of loading. This section will describe the bearing selection process using different methods based on selection criteria and application details.

METHOD 1 – SELECTION TABLE (RADIAL LOADS ONLY)

Note: Based on reference conditions with adequate lubrication.

- Determine criteria for bearing selection:
 - L_{10} life required.
 - Size of bearing based on shaft size (if known).
 - Loading conditions (radial) of the application.
 - Shaft speed measured by revolutions per minute (RPM).
- Use table B-3:
 - Find speed criteria on upper row.
 - Proceed in the column directly below that speed to the equivalent radial load (P_r) that is equal to or greater than that required.
 - Follow that row to the left to determine what the minimum shaft size should be for the required L_{10} life (hours). Many values are listed to help in selecting the proper bearing.

METHOD 2 – USING BEARING LIFE EQUATION TO SELECT BEARING FOR A DIFFERENT L_{10} LIFE (RADIAL LOADS ONLY)

If a different life is required than what is found in table B-3, it can be calculated from the bearing life equation. Note that each value in the selection table was calculated using this equation. The equation can be rewritten based on the unknown value.

Take the bearing life equation shown previously:

$$L_{10} = \left(\frac{C_{90}}{P_r} \right)^{10/3} \left(\frac{90 \times 10^6}{60n} \right) \text{ hours}$$

Or rewritten as:

$$L_{10} = \left(\frac{C_{90}}{P_r} \right)^{10/3} \left(\frac{1500000}{n} \right) \text{ hours}$$

Solve for C_{90} :

$$C_{90} = \left(\frac{L_{10} \times n}{1500000} \right)^{0.3} \left(P_r \right)$$

After calculating the C_{90} , check table B-3 to determine the shaft size needed. (Note: Ensure that the application speed does not exceed the maximum RPM found on that same table). Check the radial load, as well, with regard to the maximum allowable slip-fit radial load (F_{r-max} , see table B-5). If this value is exceeded, then a tighter line-to-line or press fit is required.

TIMKEN METHOD 3A – DETERMINE EQUIVALENT RADIAL LOADS AND USE BEARING LIFE EQUATION (FOR COMBINED RADIAL- AND THRUST-LOADED APPLICATIONS)

For combined radial- and thrust-loaded applications, it is necessary to calculate an equivalent dynamic radial bearing load, designated by P_r , before applying the L_{10} bearing life equation. The dynamic equivalent radial load is defined as a single radial load that, if applied to the bearing, will result in the same life as the combined loading under which the bearing operates.

Tapered roller bearings are ideally suited to carrying all types of loads – radial, thrust and any combination of both. Due to the tapered design of the bearing, a radial load will induce a thrust reaction that must be opposed by an equal or greater thrust load to keep the bearing cone and cup from separating.

The ratio of the radial to the thrust load and the bearing included cup angle determine the load zone in a given bearing and the number of rollers in contact in the load zone in the bearing. If all the rollers are in contact, the load zone is referred to as being 360 degrees. When only radial load is applied to a tapered roller bearing – for convenience it is assumed in using the traditional calculation method that half the rollers support the load – the load zone is 180 degrees.

For Type E roller housed units with no external thrust load ($F_a = 0$), the dynamic equivalent radial load (P_r) equals F_r . This P_r value can then be used in the bearing life equation shown on page B-6.

For Type E units with thrust loading, table B-2 can be used. In this table, only bearing A has an applied thrust load. If bearing B has the applied thrust load, each A in the equations should be replaced by a B and vice versa.

The equations in the first row of table B-2 yield single-row equivalent radial loads (P_{rA} and P_{rB}). To find the two-row (Type E housed unit) life, the following equations must be used to solve for L_{10} life of each bearing row, and then combined for the system unit life:

$$L_{10A} = \left(\frac{C_{90}}{1.74 \times P_{rA}} \right)^{10/3} \left(\frac{1500000}{n} \right) \text{ hours}$$

and,

$$L_{10B} = \left(\frac{C_{90}}{1.74 \times P_{rB}} \right)^{10/3} \left(\frac{1500000}{n} \right) \text{ hours}$$

then,

$$L_{10} = \left[\left(\frac{1}{L_{10A}} \right)^{3/2} + \left(\frac{1}{L_{10B}} \right)^{3/2} \right]^{-2/3} \text{ hours}$$

In the second row of table B-2, $P_{rB} = 0$; therefore, $P_{rA} = P_r$ in the standard bearing life equation shown on page B-6.

ISO METHOD 3B

The ISO Method uses the following equation to determine the equivalent dynamic radial load:

$$P_r = XF_r + YF_a$$

Where,

P_r = Dynamic equivalent radial load

F_r = Applied radial load

F_a = Applied axial load

X = Radial load factor

Y = Axial load factor

The values for X and Y are found in table B-5. In order to find these values, the value of F_r/F_a must be compared to the e value. Determine if the value is greater than or less than the e and then use the corresponding X and Y values below that formula.

After the P_r value is calculated, then use the bearing life equation as shown on page B-6.

ISO METHOD 4 – (THRUST ONLY APPLICATIONS)

Use the equation $P_r = YF_a$. Use Y from table B-5 (for $F_a/F_r > e$). Then use this P_r value for the equivalent radial load in the bearing life equation. This value can also be used as the radial load in the load rating selection table B-3.

After selection has been made, verify that the application does not exceed the maximum allowable speed, allowable thrust loads and allowable housing loads. Heavy loads should be directed through the base of the units. See table B-4 for housing ratings for loads applied upward through the top of the housed unit perpendicular to the shaft axis. The housings need to be bolted down with adequate strength.

TABLE B-2. DYNAMIC EQUIVALENT RADIAL LOAD CALCULATIONS

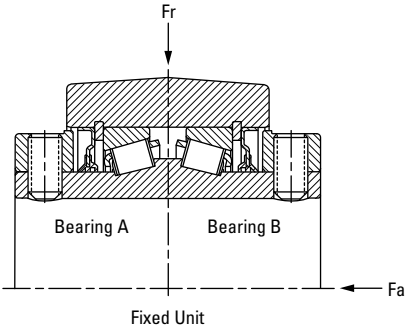
| Design | Thrust Condition | Dynamic Equivalent Radial Load |
|---|------------------------------|--|
|  | $F_a \leq \frac{0.6 F_r}{K}$ | $P_{rA} = 0.5 F_r + 0.83 K F_a$ $P_{rB} = 0.5 F_r - 0.83 K F_a$ |
| | $F_a > \frac{0.6 F_r}{K}$ | $P_{rA} = 0.4 F_r + K F_a$ $P_{rB} = 0$ |

LOAD AND SPEED RATING TABLES

The table below shows the allowable equivalent radial load for a given shaft size, speed, and L_{10} life under normal operating conditions with adequate lubrication. Refer to the discussion on the previous pages of this catalog to determine the criteria for combinations not shown in this table or for combined load applications.

NOTE

The shaded area in this table indicates radial loads that exceed the maximum allowable slip-fit radial load (F_{r-max}). Operation at these conditions may require line-to-line (g6 or h6) or light press fit (m6) on the shaft.

TABLE B-3. TYPE E TAPERED ROLLER BEARING LOAD RATING SELECTION TABLE

| Shaft Dia. | Basic Dynamic Load Rating C_{90} | Max Speed Timken Double-Lip Seal RPM | Life L_{10} hrs. | Equivalent Radial Loads Allowed, P_r at Various Speeds, RPM | | | | | | | | | | | | | | | | | | |
|---|------------------------------------|--------------------------------------|--------------------|---|-------|-------|-------|-------|-------|-------|-------|-------|------|------|------|------|------|------|------|------|------|------|
| | | | | 50 | 100 | 150 | 250 | 500 | 750 | 1000 | 1200 | 1360 | 1530 | 1640 | 1750 | 2060 | 2420 | 2730 | 3050 | 3320 | 3820 | 4490 |
| in. mm | lbs. | RPM | hrs. | lbs. | lbs. | lbs. | lbs. | lbs. | lbs. | lbs. | lbs. | lbs. | lbs. | lbs. | lbs. | lbs. | lbs. | lbs. | lbs. | lbs. | lbs. | |
| 1 3/16 1 1/4 | 3810 | 4490 | 10000 | 5297 | 4303 | 3810 | 3269 | 2655 | 2351 | 2157 | 2042 | 1966 | 1898 | 1859 | 1823 | 1736 | 1654 | 1596 | 1543 | 1505 | 1443 | 1374 |
| | | | 30000 | 3810 | 3095 | 2740 | 2351 | 1910 | 1691 | 1551 | 1468 | 1414 | 1365 | 1337 | 1311 | 1249 | 1190 | 1148 | 1110 | 1082 | 1038 | 988 |
| | | | 40000 | 3495 | 2839 | 2514 | 2157 | 1752 | 1551 | 1423 | 1347 | 1297 | 1252 | 1227 | 1203 | 1145 | 1091 | 1053 | 1018 | 993 | 952 | 907 |
| | | | 60000 | 3095 | 2514 | 2226 | 1910 | 1551 | 1373 | 1260 | 1193 | 1149 | 1109 | 1086 | 1065 | 1014 | 966 | 932 | 902 | 879 | 843 | 803 |
| | | | 100000 | 2655 | 2157 | 1910 | 1638 | 1331 | 1178 | 1081 | 1023 | 986 | 951 | 932 | 914 | 870 | 829 | 800 | 774 | 754 | 723 | 689 |
| 1 3/8 1 7/16 35 mm | 6100 | 3820 | 10000 | 8481 | 6889 | 6100 | 5233 | 4251 | 3764 | 3453 | 3269 | 3148 | 3039 | 2976 | 2919 | 2780 | 2649 | 2555 | 2471 | 2409 | 2310 | |
| | | | 30000 | 6100 | 4955 | 4387 | 3764 | 3057 | 2707 | 2483 | 2351 | 2264 | 2186 | 2141 | 2099 | 1999 | 1905 | 1837 | 1777 | 1733 | 1661 | |
| | | | 40000 | 5596 | 4545 | 4024 | 3453 | 2804 | 2483 | 2278 | 2157 | 2077 | 2005 | 1964 | 1926 | 1834 | 1747 | 1685 | 1630 | 1589 | 1524 | |
| | | | 60000 | 4955 | 4024 | 3564 | 3057 | 2483 | 2199 | 2017 | 1910 | 1839 | 1775 | 1739 | 1705 | 1624 | 1547 | 1492 | 1444 | 1407 | 1349 | |
| | | | 100000 | 4251 | 3453 | 3057 | 2623 | 2130 | 1886 | 1730 | 1638 | 1578 | 1523 | 1492 | 1463 | 1393 | 1327 | 1280 | 1238 | 1207 | 1158 | |
| 1 1/2 1 5/8 1 11/16 40 mm | 7860 | 3320 | 10000 | 10928 | 8877 | 7860 | 6743 | 5477 | 4850 | 4449 | 4212 | 4057 | 3916 | 3835 | 3761 | 3582 | 3413 | 3292 | 3184 | 3104 | | |
| | | | 30000 | 7860 | 6384 | 5653 | 4850 | 3939 | 3488 | 3200 | 3029 | 2918 | 2816 | 2758 | 2705 | 2576 | 2455 | 2367 | 2290 | 2232 | | |
| | | | 40000 | 7210 | 5856 | 5186 | 4449 | 3614 | 3200 | 2935 | 2779 | 2677 | 2584 | 2530 | 2482 | 2363 | 2252 | 2172 | 2101 | 2048 | | |
| | | | 60000 | 6384 | 5186 | 4592 | 3939 | 3200 | 2833 | 2599 | 2461 | 2370 | 2288 | 2241 | 2197 | 2092 | 1994 | 1923 | 1860 | 1813 | | |
| | | | 100000 | 5477 | 4449 | 3939 | 3380 | 2745 | 2431 | 2230 | 2111 | 2033 | 1963 | 1922 | 1885 | 1795 | 1710 | 1650 | 1596 | 1556 | | |
| 1 3/4 1 7/8 1 15/16 2 45 mm 50 mm | 10300 | 3050 | 10000 | 14321 | 11632 | 10300 | 8837 | 7178 | 6355 | 5830 | 5520 | 5316 | 5132 | 5026 | 4929 | 4694 | 4472 | 4313 | 4172 | | | |
| | | | 30000 | 10300 | 8366 | 7408 | 6355 | 5162 | 4571 | 4193 | 3970 | 3824 | 3691 | 3615 | 3545 | 3376 | 3217 | 3102 | 3001 | | | |
| | | | 40000 | 9448 | 7674 | 6795 | 5830 | 4735 | 4193 | 3846 | 3642 | 3507 | 3386 | 3316 | 3252 | 3097 | 2951 | 2846 | 2753 | | | |
| | | | 60000 | 8366 | 6795 | 6017 | 5162 | 4193 | 3713 | 3406 | 3225 | 3106 | 2998 | 2936 | 2879 | 2742 | 2613 | 2520 | 2437 | | | |
| | | | 100000 | 7178 | 5830 | 5162 | 4429 | 3597 | 3185 | 2922 | 2766 | 2664 | 2572 | 2519 | 2470 | 2352 | 2241 | 2162 | 2091 | | | |
| 2 3/16 55 mm | 10900 | 2730 | 10000 | 15155 | 12310 | 10900 | 9351 | 7596 | 6726 | 6170 | 5841 | 5626 | 5431 | 5319 | 5216 | 4967 | 4733 | 4565 | | | | |
| | | | 30000 | 10900 | 8854 | 7840 | 6726 | 5463 | 4837 | 4437 | 4201 | 4046 | 3906 | 3825 | 3752 | 3572 | 3404 | 3283 | | | | |
| | | | 40000 | 9999 | 8121 | 7191 | 6170 | 5011 | 4437 | 4070 | 3854 | 3712 | 3583 | 3509 | 3441 | 3277 | 3122 | 3012 | | | | |
| | | | 60000 | 8854 | 7191 | 6368 | 5463 | 4437 | 3929 | 3604 | 3412 | 3287 | 3172 | 3107 | 3047 | 2902 | 2765 | 2667 | | | | |
| | | | 100000 | 7596 | 6170 | 5463 | 4687 | 3807 | 3371 | 3092 | 2928 | 2820 | 2722 | 2666 | 2614 | 2489 | 2372 | 2288 | | | | |
| 2 1/4 2 7/16 2 1/2 60 mm 65 mm | 11600 | 2420 | 10000 | 16129 | 13100 | 11600 | 9952 | 8083 | 7158 | 6566 | 6216 | 5987 | 5779 | 5660 | 5551 | 5286 | 5037 | | | | | |
| | | | 30000 | 11600 | 9422 | 8343 | 7158 | 5814 | 5148 | 4722 | 4471 | 4306 | 4157 | 4071 | 3992 | 3802 | 3622 | | | | | |
| | | | 40000 | 10641 | 8643 | 7653 | 6566 | 5333 | 4722 | 4332 | 4101 | 3950 | 3813 | 3734 | 3662 | 3487 | 3323 | | | | | |
| | | | 60000 | 9422 | 7653 | 6777 | 5814 | 4722 | 4181 | 3836 | 3631 | 3498 | 3376 | 3307 | 3243 | 3088 | 2942 | | | | | |
| | | | 100000 | 8083 | 6566 | 5814 | 4988 | 4051 | 3587 | 3291 | 3116 | 3001 | 2897 | 2837 | 2782 | 2649 | 2524 | | | | | |
| 2 11/16 2 3/4 2 15/16 3 70 75 | 12300 | 2060 | 10000 | 17102 | 13891 | 12300 | 10552 | 8571 | 7590 | 6962 | 6591 | 6348 | 6128 | 6002 | 5886 | 5605 | | | | | | |
| | | | 30000 | 12300 | 9991 | 8846 | 7590 | 6165 | 5459 | 5007 | 4741 | 4566 | 4407 | 4317 | 4233 | 4031 | | | | | | |
| | | | 40000 | 11283 | 9165 | 8115 | 6962 | 5655 | 5007 | 4593 | 4349 | 4188 | 4043 | 3960 | 3883 | 3698 | | | | | | |
| | | | 60000 | 9991 | 8115 | 7186 | 6165 | 5007 | 4434 | 4067 | 3851 | 3709 | 3580 | 3506 | 3439 | 3274 | | | | | | |
| | | | 100000 | 8571 | 6962 | 6165 | 5289 | 4296 | 3804 | 3489 | 3304 | 3182 | 3071 | 3008 | 2950 | 2809 | | | | | | |
| 3 3/16 3 1/4 3 7/16 3 1/2 80 mm 85 mm 90 mm | 19600 | 1640 | 10000 | 27252 | 22135 | 19600 | 16815 | 13658 | 12094 | 11094 | 10503 | 10116 | 9765 | 9564 | | | | | | | | |
| | | | 30000 | 19600 | 15920 | 14097 | 12094 | 9823 | 8698 | 7979 | 7554 | 7276 | 7023 | 6879 | | | | | | | | |
| | | | 40000 | 17979 | 14604 | 12931 | 11094 | 9011 | 7979 | 7319 | 6930 | 6674 | 6443 | 6310 | | | | | | | | |
| | | | 60000 | 15920 | 12931 | 11450 | 9823 | 7979 | 7065 | 6481 | 6136 | 5910 | 5705 | 5587 | | | | | | | | |
| | | | 100000 | 13658 | 11094 | 9823 | 8428 | 6845 | 6061 | 5560 | 5264 | 5070 | 4894 | 4793 | | | | | | | | |

Continued on next page.

LOAD AND SPEED RATING TABLES – continued

TABLE B-3. TYPE E TAPERED ROLLER BEARING LOAD RATING SELECTION TABLE – Continued from previous page.

| Shaft Dia. | Basic Dynamic Load Rating C ₉₀ | Max Speed Timken Double-Lip Seal RPM | Life L ₁₀ | Equivalent Radial Loads Allowed, P, at Various Speeds, RPM | | | | | | | | | | | | | | | | | | | | |
|-------------------------------------|--|---|-------------------------|--|-------|-------|-------|-------|-------|-------|-------|-------|-------|------|------|------|------|------|------|------|------|------|--|--|
| | | | | 50 | 100 | 150 | 250 | 500 | 750 | 1000 | 1200 | 1360 | 1530 | 1640 | 1750 | 2060 | 2420 | 2730 | 3050 | 3320 | 3820 | 4490 | | |
| in. mm | lbs. | RPM | hrs. | lbs. | lbs. | lbs. | lbs. | lbs. | lbs. | lbs. | lbs. | lbs. | lbs. | lbs. | lbs. | lbs. | lbs. | lbs. | lbs. | lbs. | lbs. | | | |
| 3 15/16 4 100 mm | 26900 | 1530 | 10000 | 37401 | 30379 | 26900 | 23078 | 18745 | 16598 | 15226 | 14415 | 13884 | 13402 | | | | | | | | | | | |
| | | | 30000 | 26900 | 21850 | 19347 | 16598 | 13482 | 11938 | 10951 | 10368 | 9986 | 9639 | | | | | | | | | | | |
| | | | 40000 | 24676 | 20043 | 17747 | 15226 | 12367 | 10951 | 10045 | 9511 | 9160 | 8842 | | | | | | | | | | | |
| | | | 60000 | 21850 | 17747 | 15715 | 13482 | 10951 | 9697 | 8895 | 8421 | 8111 | 7829 | | | | | | | | | | | |
| | | | 100000 | 18745 | 15226 | 13482 | 11566 | 9395 | 8319 | 7631 | 7225 | 6959 | 6717 | | | | | | | | | | | |
| 4 7/16 4 1/2 110 mm 115 mm | 33000 | 1360 | 10000 | 45883 | 37268 | 33000 | 28311 | 22996 | 20362 | 18678 | 17684 | 17033 | | | | | | | | | | | | |
| | | | 30000 | 33000 | 26804 | 23734 | 20362 | 16539 | 14645 | 13434 | 12719 | 12250 | | | | | | | | | | | | |
| | | | 40000 | 30271 | 24588 | 21772 | 18678 | 15172 | 13434 | 12323 | 11667 | 11237 | | | | | | | | | | | | |
| | | | 60000 | 26804 | 21772 | 19278 | 16539 | 13434 | 11895 | 10912 | 10331 | 9950 | | | | | | | | | | | | |
| | | | 100000 | 22996 | 18678 | 16539 | 14189 | 11525 | 10205 | 9361 | 8863 | 8536 | | | | | | | | | | | | |
| 4 15/16 5 125 mm | 45500 | 1200 | 10000 | 63263 | 51385 | 45500 | 39035 | 31706 | 28075 | 25754 | 24383 | | | | | | | | | | | | | |
| | | | 30000 | 45500 | 36957 | 32725 | 28075 | 22804 | 20192 | 18523 | 17537 | | | | | | | | | | | | | |
| | | | 40000 | 41738 | 33902 | 30019 | 25754 | 20918 | 18523 | 16991 | 16087 | | | | | | | | | | | | | |
| | | | 60000 | 36957 | 30019 | 26581 | 22804 | 18523 | 16401 | 15045 | 14244 | | | | | | | | | | | | | |
| | | | 100000 | 31706 | 25754 | 22804 | 19564 | 15891 | 14071 | 12907 | 12220 | | | | | | | | | | | | | |

HOUSING RATINGS

TABLE B-4. HOUSING RATINGS – TYPE E PILLOW BLOCKS: TWO-BOLT BASE, FOUR-BOLT BASE

| Shaft Dia. | Maximum Housing Rating Gray Iron at 180° |
|-----------------------------------|---|
| in. mm | lbs. |
| 1 3/16 thru 1 1/4 | 1600 |
| 1 3/8 thru 1 7/16 35 | 3150 |
| 1 1/2 thru 1 11/16 40 | 3000 |
| 1 3/4 thru 2 45 thru 50 | 5150 |
| 2 3/16 55 | 3500 |
| 2 1/4 thru 2 1/2 60 thru 65 | 6550 |
| 2 11/16 thru 3 70 thru 75 | 7000 |
| 3 3/16 thru 3 1/2 80 thru 90 | 15700 |
| 3 15/16 thru 4 100 | 16250 |
| 4 7/16 thru 4 1/2 110 thru 115 | 21000 |
| 4 15/16 thru 5 125 | 22860 |

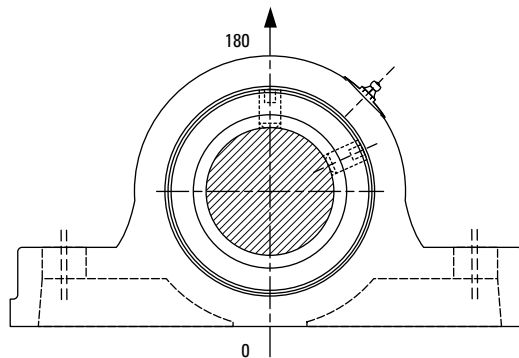

1. These ratings have been calculated for initial bearing selection. These include a nominal safety factor for the standard Type E two- and four-bolt pillow blocks. The following conditions apply: standard cast-iron material, the force is applied perpendicular to the shaft axis, and the housing bolts are properly clamped.
2. These limits should not be applied to operating conditions that include impact (shock) loads or combined radial and thrust loads that are not directed into the pillow block base.
3. If heavy cap loads are expected, use the following modifications to mounting method or equipment design: Grade 8 base bolts and hardened washers; ensure that proper installation torque is achieved and is uniform.
4. If axial loads are expected, provide mechanical stops or shear bars with strength sufficient to support the load. Specification of the strength, material, method of fastening, and precision location are the responsibility of the machinery designer.

TABLE B-5. TAPERED ROLLER BEARING – RADIAL AND THRUST FACTORS; SPEED AND SLIP-FIT LOAD LIMITS

| Shaft Dia. | $F_a / F_r \leq e$ | | $F_a / F_r > e$ | | K Factor | Dynamic Load Rating ⁽¹⁾ C_{90} | Static Load Rating C_0 | Maximum Permissible Thrust Load ⁽²⁾ F_{a-max} | Max Speed ⁽³⁾ RPM | Maximum Allowable Slip-Fit Radial Load ⁽⁴⁾ F_{r-max} | |
|---|--------------------|------|-----------------|------|----------|--|-----------------------------|---|---------------------------------|--|-------|
| | e | X | Y | X | | | | | | | Y |
| in. mm | | | | | | lbs. | lbs. | lbs. | | lbs. | |
| 1 3/16 1 1/4 | 0.49 | 0.87 | 1.77 | 0.70 | 2.14 | 1.23 | 3810 | 15760 | 2000 | 4490 | 3100 |
| 1 3/8 1 7/16 35 mm | 0.46 | 0.87 | 1.89 | 0.70 | 2.28 | 1.31 | 6100 | 26000 | 2590 | 3820 | 5000 |
| 1 1/2 1 5/8 1 11/16 40 mm | 0.44 | 0.87 | 1.96 | 0.70 | 2.37 | 1.36 | 7860 | 33000 | 2590 | 3320 | 6400 |
| 1 3/4 1 7/8 1 15/16 2 45 mm 50 mm | 0.33 | 0.87 | 2.64 | 0.70 | 3.18 | 1.83 | 10300 | 43000 | 2590 | 3050 | 8400 |
| 2 3/16 55 mm | 0.36 | 0.87 | 2.38 | 0.70 | 2.87 | 1.65 | 10900 | 48200 | 3454 | 2730 | 8900 |
| 2 1/4 2 7/16 2 1/2 60 mm 65 mm | 0.4 | 0.87 | 2.17 | 0.70 | 2.63 | 1.51 | 11600 | 54000 | 3454 | 2420 | 9500 |
| 2 11/16 2 3/4 2 15/16 3 70 mm 75 mm | 0.46 | 0.87 | 1.87 | 0.70 | 2.26 | 1.3 | 12300 | 61200 | 5181 | 2060 | 10000 |
| 3 3/16 3 1/4 3 7/16 3 1/2 80 mm 85 mm 90 mm | 0.5 | 0.87 | 1.71 | 0.70 | 2.07 | 1.19 | 19600 | 108600 | 5181 | 1640 | 16000 |
| 3 15/16 4 100 mm | 0.49 | 0.87 | 1.77 | 0.70 | 2.14 | 1.23 | 26900 | 154000 | 6908 | 1530 | 22000 |
| 4 7/16 4 1/2 110 mm | 0.53 | 0.87 | 1.63 | 0.70 | 1.97 | 1.13 | 33000 | 188400 | 6908 | 1360 | 27000 |
| 4 15/16 5 125 mm | 0.47 | 0.87 | 1.83 | 0.70 | 2.21 | 1.27 | 45500 | 266000 | 6908 | 1200 | 35000 |

⁽¹⁾ C_{90} is the dynamic load rating based on a rated life of 90 million revolutions (3000 hrs. at 500 RPM).

⁽²⁾ F_{a-max} is based on the limits of the holding force of two properly tightened collars and set screws. When a single collar is installed, 50 percent of the values should be used.

⁽³⁾Double-lip seal.

⁽⁴⁾Operating at conditions where loads approach or exceed F_{r-max} may require line-to-line (g6 or h6) or light press-fit (m6) on the shaft.

NOTE: The maximum permissible thrust load applies to conditions of slip-fit with set screw mounting or in applications where a large moment loading occurs. The values shown are valid only when two collars and set screws are used.

NOTE: When heavy thrust forces are applied, the friction between the pillow block and base may not be sufficient to prevent movement. Mechanical stops or shear bars with strength sufficient to support the load should be added. Never weld the pillow block or bearing to secure it to the shaft or base.

INSTALLATION AND LUBRICATION

INSTALLATION

Proper installation of the housed unit is necessary. This includes the use of shafts that are clean, free from nicks and burrs, straight and of proper diameter. Follow table B-6. The recommended shaft tolerances shown in table B-6 are for normal loaded applications. Refer to table B-5 to verify the maximum allowable slip-fit radial load (F_{r-max}) and to determine if a tighter fit is required.

Do not mount the bearing on a worn section of the shaft. Use of shafts with hardness greater than HRC 45 will reduce the effectiveness of locking devices.

Also, it is necessary that the housed units and shafts are in alignment (fig. B-3). Verify that the mounting surfaces are in the same flat plane to help make sure good alignment is achieved. If shimming is required to minimize misalignment, use full shims across the entire housing base (fig. B-4). The bolts then need to be alternately torqued securely to their mounting supports.

Flat washers should be used when installing any kind of housed unit (fig. B-4). Washers should be properly sized to the bolt diameter. Typically, the diameters of SAE washers are too small to properly cover the bolt slots on the units. After the locking collars are lined up flush with the end of the cone (inner ring) face (fig. B-5), set screws then need to be properly tightened per table B-7. Set screws in multiple units should be aligned to each other (fig. B-6).

LUBRICATION

To help maintain a rolling bearing's antifriction characteristics, lubrication is needed to:

- Minimize rolling resistance due to deformation of the rolling elements and raceway under load by separating the mating surfaces.
- Minimize sliding friction occurring between rolling elements, raceways and cage.
- Protect from corrosion and, with grease lubrication, from contaminant ingress.

Bearings have been factory prelubricated with Timken Premium All Purpose Industrial Grease, which is an NLGI No. 2 lithium-complex-based grease. This is suitable for normal operating conditions. Units should be relubricated with the Timken grease or one that is compatible and made for roller bearings.

It is vital that the greases used are compatible. Please consult with a Timken engineer for the grease specifications if the use of a grease other than the Timken grease mentioned above is needed.

Normal service is considered as operation in a clean, dry environment at temperatures between -34°C to $+82^{\circ}\text{C}$ (-30°F and $+180^{\circ}\text{F}$). If service is beyond normal conditions due to speed, temperature or exposure to moisture, dirt or corrosive chemicals, periodic relubrication may be advisable. For extreme conditions or conditions in which special chemicals are used, consult your Timken engineer.

After extended storage or periods when the unit is not in operation, fresh grease should be added.

For units operating in dirty or wet environments, the bearing should contain as much grease as possible, based on the shaft speed, to help protect against contamination. For slower applications, with shaft speeds typically less than 200 RPM, the unit should have additional grease added at start-up to fill the bearing.

Lubrication affects the bearing operating temperature as well. If the bearing does not have enough grease, this could lead to higher temperature operation due to inadequate lubrication film thickness. Excessive grease will lead to higher operating temperatures due to grease churning. This can cause bearing overheating. To avoid this, it may be necessary to remove some of the grease inside the unit. The grease fitting may be removed briefly in this circumstance to allow excess grease to purge. The grease fitting must be put back in place. It is best to observe the bearing and its temperature to adjust the lubrication as needed.

RELUBRICATION CYCLE

Adequate lubrication is an essential element affecting the bearing life. The two primary considerations that determine the relubrication cycle on any application are operating temperature and contamination. Every attempt should be made to maintain seals at peak efficiency.

The higher the temperature, the more rapidly the grease oxidizes. Grease life is reduced by approximately half for every 10°C (18°F) rise in temperature. The higher the operating temperature, the more often the grease must be replenished. Table B-8 can be used as a suggested initial point of reference. Relubrication frequency and quantity intervals are best developed through experience for each application based on types of service, which may differ from the suggestions in table B-8.

When the bearing is not in operation for an extended period of time, grease should be added to prevent corrosion.

Table B-8 shows general lubrication suggested starting points only. Please read the entire installation instructions prior to using these tables. Applications should be regularly reviewed and lubrication amounts and intervals modified as needed to assure best results.

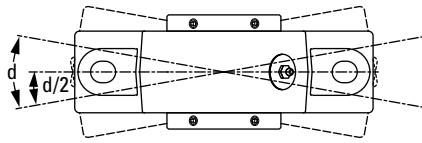

ALIGN HOUSING TO 1/2 TOTAL ANGULAR MOVEMENT.

Fig. B-3.

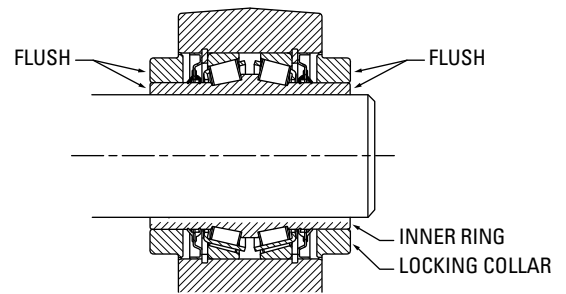

LINE UP COLLARS WITH INNER RING.

Fig. B-5.

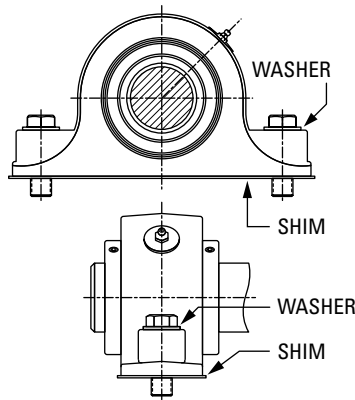

USE WASHERS AND FULL SHIMS.

Fig. B-4.

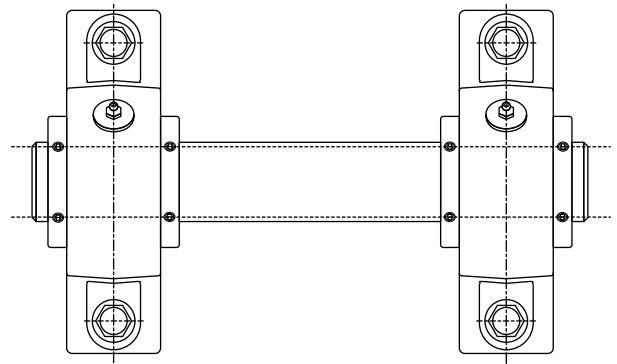

LINE UP SET SCREWS IN MULTIPLE UNITS.

Fig. B-6.

TABLE B-6. RECOMMENDED SHAFT TOLERANCE

| Shaft Dia. | Tolerance |
|----------------------------------|---|
| in. mm | in. mm |
| Up thru 1 1/2 35 mm | +0.0000 to -0.0005 +0.000 to -0.013 |
| 1 5/8 thru 4 40 thru 100 mm | +0.0000 to -0.0010 +0.000 to -0.025 |
| 4 7/16 thru 5 110 thru 125 mm | +0.0000 to -0.0015 +0.000 to -0.038 |

NOTE: Refer to the Timken Engineering Manual (order no. 10424) for ISO g6, h6 or m6 shaft tolerance data.

TABLE B-7. RECOMMENDED SET SCREW TIGHTENING TORQUE

| Shaft Dia. | Set Screw Size | Tightening Torque |
|--------------------------------------|----------------|-------------------|
| in. mm | in. | in. - lbs. |
| 1 3/16 thru 1 11/16 35 thru 40 mm | 5/16-18 | 155 |
| 1 3/4 thru 2 1/2 45 thru 65 mm | 3/8-16 | 275 |
| 2 11/16 thru 3 1/2 70 thru 90 mm | 1/2-13 | 615 |
| 3 15/16 thru 5 100 thru 125 mm | 5/8-11 | 1315 |



WARNING

Failure to observe the following warnings could create a risk of death or serious injury.

Overheated bearings can ignite explosive atmospheres. Special care must be taken to properly select, install, maintain, and lubricate housed unit bearings that are used in or near atmospheres that may contain explosive levels of combustible gases or accumulations of dust such from grain, coal, or other combustible materials. Consult your equipment designer or supplier for installation and maintenance instructions.

TABLE B-8. SUGGESTED RELUBRICATION INTERVALS (BASED ON EIGHT HOURS/DAY OPERATION)

| Environment | Clean: Un-Exposed | | | Moderate: Exposed | | | Extreme: Harsh | | |
|----------------------------------|-------------------|----------|---------|-------------------|---------|----------------|----------------|--------|----------------|
| | Low | Med. | Hi | Low | Med. | Hi | Low | Med. | Hi |
| Application Speed ⁽¹⁾ | | | | | | | | | |
| Greasing Interval | 1 year | 2 months | 2 weeks | 1 month | 2 weeks | ⁽²⁾ | 1 week | 1 week | ⁽²⁾ |

⁽¹⁾Low < 25% max RPM; 25% < Med. < 75%; 75% < Hi – See table B-5.

⁽²⁾Use extra caution due to heat generation.

Relubrication frequency and quantity are best developed through experience. At all times, follow Original Equipment Manufacturer's maintenance instructions.





TYPE E TAPERED ROLLER BEARING HOUSED UNIT PRODUCT DATA TABLES

The following tables include product specification information for Timken® Type E housed units. Contact your Timken engineer for more information.

| | |
|------------------------------------|------|
| Pillow Block: Two-Bolt Base | B-17 |
| Pillow Block: Four-Bolt Base | B-18 |
| Flange: Four-Bolt | B-19 |
| Flange: Piloted | B-20 |
| Take-Up: Wide Slot | B-21 |
| Take-Up: Top Angle | B-22 |

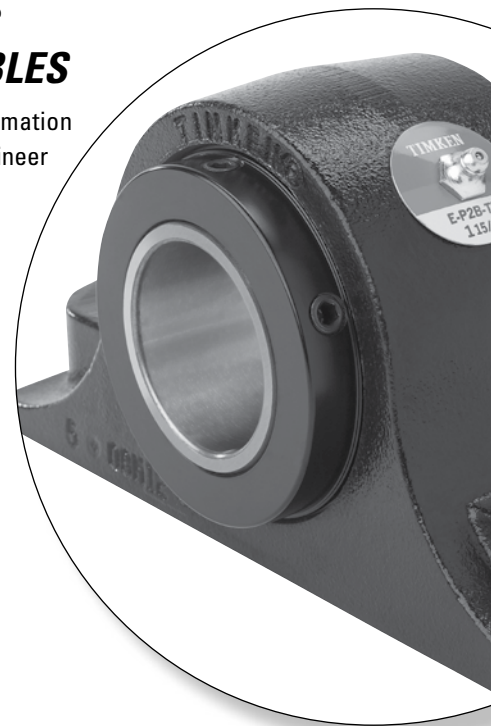



NOMENCLATURE

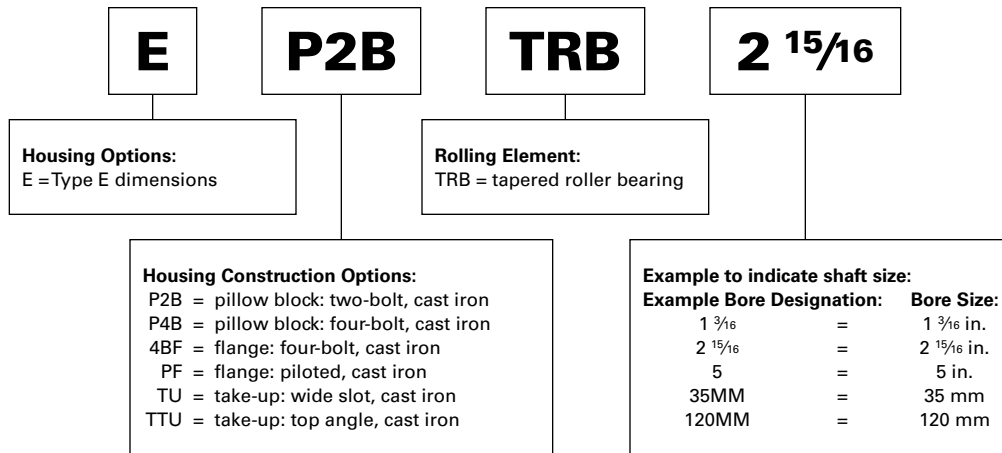

Fig. B-1. Type E nomenclature.

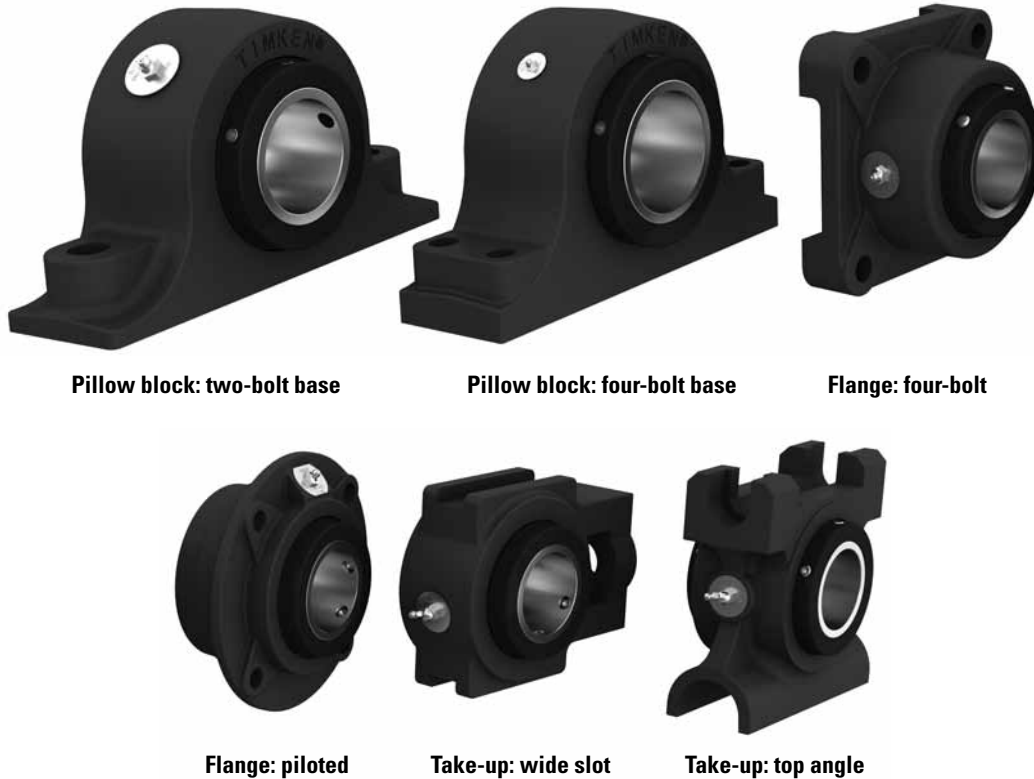
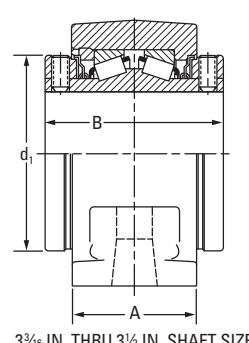
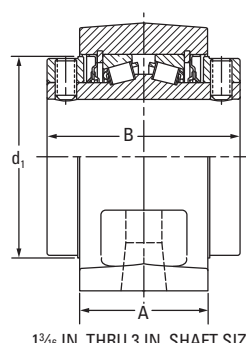
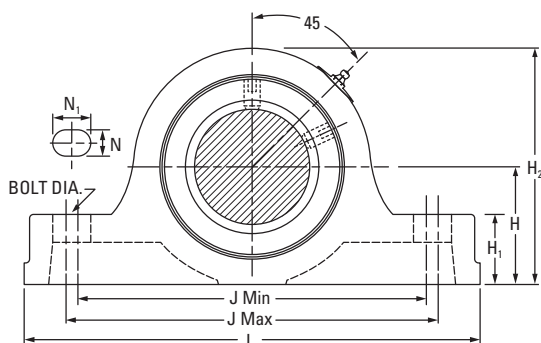

Fig. B-2. Type E housed unit types.

PILLOW BLOCK: TWO-BOLT BASE



| Shaft Dia. | Part No. | B | L | A | J | | Bolt Dia. | N | N ₁ | H ₁ | H ₂ | d ₁ | H | Approx. Wt. |
|------------|-------------------|-------|--------|-------|----------|----------|-----------|-------|----------------|----------------|----------------|----------------|-------|-------------|
| | | | | | Max. | Min. | | | | | | | | |
| in. mm | | in. | in. | in. | in. | in. | in. | in. | in. | in. | in. | in. | in. | lbs. |
| 1 3/16 | E-P2B-TRB-1 3/16 | 2 3/4 | 6 | 1 7/8 | 4 13/16 | 4 3/4 | 1/2 | 9/16 | 19/32 | 7/8 | 3 | 2 1/4 | 1 1/2 | 4 |
| 1 1/4 | E-P2B-TRB-1 1/4 | | | | | | | | | | | | | |
| 1 3/8 | E-P2B-TRB-1 3/8 | 3 | 7 3/8 | 2 1/8 | 5 7/8 | 5 5/8 | 1/2 | 5/8 | 3/4 | 1 1/8 | 3 3/4 | 2 3/4 | 1 7/8 | 7 |
| 1 7/16 | E-P2B-TRB-1 7/16 | | | | | | | | | | | | | |
| 35 mm | E-P2B-TRB-35MM | 3 3/8 | 7 7/8 | 2 3/8 | 6 3/8 | 6 1/8 | 1/2 | 5/8 | 3/4 | 1 1/4 | 4 1/4 | 3 3/16 | 2 1/8 | 10 |
| 1 1/2 | E-P2B-TRB-1 1/2 | | | | | | | | | | | | | |
| 1 5/8 | E-P2B-TRB-1 5/8 | 3 1/2 | 8 7/8 | 2 1/2 | 7 1/8 | 6 7/8 | 5/8 | 3/4 | 7/8 | 1 15/16 | 4 1/2 | 3 7/16 | 2 1/4 | 12 |
| 1 11/16 | E-P2B-TRB-1 11/16 | | | | | | | | | | | | | |
| 40 mm | E-P2B-TRB-40MM | 3 3/4 | 9 5/8 | 2 5/8 | 7 7/8 | 7 5/8 | 5/8 | 3/4 | 7/8 | 1 1/2 | 5 | 3 3/4 | 2 1/2 | 12 |
| 1 3/4 | E-P2B-TRB-1 3/4 | | | | | | | | | | | | | |
| 1 7/8 | E-P2B-TRB-1 7/8 | 4 | 10 1/2 | 2 7/8 | 8 5/8 | 8 3/8 | 5/8 | 3/4 | 7/8 | 1 5/8 | 5 23/32 | 4 1/16 | 2 3/4 | 12 |
| 1 15/16 | E-P2B-TRB-1 15/16 | | | | | | | | | | | | | |
| 2 | E-P2B-TRB-2 | 4 1/2 | 12 | 3 | 9 11/16 | 9 5/16 | 3/4 | 27/32 | 1 | 1 7/8 | 6 1/4 | 4 23/32 | 3 1/8 | 11 |
| 45 mm | E-P2B-TRB-45MM | | | | | | | | | | | | | |
| 50 mm | E-P2B-TRB-50MM | 5 | 14 | 3 1/2 | 11 13/16 | 10 13/16 | 7/8 | 1 | 1 13/16 | 2 1/4 | 7 1/2 | 5 17/32 | 3 3/4 | 12 |
| 55 mm | E-P2B-TRB-55MM | | | | | | | | | | | | | |
| 2 3/16 | E-P2B-TRB-2 3/16 | 4 | 10 1/2 | 2 7/8 | 8 5/8 | 8 3/8 | 5/8 | 3/4 | 7/8 | 1 5/8 | 5 23/32 | 4 1/16 | 2 3/4 | 15 |
| 2 1/4 | E-P2B-TRB-2 1/4 | | | | | | | | | | | | | |
| 2 7/16 | E-P2B-TRB-2 7/16 | 5 | 14 | 3 1/2 | 11 13/16 | 10 13/16 | 7/8 | 1 | 1 13/16 | 2 1/4 | 7 1/2 | 5 17/32 | 3 3/4 | 23 |
| 2 1/2 | E-P2B-TRB-2 1/2 | | | | | | | | | | | | | |
| 60 mm | E-P2B-TRB-60MM | 5 | 14 | 3 1/2 | 11 13/16 | 10 13/16 | 7/8 | 1 | 1 13/16 | 2 1/4 | 7 1/2 | 5 17/32 | 3 3/4 | 23 |
| 65 mm | E-P2B-TRB-65MM | | | | | | | | | | | | | |
| 2 11/16 | E-P2B-TRB-2 11/16 | 5 | 14 | 3 1/2 | 11 13/16 | 10 13/16 | 7/8 | 1 | 1 13/16 | 2 1/4 | 7 1/2 | 5 17/32 | 3 3/4 | 28 |
| 2 3/4 | E-P2B-TRB-2 3/4 | | | | | | | | | | | | | |
| 2 15/16 | E-P2B-TRB-2 15/16 | 5 | 14 | 3 1/2 | 11 13/16 | 10 13/16 | 7/8 | 1 | 1 13/16 | 2 1/4 | 7 1/2 | 5 17/32 | 3 3/4 | 27 |
| 3 | E-P2B-TRB-3 | | | | | | | | | | | | | |
| 70 mm | E-P2B-TRB-70MM | 5 | 14 | 3 1/2 | 11 13/16 | 10 13/16 | 7/8 | 1 | 1 13/16 | 2 1/4 | 7 1/2 | 5 17/32 | 3 3/4 | 28 |
| 75 mm | E-P2B-TRB-75MM | | | | | | | | | | | | | |
| 3 3/16 | E-P2B-TRB-3 3/16 | 5 | 14 | 3 1/2 | 11 13/16 | 10 13/16 | 7/8 | 1 | 1 13/16 | 2 1/4 | 7 1/2 | 5 17/32 | 3 3/4 | 27 |
| 3 1/4 | E-P2B-TRB-3 1/4 | | | | | | | | | | | | | |
| 3 7/16 | E-P2B-TRB-3 7/16 | 5 | 14 | 3 1/2 | 11 13/16 | 10 13/16 | 7/8 | 1 | 1 13/16 | 2 1/4 | 7 1/2 | 5 17/32 | 3 3/4 | 48 |
| 3 1/2 | E-P2B-TRB-3 1/2 | | | | | | | | | | | | | |
| 80 mm | E-P2B-TRB-80MM | 5 | 14 | 3 1/2 | 11 13/16 | 10 13/16 | 7/8 | 1 | 1 13/16 | 2 1/4 | 7 1/2 | 5 17/32 | 3 3/4 | 48 |
| 85 mm | E-P2B-TRB-85MM | | | | | | | | | | | | | |
| 90 mm | E-P2B-TRB-90MM | 5 | 14 | 3 1/2 | 11 13/16 | 10 13/16 | 7/8 | 1 | 1 13/16 | 2 1/4 | 7 1/2 | 5 17/32 | 3 3/4 | 47 |
| | | | | | | | | | | | | | | |

PILLOW BLOCK: FOUR-BOLT BASE

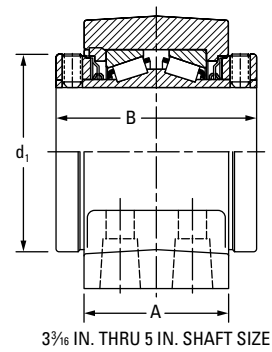
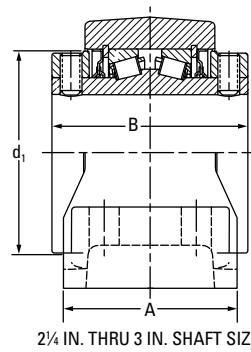
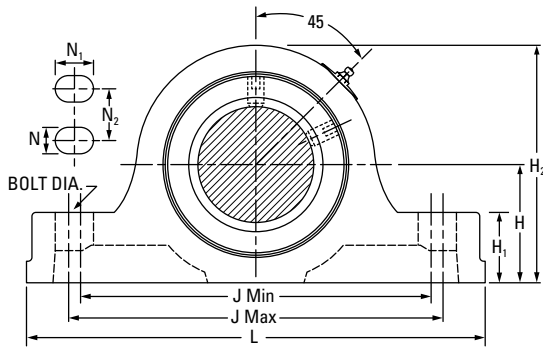

| Shaft Dia. in. mm | Part No. | B in. | L in. | A in. | J | | Bolt Dia. in. | N in. | N ₁ in. | N ₂ in. | H ₁ in. | H ₂ in. | d ₁ in. | H in. | Approx. Wt. lbs. |
|-------------------------|-------------------|----------|----------|----------|-------------|-------------|---------------------|----------|-----------------------|-----------------------|-----------------------|-----------------------|-----------------------|----------|------------------------|
| | | | | | Max. in. | Min. in. | | | | | | | | | |
| 2 1/4 | E-P4B-TRB-2 1/4 | 4 | 10 1/2 | 3 1/2 | 8 11/16 | 8 5/16 | 5/8 | 11/16 | 7/8 | 1 7/8 | 1 5/8 | 5 23/32 | 4 1/16 | 2 3/4 | 22 |
| 2 7/16 | E-P4B-TRB-2 7/16 | | | | | | | | | | | | | | 22 |
| 2 1/2 | E-P4B-TRB-2 1/2 | | | | | | | | | | | | | | 21 |
| 60 mm | E-P4B-TRB-60MM | | | | | | | | | | | | | | 22 |
| 65 mm | E-P4B-TRB-65MM | | | | | | | | | | | | | | 21 |
| 2 11/16 | E-P4B-TRB-2 11/16 | 4 1/2 | 12 | 4 | 9 13/16 | 9 3/16 | 5/8 | 11/16 | 1 | 2 1/8 | 1 7/8 | 6 1/4 | 4 23/32 | 3 1/8 | 30 |
| 2 3/4 | E-P4B-TRB-2 3/4 | | | | | | | | | | | | | | 29 |
| 2 15/16 | E-P4B-TRB-2 15/16 | | | | | | | | | | | | | | 28 |
| 3 | E-P4B-TRB-3 | | | | | | | | | | | | | | 28 |
| 70 mm | E-P4B-TRB-70MM | | | | | | | | | | | | | | 29 |
| 75 mm | E-P4B-TRB-75MM | 28 | | | | | | | | | | | | | |
| 3 3/16 | E-P4B-TRB-3 3/16 | 5 | 13 1/2 | 4 1/2 | 11 1/4 | 10 3/4 | 3/4 | 15/16 | 1 3/16 | 2 3/8 | 2 1/4 | 7 1/2 | 5 17/32 | 3 3/4 | 47 |
| 3 1/4 | E-P4B-TRB-3 1/4 | | | | | | | | | | | | | | 46 |
| 3 7/16 | E-P4B-TRB-3 7/16 | | | | | | | | | | | | | | 45 |
| 3 1/2 | E-P4B-TRB-3 1/2 | | | | | | | | | | | | | | 44 |
| 80 mm | E-P4B-TRB-80MM | | | | | | | | | | | | | | 47 |
| 85 mm | E-P4B-TRB-85MM | 45 | | | | | | | | | | | | | |
| 90 mm | E-P4B-TRB-90MM | 44 | | | | | | | | | | | | | |
| 3 15/16 | E-P4B-TRB-3 15/16 | 6 1/4 | 15 1/4 | 4 1/2 | 12 3/4 | 12 1/4 | 3/4 | 7/8 | 1 1/8 | 2 1/4 | 2 7/16 | 8 1/2 | 6 1/16 | 4 1/4 | 72 |
| 4 | E-P4B-TRB-4 | | | | | | | | | | | | | | 71 |
| 100 mm | E-P4B-TRB-100MM | | | | | | | | | | | | | | 71 |
| 4 7/16 | E-P4B-TRB-4 7/16 | | | | | | | | | | | | | | 91 |
| 4 1/2 | E-P4B-TRB-4 1/2 | | | | | | | | | | | | | | 90 |
| 110 mm | E-P4B-TRB-110MM | 92 | | | | | | | | | | | | | |
| 115 mm | E-P4B-TRB-115MM | 89 | | | | | | | | | | | | | |
| 4 15/16 | E-P4B-TRB-4 15/16 | 7 1/4 | 18 1/2 | 5 1/8 | 15 3/4 | 15 1/4 | 7/8 | 1 | 1 1/4 | 2 7/8 | 3 | 10 7/8 | 7 3/4 | 5 1/2 | 134 |
| 5 | E-P4B-TRB-5 | | | | | | | | | | | | | | 133 |
| 125 mm | E-P4B-TRB-125MM | | | | | | | | | | | | | | 134 |

FLANGE: FOUR-BOLT

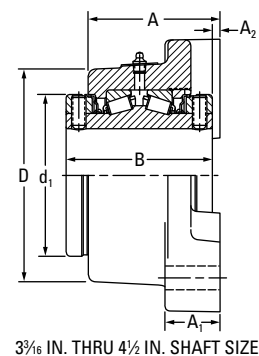
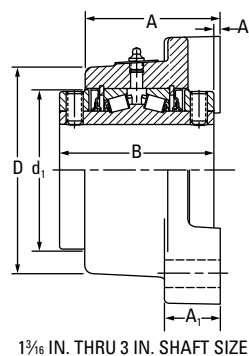
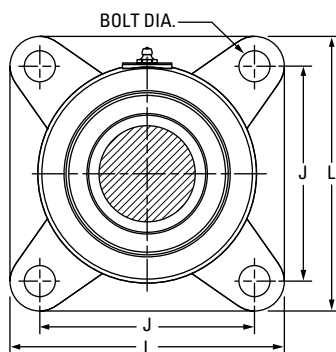

| Shaft Dia. | Part No. | B | L | A | J | A ₂ | Bolt Dia. | A ₁ | D | d ₁ | Approx. Wt. |
|------------|-------------------|-------|--------|---------|-------|----------------|-----------|----------------|---------|----------------|-------------|
| in. mm | | in. | in. | in. | in. | in. | in. | in. | in. | in. | lbs. |
| 1 3/16 | E-4BF-TRB-1 3/16 | 2 3/4 | 3 3/4 | 2 11/32 | 2 7/8 | 1/16 | 3/8 | 1 | 2 15/16 | 2 1/4 | 4 |
| 1 1/4 | E-4BF-TRB-1 1/4 | | | | | | | | | | |
| 1 3/8 | E-4BF-TRB-1 3/8 | | | | | | | | | | |
| 1 7/16 | E-4BF-TRB-1 7/16 | 3 | 4 5/8 | 2 19/32 | 3 1/2 | 1/16 | 1/2 | 1 1/16 | 3 1/2 | 2 3/4 | 7 |
| 35 mm | E-4BF-TRB-35MM | | | | | | | | | | |
| 1 1/2 | E-4BF-TRB-1 1/2 | | | | | | | | | | |
| 1 5/8 | E-4BF-TRB-1 5/8 | 3 3/8 | 5 3/8 | 2 31/32 | 4 1/8 | 1/8 | 1/2 | 1 3/16 | 4 3/16 | 3 3/16 | 11 |
| 1 11/16 | E-4BF-TRB-1 11/16 | | | | | | | | | | |
| 40 mm | E-4BF-TRB-40MM | | | | | | | | | | |
| 1 3/4 | E-4BF-TRB-1 3/4 | 3 1/2 | 5 5/8 | 3 3/32 | 4 3/8 | 1/8 | 1/2 | 1 3/16 | 4 7/16 | 3 7/16 | 12 |
| 1 7/8 | E-4BF-TRB-1 7/8 | | | | | | | | | | |
| 1 15/16 | E-4BF-TRB-1 15/16 | | | | | | | | | | |
| 2 | E-4BF-TRB-2 | 3 3/4 | 6 1/4 | 3 9/32 | 4 7/8 | 1/8 | 5/8 | 1 3/8 | 4 7/8 | 3 3/4 | 16 |
| 45 mm | E-4BF-TRB-45MM | | | | | | | | | | |
| 50 mm | E-4BF-TRB-50MM | | | | | | | | | | |
| 2 3/16 | E-4BF-TRB-2 3/16 | 4 | 6 7/8 | 3 9/16 | 5 3/8 | 3/16 | 5/8 | 1 1/2 | 5 5/16 | 4 1/16 | 21 |
| 55 mm | E-4BF-TRB-55MM | | | | | | | | | | |
| 2 1/4 | E-4BF-TRB-2 1/4 | | | | | | | | | | |
| 2 7/16 | E-4BF-TRB-2 7/16 | 4 1/2 | 7 3/4 | 3 15/16 | 6 | 3/16 | 3/4 | 1 5/8 | 6 | 4 23/32 | 21 |
| 2 1/2 | E-4BF-TRB-2 1/2 | | | | | | | | | | |
| 60 mm | E-4BF-TRB-60MM | | | | | | | | | | |
| 65 mm | E-4BF-TRB-65MM | 5 | 9 1/4 | 4 1/2 | 7 | 1/4 | 3/4 | 1 7/8 | 7 1/4 | 5 17/32 | 21 |
| 2 11/16 | E-4BF-TRB-2 11/16 | | | | | | | | | | |
| 2 3/4 | E-4BF-TRB-2 3/4 | | | | | | | | | | |
| 2 15/16 | E-4BF-TRB-2 15/16 | 5 | 9 1/4 | 4 1/2 | 7 | 1/4 | 3/4 | 1 7/8 | 7 1/4 | 5 17/32 | 29 |
| 3 | E-4BF-TRB-3 | | | | | | | | | | |
| 70 mm | E-4BF-TRB-70MM | | | | | | | | | | |
| 75 mm | E-4BF-TRB-75MM | 6 1/4 | 10 1/4 | 5 5/8 | 7 3/4 | 1/4 | 7/8 | 2 1/8 | 8 1/4 | 6 1/16 | 28 |
| 3 3/16 | E-4BF-TRB-3 3/16 | | | | | | | | | | |
| 3 1/4 | E-4BF-TRB-3 1/4 | | | | | | | | | | |
| 3 7/16 | E-4BF-TRB-3 7/16 | 6 3/4 | 10 7/8 | 5 15/16 | 8 3/4 | 3/8 | 7/8 | 2 7/16 | 8 3/4 | 6 47/64 | 29 |
| 3 1/2 | E-4BF-TRB-3 1/2 | | | | | | | | | | |
| 80 mm | E-4BF-TRB-80MM | | | | | | | | | | |
| 85 mm | E-4BF-TRB-85MM | 6 3/4 | 10 7/8 | 5 15/16 | 8 3/4 | 3/8 | 7/8 | 2 7/16 | 8 3/4 | 6 47/64 | 28 |
| 90 mm | E-4BF-TRB-90MM | | | | | | | | | | |
| 3 15/16 | E-4BF-TRB-3 15/16 | | | | | | | | | | |
| 4 | E-4BF-TRB-4 | 6 3/4 | 10 7/8 | 5 15/16 | 8 3/4 | 3/8 | 7/8 | 2 7/16 | 8 3/4 | 6 47/64 | 28 |
| 100 mm | E-4BF-TRB-100MM | | | | | | | | | | |
| 4 7/16 | E-4BF-TRB-4 7/16 | | | | | | | | | | |
| 4 1/2 | E-4BF-TRB-4 1/2 | 6 3/4 | 10 7/8 | 5 15/16 | 8 3/4 | 3/8 | 7/8 | 2 7/16 | 8 3/4 | 6 47/64 | 28 |
| 110 mm | E-4BF-TRB-110MM | | | | | | | | | | |
| 115 mm | E-4BF-TRB-115MM | | | | | | | | | | |

TAPERED ROLLER BEARING TYPE E HOUSED UNITS

FLANGE: PILOTED

FLANGE: PILOTED

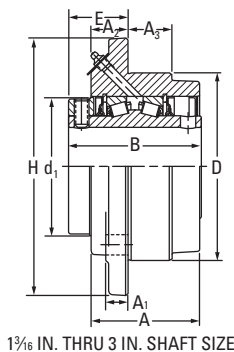
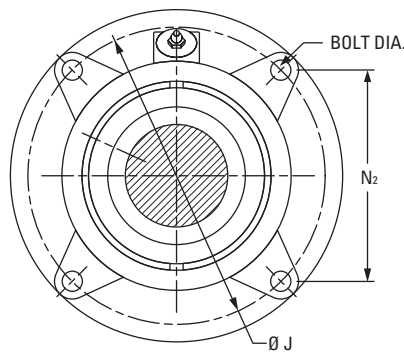

1 1/16 IN. THRU 3 IN. SHAFT SIZE

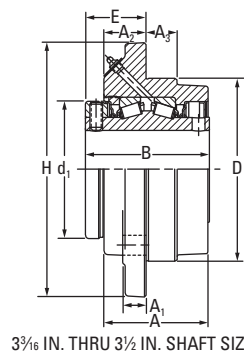

3 3/16 IN. THRU 3 1/2 IN. SHAFT SIZE

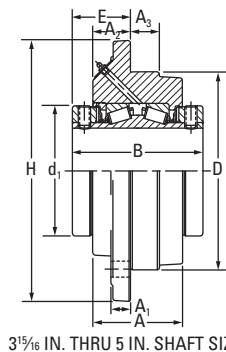

3 15/16 IN. THRU 5 IN. SHAFT SIZE

| Shaft Dia. | Part No. | B | H | A | N ₂ | J | A ₃ | Bolt Dia. | E | A ₁ | D ⁽¹⁾ | d ₁ | A ₂ | Approx. Wt. |
|------------|------------------|-------|--------|---------|----------------------|--------|----------------|--------------------|---------|----------------|------------------|----------------|----------------|-------------|
| in. mm | | in. | in. | in. | in. | in. | in. | in. | in. | in. | in. | in. | in. | lbs. |
| 1 3/16 | E-PF-TRB-1 3/16 | 2 3/4 | 5 | 2 7/32 | 2.92 | 4 1/8 | 3/4 | 3/8 | 1 5/16 | 7/16 | 3 3/8 | 2 1/4 | 27/32 | 5 |
| 1 1/4 | E-PF-TRB-1 1/4 | | | | | | | | | | | | | |
| 1 3/8 | E-PF-TRB-1 3/8 | | | | | | | | | | | | | |
| 1 7/16 | E-PF-TRB-1 7/16 | 3 | 5 1/4 | 2 15/32 | 3.09 | 4 3/8 | 7/8 | 3/8 | 1 1/2 | 1/2 | 3 5/8 | 2 3/4 | 1 1/32 | 6 |
| 35 mm | E-PF-TRB-35MM | | | | | | | | | | | | | |
| 1 1/2 | E-PF-TRB-1 1/2 | 3 3/8 | 6 1/8 | 2 25/32 | 3.62 | 5 1/8 | 1 1/16 | 7/16 | 1 9/16 | 1/2 | 4 1/4 | 3 3/16 | 1 1/32 | 9 |
| 1 5/8 | E-PF-TRB-1 5/8 | | | | | | | | | | | | | |
| 1 11/16 | E-PF-TRB-1 11/16 | | | | | | | | | | | | | |
| 40 mm | E-PF-TRB-40MM | | | | | | | | | | | | | |
| 1 3/4 | E-PF-TRB-1 3/4 | 3 1/2 | 6 3/8 | 2 29/32 | 3.80 | 5 3/8 | 1 3/16 | 7/16 | 1 9/16 | 9/16 | 4 1/2 | 3 7/16 | 1 1/32 | 10 |
| 1 7/8 | E-PF-TRB-1 7/8 | | | | | | | | | | | | | |
| 1 15/16 | E-PF-TRB-1 15/16 | | | | | | | | | | | | | |
| 2 | E-PF-TRB-2 | | | | | | | | | | | | | |
| 45 mm | E-PF-TRB-45MM | | | | | | | | | | | | | |
| 50 mm | E-PF-TRB-50MM | 3 3/4 | 7 1/8 | 3 3/32 | 4.24 | 6 | 1 3/16 | 1/2 | 1 11/16 | 9/16 | 5 | 3 3/4 | 1 3/32 | 13 |
| 2 3/16 | E-PF-TRB-2 3/16 | | | | | | | | | | | | | |
| 55 mm | E-PF-TRB-55MM | | | | | | | | | | | | | |
| 2 1/4 | E-PF-TRB-2 1/4 | 4 | 7 5/8 | 3 5/16 | 4.60 | 6 1/2 | 1 5/16 | 1/2 | 1 13/16 | 5/8 | 5 1/2 | 4 1/16 | 1 3/16 | 17 |
| 2 7/16 | E-PF-TRB-2 7/16 | | | | | | | | | | | | | |
| 2 1/2 | E-PF-TRB-2 1/2 | | | | | | | | | | | | | |
| 60 mm | E-PF-TRB-60MM | | | | | | | | | | | | | |
| 65 mm | E-PF-TRB-65MM | | | | | | | | | | | | | |
| 2 11/16 | E-PF-TRB-2 11/16 | | | | | | | | | | | | | |
| 2 3/4 | E-PF-TRB-2 3/4 | 4 1/2 | 8 3/4 | 3 11/16 | 5.30 | 7 1/2 | 1 1/2 | 5/8 | 2 | 3/4 | 6 3/8 | 4 23/32 | 1 1/4 | 25 |
| 2 15/16 | E-PF-TRB-2 15/16 | | | | | | | | | | | | | |
| 3 | E-PF-TRB-3 | | | | | | | | | | | | | |
| 70 mm | E-PF-TRB-70MM | | | | | | | | | | | | | |
| 75 mm | E-PF-TRB-75MM | | | | | | | | | | | | | |
| 3 3/16 | E-PF-TRB-3 3/16 | 5 | 10 1/4 | 4 3/16 | 6.10 | 8 5/8 | 1 1/4 | 3/4 | 2 7/16 | 15/16 | 7 3/8 | 5 17/32 | 1 11/16 | 43 |
| 3 1/4 | E-PF-TRB-3 1/4 | | | | | | | | | | | | | |
| 3 7/16 | E-PF-TRB-3 7/16 | | | | | | | | | | | | | |
| 3 1/2 | E-PF-TRB-3 1/2 | | | | | | | | | | | | | |
| 80 mm | E-PF-TRB-80MM | | | | | | | | | | | | | |
| 85 mm | E-PF-TRB-85MM | | | | | | | | | | | | | |
| 90 mm | E-PF-TRB-90MM | 6 1/4 | 10 7/8 | 4 1/2 | 6.63 | 9 3/8 | 1 1/2 | 3/4 | 2 11/16 | 1 | 8 1/8 | 6 1/16 | 1 13/16 | 58 |
| 3 15/16 | E-PF-TRB-3 15/16 | | | | | | | | | | | | | |
| 4 | E-PF-TRB-4 | | | | | | | | | | | | | |
| 100 mm | E-PF-TRB-100MM | 6 3/4 | 13 1/2 | 4 5/8 | 5 7/8 ⁽²⁾ | 11 3/4 | 1 1/2 | 3/4 ⁽²⁾ | 3 | 1 | 10 1/4 | 6 47/64 | 1 15/16 | 92 |
| 4 7/16 | E-PF-TRB-4 7/16 | | | | | | | | | | | | | |
| 4 1/2 | E-PF-TRB-4 1/2 | | | | | | | | | | | | | |
| 110 mm | E-PF-TRB-110MM | | | | | | | | | | | | | |
| 115 mm | E-PF-TRB-115MM | | | | | | | | | | | | | |
| 4 15/16 | E-PF-TRB-4 15/16 | 7 1/4 | 14 3/4 | 5 1/16 | 6 3/8 ⁽²⁾ | 12 3/4 | 1 3/4 | 7/8 ⁽²⁾ | 2 31/32 | 1 1/4 | 11 | 7 3/4 | 1 7/8 | 125 |
| 5 | E-PF-TRB-5 | | | | | | | | | | | | | |
| 125 mm | E-PF-TRB-125MM | | | | | | | | | | | | | 126 |

⁽¹⁾+0.000 in./ 0.002 in.

⁽²⁾Six holes equally spaced (chordal spacing shown).

Note: 1 3/16 to 3 1/2 utilize one collar; 3 15/16 to 5 utilize two collars.

TAKE-UP: WIDE SLOT

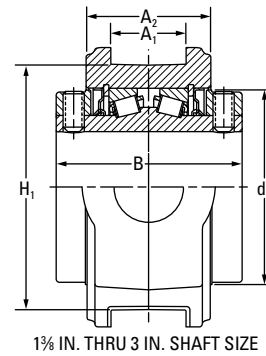
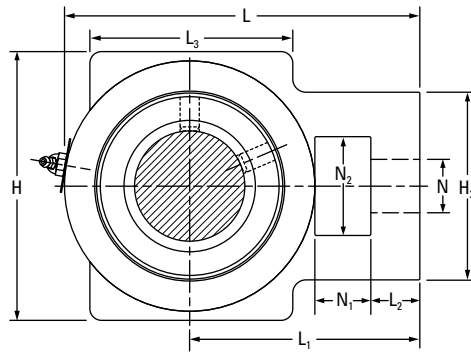

1 3/8 IN. THRU 3 IN. SHAFT SIZE

| Shaft Dia. | Part No. | B | L | A ₁ | L ₃ | L ₁ | N | L ₂ | N ₁ | H ₂ | N ₂ | d ₁ | H ₁ | H | A ₂ | Approx. Wt. |
|------------|------------------|-------|---------|----------------|----------------|----------------|---------|----------------|----------------|----------------|----------------|----------------|----------------|-------|----------------|----------------------------------|
| in. mm | | in. | in. | in. | in. | in. | in. | in. | in. | in. | in. | in. | in. | in. | in. | lbs. |
| 1 3/8 | E-TU-TRB-1 3/8 | 3 | 5 3/32 | 17/32 | 2 3/4 | 3 7/32 | 7/8 | 11/16 | 5/8 | 2 7/16 | 1 7/16 | 2 3/4 | 3 1/2 | 4 1/8 | 2 1/16 | 7 |
| 1 7/16 | E-TU-TRB-1 7/16 | | | | | | | | | | | | | | | |
| 35 mm | E-TU-TRB-35MM | | | | | | | | | | | | | | | |
| 1 1/2 | E-TU-TRB-1 1/2 | 3 3/8 | 6 | 11/16 | 3 1/4 | 3 13/16 | 1 1/8 | 15/16 | 3/4 | 3 5/16 | 1 15/16 | 3 3/16 | 4 | 4 3/4 | 2 5/16 | 12 11 11 11 |
| 1 5/8 | E-TU-TRB-1 5/8 | | | | | | | | | | | | | | | |
| 1 11/16 | E-TU-TRB-1 11/16 | | | | | | | | | | | | | | | |
| 40 mm | E-TU-TRB-40MM | | | | | | | | | | | | | | | |
| 1 3/4 | E-TU-TRB-1 3/4 | | | | | | | | | | | | | | | |
| 1 7/8 | E-TU-TRB-1 7/8 | 3 1/2 | 6 5/16 | 11/16 | 3 3/4 | 3 5/16 | 1 1/8 | 15/16 | 3/4 | 3 5/16 | 1 15/16 | 3 7/16 | 4 | 4 3/4 | 2 7/16 | 13 |
| 1 15/16 | E-TU-TRB-1 15/16 | | | | | | | | | | | | | | | |
| 2 | E-TU-TRB-2 | | | | | | | | | | | | | | | |
| 45 mm | E-TU-TRB-45MM | 3 3/4 | 7 1/8 | 13/16 | 3 3/4 | 4 5/8 | 1 1/4 | 1 | 1 1/4 | 3 7/8 | 2 1/4 | 3 3/4 | 4 1/2 | 5 1/4 | 2 9/16 | 16 |
| 50 mm | E-TU-TRB-50MM | | | | | | | | | | | | | | | |
| 2 3/16 | E-TU-TRB-2 3/16 | | | | | | | | | | | | | | | |
| 55 mm | E-TU-TRB-55MM | 4 | 7 13/16 | 1 1/16 | 4 1/2 | 5 1/16 | 1 3/8 | 1 1/16 | 1 1/4 | 4 5/16 | 2 1/2 | 4 1/16 | 5 1/8 | 6 | 2 3/4 | 21 20 20 21 20 |
| 2 1/4 | E-TU-TRB-2 1/4 | | | | | | | | | | | | | | | |
| 2 7/16 | E-TU-TRB-2 7/16 | | | | | | | | | | | | | | | |
| 2 1/2 | E-TU-TRB-2 1/2 | | | | | | | | | | | | | | | |
| 60 mm | E-TU-TRB-60MM | | | | | | | | | | | | | | | |
| 65 mm | E-TU-TRB-65MM | 4 1/2 | 9 3/16 | 1 13/16 | 4 3/4 | 5 7/8 | 1 11/16 | 1 1/8 | 1 1/2 | 4 15/16 | 2 3/4 | 4 23/32 | 5 5/16 | 6 3/4 | 3 | 30 30 29 28 30 29 |
| 2 11/16 | E-TU-TRB-2 11/16 | | | | | | | | | | | | | | | |
| 2 3/4 | E-TU-TRB-2 3/4 | | | | | | | | | | | | | | | |
| 2 15/16 | E-TU-TRB-2 15/16 | | | | | | | | | | | | | | | |
| 3 | E-TU-TRB-3 | | | | | | | | | | | | | | | |
| 70 mm | E-TU-TRB-70MM | | | | | | | | | | | | | | | |
| 75 mm | E-TU-TRB-75MM | | | | | | | | | | | | | | | |



TAPERED ROLLER BEARING TYPE E HOUSED UNITS

TAKE-UP: TOP ANGLE

TAKE-UP: TOP ANGLE

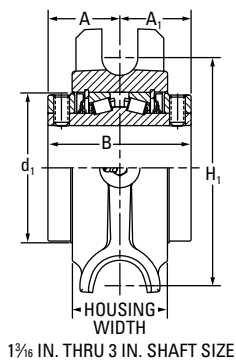
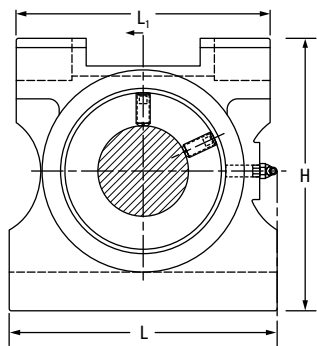

1 3/16 IN. THRU 3 IN. SHAFT SIZE

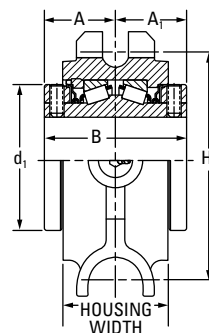

3 3/16 IN. THRU 4 IN. SHAFT SIZE

| Shaft Dia. | Part No. | B | H ₁ | H | d ₁ | A | A ₁ | Housing Width | L | L ₁ | Approx. Wt. |
|------------|-------------------|-------|----------------|--------|----------------|-------|----------------|---------------|-------|----------------|-------------|
| in. mm | | in. | in. | in. | in. | in. | in. | in. | in. | in. | lbs. |
| 1 3/4 | E-TTU-TRB-1 3/4 | 3 1/2 | 5 3/16 | 6 3/8 | 3 7/16 | 1 3/4 | 1 3/4 | 2 9/16 | 6 1/2 | 6 | 14 |
| 1 7/8 | E-TTU-TRB-1 7/8 | | | | | | | | | | |
| 1 15/16 | E-TTU-TRB-1 15/16 | | | | | | | | | | |
| 2 | E-TTU-TRB-2 | | | | | | | | | | |
| 45 mm | E-TTU-TRB-45MM | | | | | | | | | | |
| 50 mm | E-TTU-TRB-50MM | 3 3/4 | 5 13/16 | 6 7/8 | 3 3/4 | 1 7/8 | 1 7/8 | 2 9/16 | 6 3/4 | 7 | 17 |
| 2 3/16 | E-TTU-TRB-2 3/16 | | | | | | | | | | |
| 55 mm | E-TTU-TRB-55MM | | | | | | | | | | |
| 2 1/4 | E-TTU-TRB-2 1/4 | | | | | | | | | | |
| 2 7/16 | E-TTU-TRB-2 7/16 | | | | | | | | | | |
| 2 1/2 | E-TTU-TRB-2 1/2 | 4 | 6 1/4 | 7 7/16 | 4 1/16 | 2 | 2 | 3 | 7 1/2 | 7 | 21 |
| 60 mm | E-TTU-TRB-60MM | | | | | | | | | | |
| 65 mm | E-TTU-TRB-65MM | | | | | | | | | | |
| 2 11/16 | E-TTU-TRB-2 11/16 | | | | | | | | | | |
| 2 3/4 | E-TTU-TRB-2 3/4 | | | | | | | | | | |
| 2 15/16 | E-TTU-TRB-2 15/16 | 4 1/2 | 7 3/16 | 8 5/16 | 4 23/32 | 2 1/4 | 2 1/4 | 3 | 8 1/2 | 8 | 28 |
| 3 | E-TTU-TRB-3 | | | | | | | | | | |
| 70 mm | E-TTU-TRB-70MM | | | | | | | | | | |
| 75 mm | E-TTU-TRB-75MM | | | | | | | | | | |
| 3 3/16 | E-TTU-TRB-3 3/16 | | | | | | | | | | |
| 3 1/4 | E-TTU-TRB-3 1/4 | 5 | 8 5/16 | 9 5/8 | 5 17/32 | 2 1/2 | 2 1/2 | 3 3/4 | 9 1/2 | 9 | 44 |
| 3 7/16 | E-TTU-TRB-3 7/16 | | | | | | | | | | |
| 3 1/2 | E-TTU-TRB-3 1/2 | | | | | | | | | | |
| 80 mm | E-TTU-TRB-80MM | | | | | | | | | | |
| 85 mm | E-TTU-TRB-85MM | | | | | | | | | | |
| 90 mm | E-TTU-TRB-90MM | 6 1/4 | 9 1/16 | 11 | 6 1/16 | 3 1/8 | 3 1/8 | 4 3/4 | 11 | 10 1/2 | 70 |
| 3 15/16 | E-TTU-TRB-3 15/16 | | | | | | | | | | |
| 4 | E-TTU-TRB-4 | | | | | | | | | | |
| 100 mm | E-TTU-TRB-100MM | | | | | | | | | | |



INDEX

TAPERED ROLLER BEARING TYPE E HOUSED UNITS

| | |
|--|------|
| E-4BF Flange: Four-Bolt | B-19 |
| E-P2B Pillow Block: Two-Bolt Base | B-17 |
| E-P4B Pillow Block: Four-Bolt Base | B-18 |
| E-PF Flange: Piloted | B-20 |
| E-TTU Take-Up: Top Angle | B-22 |
| E-TU Take-Up: Wide Slot | B-21 |
| Introduction and Engineering | B-2 |
| Tapered Roller Bearing Type E Housed Units | B-1 |



TIMKEN

The Timken team applies their know-how to improve the reliability and performance of machinery in diverse markets worldwide. The company designs, makes and markets high-performance steel as well as mechanical components, including bearings, gears, chain and related mechanical power transmission products and services.

www.timken.com

