

BOWMAN

BEARINGS AND COMPONENTS



Contents

Company Profile

Products

Wrapped Bearings Technical Information WMU & WMXMU & WMX

Wrapped Bearings Metric Plain U Type

Wrapped Bearings Metric Flanged U Type

Wrapped Bearings Metric & Imperial, Strip & Washers U Type

Wrapped Bearings Imperial Plain U Type

Wrapped Bearings Metric Plain X Type

Wrapped Bearings Imperial Plain X Type

Wrapped Bearings Metric & Imperial, Strip & Washers X Type

Wrapped Bearings Technical Information SWB & CuSn8

Wrapped Bearings Imperial Plain SWB Type

Wrapped Bearings Metric Plain SWB Type

Wrapped Bearings Metric Plain Bronze CuSn8

Wrapped Bearings Metric Flanged Bronze CuSn8

Fitting Instructions

Cast Bronze Bearings with Graphite Lubrication

Cast Bronze Bearings with Graphite Lubrication Plain

Cast Bronze Bearings with Graphite Lubrication Flanged

Cast Bronze Thrust Washers with Graphite Lubrication

Cast Bronze Plates with Graphite Lubrication

Plastic Bearings WMG & WMFG Series Mechanical Properties

Plastic Bearings Metric Plain WMG

Plastic Bearings Metric Flanged WMFG

Plastic Thrust Washers WMWG

Acetal Thrust Washers TWP

Acetal Thrust Washers TWP Technical Data & Sizes

Ball Bearings

Ball Bearings Metric 6000 Series

Ball Bearings Metric 6200 & 6300 Series

Ball Bearings Metric Miniature Series

Ball Bearings Imperial Miniature Series

Services and Information



(3 of the 5 Bowman Business Units)

Introduction

Bowman was founded in 1972 and in 1984 the manufacture of certain products commenced. As well as its own manufacture, the company holds exclusive agencies of other manufacturer's products, which complement Bowman's range.

Bowman International Limited was first approved for ISO 9001: 1994 in 1999 and in 2010 was approved to the later approval BS EN ISO 9001: 2008 (Certificate No. 960929).

Bowman is recognised as a leading supplier to original equipment manufacturers, stockists and distributors across a wide range of industries and is one of the leading companies in Europe specialising in the design, supply and manufacture of plain bearings, sintered components and brushes for electric motors.

In 2003 ball and needle bearings were introduced to our range. Bowman is now expanding into exporting throughout the world.

Company objectives

To continue to offer our customers the highest standard of service in our Industry. It is our intention to remain at the forefront of bearing supply and design and to continue our development into new bearing materials and lubricants.

We will also continue to tailor our range of products and services in line with our customers' changing aspirations and requirements.

Bowman's product ranges:-

- Sintered components
- BowMet® Bearings
- Wrapped bearings
- White metal bearings
- Solid bronze bearings
- Plastic bearings
- Composite bearings
- Carbon bearings
- Special designed bearings
- Brushes for electric motors & slip rings
- Carbon seals & products
- Ball bearings
- Needle bearings

We pride ourselves in giving excellent service which includes:-

- Competitive pricing and payment terms
- Large stocks
- Next day delivery
- Just-in-time/kan ban scheduling
- Full technical and design service
- Machining facility for special sizes of bearings and carbon products

Other products are being added to our range as the market dictates.

Products

WMU PTFE LINED

Dry Sliding Bearings



Self lubricated plain & flanged bearings & strip. Carbon steel shell with sintered bronze layer filled with PTFE. Available in metric and imperial sizes from stock. Also bronze shell versions can be supplied to order.

WMX ACETAL LINED

Lubricated Sliding Bearings



Oil or grease lubricated bearings. Carbon steel shell with sintered bronze layer with a co-acetal polymer layer. Available in metric and imperial sizes from stock.

Standard Wrapped Bearings



Oil or grease lubricated bearings. Carbon Steel shell with sintered bronze lining. Various metric and imperial sizes available from stock.

BOWMAN OILLESS Bronze Bearings with Graphite Lubrication



Various material specifications are offered. Standard and special shapes are available.

WMT Ball Bearings



Ball bearings in chrome or stainless steel. ABEC 1, 3 or 5. With or without seals. Various ranges available from stock.

White Metal Bearings



White metal bearings can be manufactured to order in various material grades.

BOWMET



Revolutionary new wrapped bearings made in Toughmet spinodal bronze. For use in high load and harsh environmental applications. See separate catalogue for details.

Plastic Bearings Moulded & Machined



Can be manufactured in many different types of plastic material to suit various applications. Machined for small quantities and moulded for large quantities.

CuSn8 Hard Bronze Bearings



Offered with lubrication pockets, grooves or thru holes. Used for heavy load applications.

WMU and WMLF Self Lubricated Bearings



(Dimensions and tolerances to ISO 3547)

Stock range includes

- Metric plain
- Metric flanged
- Metric washers
- Metric strip
- Imperial plain
- Imperial washers
- Imperial strip*

WMU and WMLF Technical Data – Summary

Structure	Steel support strip S.A.E 1010. Sintered Bronze layer. PTFE.
PV	1.8 N/mm ² x m/s
Static load	250 N/mm ²
Dynamic load	140 N/mm ²
Maximum sliding speed	2.5 m/s dry 5.0 m/s with oil
Operating temperature	-200°C to +280°C
Thermal conductivity	42 W/mK
Coefficient of friction	
WMU Dry	0.02 to 0.20
WMU Oiled	0.02 to 0.15
WMLF Dry	0.04 to 0.30
WMLF Oiled	0.02 to 0.10
Recommended housing tolerance	4.5mm/5.5mm H6 7.0mm/305mm H7
Recommended shaft tolerance	3.0mm/4.0mm h6 5.0mm/75mm f7 80mm/300mm h8
Recommended shaft finish	Ra ≤ 0.4um (N5)
Recommended shaft hardness	HB > 200

WMUB Bronze Support Strip instead of Steel

Has greater resistance to corrosion than standard WMU product.

Range, dimensions and tolerances are as standard WMU product.

WMX Externally Lubricated Bearings



(Dimensions and tolerances to ISO 3547)

Stock range includes

- Metric plain
- Metric washers
- Metric strip
- Imperial plain*
- Imperial washers*
- Imperial strip*

* Some sizes supplied to order only, minimum order quantity may apply.

WMX Technical Data – Summary

Structure	Steel support strip S.A.E 1010. Sintered Bronze layer. Co-Acetal polymer.
Static load	140 N/mm ²
Dynamic load	70 N/mm ²
Maximum sliding speed	2.5 m/s with grease
Operating temperature	-40°C to +110°C
Intermittent maximum temperature	130°C
Thermal conductivity	2W/mK
PV	2.8 N/mm ² x m/s
Coefficient of friction	0.05 to 0.12 with grease
Recommended housing tolerance	H7
Recommended shaft tolerance	h8
Recommended shaft finish	HB > 200
Recommended shaft hardness	HB > 200

Fitting Guidelines

1. Always use a fitting pin and fitting collar. See our fitting instructions on page 20.
2. Lubricate back of bearing prior to assembly.
3. Chamfer lead in on housing to assist with assembly.

Bowman International Limited reserve the right to change specifications without prior notice. E & OE



Wrapped Metric Plain Bearings. PTFE U Type

Inside Diameter When Fitted		Housing Diameter (Nominal OD)		Shaft Diameter		Length +/- 0.25	Part Number
3	+0.048 0.000	4.5	+0.006 0.000	3	0.000 -0.006	3	TFP 0304503
						4	TFP 0304504
						5	TFP 0304505
						6	TFP 0304506
4	+0.048 0.000	5.5	+0.008 0.000	4	0.000 -0.008	3	TFP 0405503
						4	TFP 0405504
						6	TFP 0405506
						10	TFP 0405510
5	+0.055 -0.010	7	+0.015 0.000	5	-0.010 -0.022	5	TFP 050705
						8	TFP 050708
						10	TFP 050710
6	+0.055 -0.010	8	+0.015 0.000	6	-0.010 -0.022	6	TFP 060806
						8	TFP 060808
						10	TFP 060810
7	+0.055 -0.010	9	+0.015 0.000	7	-0.013 -0.028	10	TFP 070910
						10	TFP 070910
8	+0.055 -0.010	10	+0.015 0.000	8	-0.013 -0.028	8	TFP 081008
						12	TFP 081012
						15	TFP 081015
10	+0.058 -0.010	12	+0.018 0.000	10	-0.013 -0.028	8	TFP 101208
						10	TFP 101210
						12	TFP 101212
						15	TFP 101215
						20	TFP 101220
12	+0.058 -0.010	14	+0.018 0.000	12	-0.016 -0.034	12	TFP 121412
						15	TFP 121415
						20	TFP 121420
						25	TFP 121425
13	+0.058 -0.010	15	+0.018 0.000	13	-0.016 -0.034	10	TFP 131510
						20	TFP 131520
14	+0.058 -0.010	16	+0.018 0.000	14	-0.016 -0.034	10	TFP 141610
						12	TFP 141612
						15	TFP 141615
						20	TFP 141620
						25	TFP 141625
15	+0.058 -0.010	17	+0.018 0.000	15	-0.016 -0.034	10	TFP 151710
						12	TFP 151712
						15	TFP 151715
						20	TFP 151720
						25	TFP 151725
16	+0.058 -0.010	18	+0.018 0.000	16	-0.016 -0.034	10	TFP 161810
						12	TFP 161812
						15	TFP 161815
						20	TFP 161820
						25	TFP 161825
17	+0.061 -0.010	19	+0.021 0.000	17	-0.016 -0.034	15	TFP 171915
						20	TFP 171920
18	+0.061 -0.010	20	+0.021 0.000	18	-0.016 -0.034	15	TFP 182015
						20	TFP 182020
						25	TFP 182025

Inside Diameter When Fitted		Housing Diameter (Nominal OD)		Shaft Diameter		Length +/- 0.25	Part Number
20	+0.071 -0.010	22	+0.021 0.000	20	-0.020 -0.041	10	TFP 202210
20	+0.071 -0.010	23	+0.021 0.000	20	-0.020 -0.041	10	TFP 202310
						15	TFP 202315
						20	TFP 202320
						25	TFP 202325
22	+0.071 -0.010	25	+0.021 0.000	22	-0.020 -0.041	15	TFP 222515
						20	TFP 222520
						25	TFP 222525
						30	TFP 222530
24	+0.071 -0.010	27	+0.021 0.000	24	-0.020 -0.041	20	TFP 242720
						25	TFP 242725
						30	TFP 242730
25	+0.071 -0.010	28	+0.021 0.000	25	-0.020 -0.041	12	TFP 252812
						15	TFP 252815
						20	TFP 252820
						25	TFP 252825
						30	TFP 252830
28	+0.085 -0.010	32	+0.025 0.000	28	-0.020 -0.041	20	TFP 283220
						25	TFP 283225
						30	TFP 283230
30	+0.085 -0.010	34	+0.025 0.000	30	-0.020 -0.041	15	TFP 303415
						20	TFP 303420
						25	TFP 303425
						30	TFP 303430
						40	TFP 303440
32	+0.085 -0.010	36	+0.025 0.000	32	-0.025 -0.050	20	TFP 323620
						30	TFP 323630
						40	TFP 323640
35	+0.085 -0.010	39	+0.025 0.000	35	-0.025 -0.050	20	TFP 353920
						30	TFP 353930
						35	TFP 353935
						40	TFP 353940
						50	TFP 353950
36	+0.085 -0.010	40	+0.025 0.000	36	-0.025 -0.050	15	TFP 364015
						35	TFP 364035
40	+0.085 -0.010	44	+0.025 0.000	40	-0.025 -0.050	20	TFP 404420
						30	TFP 404430
						40	TFP 404440
						50	TFP 404450
45	+0.105 -0.010	50	+0.025 0.000	45	-0.025 -0.050	20	TFP 455020
						30	TFP 455030
						40	TFP 455040
						45	TFP 455045
						50	TFP 455050

Non-standard lengths can be supplied. If the size you require is not listed please contact our sales dept. We also offer a specialised machining service for low volume non-standard sizes and tolerances. Bowman International Limited reserve the right to change specifications without prior notice E & OE



Wrapped Metric Plain Bearings. PTFE U Type

Inside Diameter When Fitted		Housing Diameter (Nominal OD)		Shaft Diameter		Length +/- 0.25	Part Number
50	+0.110 -0.010	55	+0.030 0.000	50	-0.025 -0.050	20	TFP 505520
						30	TFP 505530
						40	TFP 505540
						50	TFP 505550
						60	TFP 505560
55	+0.110 -0.010	60	+0.030 0.000	55	-0.030 -0.060	20	TFP 556020
						25	TFP 556025
						30	TFP 556030
						40	TFP 556040
						50	TFP 556050
60	+0.110 -0.010	65	+0.030 0.000	60	-0.030 -0.060	20	TFP 606520
						30	TFP 606530
						40	TFP 606540
						60	TFP 606560
						70	TFP 606570
65	+0.110 -0.010	70	+0.030 0.000	65	-0.030 -0.060	30	TFP 657030
						50	TFP 657050
						60	TFP 657060
						70	TFP 657070
70	+0.110 -0.010	75	+0.030 0.000	70	-0.030 -0.060	70	TFP 707570
75	+0.110 -0.010	80	+0.030 0.000	75	-0.030 -0.060	40	TFP 758040
						50	TFP 758050
						60	TFP 758060
						80	TFP 758080
80	+0.155 +0.020	85	+0.035 0.000	80	0.000 -0.054	60	TFP 808560
85	+0.155 +0.020	90	+0.035 0.000	85	0.000 -0.054	100	TFP 8085100
						60	TFP 859060
90	+0.155 +0.020	95	+0.035 0.000	90	0.000 -0.054	100	TFP 8590100
						60	TFP 909560
95	+0.155 +0.020	100	+0.035 0.000	95	0.000 -0.054	100	TFP 9095100
						60	TFP 9510060
100	+0.155 +0.020	105	+0.035 0.000	100	0.000 -0.054	100	TFP 95100100
						60	TFP 10010560
						70	TFP 10010570
						80	TFP 10010580
105	+0.155 +0.020	110	+0.035 0.000	105	0.000 -0.054	115	TFP 100105115
						60	TFP 10511060
110	+0.155 +0.020	115	+0.035 0.000	110	0.000 -0.054	115	TFP 105110115
						60	TFP 11011560
110	+0.155 +0.020	115	+0.035 0.000	110	0.000 -0.054	115	TFP 110115115

Inside Diameter When Fitted		Housing Diameter (Nominal OD)		Shaft Diameter		Length +/- 0.25	Part Number
115	+0.155 +0.020	120	+0.035 0.000	115	0.000 -0.054	50	TFP 11512050
						60	TFP 11512060
						70	TFP 11512070
120	+0.210 +0.070	125	+0.040 0.000	120	0.000 -0.054	60	TFP 12012560
						100	TFP 120125100
125	+0.210 +0.070	130	+0.040 0.000	125	0.000 -0.063	60	TFP 12513060
						100	TFP 125130100
130	+0.210 +0.070	135	+0.040 0.000	130	0.000 -0.063	60	TFP 13013560
						100	TFP 130135100
135	+0.210 +0.070	140	+0.040 0.000	135	0.000 -0.063	60	TFP 13514060
						100	TFP 135140100
140	+0.210 +0.070	145	+0.040 0.000	140	0.000 -0.063	60	TFP 14014560
						100	TFP 140145100
145	+0.210 +0.070	150	+0.040 0.000	145	0.000 -0.063	60	TFP 14515060
						100	TFP 145150100
150	+0.210 +0.070	155	+0.040 0.000	150	0.000 -0.063	100	TFP 150155100
						155	+0.210 +0.070
100	TFP 155160100						
160	+0.210 +0.070	165	+0.040 0.000	160	0.000 -0.063	60	TFP 16016560
						100	TFP 160165100
165	+0.210 +0.070	170	+0.040 0.000	165	0.000 -0.063	60	TFP 16517060
						100	TFP 165170100
170	+0.210 +0.070	175	+0.040 0.000	170	0.000 -0.063	60	TFP 17017560
						100	TFP 170175100
175	+0.210 +0.070	180	+0.040 0.000	175	0.000 -0.063	60	TFP 17518060
						100	TFP 175180100
180	+0.216 +0.070	185	+0.046 0.000	180	0.000 -0.063	60	TFP 18018560
						100	TFP 180185100
200	+0.216 +0.070	205	+0.046 0.000	200	0.000 -0.072	100	TFP 200205100
						210	+0.216 +0.070
220	+0.216 +0.070	225	+0.046 0.000	220	0.000 -0.072		
						100	TFP 220225100
250	+0.222 +0.070	255	+0.052 0.000	250	0.000 -0.072	60	TFP 25025560
						100	TFP 250255100
280	+0.222 +0.070	285	+0.052 0.000	280	0.000 -0.081	60	TFP 28028560
						100	TFP 280285100
300	+0.222 +0.070	305	+0.052 0.000	300	0.000 -0.081	60	TFP 30030560
						100	TFP 300305100

Non-standard lengths can be supplied. If the size you require is not listed please contact our sales dept. We also offer a specialised machining service for low volume non-standard sizes and tolerances.

Bowman International Limited reserve the right to change specifications without prior notice E & OE



Wrapped Metric Flanged Bearings. PTFE U Type

Inside Diameter When Fitted		Housing Diameter (Nominal OD)		Shaft Diameter		Flange Dia +/- 0.5	Length +/- 0.25	Part Number
6	+0.055 -0.010	8	+0.015 0.000	6	-0.010 -0.022	12	4	TFF 060412
							7	TFF 060712
							8	TFF 060812
8	+0.055 -0.010	10	+0.015 0.000	8	-0.013 -0.028	15	5.5	TFF 0805515
							7.5	TFF 0807515
							9.5	TFF 0809515
10	+0.058 -0.010	12	+0.018 0.000	10	-0.013 -0.028	18	7	TFF 100718
							9	TFF 100918
							12	TFF 101218
							17	TFF 101718
12	+0.058 -0.010	14	+0.018 0.000	12	-0.016 -0.034	20	7	TFF 120720
							9	TFF 120920
							12	TFF 121220
							17	TFF 121720
14	+0.058 -0.010	16	+0.018 0.000	14	-0.016 -0.034	22	12	TFF 141222
							17	TFF 141722
15	+0.058 -0.010	17	+0.018 0.000	15	-0.016 -0.034	23	9	TFF 150923
							12	TFF 151223
							17	TFF 151723
16	+0.058 -0.010	18	+0.018 0.000	16	-0.016 -0.034	24	12	TFF 161224
							17	TFF 161724
18	+0.061 -0.010	20	+0.021 0.000	18	-0.016 -0.034	26	12	TFF 181226
							17	TFF 181726
							22	TFF 182226
20	+0.071 -0.010	23	+0.021 0.000	20	-0.020 -0.041	30	11.5	TFF 2011530
							16.5	TFF 2016530
							21.5	TFF 2021530
25	+0.071 -0.010	28	+0.021 0.000	25	-0.020 -0.041	35	11.5	TFF 2511535
							16.5	TFF 2516535
							21.5	TFF 2521535
30	+0.085 -0.010	34	+0.025 0.000	30	-0.020 -0.041	42	16	TFF 301642
							26	TFF 302642
35	+0.085 -0.010	39	+0.025 0.000	35	-0.025 -0.050	47	16	TFF 351647
							26	TFF 352647
40	+0.085 -0.010	44	+0.025 0.000	40	-0.025 -0.050	53	16	TFF 401653
							26	TFF 402653
45	+0.105 -0.010	50	+0.025 0.000	45	-0.025 -0.050	58	16	TFF 451658
							26	TFF 452658

Non-standard lengths can be supplied. If the size you require is not listed please contact our sales dept. We also offer a specialised machining service for low volume non-standard sizes and tolerances.

Bowman International Limited reserve the right to change specifications without prior notice E & OE

Strip. PTFE U Type

Length	Width	Thickness	Part Number
500	150	0.744 0.704	TFS 07150
500	215	0.990 0.950	TFS 10200
500	245	1.510 1.470	TFS 15240
500	245	2.000 1.960	TFS 20240
500	245	2.500 2.460	TFS 25240
500	245	3.060 3.020	TFS 30240



Non-standard lengths can be supplied. If the size you require is not listed please contact our sales dept. We also offer a specialised machining service for low volume non-standard sizes and tolerances.

Bowman International Limited reserve the right to change specifications without prior notice E & OE



Washers. Metric. PTFE U Type

Inside Diameter	Outside Diameter	Thickness	Hole Dia	Hole PCD	Part Number		
10	+0.250 0.000	20	0.000 -0.250	1.50 1.45	No hole	-	TFW 1020015
12	+0.250 0.000	24	0.000 -0.250	1.50 1.45	1.90 1.60	18	TFW 1224015
14	+0.250 0.000	26	0.000 -0.250	1.50 1.45	2.40 2.10	20	TFW 1426015
16	+0.250 0.000	30	0.000 -0.250	1.50 1.45	2.40 2.10	22	TFW 1630015
18	+0.250 0.000	32	0.000 -0.250	1.50 1.45	2.40 2.10	25	TFW 1832015
20	+0.250 0.000	36	0.000 -0.250	1.50 1.45	3.40 3.10	28	TFW 2036015
22	+0.250 0.000	38	0.000 -0.250	1.50 1.45	3.40 3.10	30	TFW 2238015
24	+0.250 0.000	42	0.000 -0.250	1.50 1.45	3.40 3.10	33	TFW 2442015
26	+0.250 0.000	44	0.000 -0.250	1.50 1.45	3.40 3.10	35	TFW 2644015
28	+0.250 0.000	48	0.000 -0.250	1.50 1.45	4.40 4.10	38	TFW 2848015
32	+0.250 0.000	54	0.000 -0.250	1.50 1.45	4.40 4.10	43	TFW 3254015
38	+0.250 0.000	62	0.000 -0.250	1.50 1.45	4.40 4.10	50	TFW 3862015
42	+0.250 0.000	66	0.000 -0.250	1.50 1.45	4.40 4.10	54	TFW 4266015
48	+0.250 0.000	74	0.000 -0.250	2.00 1.95	4.40 4.10	61	TFW 487402
52	+0.250 0.000	78	0.000 -0.250	2.00 1.95	4.40 4.10	65	TFW 527802
62	+0.250 0.000	90	0.000 -0.250	2.00 1.95	4.40 4.10	76	TFW 629002
95	+0.250 0.000	115	0.000 -0.250	2.00 1.95	4.40 4.10	106	TFW 9511502

Non-standard lengths can be supplied. If the size you require is not listed please contact our sales dept. We also offer a specialised machining service for low volume non-standard sizes and tolerances.

Bowman International Limited reserve the right to change specifications without prior notice E & OE



Washers. Imperial. PTFE U Type

Inside Diameter	Outside Diameter	Thickness	Hole Dia	Hole PCD	Part Number		
1/2	+0.010 0.000	7/8	0.000 -0.010	0.063 0.061	0.077 0.067	0.692 0.682	TFWTH06
9/16	+0.010 0.000	1	0.000 -0.010	0.063 0.061	0.077 0.067	0.786 0.776	TFWTH07
5/8	+0.010 0.000	1 1/8	0.000 -0.010	0.063 0.061	0.109 0.099	0.880 0.870	TFWTH08
11/16	+0.010 0.000	1 3/16	0.000 -0.010	0.063 0.061	0.109 0.099	0.942 0.932	TFWTH09
3/4	+0.010 0.000	1 1/4	0.000 -0.010	0.063 0.061	0.109 0.099	1.005 0.995	TFWTH10
13/16	+0.010 0.000	1 3/8	0.000 -0.010	0.063 0.061	0.109 0.099	1.099 1.089	TFWTH11
7/8	+0.010 0.000	1	0.000 -0.010	0.063 0.061	0.140 0.130	1.192 1.182	TFWTH12
1	+0.010 0.000	1 3/4	0.000 -0.010	0.063 0.061	0.140 0.130	1.380 1.370	TFWTH14
1 1/8	+0.010 0.000	2	0.000 -0.010	0.063 0.061	0.171 0.161	1.567 1.557	TFWTH16
1 1/4	+0.010 0.000	2 1/8	0.000 -0.010	0.063 0.061	0.171 0.161	1.692 1.682	TFWTH18
1 3/8	+0.010 0.000	2 1/4	0.000 -0.010	0.063 0.061	0.171 0.161	1.807 1.797	TFWTH20
1 1/2	+0.010 0.000	2 1/2	0.000 -0.010	0.063 0.061	0.202 0.192	2.005 1.995	TFWTH22
1 5/8	+0.010 0.000	2 5/8	0.000 -0.010	0.063 0.061	0.202 0.192	2.130 2.120	TFWTH24
1 3/4	+0.010 0.000	2 3/4	0.000 -0.010	0.063 0.061	0.202 0.192	2.255 2.245	TFWTH26
2	+0.010 0.000	3	0.000 -0.010	0.093 0.091	0.202 0.192	2.505 2.495	TFWTH30
2 1/8	+0.010 0.000	3 1/8	-0.010 0.000	0.093 0.091	0.202 0.192	2.630 2.620	TFWTH32
2 1/4	+0.010 0.000	3 1/4	0.000 -0.010	0.093 0.091	0.202 0.192	2.755 2.745	TFWTH34



Wrapped Imperial Plain Bearings. PTFE U Type

Inside Diameter When Fitted		Housing Diameter (Nominal OD)		Shaft Diameter		L +/- 0.01	Part Number
3/16 0.1875	+0.0018 -0.0008	1/4 0.250	+0.0003 -0.0003	3/16 0.1875	-0.0010 -0.0017	3/16	TFPI03TH03
						1/4	TFPI03TH04
						3/8	TFPI03TH06
1/4 0.250	+0.0018 -0.0008	5/16 0.3125	+0.0003 -0.0003	1/4 0.250	-0.0010 -0.0019	1/4	TFPI04TH04
						3/8	TFPI04TH06
5/16 0.3125	+0.0018 -0.0008	3/8 0.375	+0.0003 -0.0003	5/16 0.3125	-0.0010 -0.0019	3/8	TFPI05TH06
						1/2	TFPI05TH08
3/8 0.375	+0.0019 -0.0008	15/32 0.4688	+0.0003 -0.0004	3/8 0.375	-0.0010 -0.0019	3/8	TFPI06TH06
						1/2	TFPI06TH08
						5/8	TFPI06TH10
						3/4	TFPI06TH12
7/16 0.4375	+0.0019 -0.0008	17/32 0.5313	+0.0003 -0.0004	7/16 0.4375	-0.0010 -0.0020	1/2	TFPI07TH08
						3/4	TFPI07TH12
1/2 0.500	+0.0019 -0.0008	19/32 0.5938	+0.0003 -0.0004	1/2 0.500	-0.0010 -0.0020	3/8	TFPI08TH06
						1/2	TFPI08TH08
						5/8	TFPI08TH10
						7/8	TFPI08TH14
9/16 0.5625	+0.0019 -0.0008	21/32 0.6563	+0.0003 -0.0004	9/16 0.5625	-0.0010 -0.0020	1/2	TFPI09TH08
						3/4	TFPI09TH12
5/8 0.625	+0.0020 -0.0008	23/32 0.7188	+0.0004 -0.0004	5/8 0.625	-0.0010 -0.0020	5/8	TFPI10TH10
						3/4	TFPI10TH12
						7/8	TFPI10TH14
11/16 0.6875	+0.0020 -0.0008	25/32 0.7813	+0.0004 -0.0004	11/16 0.6875	-0.0010 -0.0020	7/8	TFPI11TH14
3/4 0.750	+0.0025 -0.0007	7/8 0.875	+0.0005 -0.0003	3/4 0.750	-0.0009 -0.0021	1/2	TFPI12TH08
						3/4	TFPI12TH12
						1	TFPI12TH16
7/8 0.875	+0.0025 -0.0007	1 1.000	+0.0005 -0.0003	7/8 0.875	-0.0009 -0.0021	3/4	TFPI14TH12
						7/8	TFPI14TH14
						1	TFPI14TH16
1 1.000	+0.0026 -0.0008	11/8 1.125	+0.0006 -0.0004	1 1.000	-0.0009 -0.0021	3/4	TFPI16TH12
						1	TFPI16TH16
						1 1/4	TFPI16TH20
						1 1/2	TFPI16TH24
11/8 1.125	+0.0028 -0.0010	19/32 1.2813	+0.0005 -0.0005	11/8 1.125	-0.0012 -0.0024	3/4	TFPI18TH12
						1	TFPI18TH16
1 1/4 1.250	+0.0028 -0.0010	1 13/32 1.4063	+0.0005 -0.0005	1 1/4 1.250	-0.0012 -0.0028	3/4	TFPI20TH12
						1	TFPI20TH16
						1 1/4	TFPI20TH20
						1 3/4	TFPI20TH28
13/8 1.375	+0.0029 -0.0010	1 17/32 1.5313	+0.0005 -0.0005	13/8 1.375	-0.0012 -0.0028	1	TFPI22TH16
						1 3/8	TFPI22TH22
						1 3/4	TFPI22TH28

Inside Diameter When Fitted		Housing Diameter (Nominal OD)		Shaft Diameter		L +/- 0.01	Part Number
1 1/2 1.500	+0.0028 -0.0010	1 21/32 1.6563	+0.0005 -0.0005	1 1/2 1.500	-0.0012 -0.0028	1	TFPI24TH16
						1 1/4	TFPI24TH20
						1 1/2	TFPI24TH24
						2	TFPI24TH32
1 5/8 1.625	+0.0028 -0.0010	1 25/32 1.7813	+0.0005 -0.0005	1 5/8 1.625	-0.0012 -0.0028	1	TFPI26TH16
						1 1/2	TFPI26TH24
1 3/4 1.750	+0.0035 -0.0011	1 15/16 1.9375	+0.0006 -0.0004	1 3/4 1.750	-0.0013 -0.0029	1	TFPI28TH16
						1 1/2	TFPI28TH24
						1 3/4	TFPI28TH28
						2	TFPI28TH32
1 7/8 1.875	+0.0037 -0.0011	2 1/16 2.0625	+0.0008 -0.0004	1 7/8 1.875	-0.0013 -0.0029	1	TFPI30TH16
						1 7/8	TFPI30TH30
						2 1/4	TFPI30TH36
2 2.000	+0.0037 -0.0011	2 3/16 2.1875	+0.0008 -0.0004	2 2.000	-0.0013 -0.0031	1	TFPI32TH16
						1 1/2	TFPI32TH24
						2	TFPI32TH32
						2 1/2	TFPI32TH40
2 1/4 2.250	+0.0073 +0.0009	2 7/16 2.4375	+0.0002 -0.0010	2 1/4 2.250	+0.0007 -0.0011	2	TFPI36TH32
						2 1/4	TFPI36TH36
						2 1/2	TFPI36TH40
2 1/2 2.500	+0.0077 +0.0013	2 11/16 2.6875	+0.0006 -0.0006	2 1/2 2.500	+0.0011 -0.0007	2	TFPI40TH32
						2 1/2	TFPI40TH40
						3	TFPI40TH48
2 3/4 2.750	+0.0066 +0.0002	2 15/16 2.9375	-0.0005 -0.0017	2 3/4 2.750	-0.0018 0.0000	2	TFPI44TH32
						2 1/2	TFPI44TH40
						3	TFPI44TH48
						3 1/2	TFPI44TH56
3 3.000	+0.0068 +0.0002	3 3/16 3.1875	-0.0003 -0.0017	3 3.000	-0.0018 0.0000	2	TFPI48TH32
						3	TFPI48TH48
						3 3/4	TFPI48TH60
3 1/2 3.500	+0.0068 +0.0002	3 11/16 3.6875	-0.0003 -0.0017	3 1/2 3.500	-0.0022 0.0000	2 1/2	TFPI56TH40
						3	TFPI56TH48
						3 3/4	TFPI56TH60
4 4.000	+0.0068 +0.0002	4 3/16 4.1875	-0.0003 -0.0017	4 4.000	-0.0022 0.0000	3	TFPI64TH48
						3 3/4	TFPI64TH60
						4 3/4	TFPI64TH76
5 5.000	+0.0056 -0.0012	5 3/16 5.1875	-0.0015 -0.0031	5 5.000	-0.0014 -0.0039	3	TFPI80TH48
						3 3/4	TFPI80TH60
6 6.000	+0.0070 +0.0002	6 3/16 6.1875	-0.0010 -0.0017	6 6.000	-0.0025 0.0000	3	TFPI96TH48
						3 3/4	TFPI96TH60
7 7.000	+0.0026 -0.0044	7 3/16 7.1875	-0.0045 -0.0063	7 7.000	-0.0046 -0.0071	3 3/4	TFPI112TH312

Non-standard lengths can be supplied. If the size you require is not listed please contact our sales dept. We also offer a specialised machining service for low volume non-standard sizes and tolerances.

Bowman International Limited reserve the right to change specifications without prior notice E & OE



Wrapped Metric Plain Bearings. Acetal X Type

Inside Diameter When Fitted		Housing Diameter (Nominal OD)		Shaft Diameter		Oil Hole Dia	L +/- 0.25	Part Number
8	+0.108 +0.040	10	+0.018 0.000	8	0.000 -0.022	No hole	8	TPX 081008
							10	TPX 081010
							12	TPX 081012
10	+0.108 +0.040	12	+0.018 0.000	10	0.000 -0.022	4	10	TPX 101210
							12	TPX 101212
							15	TPX 101215
12	+0.108 +0.040	14	+0.018 0.000	12	0.000 -0.027	4	10	TPX 121410
							12	TPX 121412
							15	TPX 121415
							20	TPX 121420
14	+0.108 +0.040	16	+0.018 0.000	14	0.000 -0.027	4	15	TPX 141615
							20	TPX 141620
							25	TPX 141625
15	+0.108 +0.040	17	+0.018 0.000	15	0.000 -0.027	4	10	TPX 151710
							12	TPX 151712
							15	TPX 151715
							25	TPX 151725
16	+0.108 +0.040	18	+0.018 0.000	16	0.000 -0.027	4	15	TPX 161815
							20	TPX 161820
							25	TPX 161825
18	+0.131 +0.040	20	+0.021 0.000	18	0.000 -0.027	4	15	TPX 182015
							20	TPX 182020
							25	TPX 182025
20	+0.131 +0.050	23	+0.021 0.000	20	0.000 -0.033	4	10	TPX 202310
							15	TPX 202315
							20	TPX 202320
							25	TPX 202325
22	+0.131 +0.050	25	+0.021 0.000	22	0.000 -0.033	6	30	TPX 202330
							15	TPX 222515
							20	TPX 222520
							25	TPX 222525
24	+0.131 +0.050	27	+0.021 0.000	24	0.000 -0.033	6	30	TPX 222530
							15	TPX 242715
							20	TPX 242720
							25	TPX 242725
							30	TPX 242730

Inside Diameter When Fitted		Housing Diameter (Nominal OD)		Shaft Diameter		Oil Hole Dia	L +/- 0.25	Part Number
25	+0.131 +0.050	28	+0.021 0.000	25	0.000 -0.033	6	15	TPX 252815
							20	TPX 252820
							25	TPX 252825
							30	TPX 252830
28	+0.155 +0.060	32	+0.025 0.000	28	0.000 -0.033	6	20	TPX 283220
							25	TPX 283225
							30	TPX 283230
30	+0.155 +0.060	34	+0.025 0.000	30	0.000 -0.033	6	20	TPX 303420
							30	TPX 303430
							40	TPX 303440
32	+0.155 +0.060	36	+0.025 0.000	32	0.000 -0.039	6	20	TPX 323620
							30	TPX 323630
							35	TPX 323635
							40	TPX 323640
35	+0.155 +0.060	39	+0.025 0.000	35	0.000 -0.039	6	20	TPX 353920
							30	TPX 353930
							35	TPX 353935
							50	TPX 353950
40	+0.155 +0.060	44	+0.025 0.000	40	0.000 -0.039	8	20	TPX 404420
							30	TPX 404430
							40	TPX 404440
							50	TPX 404450
45	+0.195 +0.080	50	+0.025 0.000	45	0.000 -0.039	8	20	TPX 455020
							30	TPX 455030
							40	TPX 455040
							45	TPX 455045
							50	TPX 455050
50	+0.200 +0.080	55	+0.030 0.000	50	0.000 -0.039	8	40	TPX 505540
							50	TPX 505550
							60	TPX 505560
55	+0.200 +0.080	60	+0.030 0.000	55	0.000 -0.046	8	20	TPX 556020
							25	TPX 556025
							30	TPX 556030
							40	TPX 556040
							50	TPX 556050

Non-standard lengths can be supplied. If the size you require is not listed please contact our sales dept. We also offer a specialised machining service for low volume non-standard sizes and tolerances.

Bowman International Limited reserve the right to change specifications without prior notice E & OE



Wrapped Metric Plain Bearings. Acetal X Type

Inside Diameter When Fitted		Housing Diameter (Nominal OD)		Shaft Diameter		Oil Hole Dia	L +/- 0.25	Part Number	Inside Diameter When Fitted		Housing Diameter (Nominal OD)		Shaft Diameter		Oil Hole Dia	L +/- 0.25	Part Number							
60	+0.200 +0.080	65	+0.030 0.000	60	0.000 -0.046				8	30	TPX 606530	115	+0.267 +0.100	120				+0.035 0.000	115	0.000 -0.054	9.5	50	TPX 11512050	
60	+0.200 +0.080	65	+0.030 0.000	60	0.000 -0.046	40	TPX 606540	120		+0.272 +0.100	125	+0.040 0.000	120	0.000 -0.054	9.5	70	TPX 11512070							
						60	TPX 606560									60	TPX 12012560							
						70	TPX 606570									100	TPX 120125100							
65	+0.262 +0.100	70	+0.030 0.000	65	0.000 -0.046	8	50	TPX 657040	125	+0.272 +0.100	130	+0.040 0.000	125	0.000 -0.063	9.5	110	TPX 120125110							
							60	TPX 657060								60	TPX 12513060							
							70	TPX 657070								100	TPX 125130100							
70	+0.262 +0.100	75	+0.030 0.000	70	0.000 -0.046		8	25	TPX 707525	130	+0.280 +0.130	135	+0.040 0.000	130	0.000 -0.063	9.5	80	TPX 707580						
						40		TPX 707540	60								TPX 13013550							
						50		TPX 707550	80								TPX 13013580							
						60		TPX 707560	100								TPX 130135100							
						70		TPX 707570	135								+0.280 +0.130	140	+0.040 0.000	135	0.000 -0.063	9.5	60	TPX 13514060
80	TPX 707580	80	TPX 13514080																					
75	+0.262 +0.100	80	+0.030 0.000	75	0.000 -0.046	9.5	40	TPX 758040	140	+0.280 +0.130	145	+0.040 0.000	140	0.000 -0.063	9.5	50	TPX 14014550							
							60	TPX 758060								60	TPX 14014560							
							80	TPX 758080								80	TPX 14014580							
80	+0.267 +0.100	85	+0.035 0.000	80	0.000 -0.046	9.5	40	TPX 808540	145	+0.280 +0.130	150	+0.040 0.000	145	0.000 -0.063	9.5	100	TPX 140145100							
							60	TPX 808560								100	TPX 145150100							
							80	TPX 808580								150	+0.280 +0.130	155	+0.040 0.000	150	0.000 -0.063	9.5	50	TPX 15015550
							100	TPX 8085100															60	TPX 15015560
85	+0.267 +0.100	90	+0.035 0.000	85	0.000 -0.054	9.5	30	TPX 859030	160	+0.280 +0.130	165	+0.040 0.000	160	0.000 -0.063	9.5	80	TPX 15015580							
							40	TPX 859040								100	TPX 150155100							
							60	TPX 859060								160	+0.280 +0.130	165	+0.040 0.000	160	0.000 -0.063	9.5	50	TPX 16016550
							80	TPX 859080															60	TPX 16016560
							100	TPX 8590100															80	TPX 16016580
100	+0.267 +0.100	105	+0.035 0.000	100	0.000 -0.054	9.5	50	TPX 10010550	170	+0.280 +0.130	175	+0.040 0.000	170	0.000 -0.063	9.5	100	TPX 160165100							
							60	TPX 10010560								50	TPX 17017550							
							80	TPX 10010580								60	TPX 17017560							
							95	TPX 10010595								80	TPX 17017580							
							115	TPX 100105115								100	TPX 170175100							
105	+0.267 +0.100	110	+0.035 0.000	105	0.000 -0.054	9.5	60	TPX 10511060	180	+0.286 +0.130	185	+0.046 0.000	180	0.000 -0.063	9.5	50	TPX 18018550							
							115	TPX 105110115								60	TPX 18018560							
110	+0.267 +0.100	115	+0.035 0.000	110	0.000 -0.054	9.5	60	TPX 11011560	180	+0.286 +0.130	185	+0.046 0.000	180	0.000 -0.063	9.5	80	TPX 18018580							
							110	TPX 110115110								100	TPX 180185100							
							115	TPX 110115115																

Non-standard lengths can be supplied. If the size you require is not listed please contact our sales dept. We also offer a specialised machining service for low volume non-standard sizes and tolerances.

Bowman International Limited reserve the right to change specifications without prior notice E & OE



Wrapped Metric Plain Bearings. Acetal X Type

Inside Diameter When Fitted		Housing Diameter (Nominal OD)		Shaft Diameter		Oil Hole Dia	L +/- 0.25	Part Number
190	+0.286 +0.130	195	+0.046 0.000	190	0.000 -0.072	9.5	50	TPX 19019550
							60	TPX 19019560
							80	TPX 19019580
							100	TPX 190195100
							120	TPX 190195120
200	+0.286 +0.130	205	+0.046 0.000	200	0.000 -0.072	9.5	50	TPX 20020550
							60	TPX 20020560
							80	TPX 20020580
							100	TPX 200205100
							120	TPX 200205120
220	+0.286 +0.130	225	+0.046 0.000	220	0.000 -0.072	9.5	50	TPX 22022550
							60	TPX 22022560
							80	TPX 22022580
							100	TPX 220225100
							120	TPX 220225120
240	+0.286 +0.130	245	+0.046 0.000	240	0.000 -0.072	9.5	50	TPX 24024550
							60	TPX 24024560
							80	TPX 24024580
							100	TPX 240245100
							120	TPX 240245120
250	+0.292 +0.130	255	+0.052 0.000	250	0.000 -0.072	9.5	50	TPX 25025550
							60	TPX 25025560
							80	TPX 25025580
							100	TPX 250255100
							120	TPX 250255120
260	+0.292 +0.130	265	+0.052 0.000	260	0.000 -0.081	9.5	50	TPX 26026550
							60	TPX 26026560
							80	TPX 26026580
							100	TPX 260265100
							120	TPX 260265120
280	+0.292 +0.130	285	+0.052 0.000	280	0.000 -0.081	9.5	50	TPX 28028550
							60	TPX 28028560
							80	TPX 28028580
							100	TPX 280285100
							120	TPX 280285120
300	+0.292 +0.130	305	+0.052 +0.000	300	-0.000 -0.081	9.5	60	TPX 30030560
							80	TPX 30030580
							100	TPX 300305100
							120	TPX 300305120

Non-standard lengths can be supplied. If the size you require is not listed please contact our sales dept. We also offer a specialised machining service for low volume non-standard sizes and tolerances.

Bowman International Limited reserve the right to change specifications without prior notice E & OE



Wrapped Imperial Plain. Acetal X Type

Inside Diameter When Fitted		Housing Diameter (Nominal OD)		Shaft Diameter		L +/- 0.01	Part Number
3/8 0.375	-0.0054 -0.0083	15/32 0.4688	+0.0006 -0.0001	3/8 0.375	-0.0102 -0.0111	3/8	TFPI06TX06
						1/2	TFPI06TX08
						3/4	TFPI06TX12
7/16 0.4375	-0.0056 -0.0112	17/32 0.5313	+0.0006 -0.0001	7/16 0.4375	-0.0102 -0.0112	1/2	TFPI07TX08
						3/4	TFPI07TX12
1/2 0.500	-0.0083 -0.0056	19/32 0.5313	+0.0006 -0.0001	1/2 0.500	-0.0103 -0.0113	3/8	TFPI08TX06
						1/2	TFPI08TX08
						5/8	TFPI08TX10
						7/8	TFPI08TX14
9/16 0.5625	-0.0083 -0.0056	21/32 0.6563	+0.0006 -0.0001	9/16 0.5625	-0.0103 -0.0083	1/2	TFPI09TX08
						3/4	TFPI09TX12
5/8 0.625	-0.0083 -0.0055	23/32 0.7813	+0.0007 -0.0001	5/8 0.625	-0.0104 -0.0114	1/2	TFPI10TX08
						5/8	TFPI10TX10
						3/4	TFPI10TX12
						7/8	TFPI10TX14
11/16 0.625	-0.0088 -0.0055	25/32 0.7813	+0.0007 -0.0001	11/16 0.625	-0.0105 -0.0115	7/8	TFPI11TX14
3/4 0.750	-0.0088 -0.0056	7/8 0.875	+0.0010 +0.0002	3/4 0.750	-0.0110 -0.0122	1/2	TFPI12TX08
						3/4	TFPI12TX12
						1	TFPI12TX16
7/8 0.875	-0.0086 -0.0054	1 1.000	+0.0008 -0.0000	7/8 0.875	-0.0109 -0.0121	3/4	TFPI14TX12
						7/8	TFPI14TX14
						1	TFPI14TX16
1 1.000	-0.0088 -0.0056	1 1/8 1.125	+0.0008 -0.0000	1 1.000	-0.0124 -0.0121	3/4	TFPI16TX12
						1	TFPI16TX16
						1 1/2	TFPI16TX24
1 1/8 1.125	-0.0088 -0.0048	1 9/32 1.2813	+0.0008 -0.0001	1 1/8 1.125	-0.0112 -0.0124	3/4	TFPI18TX12
						1	TFPI18TX16
1 1/4 1.250	-0.0086 -0.0048	1 13/32 1.4063	+0.0009 -0.0001	1 1/4 1.250	-0.0113 -0.0129	3/4	TFPI20TX12
						1	TFPI20TX16
						1 1/4	TFPI20TX20
						1 3/4	TFPI20TX28
1 3/8 1.375	-0.0086 -0.0048	1 17/32 1.5313	+0.0009 -0.0001	1 3/8 1.375	-0.0115 -0.0131	1	TFPI22TX16
						1 3/8	TFPI22TX22
						1 3/4	TFPI22TX28

Inside Diameter When Fitted		Housing Diameter (Nominal OD)		Shaft Diameter		L +/- 0.01	Part Number
1 1/2 0.500	-0.0086 -0.0048	1 21/32 0.6563	+0.0012 -0.0002	1 1/2 0.500	-0.0116 -0.0132	1	TFPI24TX16
						1 1/4	TFPI24TX20
						1 1/2	TFPI24TX24
1 5/8 1.625	-0.0086 -0.0048	1 25/32 1.7813	+0.0009 -0.0001	1 5/8 1.625	-0.0117 -0.0133	2	TFPI24TX32
						1	TFPI26TX16
1 3/4 1.750	-0.0085 -0.0039	1 15/16 1.9375	+0.0010 -0.0000	1 3/4 1.750	-0.0107 -0.0085	1 1/2	TFPI26TX24
						1	TFPI28TX16
						1 1/2	TFPI28TX24
						1 3/4	TFPI28TX28
1 7/8 1.875	-0.0035 -0.0083	2 1/16 2.0625	+0.0012 -0.0000	1 7/8 1.875	-0.0116 -0.0132	2	TFPI29TX32
						1	TFPI30TX16
2 2.000	-0.0037 -0.0085	2 3/16 2.1875	+0.0012 -0.0000	2 2.000	-0.0120 -0.0137	1 7/8	TFPI30TX30
						2 1/4	TFPI30TX36
						1	TFPI32TX16
2 1/4 2.250	-0.0037 -0.0085	2 7/16 2.4375	+0.0012 -0.0000	2 1/4 2.240	-0.0121 -0.0140	1 1/2	TFPI32TX24
						2	TFPI32TX32
						2 1/2	TFPI32TX40
2 1/2 2.500	-0.0037 -0.0085	2 11/16 2.6875	+0.0012 -0.0000	2 1/2 2.500	-0.0125 -0.0143	2	TFPI36TX32
						2 1/2	TFPI40TX40
						2	TFPI44TX32
2 3/4 2.750	-0.0043 -0.0107	2 15/16 2.9375	+0.0012 -0.0020	2 3/4 2.750	-0.0149 -0.0167	2 1/2	TFPI44TX40
						3	TFPI44TX48
						3 1/2	TFPI44TX56
						2	TFPI44TX32
3 3.000	-0.0041 -0.0107	3 3/16 3.1875	+0.0014 -0.0000	3 3.000	-0.0151 -0.0169	3	TFPI44TX48
						3 3/4	TFPI44TX60
						2 1/2	TFPI56TX40
3 1/2 3.500	-0.0041 -0.0107	3 11/16 3.6875	+0.0014 -0.0000	3 1/2 3.500	-0.0156 -0.0178	3	TFPI56TX48
						3 3/4	TFPI56TX60
						3	TFPI64TX48
4 4.000	-0.0041 -0.0107	4 3/16 4.1875	+0.0014 -0.0003	4 4.000	-0.0161 -0.0183	3 3/4	TFPI64TX60
						4 3/4	TFPI64TX76
						3	TFPI64TX48

Non-standard lengths can be supplied. If the size you require is not listed please contact our sales dept. We also offer a specialised machining service for low volume non-standard sizes and tolerances.

Bowman International Limited reserve the right to change specifications without prior notice E & OE

Strip. Acetal X Type

Length	Width	Thickness	Part Number
460	70	1.03 1.07	TXS10070
460	100	1.52 1.56	TXS15100
460	100	2.01 2.05	TXS20100
460	100	2.52 2.57	TXS25100
500	200	3.02 3.09	TXS30200



Non-standard sizes can be supplied. If the size you require is not listed please contact our sales dept. We also offer a specialised machining service for low volume non-standard sizes and tolerances.

Bowman International Limited reserve the right to change specifications without prior notice E & OE

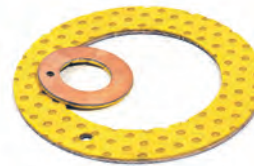

Washers. Metric. Acetal X Type

Inside Diameter	Outside Diameter	Thickness	Hole Dia	Hole PCD +/- 0.12	Part Number
12	24	1.500 1.450	1.90 1.60	18	TXW12
14	26	1.577 1.487	2.40 2.10	20	TXW14
16	30	1.577 1.487	2.40 2.10	22	TXW16
18	32	1.577 1.487	2.40 2.10	25	TXW18
20	36	1.577 1.487	3.40 3.10	28	TXW20
22	38	1.577 1.487	3.40 3.10	30	TXW22
24	42	1.577 1.487	3.40 3.10	33	TXW24
26	44	1.577 1.487	3.40 3.10	35	TXW26
28	48	1.577 1.487	4.40 4.10	38	TXW28
32	54	1.577 1.487	4.40 4.10	43	TXW32
38	62	1.577 1.487	4.40 4.10	50	TXW38
42	66	1.577 1.487	4.40 4.10	54	TXW42
48	74	2.600 2.510	4.40 4.10	61	TXW48
52	78	2.600 2.510	4.40 4.10	65	TXW52

Non-standard sizes can be supplied. If the size you require is not listed please contact our sales dept. We also offer a specialised machining service for low volume non-standard sizes and tolerances.

Bowman International Limited reserve the right to change specifications without prior notice E & OE



Washers. Imperial. Acetal X Type

Inside Diameter	Outside Diameter	Thickness	Hole Dia	Hole PCD	Part Number
1/2	7/8	0.066 0.062	0.077 0.067	0.692 0.682	TFWTX06
9/16	1	0.066 0.062	0.077 0.067	0.786 0.776	TFWTX07
5/8	1 1/8	0.066 0.062	0.077 0.067	0.786 0.776	TFWTX08
11/16	1 3/16	0.066 0.062	0.109 0.099	0.880 0.870	TFWTX09
3/4	1 1/4	0.066 0.062	0.109 0.099	1.005 0.995	TFWTX10
13/16	1 3/8	0.066 0.062	0.109 0.099	1.099 1.089	TFWTX11
7/8	1 1/2	0.066 0.062	0.140 0.120	1.192 1.182	TFWTX12
1	1 3/4	0.066 0.062	0.140 0.130	1.380 1.370	TFWTX14
1 1/8	2	0.066 0.062	0.171 0.161	1.567 1.557	TFWTX16
1 1/4	2 1/8	0.066 0.062	0.171 0.161	1.692 1.682	TFWTX18
1 3/8	2 1/4	0.066 0.062	0.171 0.161	1.817 1.807	TFWTX20
1 1/2	2 1/2	0.066 0.062	0.202 0.192	2.005 1.995	TFWTX22
1 5/8	2 5/8	0.066 0.062	0.202 0.192	2.130 2.120	TFWTX24
1 3/4	2 3/4	0.066 0.062	0.202 0.192	2.255 2.245	TFWTX26
2	3	0.097 0.093	0.202 0.192	2.505 2.495	TFWTX28
2 1/8	3 1/8	0.097 0.093	0.202 0.192	2.630 2.620	TFWTX30
2 1/4	3 1/4	0.097 0.093	0.202 0.192	2.755 2.745	TFWTX32

Non-standard sizes can be supplied. If the size you require is not listed please contact our sales dept. We also offer a specialised machining service for low volume non-standard sizes and tolerances.

Bowman International Limited reserve the right to change specifications without prior notice E & OE

Standard Wrapped Bearings



(Dimensions and tolerances to ISO 3547)

Stock range includes

- Metric plain
- Imperial plain

(Some sizes supplied to order only, minimum order quantity may apply.)

CuSn8 Wrapped Bearings



(Dimensions and tolerances to ISO 3547)

Stock range includes

- Metric plain
- Metric washers
- Metric strip
- Imperial plain
- Imperial washers
- Imperial strip

Standard Wrapped Bearings Technical Data – Summary

Static Load	150 N/mm ²
Grease Lubrication	
Max Speed	2.5m/s
Maximum PV Value	2.8N/mm ² x m/s
Coefficient of Friction	0.5 - 0.15
Oil Lubrication	
Max Speed	10m/s
Maximum PV Value	10N/mm ² x m/s
Coefficient of Friction	0.5-0.12
Max Working Temperature	
Grease Lubrication	150°C
Lubrication	250°C
Alloy Hardness	HB 60-100

CuSn8 Technical Data – Summary

Static load	120 N/mm ²
Dynamic load	40 N/mm ²
Maximum sliding speed	2.5 m/s with grease
Operating temperature	-100°C to +200°C
Intermittent maximum temperature	130°C
Thermal conductivity	60W/mK
Coefficient of friction	0.08 - 0.25
Max. PV Value	2.8 N/mm ² x m/s
Tensile Strength	450 N/mm ²
Yeild Point	250 N/mm ²
Hardness	HB 90-120
Elongation	40%

Bowman International Limited reserve the right to change specifications without prior notice. E & OE

Fitting Guidelines

1. Always use a fitting pin and fitting collar. See our fitting data sheet.
2. Lubricate back of bearing prior to assembly.
3. Chamfer lead in on housing to assist with assembly.



Metric Plain Standard Wrapped Bearings

SWB and CuSn8

Bore of Bush when in Housing		Housing Diameter		Shaft Diameter		Standard Lengths								Wall Thickness	
						10	15	20	25	30	40	50	60		
						Bush Length (+/- 0.25mm)									
10	+0.022 0.000	12	+0.018 0.000	10	-0.013 -0.028	TFPSWB 1010M	TFPSWB 1015M	TFPSWB 1020M							1.056 – 1.007
12	+0.027 0.000	14	+0.018 0.000	12	-0.016 -0.028	TFPSWB 1210M	TFPSWB 1215M	TFPSWB 1220M							1.056 – 1.007
13	+0.027 0.000	15	+0.018 0.000	13	-0.016 -0.028	TFPSWB 1310M	TFPSWB 1315M	TFPSWB 1320M	TFPSWB 1325M						1.056 – 1.007
14	+0.027 0.000	16	+0.018 0.000	14	-0.016 -0.028	TFPSWB 1410M	TFPSWB 1415M	TFPSWB 1420M	TFPSWB 1425M						1.056 – 1.007
15	+0.027 0.000	17	+0.018 0.000	15	-0.016 -0.028	TFPSWB 1510M	TFPSWB 1515M	TFPSWB 1520M	TFPSWB 1525M						1.056 – 1.007
16	+0.027 0.000	18	+0.018 0.000	16	-0.016 -0.028		TFPSWB 1615M	TFPSWB 1620M	TFPSWB 1625M						1.056 – 1.007
18	+0.027 0.000	20	+0.021 0.000	18	-0.016 -0.028		TFPSWB 1815M	TFPSWB 1820M	TFPSWB 1825M						1.056 – 1.007
19	+0.033 0.000	22	+0.021 0.000	19	-0.020 -0.041		TFPSWB 1915M		TFPSWB 1925M	TFPSWB 1930M					1.559 – 1.507
20	+0.033 0.000	23	+0.021 0.000	20	-0.020 -0.041		TFPSWB 2015M	TFPSWB 2020M	TFPSWB 2025M	TFPSWB 2030M					1.559 – 1.507
22	+0.033 0.000	25	+0.021 0.000	22	-0.020 -0.041		TFPSWB 2215M	TFPSWB 2220M	TFPSWB 2225M	TFPSWB 2230M					1.559 – 1.507
24	+0.033 0.000	27	+0.021 0.000	24	-0.020 -0.041		TFPSWB 2415M	TFPSWB 2420M	TFPSWB 2425M	TFPSWB 2430M					1.559 – 1.507
25	+0.033 0.000	28	+0.021 0.000	25	-0.020 -0.041		TFPSWB 2515M	TFPSWB 2520M	TFPSWB 2525M	TFPSWB 2530M					1.559 – 1.507
26	+0.033 0.000	30	+0.021 0.000	26	-0.020 -0.041			TFPSWB 2620M	TFPSWB 2625M	TFPSWB 2630M	TFPSWB 2640M				2.059 – 2.010
28	+0.033 0.000	32	+0.021 0.000	28	-0.020 -0.041			TFPSWB 2820M	TFPSWB 2825M	TFPSWB 2830M	TFPSWB 2840M				2.059 – 2.010
30	+0.033 0.000	34	+0.021 0.000	30	-0.020 -0.041			TFPSWB 3020M	TFPSWB 3025M	TFPSWB 3030M	TFPSWB 3040M				2.059 – 2.010
32	+0.039 0.000	36	+0.025 0.000	32	-0.025 -0.050			TFPSWB 3220M	TFPSWB 3225M	TFPSWB 3230M	TFPSWB 3240M	TFPSWB 3250M			2.059 – 2.010
34	+0.039 0.000	38	+0.025 0.000	34	-0.025 -0.050			TFPSWB 3420M	TFPSWB 3425M	TFPSWB 3430M	TFPSWB 3440M	TFPSWB 3450M			2.059 – 2.010
35	+0.039 0.000	39	+0.025 0.000	35	-0.025 -0.050			TFPSWB 3520M	TFPSWB 3525M	TFPSWB 3530M	TFPSWB 3540M	TFPSWB 3550M			2.059 – 2.010
36	+0.039 0.000	40	+0.025 0.000	36	-0.025 -0.050			TFPSWB 3620M	TFPSWB 3625M	TFPSWB 3630M	TFPSWB 3640M	TFPSWB 3650M			2.059 – 2.010
38	+0.039 0.000	42	+0.025 0.000	38	-0.025 -0.050			TFPSWB 3820M	TFPSWB 3825M	TFPSWB 3830M	TFPSWB 3840M	TFPSWB 3850M			2.059 – 2.010
40	+0.039 0.000	44	+0.025 0.000	40	-0.025 -0.050			TFPSWB 4020M	TFPSWB 4025M	TFPSWB 4030M	TFPSWB 4040M	TFPSWB 4050M			2.059 – 2.010
42	+0.039 0.000	46	+0.025 0.000	42	-0.025 -0.050			TFPSWB 4220M	TFPSWB 4225M	TFPSWB 4230M	TFPSWB 4240M	TFPSWB 4250M			2.059 – 2.010
44	+0.039 0.000	48	+0.025 0.000	44	-0.025 -0.050			TFPSWB 4420M	TFPSWB 4425M	TFPSWB 4430M	TFPSWB 4440M	TFPSWB 4450M			2.059 – 2.010
45	+0.039 0.000	50	+0.025 0.000	45	-0.025 -0.050					TFPSWB 4530M	TFPSWB 4540M	TFPSWB 4550M	TFPSWB 4560M		2.562 – 2.513
46	+0.039 0.000	51	+0.030 0.000	46	-0.025 -0.050					TFPSWB 4630M	TFPSWB 4640M	TFPSWB 4650M	TFPSWB 4660M		2.562 – 2.513
48	+0.039 0.000	53	+0.030 0.000	48	-0.025 -0.050					TFPSWB 4830M	TFPSWB 4840M	TFPSWB 4850M	TFPSWB 4860M		2.562 – 2.513
50	+0.039 0.000	55	+0.030 0.000	50	-0.025 -0.050					TFPSWB 5030M	TFPSWB 5040M	TFPSWB 5050M	TFPSWB 5060M		2.562 – 2.513
52	+0.046 0.000	57	+0.030 0.000	52	-0.030 -0.060					TFPSWB 5230M	TFPSWB 5240M	TFPSWB 5250M	TFPSWB 5260M		2.562 – 2.513
55	+0.046 0.000	60	+0.030 0.000	55	-0.030 -0.060					TFPSWB 5530M	TFPSWB 5540M	TFPSWB 5550M	TFPSWB 5560M		2.562 – 2.513
58	+0.046 0.000	63	+0.030 0.000	58	-0.030 -0.060					TFPSWB 5830M	TFPSWB 5840M	TFPSWB 5850M	TFPSWB 5860M		2.562 – 2.513

No oil hole or oil groove is present in metric size.

Non-standard sizes can be supplied. If the size you require is not listed please contact our sales dept. We also offer a specialised machining service for low volume non-standard sizes and tolerances.

Bowman International Limited reserve the right to change specifications without prior notice E & OE



Imperial Plain Standard Wrapped Bearings

Bore of Bush when in Housing		Housing Diameter		Shaft Diameter		Standard Lengths													Wall Thickness	
						3/8	1/2	5/8	3/4	7/8	1	1 1/4	1 1/2	1 3/4	2	2 1/4	2 1/2	2 3/4		3
						5/32 Oil Hole diameter				1/4 Oil Hole diameter		1/4 or 5/16 Oil Hole			1/4 or 3/8 Oil Hole	3/8 Oil Hole diameter				
3/8	+0.009 0.000	15/32	+0.010 0.000	3/8	-0.010 -0.019	TFPSWB 1203	TFPSWB 1204	TFPSWB 2305	TFPSWB 1206											0.049 - 0.047
7/16	+0.010 0.000	17/32	+0.010 0.000	7/16	-0.012 -0.022	TFPSWB 1403	TFPSWB 1404		TFPSWB 1406											0.049 - 0.047
1/2	+0.010 0.000	19/32	+0.010 0.000	1/2	-0.012 -0.022	TFPSWB 1603	TFPSWB 1604	TFPSWB 1605	TFPSWB 1606	TFPSWB 1607										0.049 - 0.047
9/16	+0.010 0.000	21/32	+0.010 0.000	9/16	-0.012 -0.022		TFPSWB 1804	TFPSWB 1805	TFPSWB 1806	TFPSWB 1807										0.049 - 0.047
5/8	+0.010 0.000	23/32	+0.010 0.000	5/8	-0.012 -0.022	TFPSWB 2003	TFPSWB 2004	TFPSWB 2005	TFPSWB 2006	TFPSWB 2007	TFPSWB 2008									0.049 - 0.047
11/16	+0.010 0.000	25/32	+0.012 0.000	11/16	-0.012 -0.022			TFPSWB 2205	TFPSWB 2206	TFPSWB 2207										0.049 - 0.047
3/4	+0.012 0.000	7/8	+0.012 0.000	3/4	-0.016 -0.028		TFPSWB 2404	TFPSWB 2405	TFPSWB 2406		TFPSWB 2408	TFPSWB 2410								0.065 - 0.063
13/16	+0.012 0.000	15/16	+0.012 0.000	13/16	-0.016 -0.028				TFPSWB 2606		TFPSWB 2608									0.065 - 0.063
7/8	+0.012 0.000	1	+0.012 0.000	7/8	-0.016 -0.065		TFPSWB 2804		TFPSWB 2806		TFPSWB 2808	TFPSWB 2810								0.065 - 0.063
15/16	+0.012 0.000	1 1/16	+0.012 0.000	15/16	-0.064 -0.065		TFPSWB 3004		TFPSWB 3006		TFPSWB 2008	TFPSWB 3010								0.065 - 0.063
1	+0.012 0.000	1 1/8	+0.012 0.000	1	-0.064 -0.065		TFPSWB 3204		TFPSWB 3206		TFPSWB 3208	TFPSWB 3210	TFPSWB 3212							0.065 - 0.063
1 1/8	+0.012 0.000	19/32	+0.016 0.000	1 1/8	-0.126 -0.127				TFPSWB 3606		TFPSWB 3608	TFPSWB 3610	TFPSWB 3612							0.080 - 0.078
1 1/4	+0.016 0.000	1 13/32	+0.016 0.000	1 1/4	-0.126 -0.127				TFPSWB 4006		TFPSWB 4008	TFPSWB 4010	TFPSWB 4012	TFPSWB 4014						0.080 - 0.078
1 3/8	+0.016 0.000	1 17/32	+0.016 0.000	1 3/8	-0.127 -0.128				TFPSWB 4406		TFPSWB 4408	TFPSWB 4410	TFPSWB 4412	TFPSWB 4414						0.080 - 0.078
1 1/2	+0.016 0.000	1 21/32	+0.016 0.000	1 1/2	-0.127 -0.128				TFPSWB 4806		TFPSWB 4808	TFPSWB 4810	TFPSWB 4812	TFPSWB 4814	TFPSWB 4816					0.080 - 0.078
1 5/8	+0.016 0.000	1 25/32	+0.016 0.000	1 5/8	-0.127 -0.128				TFPSWB 5206		TFPSWB 5208	TFPSWB 5210	TFPSWB 5212	TFPSWB 5214	TFPSWB 5216					0.080 - 0.078
1 3/4	+0.016 0.000	1 15/16	+0.016 0.000	1 3/4	-0.002 -0.003						TFPSWB 5608	TFPSWB 5610*	TFPSWB 5612*	TFPSWB 5614*	TFPSWB 5616*					0.096 - 0.094
1 7/8	+0.016 0.000	2 1/16	+0.018 0.000	1 7/8	-0.002 -0.003						TFPSWB 6008	TFPSWB 6010*	TFPSWB 6012*	TFPSWB 6014*	TFPSWB 6016*	TFPSWB 6018				0.096 - 0.094
2	+0.018 0.000	2 3/16	+0.018 0.000	2	-0.002 -0.004						TFPSWB 6408	TFPSWB 6410*	TFPSWB 6412*	TFPSWB 6414*	TFPSWB 6416*	TFPSWB 6418	TFPSWB 6420			0.096 - 0.094
2 1/4	+0.018 0.000	2 7/16	+0.018 0.000	2 1/4	-0.002 -0.004						TFPSWB 7208	TFPSWB 7210	TFPSWB 7212*	TFPSWB 7214*	TFPSWB 7216*	TFPSWB 7218	TFPSWB 7220			0.096 - 0.094
2 1/2	+0.018 0.000	2 11/16	+0.018 0.000	2 1/2	-0.002 -0.004							TFPSWB 8010*	TFPSWB 8012*	TFPSWB 8014*	TFPSWB 8016*	TFPSWB 8018	TFPSWB 8020	TFPSWB 8022		0.096 - 0.094
2 3/4	+0.018 0.000	2 15/16	+0.018 0.000	2 3/4	-0.002 -0.004										TFPSWB 8816*	TFPSWB 8818	TFPSWB 8820	TFPSWB 8822	TFPSWB 8824	0.096 - 0.094
3	+0.018 0.000	3 3/16	+0.018 0.000	3	-0.002 -0.004										TFPSWB 9616*	TFPSWB 9618	TFPSWB 9620	TFPSWB 9622	TFPSWB 9624	0.096 - 0.094

* denotes larger of the 2 oil holes quoted.

Lining thickness as supplied: 0.03 minimum

Non-standard sizes can be supplied. If the size you require is not listed please contact our sales dept. We also offer a specialised machining service for low volume non-standard sizes and tolerances.

Bowman International Limited reserve the right to change specifications without prior notice E & OE



Metric Plain Wrapped Bronze CuSn8

Bore of Bush when in Housing	Housing Diameter H7	Shaft Diameter	Standard Lengths														
			10	15	20	25	30	40	50	60	70	80					
			ID < 80 Length +/- 0.25						ID > 80 Length +/- 0.50								
10	+0.043 0.000	12	+0.018 0.000	10	-0.013 -0.028	BFP 101210	BFP 101215	BFP 101220									
12	+0.043 0.000	14	+0.018 0.000	12	-0.016 -0.034	BFP 121410	BFP 121415	BFP 121420									
14	+0.043 0.000	16	+0.018 0.000	14	-0.016 -0.034	BFP 141610	BFP 141615	BFP 141620	BFP 141625								
15	+0.043 0.000	17	+0.018 0.000	15	-0.016 -0.034	BFP 151710	BFP 151715	BFP 151720	BFP 151725								
16	+0.043 0.000	18	+0.018 0.000	16	-0.016 -0.034	BFP 161810	BFP 161815	BFP 161820	BFP 161825								
18	+0.043 0.000	20	+0.018 0.000	18	-0.016 -0.034	BFP 182010	BFP 182015	BFP 182020	BFP 182025								
20	+0.052 0.000	23	+0.021 0.000	20	-0.020 -0.041	BFP 202310	BFP 202315	BFP 202320	BFP 202325	BFP 202330							
22	+0.052 0.000	25	+0.021 0.000	22	-0.020 -0.041	BFP 222510	BFP 222515	BFP 222520	BFP 222525	BFP 222530							
24	+0.052 0.000	27	+0.021 0.000	24	-0.020 -0.041		BFP 242715	BFP 242720	BFP 242725	BFP 242730							
25	+0.052 0.000	28	+0.021 0.000	25	-0.020 -0.041		BFP 252815	BFP 252820	BFP 252825	BFP 252830							
28	+0.052 0.000	32	+0.021 0.000	28	-0.020 -0.041		BFP 283215	BFP 283220	BFP 283225	BFP 283230							
30	+0.052 0.000	34	+0.021 0.000	30	-0.020 -0.041		BFP 303415	BFP 303420	BFP 303425	BFP 303430	BFP 303440						
32	+0.062 0.000	36	+0.025 0.000	32	-0.025 -0.050		BFP 323615	BFP 323620	BFP 323625	BFP 323630	BFP 323640	BFP 323650					
35	+0.062 0.000	39	+0.025 0.000	35	-0.025 -0.050		BFP 353915	BFP 353920	BFP 353925	BFP 353930	BFP 353940	BFP 353950					
40	+0.062 0.000	44	+0.025 0.000	40	-0.025 -0.050			BFP 404420	BFP 404425	BFP 404430	BFP 404440	BFP 404450					
45	+0.062 0.000	50	+0.025 0.000	45	-0.025 -0.050			BFP 455020	BFP 455025	BFP 455030	BFP 455040	BFP 455050					
50	+0.062 0.000	55	+0.025 0.000	50	-0.025 -0.050			BFP 505520	BFP 505525	BFP 505530	BFP 505540	BFP 505550	BFP 505560				
55	+0.074 0.000	60	+0.030 0.000	55	-0.030 -0.060			BFP 556020	BFP 556025	BFP 556030	BFP 556040	BFP 556050	BFP 556060				
60	+0.074 0.000	65	+0.030 0.000	60	-0.030 -0.060				BFP 606525	BFP 606530	BFP 606540	BFP 606550	BFP 606560	BFP 606570			
65	+0.074 0.000	70	+0.030 0.000	65	-0.030 -0.060					BFP 657030	BFP 657040	BFP 657050	BFP 657060	BFP 657070	BFP 657080		
70	+0.074 0.000	75	+0.030 0.000	70	-0.030 -0.060					BFP 707530	BFP 707540	BFP 707550	BFP 707560	BFP 707570	BFP 707580		
75	+0.074 0.000	80	+0.030 0.000	75	-0.030 -0.060					BFP 758030	BFP 758040	BFP 758050	BFP 758060	BFP 758070	BFP 758080		
80	+0.074 0.000	85	+0.030 0.000	80	-0.030 -0.060					BFP 808530	BFP 808540	BFP 808550	BFP 808560	BFP 808570	BFP 808580		

Non-standard sizes can be supplied. If the size you require is not listed please contact our sales dept. We also offer a specialised machining service for low volume non-standard sizes and tolerances.

Bowman International Limited reserve the right to change specifications without prior notice E & OE



Metric Plain Wrapped Bronze CuSn8

Bore of Bush when in Housing		Housing Diameter		Shaft Diameter		Standard Lengths							
						30	40	50	60	70	80	90	100
						ID < 80 Length +/- 0.25				ID > 80 Length +/- 0.50			
85	+0.087 0.000	90	+0.035 0.000	85	-0.036 -0.071	BFP 859030	BFP 859040	BFP 859050	BFP 859060	BFP 859070	BFP 859080		
90	+0.087 0.000	95	+0.035 0.000	90	-0.036 -0.071	BFP 909530	BFP 909540	BFP 909550	BFP 909560	BFP 909570	BFP 909580		
95	+0.087 0.000	100	+0.035 0.000	95	-0.036 -0.071		BFP 9510040	BFP 9510050	BFP 9510060	BFP 9510070	BFP 9510080	BFP 9510090	BFP 9510100
100	+0.087 0.000	105	+0.035 0.000	100	-0.036 -0.071			BFP 10010550	BFP 10010560	BFP 10010570	BFP 10010580	BFP 10010590	BFP 10010600
105	+0.087 0.000	110	+0.035 0.000	105	-0.036 -0.071			BFP 10511050	BFP 10511060	BFP 10511070	BFP 10511080	BFP 10511090	BFP 10511100
110	+0.087 0.000	115	+0.035 0.000	110	-0.036 -0.071			BFP 11011550	BFP 11011560	BFP 11011570	BFP 11011580	BFP 11011590	BFP 11011600
115	+0.087 0.000	120	+0.035 0.000	115	-0.036 -0.071			BFP 11512050	BFP 11512060	BFP 11512070	BFP 11512080	BFP 11512090	BFP 11512100
120	+0.087 0.000	125	+0.035 0.000	120	-0.036 -0.071				BFP 12012560	BFP 12012570	BFP 12012580	BFP 12012590	BFP 12012600
125	+0.100 0.000	130	+0.040 0.000	125	-0.043 -0.083				BFP 12513060	BFP 12513070	BFP 12513080	BFP 12513090	BFP 12513100
130	+0.100 0.000	135	+0.040 0.000	130	-0.043 -0.083				BFP 13013560	BFP 13013570	BFP 13013580	BFP 13013590	BFP 13013600
135	+0.100 0.000	140	+0.040 0.000	135	-0.043 -0.083				BFP 13514060	BFP 13514070	BFP 13514080	BFP 13514090	BFP 13514100
140	+0.100 0.000	145	+0.040 0.000	140	-0.043 -0.083				BFP 14014560	BFP 14014570	BFP 14014580	BFP 14014590	BFP 14014600
145	+0.100 0.000	150	+0.040 0.000	145	-0.043 -0.083				BFP 14515060	BFP 14515070	BFP 14515080	BFP 14515090	BFP 14515100
150	+0.100 0.000	155	+0.040 0.000	150	-0.043 -0.083				BFP 15015560	BFP 15015570	BFP 15015580	BFP 15015590	BFP 15015600
155	+0.100 0.000	160	+0.040 0.000	155	-0.043 -0.083				BFP 15516060	BFP 15516070	BFP 15516080	BFP 15516090	BFP 15516100
160	+0.100 0.000	165	+0.040 0.000	160	-0.043 -0.083				BFP 16016560	BFP 16016570	BFP 16016580	BFP 16016590	BFP 16016600
165	+0.100 0.000	170	+0.040 0.000	165	-0.043 -0.083				BFP 16517060	BFP 16517070	BFP 16517080	BFP 16517090	BFP 16517100
170	+0.100 0.000	175	+0.040 0.000	170	-0.043 -0.083				BFP 17017560	BFP 17017570	BFP 17017580	BFP 17017590	BFP 17017600
175	+0.100 0.000	180	+0.040 0.000	175	-0.043 -0.083				BFP 17518060	BFP 17518070	BFP 17518080	BFP 17518090	BFP 17518100
180	+0.100 0.000	185	+0.040 0.000	180	-0.043 -0.083				BFP 18018560	BFP 18018570	BFP 18018580	BFP 18018590	BFP 18018600
185	+0.115 0.000	190	+0.046 0.000	185	-0.050 -0.096				BFP 18519060	BFP 18519070	BFP 18519080	BFP 18519090	BFP 18519100
190	+0.115 0.000	195	+0.046 0.000	190	-0.050 -0.096				BFP 19019560	BFP 19019570	BFP 19019580	BFP 19019590	BFP 19019600
195	+0.115 0.000	200	+0.046 0.000	195	-0.050 -0.096				BFP 19520060	BFP 19520070	BFP 19520080	BFP 19520090	BFP 19520100
200	+0.115 0.000	205	+0.046 0.000	200	-0.050 -0.096				BFP 20020560	BFP 20020570	BFP 20020580	BFP 20020590	BFP 20020600
205	+0.115 0.000	210	+0.046 0.000	205	-0.050 -0.096				BFP 20521060	BFP 20521070	BFP 20521080	BFP 20521090	BFP 20521100
215	+0.115 0.000	220	+0.046 0.000	215	-0.050 -0.096				BFP 21522060	BFP 21522070	BFP 21522080	BFP 21522090	BFP 21522100
220	+0.115 0.000	225	+0.046 0.000	220	-0.050 -0.096				BFP 22022560	BFP 22022570	BFP 22022580	BFP 22022590	BFP 22022600
225	+0.115 0.000	230	+0.046 0.000	225	-0.050 -0.096				BFP 22523060	BFP 22523070	BFP 22523080	BFP 22523090	BFP 22523100
230	+0.115 0.000	235	+0.046 0.000	230	-0.050 -0.096				BFP 23023560	BFP 23023570	BFP 23023580	BFP 23023590	BFP 23023600
240	+0.115 0.000	245	+0.046 0.000	240	+0.050 +0.096				BFP 24024060	BFP 24024070	BFP 24024080	BFP 24024090	BFP 24024100
250	+0.115 0.000	255	+0.046 0.000	250	+0.050 +0.096				BFP 25024560	BFP 25024570	BFP 25024580	BFP 25024590	BFP 25024600
260	+0.130 0.000	265	+0.052 0.000	260	+0.056 +0.108				BFP 26025060	BFP 26025070	BFP 26025080	BFP 26025090	BFP 26025100
270	+0.130 0.000	275	+0.052 0.000	270	+0.056 +0.108				BFP 27025560	BFP 27025570	BFP 27025580	BFP 27025590	BFP 27025600
280	+0.130 0.000	285	+0.052 0.000	280	+0.056 +0.108				BFP 28026060	BFP 28026070	BFP 28026080	BFP 28026090	BFP 28026100
290	+0.130 0.000	295	+0.052 0.000	290	+0.056 +0.108				BFP 29026560	BFP 29026570	BFP 29026580	BFP 29026590	BFP 29026600
300	+0.130 0.000	305	+0.052 0.000	300	+0.056 +0.108				BFP 30027060	BFP 30027070	BFP 30027080	BFP 30027090	BFP 30027100

Non-standard sizes can be supplied. If the size you require is not listed please contact our sales dept. We also offer a specialised machining service for low volume non-standard sizes and tolerances.

Bowman International Limited reserve the right to change specifications without prior notice E & OE



Metric Flanged Wrapped Bronze CuSn8

Bore of Bush when in Housing	Housing Diameter		Shaft Diameter		Flange Dia	Standard Lengths										
						5	10	15	20	25	30	35	40	50	60	
						ID < 80 Length +/- 0.25					ID > 80 Length +/- 0.50					
25	+0.052 0.000	28	+0.021 0.000	25	-0.020 -0.041	35			BFF 251535	BFF 252035	BFF 252535	BFF 253035				
30	+0.052 0.000	34	+0.025 0.000	30	-0.020 -0.041	45			BFF 302045	BFF 302545	BFF 303045	BFF 303545				
35	+0.062 0.000	39	+0.025 0.000	35	-0.025 -0.050	50			BFF 352050	BFF 352550	BFF 353050	BFF 353550				
40	+0.062 0.000	44	+0.025 0.000	40	-0.025 -0.050	55				BFF 402555	BFF 403055	BFF 403555	BFF 404055			
45	+0.062 0.000	50	+0.025 0.000	45	-0.025 -0.050	60					BFF 453060	BFF 453560	BFF 454060	BFF 455060		
50	+0.062 0.000	55	+0.030 0.000	50	-0.025 -0.050	65					BFF 503065	BFF 503565	BFF 504065	BFF 505065		
55	+0.074 0.000	60	+0.030 0.000	55	-0.030 -0.060	70					BFF 553070	BFF 553570	BFF 554070	BFF 555070		
60	+0.074 0.000	65	+0.030 0.000	60	-0.030 -0.060	75					BFF 603075	BFF 603575	BFF 604075	BFF 605075	BFF 606075	
65	+0.074 0.000	70	+0.030 0.000	65	-0.030 -0.060	80					BFF 653080	BFF 653580	BFF 654080	BFF 655080	BFF 656080	

Non-standard sizes can be supplied. If the size you require is not listed please contact our sales dept. We also offer a specialised machining service for low volume non-standard sizes and tolerances.

Bowman International Limited reserve the right to change specifications without prior notice E & OE

Bore of Bush when in Housing	Housing Diameter		Shaft Diameter		Flange Dia	Standard Lengths									
						35	40	50	60	70	80	90			
						ID < 80 Length +/- 0.25					ID > 80 Length +/- 0.50				
70	+0.074 0.000	75	+0.030 0.000	70	-0.030 -0.060	85	BFF 703585	BFF 704085	BFF 705085	BFF 706085	BFF 707085				
75	+0.074 0.000	80	+0.030 0.000	75	-0.030 -0.060	90	BFF 753590	BFF 754090	BFF 755090	BFF 756090	BFF 757090				
80	+0.074 0.000	85	+0.035 0.000	80	-0.030 -0.060	100		BFF 8040100	BFF 8050100	BFF 8060100	BFF 8070100	BFF 8080100			
90	+0.087 0.000	95	+0.035 0.000	90	-0.036 -0.071	110			BFF 9050110	BFF 9060110	BFF 9070110	BFF 9080110	BFF 9090110		
100	+0.087 0.000	105	+0.035 0.000	100	-0.036 -0.071	120			BFF 10050120	BFF 10060120	BFF 10070120	BFF 10080120	BFF 10090120		
110	+0.087 0.000	115	+0.035 0.000	110	-0.036 -0.071	130			BFF 11050130	BFF 11060130	BFF 11070130	BFF 11080130	BFF 11090130		
120	+0.087 0.000	125	+0.040 0.000	120	-0.036 -0.071	140				BFF 12060140	BFF 12070140	BFF 12080140	BFF 12090140		
130	+0.100 0.000	135	+0.040 0.000	130	-0.043 -0.083	155				BFF 13060155	BFF 13070155	BFF 13080155	BFF 13090155		
140	+0.100 0.000	145	+0.040 0.000	140	-0.043 -0.083	165				BFF 14060165	BFF 14070165	BFF 14080165	BFF 14090165		
150	+0.100 0.000	155	+0.040 0.000	150	-0.043 -0.083	180				BFF 15060180	BFF 15070180	BFF 15080180	BFF 15090180		
160	+0.100 0.000	165	+0.040 0.000	160	-0.043 -0.083	190				BFF 16060190	BFF 16070190	BFF 16080190	BFF 16090190		
170	+0.100 0.000	175	+0.040 0.000	170	-0.043 -0.083	200				BFF 17060200	BFF 17070200	BFF 17080200	BFF 17090200		
180	+0.100 0.000	185	+0.046 0.000	180	-0.043 -0.083	215				BFF 18060215	BFF 18070215	BFF 18080215	BFF 18090215		
190	+0.115 0.000	195	+0.046 0.000	190	-0.050 -0.096	225				BFF 19060225	BFF 19070225	BFF 19080225	BFF 19090225		
200	+0.115 0.000	205	+0.046 0.000	200	-0.050 -0.096	235				BFF 20060235	BFF 20070235	BFF 20080235	BFF 20090235		
225	+0.115 0.000	230	+0.046 0.000	225	-0.050 -0.096	260				BFF 22560260	BFF 22570260	BFF 22580260	BFF 22590260		
250	+0.115 0.000	255	+0.052 0.000	250	-0.050 -0.096	290				BFF 25060290	BFF 25070290	BFF 25080290	BFF 25090290		
265	+0.130 0.000	270	+0.052 0.000	265	-0.056 -0.108	305				BFF 26560305	BFF 26570305	BFF 26580305	BFF 26590305		
285	+0.130 0.000	290	+0.052 0.000	285	-0.056 -0.108	325				BFF 28560325	BFF 28570325	BFF 28580325	BFF 28590325		
300	+0.130 0.000	305	+0.052 0.000	300	-0.056 -0.108	340				BFF 30060340	BFF 30070340	BFF 30080340	BFF 30090340		

Non-standard sizes can be supplied. If the size you require is not listed please contact our sales dept. We also offer a specialised machining service for low volume non-standard sizes and tolerances.

Bowman International Limited reserve the right to change specifications without prior notice E & OE

Recommended Fitting Instructions for Plain and Flanged Wrapped Bearings

Bearing ID Below 55mm

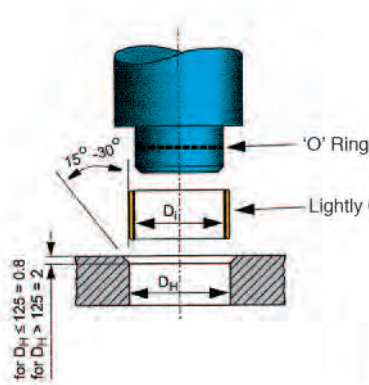

Bearing ID Above 55mm

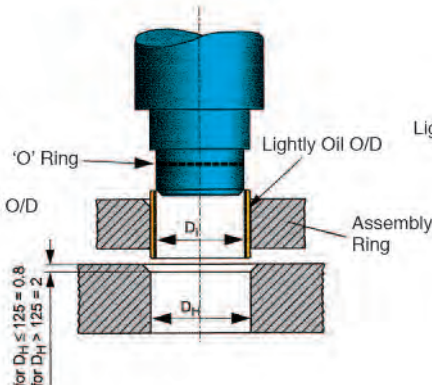

Bearing ID Below 120mm

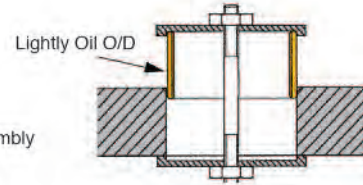

Fitting of Flanged Bearings

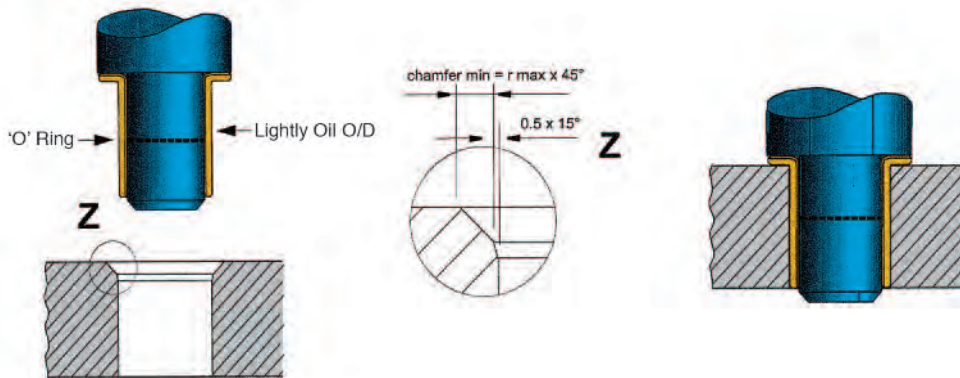

Assembly Forces Required

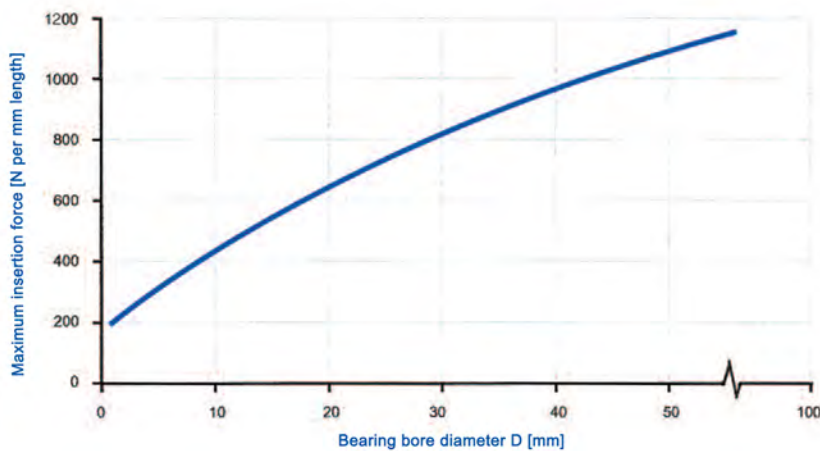

Max Assembly Forces

Please note that oiling the OD, the amount of interference, the surface finish of the housing and the lead in chamfer on the bore in the housing, can have a considerable effect on the forces required.

Cast bronze bearings with solid graphite lubrication

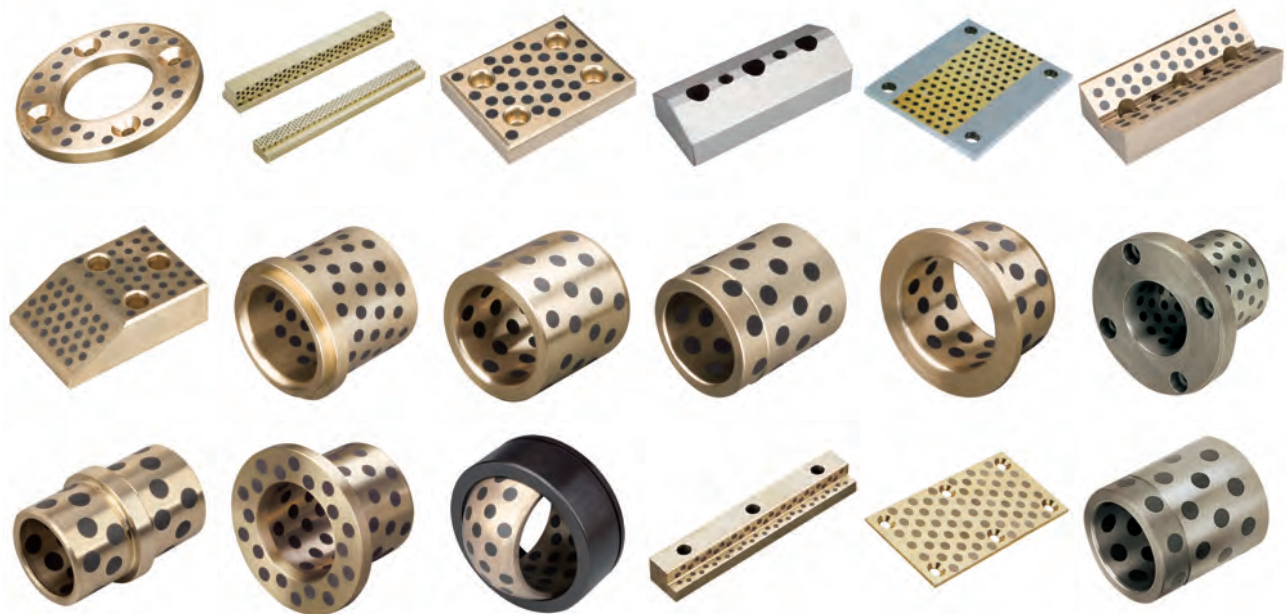

All these bearings are made to order. Other shapes can be offered.

Graphite loaded bearings can withstand very high temperatures up to 425 °C (800 °F) as well as cryogenic temperatures down to -200°C (-400 °F) depending on the bronze material and graphite selected. This makes them ideal where conventional lubricants would carbonise. Please contact our technical department to ascertain which would be the most suitable combination to suit your application.

Typical applications are ovens, kilns, dryers, injection moulding machines, dust collectors, louvers and hot conveyors.

These bearings are also ideal in dry environments where contamination is undesirable. Typical applications would be printing, textile, and food machinery, as well as machines for making pills and cosmetic products.

They are also used extensively for wet applications where there is high humidity, or in submersed pumps, textile finishing machinery, lock gates, water turbines, chemical processing and plating applications.

This type of bearing is also useful where the bearings are in an inaccessible location, as they are lubricated for life.

Technical Data

Standard Material	Cu 65%, Zn 25%, Al 6%, Mn 4%
Density	8 g/cm ³
Hardness	> 210 HB
Tensile Strength	750 N/mm ²
Elongation	> 12%
Linear Expansion	1.9 – 10 ⁻⁵ / °C
Max Temp	300 °C (570 °F)
Static Load	100 N/mm ²
Max Speed	15 m/s
PV	200 N/mm ² s m/s

Other cast bronze materials/specifications are available which can operate up to 425 °C.

Different shapes can be manufactured to suit customer requirements.

Bowman International Limited reserve the right to change specifications without prior notice E & OE



Metric Plain cast bronze bearings with solid graphite lubrication

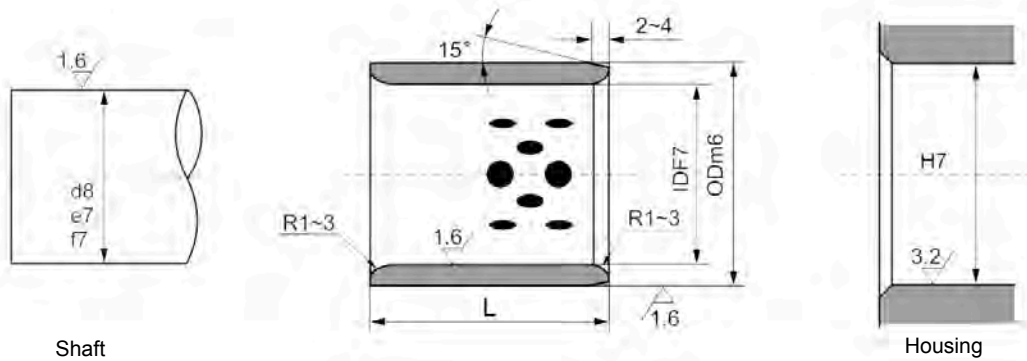

Outside Diameter m6	Inside Diameter F7	Standard Lengths -0.10/-0.30mm															
		8	10	12	15	16	20	25	30	35	40	50	60	70	80		
8	+0.028 +0.013	12	+0.018 +0.007	GRP 081208	GRP 081210	GRP 081212	GRP 081215										
10	+0.028 +0.013	14	+0.018 +0.007	GRP 101408	GRP 101410	GRP 101412	GRP 101415		GRP 101420								
12	+0.034 +0.016	18	+0.018 +0.007		GRP 121810	GRP 121812	GRP 121815	GRP 121816	GRP 121820	GRP 121825	GRP 121830						
13	+0.034 +0.016	19	+0.021 +0.008		GRP 131910		GRP 131915	GRP 131916									
14	+0.034 +0.016	20	+0.021 +0.008		GRP 142010	GRP 142012	GRP 142015		GRP 142020	GRP 142025	GRP 142030						
15	+0.034 +0.016	21	+0.021 +0.008		GRP 152110	GRP 152112	GRP 152115	GRP 152116	GRP 152120	GRP 152125	GRP 152130						
16	+0.034 +0.016	22	+0.021 +0.008		GRP 162210	GRP 162212	GRP 162215	GRP 162216	GRP 162220	GRP 162225	GRP 162230	GRP 162235	GRP 162240				
18	+0.034 +0.016	24	+0.021 +0.008			GRP 182412	GRP 182415	GRP 182416	GRP 182420	GRP 182425	GRP 182430	GRP 182435	GRP 182440				
20	+0.041 +0.020	28	+0.021 +0.008		GRP 202810	GRP 202812	GRP 202815	GRP 202816	GRP 202820	GRP 202825	GRP 202830	GRP 202835	GRP 202840	GRP 202850			
22	+0.041 +0.020	32	+0.025 +0.009			GRP 223212	GRP 223215		GRP 223220	GRP 223225							
25	+0.041 +0.020	33	+0.025 +0.009			GRP 253312	GRP 253315	GRP 253316	GRP 253320	GRP 253325	GRP 253330	GRP 253335	GRP 253340	GRP 253350	GRP 253360		
30	+0.041 +0.020	38	+0.025 +0.009			GRP 303812	GRP 303815		GRP 303820	GRP 303825	GRP 303830	GRP 303835	GRP 303840	GRP 303850	GRP 303860		
35	+0.050 +0.025	45	+0.025 +0.009						GRP 354520	GRP 354525	GRP 354530	GRP 354535	GRP 354540	GRP 354550	GRP 354560		
40	+0.050 +0.025	50	+0.025 +0.009						GRP 405020	GRP 405025	GRP 405030	GRP 405035	GRP 405040	GRP 405050	GRP 405060	GRP 405070	GRP 405080
45	+0.050 +0.025	55	+0.030 +0.011								GRP 455530	GRP 455535	GRP 455540	GRP 455550	GRP 455560		
50	+0.050 +0.025	60	+0.030 +0.011								GRP 506030	GRP 506035	GRP 506040	GRP 506050	GRP 506060	GRP 506070	GRP 506080
50	+0.050 +0.025	62	+0.030 +0.011								GRP 506230	GRP 506235	GRP 506240	GRP 506250	GRP 506260	GRP 506270	

Non-standard sizes can be supplied. If the size you require is not listed please contact our sales dept. We also offer a specialised machining service for low volume non-standard sizes and tolerances.

Bowman International Limited reserve the right to change specifications without prior notice E & OE



Metric Plain cast bronze bearings with solid graphite lubrication

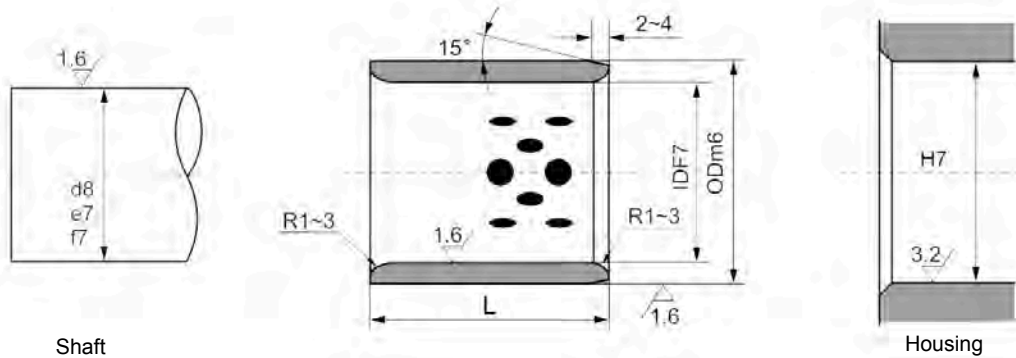

Outside Diameter m6	Inside Diameter F7	30	35	40	50	60	70	80	100	120	130	140	150
		Standard Lengths -0.10/-0.30mm											
50	+0.050 +0.025	65	+0.030 +0.011	GRP 506530		GRP 506540	GRP 506550	GRP 506560	GRP 506570	GRP 506580			
55	+0.060 +0.030	70	+0.030 +0.011			GRP 557040	GRP 557050	GRP 557060	GRP 557070				
60	+0.060 +0.030	74	+0.030 +0.011	GRP 607430	GRP 607435	GRP 607440	GRP 607450	GRP 607460	GRP 607470	GRP 607480			
60	+0.060 +0.030	75	+0.030 +0.011	GRP 607530	GRP 607535	GRP 607540	GRP 607550	GRP 607560	GRP 607570	GRP 607580	GRP 6075100		
63	+0.060 +0.030	75	+0.030 +0.011					GRP 637560	GRP 637570	GRP 637580			
65	+0.060 +0.036	80	+0.030 +0.011			GRP 658050	GRP 658060	GRP 658070	GRP 658080				
70	+0.060 +0.030	85	+0.035 +0.013		GRP 708535	GRP 708540	GRP 708550	GRP 708560	GRP 708570	GRP 708580	GRP 7085100		
70	+0.060 +0.030	90	+0.035 +0.013			GRP 709050	GRP 709060	GRP 709070	GRP 709080				
75	+0.060 +0.030	90	+0.035 +0.013				GRP 759060	GRP 759070	GRP 759080	GRP 7590100			
75	+0.060 +0.030	95	+0.035 +0.013				GRP 759560	GRP 759570	GRP 759580	GRP 7595100			
80	+0.060 +0.030	96	+0.035 +0.013			GRP 809640	GRP 809650	GRP 809660	GRP 809670	GRP 809680	GRP 8096100	GRP 8096120	
80	+0.060 +0.030	100	+0.035 +0.013			GRP 8010040	GRP 8010050	GRP 8010060	GRP 8010070	GRP 8010080	GRP 80100100	GRP 80100120	GRP 80100140
90	+0.071 +0.036	110	+0.035 +0.013	GRP 9011030			GRP 9011050	GRP 9011060	GRP 9011070	GRP 9011080	GRP 90110100	GRP 90110120	
100	+0.071 +0.036	120	+0.035 +0.013				GRP 10012060	GRP 10012070	GRP 10012080	GRP 100120100	GRP 100120120		GRP 100120140
110	+0.071 +0.036	130	+0.040 +0.015						GRP 11013080	GRP 110130100	GRP 110130120		
120	+0.071 +0.036	140	+0.040 +0.015						GRP 12014080	GRP 120140100	GRP 120140120		GRP 120140140
125	+0.083 +0.043	145	+0.040 +0.015							GRP 125145100	GRP 125145120		
130	+0.083 +0.043	150	+0.040 +0.015							GRP 130150100		GRP 130150130	
140	+0.083 +0.043	160	+0.040 +0.015							GRP 140160100			GRP 140160140
150	+0.083 +0.043	170	+0.040 +0.015							GRP 150170100			GRP 150170150
160	+0.083 +0.043	180	+0.040 +0.015							GRP 160180100			GRP 160180150

Non-standard sizes can be supplied. If the size you require is not listed please contact our sales dept. We also offer a specialised machining service for low volume non-standard sizes and tolerances.

Bowman International Limited reserve the right to change specifications without prior notice E & OE



Metric Flanged cast bronze - with solid graphite lubrication

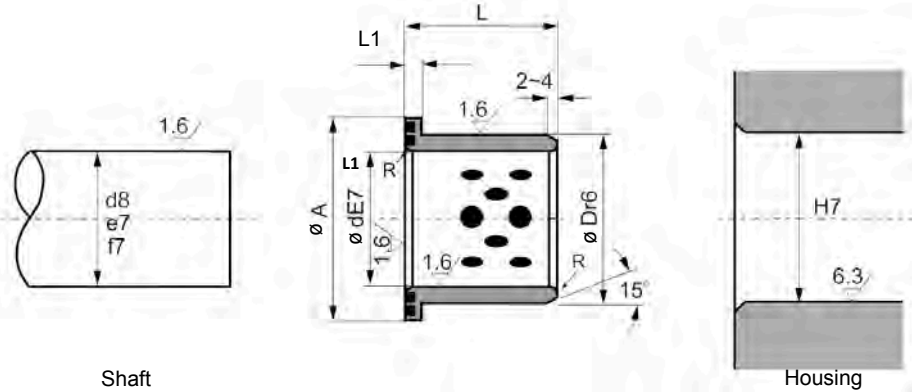

Inside Diameter E7	Outside Diameter r6	ø A	L1 -0.10	15	20	25	30	35	40	50	60	80	100
				Standard Lengths -0.10/-0.30mm									
10	+0.040 +0.025	14	+0.034 +0.023	22	2	GRF 101415	GRF 101420						
12	+0.050 +0.032	18	+0.034 +0.023	25	3	GRF 121815	GRF 121820						
13	+0.050 +0.032	19	+0.041 +0.028	26	3	GRF 131915	GRF 131920						
14	+0.050 +0.032	20	+0.041 +0.028	27	3	GRF 142015	GRF 142020						
15	+0.050 +0.032	21	+0.041 +0.028	28	3	GRF 152115	GRF 152120	GRF 152125	GRF 152130				
16	+0.050 +0.032	22	+0.041 +0.028	29	3	GRF 162215	GRF 162220	GRF 162225	GRF 162230				
20	+0.061 +0.040	30	+0.041 +0.028	40	5	GRF 203015	GRF 203020	GRF 203025	GRF 203030		GRF 203040		
25	+0.061 +0.040	35	+0.050 +0.034	45	5	GRF 253515	GRF 253520	GRF 253525	GRF 253530		GRF 253540		
30	+0.061 +0.040	40	+0.050 +0.034	50	5		GRF 304020	GRF 304025	GRF 304030	GRF 304035	GRF 304040	GRF 304050	
31.5	+0.075 +0.050	40	+0.050 +0.034	50	5		GRF 3154020			GRF 3154035			
35	+0.075 +0.050	45	+0.050 +0.034	60	5		GRF 354520		GRF 354530	GRF 354540	GRF 354550		
40	+0.075 +0.050	50	+0.050 +0.034	65	5		GRF 405020		GRF 405030	GRF 405040	GRF 405050		
45	+0.075 +0.050	55	+0.060 +0.041	70	5			GRF 455530		GRF 455040	GRF 455050	GRF 455060	
50	+0.075 +0.050	60	+0.060 +0.041	75	5			GRF 506030		GRF 506040	GRF 506050	GRF 506060	
55	+0.090 +0.060	65	+0.060 +0.041	80	5					GRF 556540		GRF 556560	
60	+0.090 +0.060	75	+0.062 +0.043	85	7.5					GRF 607540	GRF 607550		GRF 607580
63	+0.090 +0.060	75	+0.062 +0.043	90	7.5								GRF 637580
70	+0.090 +0.060	85	+0.073 +0.051	105	7.5					GRF 708550			GRF 708580
80	+0.090 +0.060	100	+0.073 +0.051	120	10						GRF 8010060	GRF 8010080	GRF 80100100
90	+0.107 +0.072	110	+0.076 +0.054	130	10						GRF 9011060	GRF 9011080	
100	+0.107 +0.072	120	+0.076 +0.054	150	10							GRF 10012080	GRF 100120100
120	+0.107 +0.072	140	+0.088 +0.063	170	10							GRF 120814080	GRF 120140100

Non-standard sizes can be supplied. If the size you require is not listed please contact our sales dept. We also offer a specialised machining service for low volume non-standard sizes and tolerances.
Bowman International Limited reserve the right to change specifications without prior notice E & OE



Metric Flanged cast bronze with solid graphite lubrication

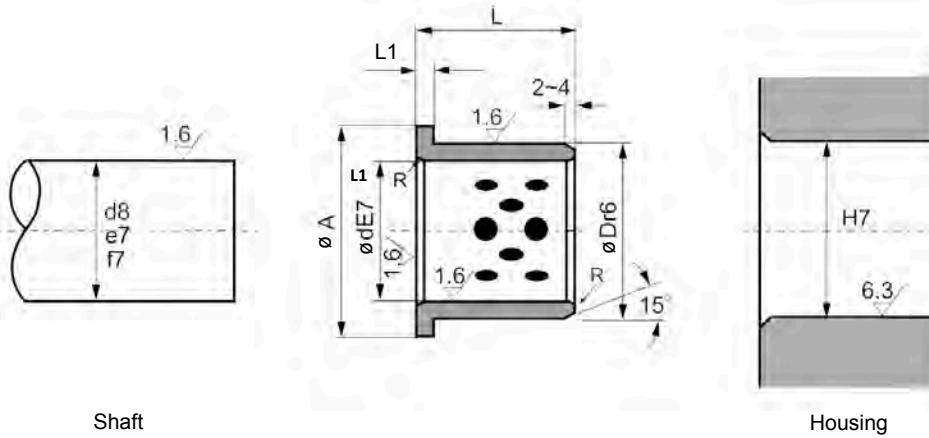

Shaft

Housing

Inside Diameter E7	Outside Diameter r6	ø A	L1	15	20	25	30	35	45	55	65		
				Standard Lengths -0.10/-0.30mm									
12	+0.050 +0.032	18	+0.034 +0.023	25	4	GRFP 121815							
16	+0.050 +0.032	22	+0.041 +0.028	30	5		GRFP 162220						
20	+0.061 +0.040	28	+0.041 +0.028	36	5			GRFP 202825					
25	+0.061 +0.040	33	+0.050 +0.034	43	5				GRFP 253330				
30	+0.061 +0.040	38	+0.050 +0.034	48	5					GRFP 303835			
40	+0.075 +0.050	50	+0.050 +0.034	60	5						GRFP 405045		
50	+0.075 +0.050	62	+0.060 +0.041	75	6							GRFP 506255	
60	+0.090 +0.060	75	+0.062 +0.043	90	7								GRFP 607565

Non-standard sizes can be supplied. If the size you require is not listed please contact our sales dept. We also offer a specialised machining service for low volume non-standard sizes and tolerances.

Bowman International Limited reserve the right to change specifications without prior notice E & OE



Cast bronze thrust washers with solid graphite lubrication

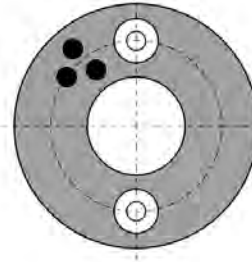
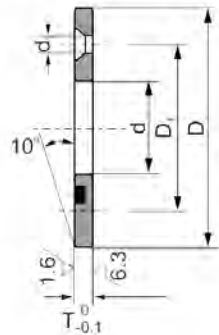

Part Number	d	D	T	Bolt			
				D ₁	Q'ty	Size	d ₁
GRW 103003	10.2	30	3	-	-	-	-
GRW 124003	12.2	40	3	28	2	M3	3.5
GRW 134003	13.2	40	3	28	2	M3	3.5
GRW 144003	14.2	40	3	28	2	M3	3.5
GRW 155003	15.2	50	3	35	2	M3	3.5
GRW 165003	16.2	50	3	35	2	M3	3.5
GRW 165003N	16.2	50	3	-	-	-	-
GRW 185003	18.2	50	3	35	2	M3	3.5
GRW 205005	20.2	50	5	35	2	M5	6
GRW 205005N	20.2	50	5	-	-	-	-
GRW 255505	25.2	55	5	40	2	M5	6
GRW 255505N	25.2	55	5	-	-	-	-
GRW 306005	30.2	60	5	45	2	M5	6
GRW 357005	35.2	70	5	50	2	M5	6
GRW 408007	40.2	80	7	60	2	M6	7
GRW 459007	45.3	90	7	67.5	2	M6	7
GRW 5010008	50.3	100	8	75	4	M6	7
GRW 5511008	55.3	110	8	85	4	M6	7
GRW 6012008	60.3	120	8	90	4	M8	9
GRW 6512508	65.3	125	8	95	4	M8	9
GRW 7013010	70.3	130	10	100	4	M8	9
GRW 7514010	75.3	140	10	110	4	M8	9
GRW 8015010	80.3	150	10	120	4	M8	9
GRW 9017010	90.5	170	10	140	4	M10	11
GRW 10019010	100.5	190	10	160	4	M10	11
GRW 12020010	120.5	200	10	175	4	M10	11

Non-standard sizes can be supplied. If the size you require is not listed please contact our sales dept. We also offer a specialised machining service for low volume non-standard sizes and tolerances.

Bowman International Limited reserve the right to change specifications without prior notice E & OE



Cast bronze wear strips with solid graphite lubrication

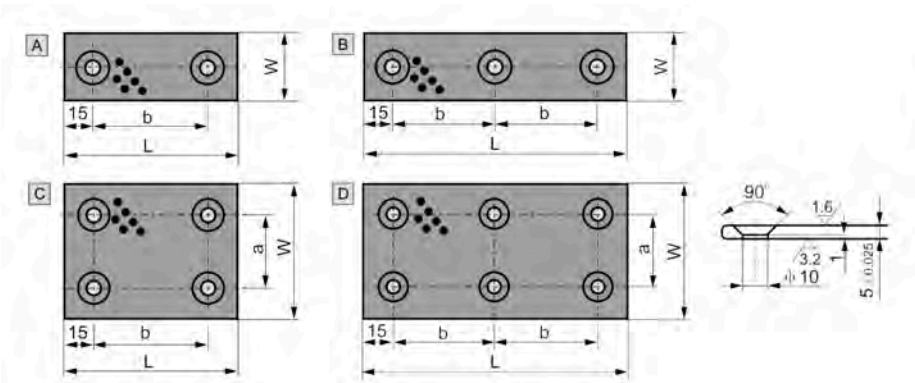

Part Number	W	L	a	b	Type
GRS 1850	18	50	-	20	A
GRS 1875	18	75	-	45	A
GRS 18100	18	100	-	70	A
GRS 18150	18	150	-	60	B
GRS 2850	28	50	-	20	A
GRS 2875	28	75	-	45	A
GRS 28100	28	100	-	70	A
GRS 28150	28	150	-	60	B
GRS 3850	38	50	-	20	A
GRS 3875	38	75	-	45	A
GRS 38100	38	100	-	70	A
GRS 38150	38	150	-	60	B
GRS 4875	48	75	-	45	A
GRS 48100	48	100	-	70	A
GRS 48125	48	125	-	95	A
GRS 48150	48	150	-	60	B
GRS 7575	75	75	45	45	C
GRS 75100	75	100	45	70	C
GRS 75125	75	125	45	95	C
GRS 75150	75	150	45	60	D
GRS 100100	100	100	70	70	C
GRS 100125	100	125	70	95	C
GRS 100150	100	150	70	60	D

Non-standard sizes can be supplied. If the size you require is not listed please contact our sales dept. We also offer a specialised machining service for low volume non-standard sizes and tolerances.

Bowman International Limited reserve the right to change specifications without prior notice E & OE

Mechanical properties WMG series (Thermoplastic composite bushes)



Min / Max operating temperature	-40°C to +130 °C
Tensile strength	210 MPa
Compressive strength	205 MPa (80N/mm ²)
Maximum load	80 MPa
Shore D hardness	80
Coefficient of friction	0.08 – 0.15
Material nominal density	1.45 g/cm ³
Modulus of elasticity	7800 MPa
Recommended shaft finish	Ra ≤ 0.4 μm (N5)
Recommended Shaft Hardness	HRC60
Maximum sliding velocity - constant	1 m/s
Maximum sliding velocity - short period (Rotational)	2 m/s
Maximum sliding velocity (Linear)	4 m/s

Material

Thermoplastic with Fibres and solid lubricants
PA66 + GF + PTFE

Recommended Fitting Data for WMG plain and flanged bushes

(Dimensions and tolerances to Din 1494)

Housing	H7
Shaft Size	h9
Bore of bush once fitted	E10
Flange outside diameter	d13
Flange thickness	+0/-0.14

Recommended Fitting Data for WMG washers

Shaft Size	h9
------------	----

Fitting Guidelines

Always use a fitting pin

Chamfer lead in on housing to assist with assembly

RoHS compliant

Suitable for food industry machinery

All testing carried out at 20°C

All dimensions and clearances are based on steel housings being used. Small allowances must be made for softer housing materials such as Aluminium.

Bowman International Limited reserve the right to change specifications without prior notice. E & OE.



WMG Metric Plain Plastic Bearings

Reference	Bore	Outside Diameter	Length (L)
WMG 0103 -L	1	3	02
WMG 0203 -L	2	3	03
WMG 02504 -L	2.5	4	05
WMG 0304 -L	3	4	03 05 06
WMG 0405 -L	4	5	04 06
WMG 04506 -L	4.5	6	08
WMG 0407 -L	4	7	05
WMG 0506 -L	5	6	05 07
WMG 0507 -L	5	7	05 08 10
WMG 0607 -L	6	7	06 17.5
WMG 0608 -L	6	8	04 05 05.5 06 08 09 10 11 12 13 15 25
WMG 0708 -L	7	8	10 19
WMG 0709 -L	7	9	08 09 10 12
WMG 0809 -L	8	9	05 06 08 12
WMG 0810 -L	8	10	05 06 07 08 10 12 13 15 16 20 22
WMG 0911 -L	9	11	06
WMG 1011 -L	10	11	06 10 25
WMG 1012 -L	10	12	04 04.5 05 06 07 08 09 10 12 14 15 17 20
WMG 1213 -L	12	13	12 15
WMG 1214 -L	12	14	04 05 06 08 10 12 14 15 20 25
WMG 1215 -L	12	15	06 22
WMG 1216 -L	12	16	10 20
WMG 1315 -L	13	15	070 075
WMG 1315 -L	13	15	10 15 20 25
WMG 1416 -L	14	16	03 06 08 10 12 15 20 25
WMG 1516 -L	15	16	15
WMG 1517 -L	15	17	04 10 12 15 20 25
WMG 1618 -L	16	18	05.5 08 10 12 13.5 15 20 25 30 50
WMG 1820 -L	18	20	10 12 15 20 25 45
WMG 1922 -L	19	22	06 28 35
WMG 2021 -L	20	21	20
WMG 2022 -L	20	22	15 20 22 30
WMG 2023 -L	20	23	10 15 20 23 24 25 30
WMG 2224 -L	22	24	10 15 17 20 30
WMG 2225 -L	22	25	15 20 25 30
WMG 2427 -L	24	27	06 15 20 25 30
WMG 2526 -L	25	26	25
WMG 2528 -L	25	28	15 20 24 25 30 35 50
WMG 2630 -L	26	30	16
WMG 2730 -L	27	30	05
WMG 2832 -L	28	32	10.5 12 15 20 23 25 30
WMG 3031 -L	30	31	12 30
WMG 3034 -L	30	34	15 20 24 25 30 35 40 52.5
WMG 3236 -L	32	36	30 40
WMG 3539 -L	35	39	14 20 25 30 40 50
WMG 3640 -L	36	40	20
WMG 3741 -L	37	41	20
WMG 4044 -L	40	44	10 16 20 30 40 50

Larger plain sizes available data upon request

Non-standard sizes can be supplied. If the size you require is not listed please contact our sales dept. We also offer a specialised machining service for low volume non-standard sizes and tolerances.

Bowman International Limited reserve the right to change specifications without prior notice E & OE



WMFG Flanged Plastic Bearings

Reference	Bore	Outside Diameter	Length (L)	Flange Outside diameter	Flange Thickness
WMFG 0304 -L	3	4	02 0275 03 05	7	0.75
WMFG 0405 -L	4	5	03 04 06	9.5	0.75
WMFG 04050 -L	4	5	04 06	9.5	0.75
WMFG 040508 -L	4	5	10	8	1
WMFG 0506 -L	5	6	035 04 05 06 15	10	0.5
WMFG 0507 -L	5	7	03 04 05 30	11	1
WMFG 050709 -L	5	7	05	9.5	1
WMFG 050715 -L	5	7	04	15	1
WMFG 0607 -L	6	7	024	11	0.5
WMFG 0607 -L	6	7	045 06 10	11	0.5
WMFG 0607 -L	6	7	06 10	11	0.5
WMFG 0608 -L	6	8	025 04 048 05 06 07 08 10 25 35	12	1
WMFG 060814 -L	6	8	12 028	14	1
WMFG 0708 -L	7	8	03 08	12	0.5
WMFG 0709 -L	7	9	06 10 12	15	1
WMFG 070919 -L	7	9	10	19	1
WMFG 0809 -L	8	9	03 055 08 12	15	0.5
WMFG 0810 -L	8	10	03 04 0 065 07 09 10 15 25 30	15	1
WMFG 081012 -L	8	10	125	12	1
WMFG 081013 -L	8	10	8	13	1
WMFG 081014 -L	8	10	06 08 10	14	1
WMFG 081016 -L	8	10	11 155	16	1.5
WMFG 081017 -L	8	10	15	17	1
WMFG 0910 -L	9	10	065 17	15	0.5
WMFG 1011 -L	10	11	026 044 10	15	0.5
WMFG 1012 -L	10	12	035 04 05 06 07 09 10 12 15 17	18	1
WMFG 101214 -L	10	12	07	14	1
WMFG 101216 -L	10	12	06 09 12 15	16	1
WMFG 1213 -L	12	13	03 12	17	0.5
WMFG 1214 -L	12	14	03 06 07 09 10 11 12 15 17 20 24	20	1
WMFG 121418 -L	12	14	04 08 10 12 15 20	18	1
WMFG 1315 -L	13	15	06	22	1
WMFG 1416 -L	14	16	03 04 06 08 10 12 17 21	22	1
WMFG 1516 -L	15	16	02 025 03 15	20	0.5
WMFG 1517 -L	15	17	04 045 05 09 12 17 20	23	1
WMFG 151824 -L	15	18	32	24	1.5
WMFG 1618 -L	16	18	04 06 09 12 17 21	24	1
WMFG 1719 -L	17	19	09 25	25	1
WMFG 1820 -L	18	20	04 06 09 11 12 17 22 30 32	26	1
WMFG 182022 -L	18	20	6	22	1
WMFG 1822 -L	18	22	28	26	2
WMFG 2021 -L	20	21	20	25	0.5
WMFG 2023 -L	20	23	07 11 16 21	30	1.5
WMFG 202326 -L	20	23	21.5	26	1.5
WMFG 202328 -L	20	23	15	28	1.5
WMFG 222535 -L	22	25	315	35	1.5
WMFG 2427 -L	24	27	07 10	32	1.5
WMFG 2526 -L	25	26	25	30	0.5
WMFG 2527 -L	25	27	48	32	1
WMFG 2528 -L	25	28	11 16 21	35	1.5
WMFG 2830 -L	28	30	10	35	1
WMFG 2830 -L	28	30	36	36	1
WMFG 283239 -L	28	32	20	39	2
WMFG 3032 -L	30	32	04 12 17 22	37	1
WMFG 3034 -L	30	34	09 16 20 26 37	42	2
WMFG 3236 -L	32	36	16 26	40	2
WMFG 3438 -L	34	38	35	50	2
WMFG 3539 -L	35	39	058 07 16 26 36	47	2
WMFG 3842 -L	38	42	22	54	2
WMFG 4044 -L	40	44	07 14 20 30 40 50	52	2

Non-standard sizes can be supplied. If the size you require is not listed please contact our sales dept. We also offer a specialised machining service for low volume non-standard sizes and tolerances.

Bowman International Limited reserve the right to change specifications without prior notice E & OE



WMWG Thrust Washers (Metric)

Reference	Bore	Outside Diameter	Washer Thickness (T)	Location hole diameter (mm)
WMWG 0509 -T	5	9	0.6	no location hole
WMWG 0615 -T	6	15	1.5	no location hole
WMWG 0620 -T	6	20	1.5	1.5
WMWG 0713 -T	7	13	0.5	no location hole
WMWG 0815 -T	8	15	0.5 (1.5 *)	1.5
WMWG 0818 -T	8	18	0.5 (1.5 *)	1.5
WMWG 0918 -T	9	18	1.5	1.5
WMWG 1018 -T	10	18	1.0 2.0	no location hole
WMWG 1224 -T	12	24	1.5	1.5
WMWG 1420 -T	14	20	1.5	no location hole
WMWG 1426 -T	14	26	1.5	2
WMWG 1522 -T	15	22	0.8	no location hole
WMWG 1524 -T	15	24	(1.5 *) 2.75	1.5
WMWG 1630 -T	16	30	1.5	2
WMWG 1832-T	18	32	1.5	2
WMWG 2036-T	20	36	1.5	3
WMWG 2238-T	22	38	1.5	3
WMWG 2442-T	24	42	1.5	3
WMWG 2644-T	26	44	1.5	3
WMWG 2835-T	28	35	0.5	no location hole
WMWG 2848-T	28	48	1.5	4
WMWG 3254-T	32	54	1.5	4
WMWG 3862-T	38	62	1.5	4
WMWG 4266-T	42	66	1.5	4
WMWG 4874-T	48	74	2.0	4
WMWG 5278-T	52	78	2.0	4
WMWG 6290-T	62	90	2.0	4
WMWG 6881-T	68	81	2.0	no location hole

* denotes location hole is only standard in this washer thickness

Minimum order quantities and production lead times may apply to certain sizes

Non-standard sizes can be supplied. If the size you require is not listed please contact our sales dept. We also offer a specialised machining service for low volume non-standard sizes and tolerances.

Bowman International Limited reserve the right to change specifications without prior notice E & OE

TWP Range of Acetal Copolymer Thrust Washers



- Good sliding properties
- Good temperature range
- Lightweight
- No maintenance
- Very good dimensional stability
- High impact strength
- Physiologically inert
- Good chemical resistance ($4 < \text{pH} < 13$)
- Excellent resilience
- Ideal for food industry

Other Plastic Materials Available to Special Order

Material Properties

Acetal Copolymer (POM C)

Acetal Copolymer has a good combination of properties, including low moisture absorption, good dimensional stability, and low friction, making it suitable for Bearing applications.

Technical Specification

Property	ASTM Methods	Units	ACETAL Copolymer
Colour	-	-	White
Specific Gravity	D792	-	1.41
Water Absorption			
Saturation in water	-	%	0.85
Tensile Strength	D638	N/mm ²	70
Tensile Modulus	D638	N/mm ²	3000
Elongation	D638	%	30
Flexural Strength	D790	N/mm ²	-
Flexural Modulus	D790	N/mm ²	-
Impact - Izod Notched	D256	J/m	80
Hardness	Rockwell Shore D	- -	M86 -
Melt Point	D2117	°C	165
Max allowable service temp in air			
for short periods	-	°C	140
continuously for 20,000hrs	-	°C	100
Linear thermal expansion coefficient	D696	K ⁻¹ x10 ⁻⁵	12.5
Thermal Conductivity	C117	W/K.m	0.31
Flammability	UL	-	HB
Volume Resistivity	D257	Ohm.cm	10 ¹⁴
Dielectric Strength	D149	kV/mm	20
Coefficient of friction (dryVs steel) dynamic		μ	0.25-0.30
Limiting PV (V= 0.1 m/s) unlubricated		N/mm ²	m/s 0.16
(V= 1.0 m/s) unlubricated		N/mm ²	m/s 0.10
continuously lubricated		N/mm ²	m/s 0.50
Maximum long term static load		N/mm ²	22
Maximum velocity (sliding dry)		m/s	2
Outside applications - UV resistance	-	-	C/B
Acids - Strong (pH <3)	-	-	C
Alkalis - Strong (pH >11)	-	-	A
Chlorinated Hydrocarbons	-	-	A/B
Hot Water	-	-	A

'A' - No attack; 'B' - Mild attack by absorption; 'C' - Dimensional change due to absorption, 'D' - Decomposition in short time.

This data gives typical values and are not intended to represent specification. Their aim is to guide the user towards a material choice.

The warranties given by Bowman International Ltd ("Bowman") are as set out in their Conditions of Business, subject to which the products referred to in this brochure are offered. Copies of our conditions are available on request.

The suitability of the proposed use of any of the products for any particular purpose is the responsibility of the customer.

Metric Stock Sizes

DIM 'A'	DIM 'B'	DIM 'C'	PART No.
10.7	24	1.5	TWP 24
12.7	26	1.5	TWP 26
16.7	30	1.5	TWP 30
16.7	32	1.5	TWP 32
18.7	36	1.5	TWP 36
20.7	38	1.5	TWP 38
24.7	42	1.5	TWP 42
24.7	44	1.5	TWP 44
25.7	48	1.5	TWP 48
28.7	48	1.5	TWP 48-A
30.7	54	1.5	TWP 54
36.2	62	1.5	TWP 62
41.2	66	1.5	TWP 66
46.2	74	2	TWP 74
51.2	78	2	TWP 78

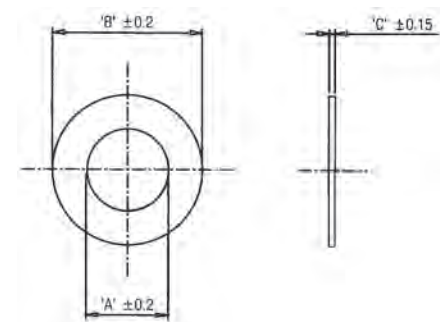

Metric Stock Sizes

DIM 'A'	DIM 'B'	DIM 'C'	PART No.
12	20	1.5	TWP 20-1
12	24	1.5	TWP 24-1
14	26	1.5	TWP 26-1
16	30	1.5	TWP 30-1
18	32	1.5	TWP 32-1
20	36	1.5	TWP 36-1
22	38	1.5	TWP 38-1
24	42	1.5	TWP 42-1
26	44	1.5	TWP 44-1
28	48	1.5	TWP 48-1
32	54	1.5	TWP 54-1
38	62	1.5	TWP 62-1
42	66	1.5	TWP 66-1
48	74	2	TWP 74-1
52	78	2	TWP 78-1

Inch and special sizes can be produced promptly to order.

Bowman International Limited reserve the right to change specifications without prior notice E & OE

Ball Bearings



Ranges

Metric, Imperial and specials.

Types

Plain and Flanged

Protection

Two Shields and Two Seals.

Material

SAE 52100 High Carbon Chrome Steel

Precision Level

Commercial, ABEC 1, ABEC 3 are available from stock

Radial Internal Clearance

d (mm)		CN		C3	
Over	Up to	Min.	Max.	Min.	Max.
2.5	6	2	13	8	23
6	10	2	13	8	23
10	18	3	18	11	25
18	24	5	20	13	28
24	30	5	20	13	28
30	40	6	20	15	33
40	50	6	23	18	36
50	65	8	28	23	43
65	80	10	30	25	51
80	100	12	36	30	58
100	120	15	41	36	66

For non catalogue items we are able to offer a wide range of material, precision and configuration options to order.



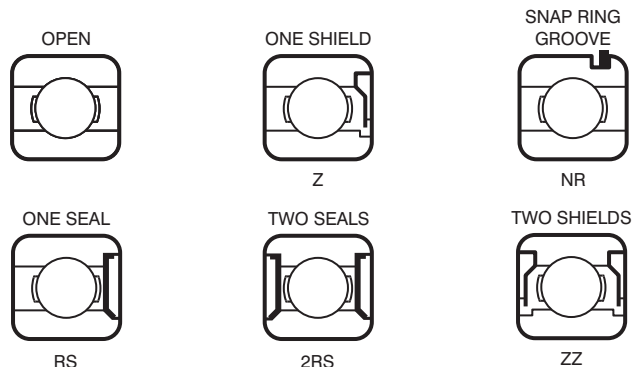
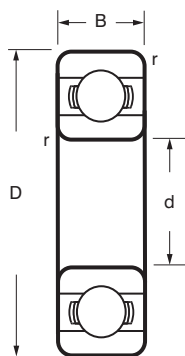

Ball Bearings 6000 Series

Bearing Number	Nominal Dimensions			Basic load ratings		Limiting speeds	
	d	D (mm)	B	Dynamic (N)	Static	Grease (RPM)	Oil
WM 6000*	10	26	8	4620	1960	30000	36000
WM 6001*	12	28	8	5070	2360	26000	32000
WM 6002*	15	32	9	5590	2850	22000	28000
WM 6003*	17	35	10	6050	3250	19000	24000
WM 6004*	20	42	12	9360	5000	17000	20000
WM 6005*	25	47	12	11200	6550	15000	18000
WM 6006*	30	55	13	13300	8300	12000	15000
WM 6007*	35	62	14	15900	10200	10000	13000
WM 6008*	40	68	15	16800	11600	9500	12000
WM 6009*	45	75	16	20800	14600	9000	11000
WM 6010*	50	80	16	21600	16000	8500	10000
WM 6011*	55	90	18	28100	21200	7500	9000
WM 6012	60	95	18	29600	23200	6700	8000
WM 6013	65	100	18	30700	25000	6300	7500
WM 6014	70	110	20	37700	31000	6000	7000
WM 6015	75	115	20	39700	33500	5600	6700
WM 6016	80	125	22	47500	40000	5300	6300
WM 6017	85	130	22	49400	43000	5000	6000
WM 6018	90	140	24	58500	50000	4800	5600
WM 6019	95	145	24	60500	54000	4500	5300
WM 6020	100	150	24	60500	54000	4300	5000

*These bearings are also available in 440 c stainless steel.

Bowman International Limited reserve the right to change specifications without prior notice E & OE

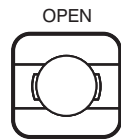
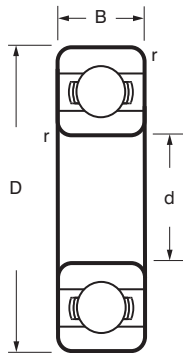

OPEN



RS



Z



2RS



NR

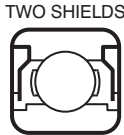

ZZ

Ball Bearings 6200 Series

Bearing Number	Nominal Dimensions			Basic load ratings		Limiting speeds	
	d	D (mm)	B	Dynamic (N)	Static	Grease (RPM)	Oil
WM 6200*	10	30	9	5070	2360	24000	30000
WM 6201*	12	32	10	6890	3100	22000	28000
WM 6202*	15	35	11	7800	3750	19000	24000
WM 6203*	17	40	12	9560	4750	17000	20000
WM 6204*	20	47	14	12700	6550	15000	18000
WM 6205*	25	52	15	14000	7800	12000	15000
WM 6206*	30	62	16	19500	11200	10000	13000
WM 6207*	35	72	17	25500	15300	9000	11000
WM 6208*	40	80	18	30700	19000	8500	10000
WM 6209*	45	85	19	33200	21600	7500	9000
WM 6210*	50	90	20	35100	23200	7000	8500
WM 6211*	55	100	21	43600	29000	6300	7500
WM 6212	60	110	22	47500	32500	6000	7000
WM 6213	65	120	23	55900	40500	5300	6300
WM 6214	70	125	24	60500	45000	5000	6000
WM 6215	75	130	25	66300	49000	4800	5600
WM 6216	80	140	26	70200	55000	4500	5300
WM 6217	85	150	28	83200	64000	4300	5000
WM 6218	90	160	30	95600	73500	3800	4500
WM 6219	95	170	32	10800	81500	3600	4300
WM 6220	100	180	34	124000	93000	3400	4000

*These bearings are also available in 440 c stainless steel.

Ball Bearings 6300 Series

Bearing Number	Nominal Dimensions			Basic load ratings		Limiting speeds	
	d	D (mm)	B	Dynamic (N)	Static	Grease (RPM)	Oil
WM 6300*	10	35	11	8060	3400	20000	26000
WM 6301*	12	37	12	9750	4150	19000	24000
WM 6302*	15	42	13	11400	5400	17000	20000
WM 6303*	17	47	14	13500	6550	16000	19000
WM 6304*	20	52	15	15900	7800	13000	16000
WM 6305*	25	62	17	22500	11600	11000	14000
WM 6306*	30	72	19	28100	16000	9000	11000
WM 6307*	35	80	21	33200	19000	8500	10000
WM 6308*	40	90	23	41000	24000	7500	9000
WM 6309*	45	100	25	52700	31500	6700	8000
WM 6310*	50	110	27	61800	38000	6300	7500
WM 6311*	55	120	29	71500	45000	5600	6700
WM 6312	60	130	31	81900	52000	5000	6000
WM 6313	65	140	33	92300	60000	4800	5600
WM 6314	70	150	35	104000	68000	4500	5300
WM 6315	75	160	37	114000	76500	4300	5000

*These bearings are also available in 440 c stainless steel.

Bowman International Limited reserve the right to change specifications without prior notice E & OE

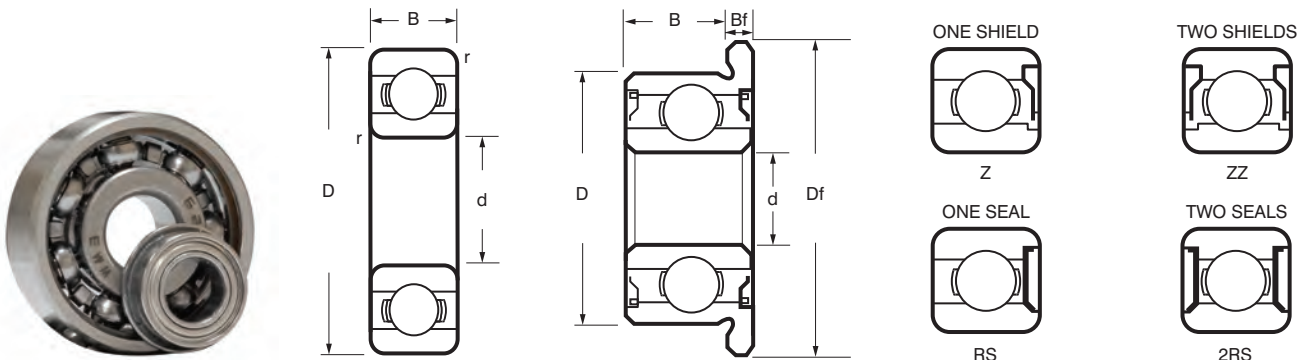

Metric Miniature Bearings

Bearing Number	Nominal Dimensions				Basic load		Flange Diameter Df (mm)	Flange Width Bf		Weight	
	d	D	B		Dynamic	Static		Open	Sealed	Open	Sealed
	(mm)				(N)		(mm)		(g)		
WM 682	2	5	1.5	2.3	169	50	6.1	0.5	0.6	0.15	0.20
WM MR52	2	5	2.0	2.5	169	50	6.2	0.6	0.6	0.14	0.20
WM 692	2	6	2.3	3.0	330	99	7.5	0.6	0.8	0.28	0.35
WM MR62	2	6	2.5	2.5	330	99	7.2	0.6	0.6	0.28	0.33
WM MR72	2	7	2.5	3.0	386	129	8.2	0.6	0.6	0.43	0.53
WM 602	2	7	2.8	3.5	386	129	8.5	0.7	0.9	0.50	0.60
WM MR63	3	6	2.0	2.5	209	74	7.2	0.6	0.6	0.20	0.28
WM 683	3	7	2.0	3.0	311	112	8.1	0.5	0.8	0.32	0.45
WM MR83	3	8	2.5	3.0	395	141	9.2	0.6	0.6	0.51	0.67
WM 693	3	8	3.0	4.0	558	180	9.5	0.7	0.9	0.60	0.80
WM MR93	3	9	2.5	4.0	571	189	10.2	0.6	0.8	0.75	1.30
WM 603	3	9	3.0	5.0	571	189	10.5	0.7	1.0	0.84	1.43
WM 623	3	10	4.0	4.0	631	219	11.5	1.0	1.0	1.45	1.65
WM 633	3	13	5.0	5.0	1301	488	15.0	1.0	1.0	3.27	3.43
WM MR74	4	7	2.0	2.5	311	115	8.2	0.6	0.6	0.23	0.33
WM MR84	4	8	2.0	3.0	395	141	9.2	0.6	0.6	0.39	0.56
WM 684	4	9	2.5	4.0	641	227	10.3	0.6	1.0	0.65	1.00
WM MR104	4	10	3.0	4.0	711	272	11.2	0.6	0.8	0.96	1.33
WM 694	4	11	4.0	4.0	957	350	12.5	1.0	1.0	1.69	1.75
WM 604	4	12	4.0	4.0	957	350	13.5	1.0	1.0	2.19	2.34
WM 624	4	13	5.0	6.0	1301	488	15.0	1.0	1.0	3.10	3.20
WM 634	4	16	5.0	6.0	1340	523	18.0	1.0	1.0	5.24	5.44
WM MR85	5	8	2.0	2.5	308	120	9.2	0.6	0.6	0.25	0.34
WM MR95	5	9	2.5	3.0	431	169	10.2	0.6	0.6	0.54	0.58
WM MR105	5	10	3.0	4.0	431	169	11.2	0.6	0.8	0.91	1.26
MR115	5	11		4.0	716	282	12.6		0.8		0.62
WM 685	5	11	3.0	5.0	716	282	12.5	0.8	1.0	1.16	1.93
WM 695	5	13	4.0	4.0	1077	432	15.0	1.0	1.0	2.39	2.31
WM 605	5	14	5.0	5.0	329	507	16.0	1.0	1.0	3.46	3.75
WM 625	5	16	5.0	5.0	1729	675	18.0	1.0	1.0	4.95	5.10
WM 635	5	19	5.0	5.0	2336	896	22.0	1.5	1.5	8.50	8.89

All bearings are also available in 440 c stainless steel.

All bearings are also available with ceramic balls.

Bowman International Limited reserve the right to change specifications without prior notice E & OE

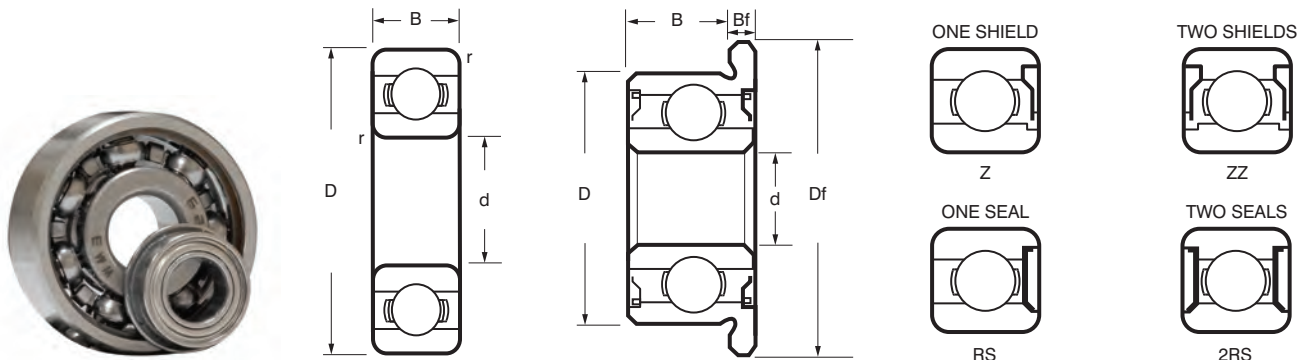

Metric Miniature Bearings

Bearing Number	Nominal Dimensions				Basic load		Flange Diameter Df (mm)	Flange Width Bf		Weight	
	d	D	B		Dynamic	Static		Open	Sealed	Open	Sealed
	(mm)				(N)		(mm)		(g)		
WM MR106	6	10	2.5	3.0	496	218	11.2	0.6	0.6	0.55	0.70
WM MR126	6	12	3.0	4.0	714	295	13.2	0.6	0.8	1.25	1.66
WM 686	6	13	3.5	5.0	1082	442	15.0	1.0	1.1	1.87	2.68
WM 696	6	15	5.0	5.0	1340	523	17.0	1.2	1.2	3.85	3.65
WM 606	6	17	6.0	6.0	2263	846	19.0	1.2	1.2	5.94	6.89
WM 626	6	19	6.0	6.0	2336	896	22.0	1.5	1.5	8.12	8.65
WM 636	6	22	7.0	7.0	3333	1423	25.0	1.5	1.5	13.90	14.50
WM MR117	7	11	2.5	3.0	455	202	12.2	0.6	0.6	0.59	0.71
WM MR137	7	13	3.0	4.0	541	276	14.2	0.6	0.8	1.52	2.01
WM 687	7	14	3.5	5.0	1173	613	16.0	1.0	1.1	2.03	2.95
WM 697	7	17	5.0	5.0	1605	719	19.0	1.2	1.2	5.26	6.01
WM 607	7	19	6.0	6.0	2336	896	22.0	1.5	1.5	7.80	8.24
WM 627	7	22	7.0	7.0	3287	1379	25.0	1.5	1.5	12.70	13.10
WM 637	7	26	9.0	9.0	4563	1983	29.0	2.0	2.0	24.20	25.80
WM MR128	8	12	2.5	3.5	543	274	13.2	0.6	0.8	0.70	0.99
WM MR148	8	14	3.5	4.0	817	386	15.6	0.8	0.8	1.90	2.19
WM 688	8	16	4.0	5.0	1252	592	18.0	1.0	1.1	3.11	4.05
WM 698	8	19	6.0	6.0	2237	917	22.0	1.5	1.5	7.12	7.57
WM 608	8	22	7.0	7.0	3293	1379	25.0	1.5	1.5	11.80	12.90
WM 628	8	24	8.0	8.0	3333	1423				17.10	18.50
WM 638	8	28	9.0	9.0	4563	1983				28.10	30.30
WM 679	9	14	3.0	4.5	919	468	15.5	0.8	0.8	1.35	1.98
WM 689	9	17	4.0	5.0	1327	668	19.0	1.0	1.1	3.41	4.38
WM 699	9	20	6.0	6.0	2467	1081	23.0	1.5	1.5	8.38	8.54
WM 609	9	24	7.0	7.0	3356	1444	27.0	1.5	1.5	14.70	16.00
WM 629	9	26	8.0	8.0	4575	1983				19.00	21.80
WM 639	9	30	10.0	10.0	4659	2080				36.20	37.10

All bearings are also available in 440 c stainless steel.

All bearings are also available with ceramic balls.

Bowman International Limited reserve the right to change specifications without prior notice E & OE

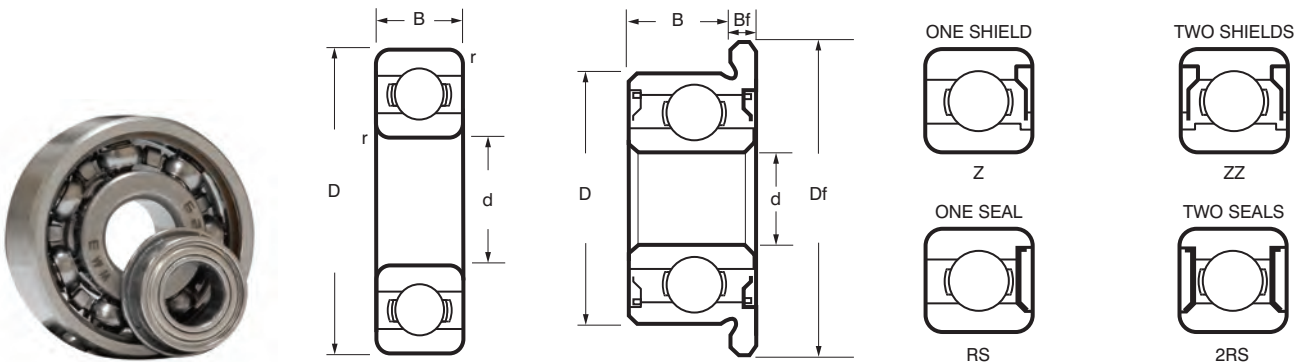

Imperial Miniature Bearings

Bearing Number	Nominal Dimensions				Basic load		Flange Diameter Df (mm)	Flange Width Bf		Weight	
	d	D	B		Dynamic	Static		Open	Sealed	Open	Sealed
	(mm)				(N)		(mm)		(g)		
WM R133	0.0937	0.1875	0.0625	0.0937	189	60	0.2340	0.0180		0.10	0.15
WM RI.5	0.0937	0.3125	0.1094	0.1406	552	176	0.3590	0.0230	0.0310	0.60	1.15
WM R144	0.1250	0.2500	0.0937	0.1094	284	96	0.2960	0.0230	0.0310	0.27	0.40
WM R2.5	0.1250	0.3125	0.1094	0.1406	558	180	0.3590	0.0230	0.0310	0.50	0.74
WM R2.6	0.1250	0.3750	0.1094	0.1406	640	227	0.4220	0.0230	0.0310	0.96	1.23
WM R2	0.1250	0.3750	0.1562	0.1562	631	219	0.4400	0.0300	0.0300	1.04	1.37
WM R2A	0.1250	0.5000	0.1719	0.1719	640	227				3.30	3.30
WM R155	0.1562	0.3125	0.1094	0.1250	359	150	0.3590	0.0230	0.0360	0.51	0.61
WM R156	0.1875	0.3125	0.1094	0.1250	359	150	0.3590	0.0230	0.0360	0.40	0.45
WM R166	0.1875	0.3750	0.1250	0.1250	709	272	0.4220	0.0230	0.0310	0.81	0.85
WM R3	0.1875	0.5000	0.1562	0.1960	1301	488	0.5650	0.0420	0.0420	2.21	2.95
WM R3A	0.1875	0.6250	0.1960	0.1960	1480	621				4.75	5.08
WM R168	0.2500	0.3750	0.1250	0.1250	373	172	0.4220	0.0230	0.0360	0.57	0.60
WM R188	0.2500	0.5000	0.1250	0.1875	1082	442	0.5470	0.0230	0.0450	1.60	2.32
WM R4	0.2500	0.6250	0.1960	0.1960	1480	621	0.6900	0.0420	0.0420	4.46	4.54
WM R4A	0.2500	0.7500	0.2188	0.2812	2336	896				7.48	10.00
WM R1810	0.3125	0.5000	0.1562	0.1562	542	276	0.5470	0.0310	0.0310	1.39	1.57
WM R6	0.3750	0.8750	0.2188	0.2812	3332	1422	0.9690	0.0620	0.0620	9.02	11.70
WM R8	0.5000	1.1250	0.2500	0.3125	5108	2413	1.2252	0.0620	0.0620	11.60	24.10

All bearings are also available in 440 c stainless steel.

All bearings are also available with ceramic balls.

Bowman International Limited reserve the right to change specifications without prior notice E & OE



BOWMAN INTERNATIONAL LIMITED

www.bowman-international.com