

Modular F.R.L. Unit



Introducing our latest F.R.L. units!

Series AC



Modular F.R.L. Unit Series AC

Space-saving design

The use of compact spacer with bracket reduces the total assembling space.

Model		Reduction (mm)
New	Old	
AC10	AC1000	4
AC20	AC2000	14
AC25	AC2500	14
AC30	AC3000	14
AC40	AC4000	18
AC40-06	AC4000-06	18
AC50	AC5000	18
AC55	AC5500	18
AC60	AC6000	18

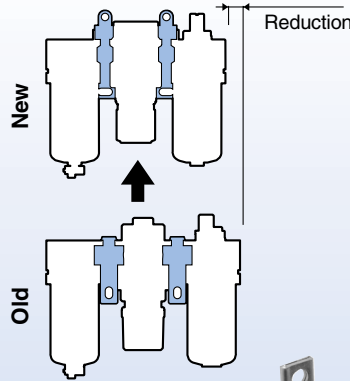

Improved visibility for lubricant drip with graduation for lubricant control

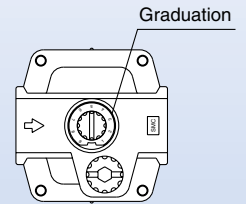

Spacer with bracket

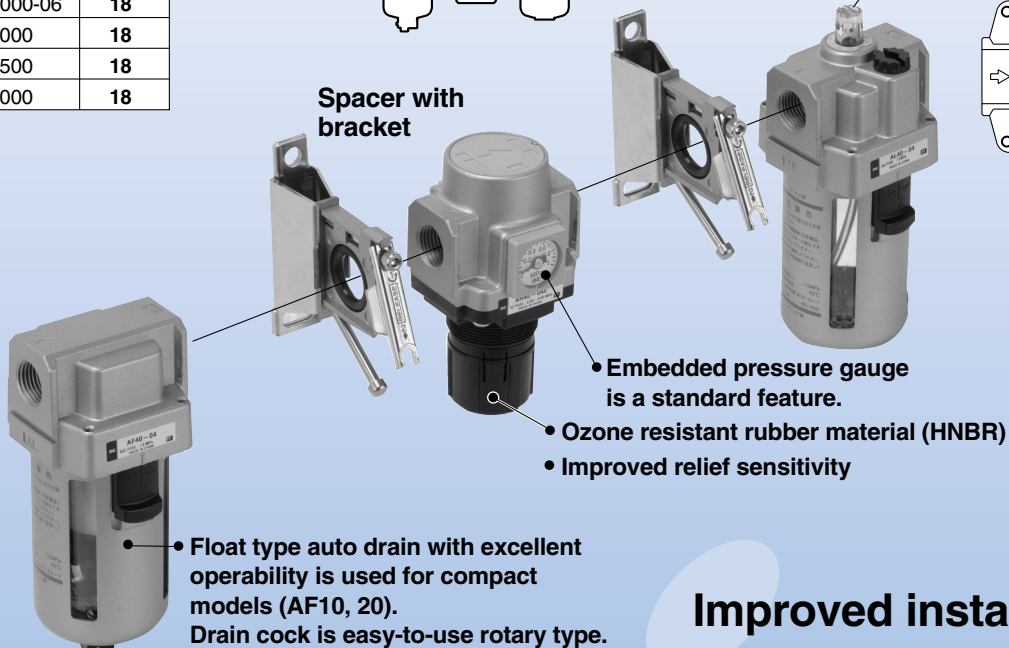

Improved installation

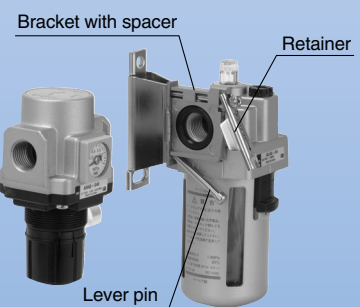

- ① Attach the component into the fitting of the spacer with bracket.
- ② Lock the lever pin into the retainer. (temporary installation)

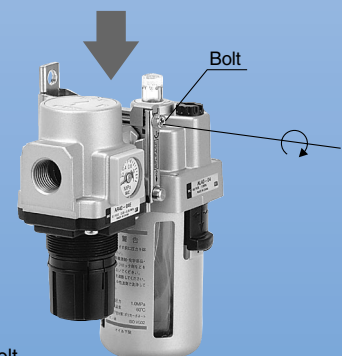

- ③ Tighten the bolt.

Knob cover

Prevents careless knob operation.

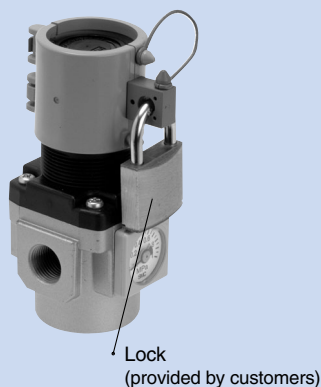
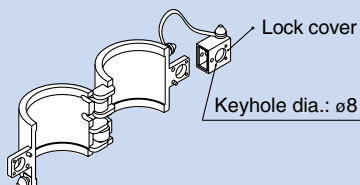

Part no.	Model
AR20P-580AS	AC20□, AR20, AR20K, AW20, AW20K, AWM20, AWD20
AR25P-580AS	AC25□, AR25, AR25K
AR30P-580AS	AC30□, AR30, AR30K, AW30, AW30K, AWM30, AWD30
AR40P-580AS	AC40□(-06), AR40(-06), AR40K(-06), AW40(-06), AW40K(-06), AWM40, AWD40

Standard Combination





Combination	Model	Port size	Component				
			Air filter AF	Regulator AR	Lubricator AL	Filter regulator AW	Mist separator AFM
AF + AR + AL 	AC10	M5 x 0.8	AF10	AR10	AL10		
	AC20	1/8, 1/4	AF20	AR20	AL20		
	AC25	1/4, 3/8	AF30	AR25	AL30		
	AC30	1/4, 3/8	AF30	AR30	AL30		
	AC40	1/4, 3/8, 1/2	AF40	AR40	AL40		
	AC40-06	3/4	AF40-06	AR40-06	AL40-06		
	AC50	3/4, 1	AF50	AR50	AL50		
	AC55	1	AF60	AR50	AL60		
	AC60	1	AF60	AR60	AL60		
AW + AL 	AC10A	M5 x 0.8			AL10	AW10	
	AC20A	1/8, 1/4			AL20	AW20	
	AC30A	1/4, 3/8			AL30	AW30	
	AC40A	1/4, 3/8, 1/2			AL40	AW40	
	AC40A-06	3/4			AL40-06	AW40-06	
AF + AR 	AC10B	M5 x 0.8	AF10	AR10			
	AC20B	1/8, 1/4	AF20	AR20			
	AC25B	1/4, 3/8	AF30	AR25			
	AC30B	1/4, 3/8	AF30	AR30			
	AC40B	1/4, 3/8, 1/2	AF40	AR40			
	AC40B-06	3/4	AF40-06	AR40-06			
	AC50B	3/4, 1	AF50	AR50			
	AC55B	1	AF60	AR50			
	AC60B	1	AF60	AR60			
AF + AFM + AR 	AC20C	1/8, 1/4	AF20	AR20			AFM20
	AC25C	1/4, 3/8	AF30	AR25			AFM30
	AC30C	1/4, 3/8	AF30	AR30			AFM30
	AC40C	1/4, 3/8, 1/2	AF40	AR40			AFM40
	AC40C-06	3/4	AF40-06	AR40-06			AFM40-06
AW + AFM 	AC20D	1/8, 1/4				AW20	AFM20
	AC30D	1/4, 3/8				AW30	AFM30
	AC40D	1/4, 3/8, 1/2				AW40	AFM40
	AC40D-06	3/4				AW40-06	AFM40-06

Table of Contents

■ F.R.L. Unit

Air Filter + Regulator + Lubricator	
AC10 to 60	Page 1
Filter Regulator + Lubricator	
AC10A to 40A	Page 5
Air Filter + Regulator	
AC10B to 60B	Page 7
Air Filter + Mist Separator + Regulator	
AC20C to 40C	Page 9
Filter Regulator + Mist separator	
AC20D to 40D	Page 11
Attachment Specifications	Page 13
Spacers and Brackets: Accessories	Page 18
Made to Order Specifications	Page 20

■ Modular Type Air Filter

Air Filter	
AF10 to 60	Page 23
Made to Order Specifications	Page 28
Mist Separator	
AFM20 to 40	Page 29
Micro-Mist Separator	
AFD20 to 40	Page 32

■ Modular Type Regulator

Regulator	
AR10 to 60	Page 36
Made to Order Specifications	Page 41
Regulator with Back Flow Mechanism	
AR20K to 60K	Page 43

■ Modular Type Lubricator

Lubricator	
AL10 to 60	Page 50

■ Modular Type Filter Regulator

Filter Regulator	
AW10 to 40	Page 56
Made to Order Specifications	Page 61
Filter Regulator with Back Flow Mechanism	
AW20K to 40K	Page 63
Mist Separator Regulator	
AWM20 to 40	Page 67
Micro-Mist Separator Regulator	
AWD20 to 40	Page 71

Simple Specials System

A system designed to respond quickly and easily to your special ordering needs.

Simple Specials Order Specifications

- ① Modular/Attachment combination & Combination order
Attachment symbols:
Piping adapter: E□0
Pressure switch: IS1000□
Check valve: AKM
Cross interface: Y□4
3-port valve for releasing residual pressure:
VHS□□
- ② Modular products, Combination of special order numbers & Combination order
Special orders for AF, AR, AL, AW, AF□, AW□

Simple
Specials
System

Short lead times

This system enables us to respond to your special needs, such as additional machining, accessory assembly, or modular unit, and deliver such special products as quickly as standard products.

Repeat orders

As soon as we receive a Simple Special part number from your previous order, we will process the order, manufacture the product, and deliver it to you.

Please contact SMC for further details on the Simple Specials System.

How to Order

AC 30 A F 03 DE KV 12R

F.R.L. unit

Body size

10	20	25	30	40	50	55	60
----	----	----	----	----	----	----	----

Model combination

Symbol	Combination				
	Air filter	Regulator	Lubricator	Filter regulator	Mist separator
Nil	①	②	③	—	—
A	—	—	②	①	—
B	①	②	—	—	—
C	①	③	—	—	②
D	—	—	—	①	②

* The number inside ○ indicates the combination order counted from the inlet side.

Thread type

Nil	Metric system thread (M5)
	Rc
N Note 1)	NPT
F Note 2)	G

Note 1) Drain guide is NPT1/4 (applicable to AC25 to 60), and the exhaust port for auto drain comes with $\phi 3/8"$ One-touch fitting (applicable to AC25 to 60).

Note 2) Drain guide is G1/4 (applicable to AC25 to 60).

Port size

Symbol	Port size	Body size							
		10	20	25	30	40	50	55	60
M5	M5	●	—	—	—	—	—	—	—
01	1/8	—	●	—	—	—	—	—	—
02	1/4	—	●	●	●	—	—	—	—
03	3/8	—	—	●	●	●	—	—	—
04	1/2	—	—	—	—	●	—	—	—
06	3/4	—	—	—	—	●	●	—	—
10	1	—	—	—	—	—	●	●	●

Accessories

Symbol	Description	Applicable model
Nil	—	—
C	Float type auto drain (N.C.) ^{Note 1)}	AC10□ to 60□
D	Float type auto drain (N.O.) ^{Note 1)}	AC25□ to 60□
E	With square embedded type pressure gauge (with limit indicator)	AC20□ to 60□
G ^{Note 2)}	With round pressure gauge (without limit indicator)	AC10□
	With round pressure gauge (with limit indicator)	AC20□ to 60□

Note 1) Applicable tube O.D for auto drain connection should be $\phi 3/8"$ in case NPT thread port is chosen.

Note 2) Mounting thread for pressure gauge:
1/16 for AC10; 1/8 for AC20 to 30; 1/4 for AC40 to 60
Pressure gauge is not mounted and is supplied loose at the time of shipment.

Optional specifications

Symbol	Description	Applicable model
1 ^{Note 1)}	0.02 to 0.2MPa setting	AC10□ to 60□
2	Metal bowl	AC10□ to 60□
3	Lubricator with drain cock	AC10□ to 60□
6	Nylon bowl	AC10□ to 60□
8	Metal bowl with level gauge	AC25□ to 60□
C	With bowl guard	AC25□ to 60□
J ^{Note 2)}	Drain guide 1/4	AC10□ to 60□
N	Non-relieving type	AC10□ to 60□
R	Flow direction: Right to left	AC10□ to 60□
W	Drain cock with barb fitting: $\phi 6 \times \phi 4$ nylon tube	AC25□ to 60□
Z ^{Note 3)}	Name plate, caution plate for bowl, and pressure gauge in imperial units (PSI, °F)	AC10□ to 60□

* When more than one specification is required, indicate in ascending alphanumeric order.

Note 1) The only difference from the standard specifications is the adjusting spring for the regulator. It does not restrict the setting of 0.2MPa or more.

Note 2) Without a valve function.

Note 3) For thread types M5 and NPT. This product is for overseas use only according to the new Measurement Law. (The SI unit type is provided for use in Japan.) Pressure switch comes with a dual unit scale in SI (MPa) and imperial (PSI) units.

Attachments

Symbol	Description	Attachment mounting position	Applicable model	Port size for intermediate air release
Nil	None	—	—	—
K	Check valve	AF + AR + [K] + AL	AC20 to 40	AC20□: 1/8 AC25□: 1/4 AC30□: 1/4 AC40□: 3/8
		AW + [K] + AL	AC20A to 40A	
S	Pressure switch	AF + AR + [S] + AL	AC20 to 60	—
		AW + [S] + AL	AC20A to 40A	
		AF + [S] + AR	AC20B to 60B	
		AF + AFM + [S] + AR	AC20C to 40C	
		AW + [S] + AFM	AC20D to 40D	
T	T-interface	AF + [T] + AR + AL	AC10 to 60	AC10□: M5 x 0.8 AC20□: 1/8 AC25□: 1/4 AC30□: 1/4 AC40□: 3/8 AC50□: 3/8 AC55□: 1/2 AC60□: 1/2
		AF + [T] + AR	AC10B to 60B	
		AF + AFM + [T] + AR	AC20C to 40C	
V	3-port valve for residual pressure release	AF + AR + AL + [V]	AC20 to 50	—
		AW + AL + [V]	AC20A to 40A	
		AF + AR + [V]	AC20B to 50B	
		AF + AFM + AR + [V]	AC20C to 40C	
		AW + AFM + [V]	AC20D to 40D	

* When more than one attachment is required, order in alphabetical order.
* Piping adapter, pressure switch with piping adapter, and cross interface need to be ordered separately.

* Contact SMC when using a pressure switch and T-interface together for AC□B.

* The bracket position varies depending on the T-interface or pressure switch mounting.

Refer to the table on page 19 for standard bracket position.

F.R.L. Unit Air Filter + Regulator + Lubricator

AC10 to 60



AC20



AC40

JIS symbol

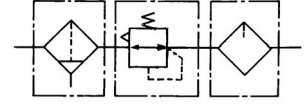

Air filter Regulator Lubricator

Standard Specifications

Model	AC10	AC20	AC25	AC30	AC40	AC40-06	AC50	AC55	AC60	
Component	Air filter	AF10	AF20	AF30	AF30	AF40	AF40-06	AF50	AF60	AF60
	Regulator	AR10	AR20	AR25	AR30	AR40	AR40-06	AR50	AR50	AR60
	Lubricator	AL10	AL20	AL30	AL30	AL40	AL40-06	AL50	AL60	AL60
Port sizes	M5 x 0.8	1/8 1/4	1/4 3/8	1/4 3/8	1/4 3/8 1/2	3/4	3/4 1	1	1	
Pressure gauge port size ^{Note 1)}	1/16	1/8	1/8	1/8	1/4	1/4	1/4	1/4	1/4	
Fluid	Air									
Proof pressure	1.5MPa									
Max. operating pressure	1.0MPa									
Set pressure range	0.05 to 0.7MPa	0.05 to 0.85MPa								
Relief pressure	Set pressure + 0.05MPa ^{Note 2)} [at relief flow rate of 0.1L/min (ANR)]									
Ambient and fluid temperature	-5 to 60°C (with no freezing)									
Nominal filtration rating	5µm									
Recommended lubricant	Class 1 turbine oil (ISO VG32)									
Bowl material	Polycarbonate									
Bowl guard	—	Option	Standard							
Regulator construction	Relieving type									
Weight (kg)	0.27	0.73	0.91	1.00	1.74	1.95	4.17	4.25	4.34	



Note 1) Pressure gauge connection threads are not required for F.R.L. unit with a square embedded type pressure gauge (AC20 to AC60).

Note 2) Not applicable to AC10.

Attachment/Accessory Part No.

Description	Model	Part no.												
		AC10	AC20	AC25	AC30	AC40	AC40-06	AC50	AC55	AC60				
Accessories	Pressure gauge ^{Note 1)}	1.0MPa	Round	G-27-10-R1	G36-10-□01	G36-10-□01	G36-10-□01	G46-10-□02	G46-10-□02	G46-10-□02	G46-10-□02	G46-10-□02		
		0.2MPa	Round	G-27-10-R1 ^{Note 3)}	G36-2-□01	G36-2-□01	G36-2-□01	G46-2-□02	G46-2-□02	G46-2-□02	G46-2-□02	G46-2-□02		
	Float type auto drain ^{Note 4)}	N.O.	—	—	AD38	AD38N ^{Note 7)}	AD38	AD38N ^{Note 7)}	AD48	AD48N ^{Note 7)}	AD48	AD48N ^{Note 7)}	AD48	AD48N ^{Note 7)}
		N.C.	AD17	AD27	AD37	AD37N ^{Note 7)}	AD37	AD37N ^{Note 7)}	AD47	AD47N ^{Note 7)}	AD47	AD47N ^{Note 7)}	AD47	AD47N ^{Note 7)}
Spacer		Y100	Y200	Y300	Y300	Y400	Y500	Y600	Y600	Y600	Y600			
Check valve ^{Note 5)}		—	AKM2000-□01 □02	AKM3000-□01 □02	AKM3000-□01 □02	AKM4000-□02 □03	—	—	—	—	—			
Pressure switch ^{Note 6)}		—	IS1000M-20	IS1000M-30	IS1000M-30	IS1000M-40	IS1000M-50	IS1000M-60	IS1000M-60	IS1000M-60	IS1000M-60			
T-interface ^{Note 5)}		Y110-M5	Y210-□01 □02	Y310-□01 □02	Y310-□01 □02	Y410-□02 □03	Y510-□02 □03	Y610-□03 □04	Y610-□03 □04	Y610-□03 □04	Y610-□03 □04			
3-port valve for residual pressure release ^{Note 6)}		—	VHS20-□01 □02	VHS30-□02 □03	VHS30-□02 □03	VHS40-□02 □03	VHS40-□06 □04	VHS50-□06 □10	—	—	—			
Piping adapter ^{Note 6)}		E100-M5	E200-□01 □02 □03	E300-□02 □03 □04	E300-□02 □03 □04	E400-□02 □03 □04 □06	E500-□06	E600-□06 □10	E600-□06 □10	E600-□06 □10				
Pressure switch with piping adapter ^{Note 6)}		—	IS1000E-20-□01 □02 □03	IS1000E-30-□02 □03 □04	IS1000E-30-□02 □03 □04	IS1000E-40-□02 □03 □04 □06	—	—	—	—				
Cross interface ^{Note 6)}		Y14-M5	Y24-□01 □02	Y34-□01 □02	Y34-□01 □02	Y44-□02 □03	Y54-□03 □04	—	—	—				



Note 1) □ in part numbers for a round pressure gauge indicates a type of connection thread. No indication is necessary for R; however, indicate N for NPT. Contact SMC regarding the connection thread NPT and pressure gauge supply for PSI unit specifications.

Note 2) Includes one O-ring and 2 mounting screws.

Note 3) For 1.0MPa.

Note 4) Minimum operating pressure: N.O. type-0.1MPa; N.C. type-0.15MPa (AD17/27).

Note 5) For F.R.L. units, port sizes not in () are for standard application.

Note 6) Separate interfaces are required for modular unit.

Note 7) When "N" is specified in the end of part number of auto drain, applicable tube O.D should be ø3/8".

Flow Characteristics (Representative values)

Condition: Inlet pressure 0.7MPa

AC10 M5 x 0.8

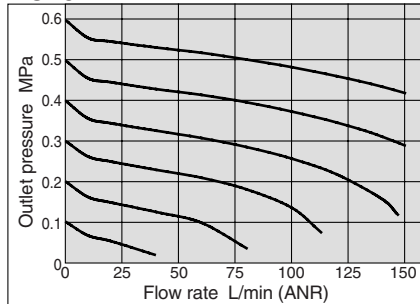

AC40-06 Rc 3/4

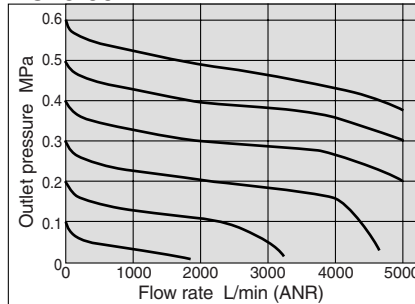

AC20 Rc 1/4

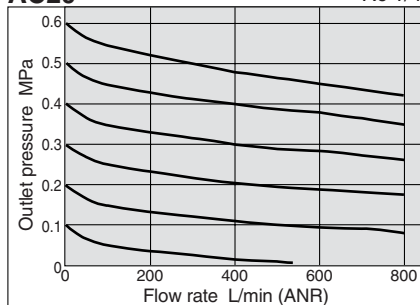

AC50 Rc 1

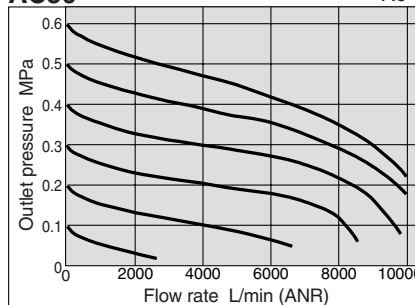

AC25 Rc 3/8

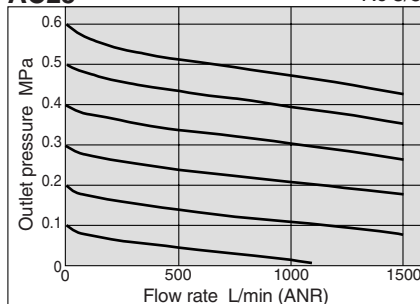

AC55 Rc 1

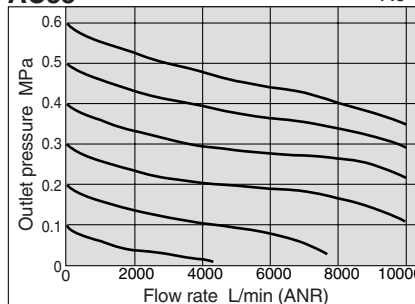

AC30 Rc 3/8

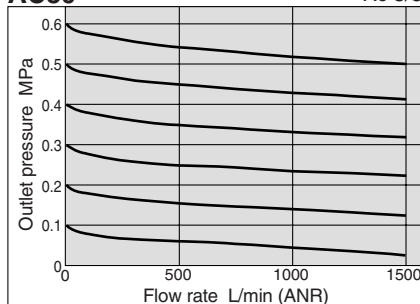

AC60 Rc 1

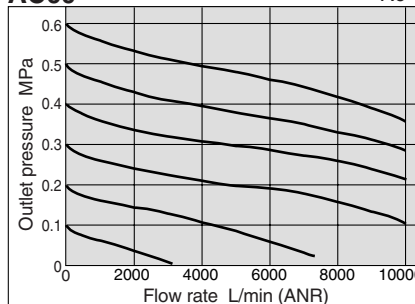

AC40 Rc 1/2

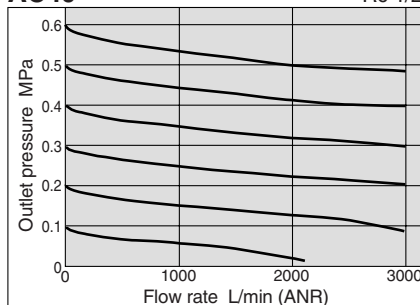

Selection

Warning

1. Float type auto drain

Operate under the following conditions to avoid malfunction.

<N.O. type>

- Operating compressor: 0.75kW [100L/min (ANR)] or more.

When using 2 or more auto drains, multiply the value above by the number of auto drains to find the capacity of the compressors you will need.

For example, when using 2 auto drains, 1.5kW [200L/min (ANR)] of the compressor capacity is required.

- Operating pressure: 0.1MPa or more.

<N.C. type>

- Operating pressure for AD17, AD27: 0.1MPa or more.

- Operating pressure for AD37, AD47: 0.15MPa or more.

2. Use a regulator or filter regulator with a back flow mechanism when mounting a 3-port valve for residual pressure release on the IN side to ensure the release of the residual pressure. Otherwise, residual pressure will not be fully released.

Caution

1. When releasing air at the intermediate position using a T-interface on the inlet side of the lubricator, lubricant may back flow. Therefore, releasing air that does not contain traces of lubricant is not possible.

To release air that does not contain traces of lubricant, use a check valve (Series AKM) on the inlet side of the lubricator to prevent a back flow of the lubricant.

2. Mounting a 3-port valve for residual pressure release on the IN side of the lubricator can cause lubricant to back flow. Take measures to prevent lubricant from splashing by installing a filter on the EXH port.
3. An F.R.L. unit shipped from the plant has its model number labeled. However, components that are combined together during the distribution process do not have a label on them.
4. Contact SMC when mounting a pressure switch, T-interface, or filter regulator on the OUT side of the 3-port valve for residual pressure release.

Specific Product Precautions

Mounting and Adjustment

Caution

1. A knob cover is available to prevent careless operation of the knob. Refer to Features 1 for details.

Piping

Warning

1. When mounting a check valve, make sure the arrow (IN side) points in the correct direction of air flow.

Air Supply

Caution

1. Use an air filter with 5 μ m or less filtration rating on the inlet side of the valve to avoid any damage to the seat caused by dust when mounting a 3-port valve for residual pressure release on the inlet side.

AC10 to 60

Conditions:
Inlet pressure 0.7MPa
Outlet pressure 0.2MPa
Flow rate 20L/min (ANR)

Pressure Characteristics (Representative values)

AC10

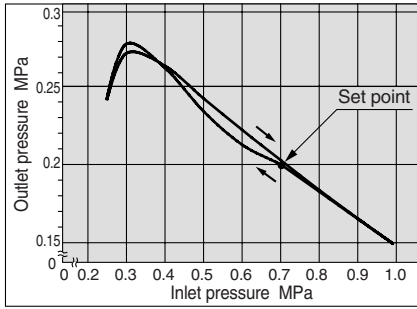

AC40-06

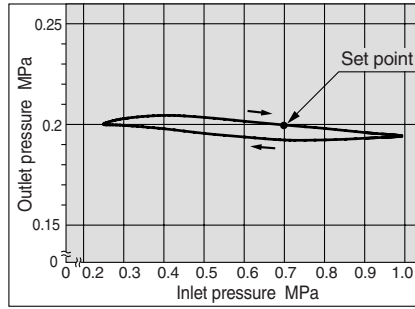

AC20

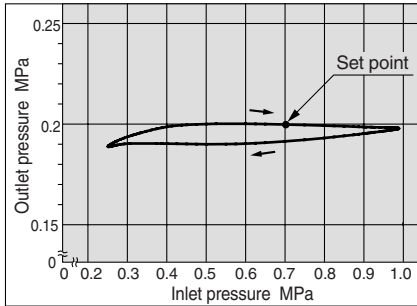

AC50

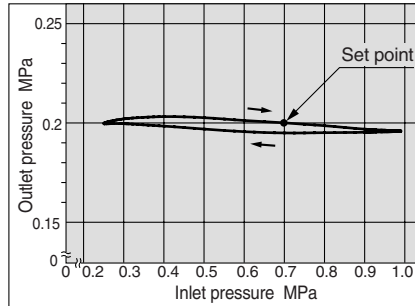

AC25

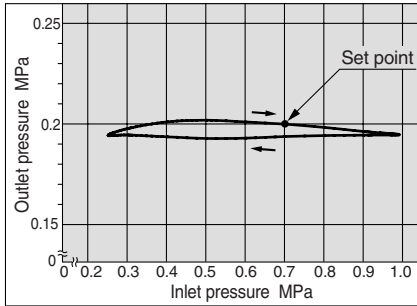

AC55

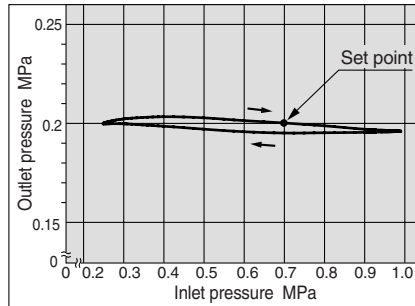

AC30

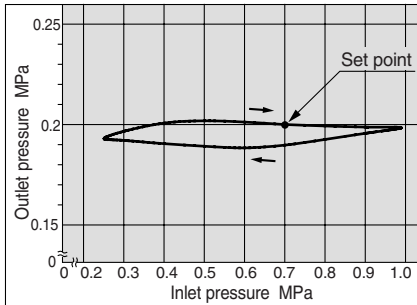

AC60

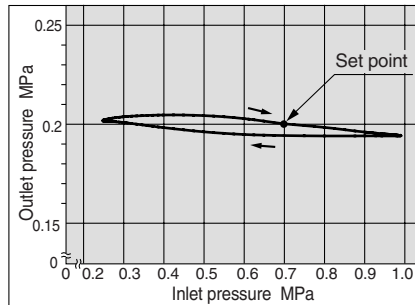

AC40

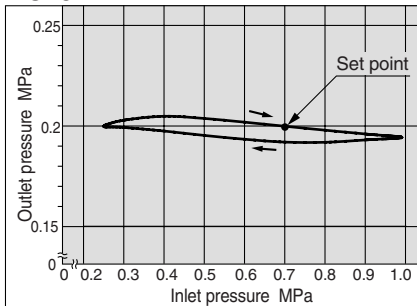

Dimensions

AC10, 20

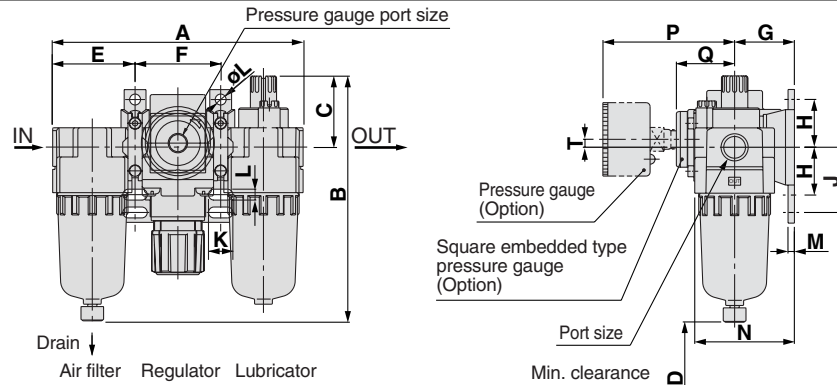

AC25, 30, 40, 50, 55, 60

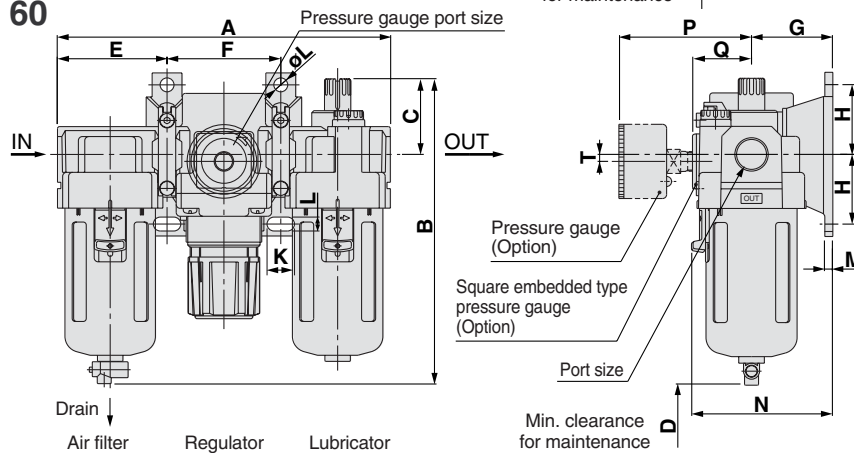

Applicable model	AC10, AC20		AC25, AC30, AC40, AC40-06, AC50, AC55, AC60				
Optional specifications	With auto drain (N.C.)	Metal bowl	With auto drain (N.O./N.C.)	Metal bowl	Metal bowl with level gauge	With drain guide	Drain cock with barb fitting
			 N.O.: Black N.C.: Gray ø10 One-touch fitting			 Width across flats 17	 Barb fitting Applicable tubing: T0604

Model	Port size	Standard specification													Accessory specification				
		A	B	C	D	Bracket mounting size								P	Q	T	B		
						E	F	G	H	J	K	L	øL					M	N
AC10	M5 x 0.8	87	85	26	35	28	31	25	20	27	7	4.5	4.5	2.8	40	26	—	0	104
AC20	1/8, 1/4	126	123	36	60	41.5	43	30	24	33	12	5.5	5.5	3.2	50	65	29.5	2 (Note 1)	141
AC25	1/4, 3/8	167	153	38	80	55	57	41	35	—	14	7	7	4	71	64	28.5	0	194
AC30	1/4, 3/8	167	153	38	80	55	57	41	35	—	14	7	7	4	71	66	30.5	3.5	194
AC40	1/4, 3/8, 1/2	220	187	40	110	72.5	75	50	40	—	18	9	9	4	88	74	35	3.5	226
AC40-06	3/4	235	187	38	110	77.5	80	50	40	—	18	9	9	4.6	88	74	35	3	226
AC50	3/4, 1	282	264	43	110	93	96	70	50	—	20	11	11	6.4	115	84	44.5	3.3	303
AC55	1	292	279	45	110	98	96	70	50	—	20	11	11	6.4	117.5	84	44.5	3.3	318
AC60	1	297	280	46	110	98	101	70	50	—	20	11	11	6.4	117.5	84	44.5	3.3	318

Model	Optional specification ^{Note 2)}			
	With barb fitting	With drain guide	Metal bowl	Metal bowl with level gauge
	B	B	B	B
AC10	—	—	85	—
AC20	—	—	123	—
AC25	161	160	166	186
AC30	161	160	166	186
AC40	195	194	200	220
AC40-06	195	194	200	220
AC50	272	271	276	296
AC55	287	286	292	312
AC60	288	287	293	313



Note 1) For AC20 only, the position of the pressure gauge is above the center of the piping.
 Note 2) For optional specifications (with barb fitting, with drain guide, with metal bowl, or with level gauge), the total length (dimension for B) will vary.

F.R.L. Unit Filter Regulator + Lubricator

AC10A to 40A



Page 20

AC20A

AC40A

Standard Specifications

Model		AC10A	AC20A	AC30A	AC40A	AC40A-06
Component	Filter regulator	AW10	AW20	AW30	AW40	AW40-06
	Lubricator	AL10	AL20	AL30	AL40	AL40-06
Port sizes		M5 x 0.8	1/8 1/4	1/4 3/8	1/4 3/8 1/2	3/4
Pressure gauge port size ^{Note 1)}		1/16	1/8	1/8	1/4	1/4
Fluid		Air				
Proof pressure		1.5MPa				
Maximum operating pressure		1.0MPa				
Set pressure range		0.05 to 0.7MPa	0.05 to 0.85MPa			
Relief pressure		Set pressure + 0.05MPa ^{Note 2)} [at relief flow rate of 0.1L/min (ANR)]				
Ambient and fluid temperature		-5 to 60°C (with no freezing)				
Nominal filtration rating		5µm				
Recommended lubricant		Class 1 turbine oil (ISO VG32)				
Bowl material		Polycarbonate				
Bowl guard		—	Option			
Filter regulator construction		Relieving type				
Weight (kg)		0.20	0.59	0.75	1.41	1.46



Note 1) Pressure gauge connection threads are not required for F.R.L. unit with a square embedded type pressure gauge (AC20A to AC40A).
 Note 2) Not applicable to AC10A.

Attachment/Accessory Part No.

Description	Model	Part no.							
		AC10A	AC20A	AC30A	AC40A	AC40A-06			
Accessories	Pressure gauge ^{Note 1)}	1.0MPa	Round	G27-10-R1	G36-10-□01	G36-10-□01	G46-10-□02	G46-10-□02	
		0.2MPa	Square embedded type ^{Note 2)}	—	GC3-10AS	GC3-10AS	GC3-10AS	GC3-10AS	
	Round		G27-10-R1 ^{Note 3)}	G36-2-□01	G36-2-□01	G46-2-□02	G46-2-□02		
		Square embedded type ^{Note 2)}	—	GC3-2AS	GC3-2AS	GC3-2AS	GC3-2AS		
Float type auto drain ^{Note 4)}	N.O.	—	—	AD38	AD38N ^{Note 7)}	AD48	AD48N ^{Note 7)}	AD48	AD48N ^{Note 7)}
	N.C.	AD17	AD27	AD37	AD37N ^{Note 7)}	AD47	AD47N ^{Note 7)}	AD47	AD47N ^{Note 7)}
Spacer		Y100	Y200	Y300		Y400		Y500	
Check valve ^{Note 5)} ^{Note 6)}		—	AKM2000- □01 □02	AKM3000- □01 □02	AKM4000- □02 □03	—			
Pressure switch ^{Note 6)}		—	IS1000M-20	IS1000M-30	IS1000M-40	IS1000M-50			
T-interface ^{Note 5)} ^{Note 6)}		Y110-M5	Y210- □01 □02	Y310- □01 □02	Y410- □02 □03	Y510- □02 □03			
3-port valve for residual pressure release ^{Note 6)}		—	VHS20- □01 □02	VHS30- □02 □03	VHS40- □02 □03 □04	VHS40-□06			
Piping adapter ^{Note 6)}		E100-M5	E200- □01 □02 □03	E300- □02 □03 □04	E400- □02 □03 □04 □06	E500-□06			
Pressure switch with piping adapter ^{Note 6)}		—	IS1000E-20 □01 □02 □03	IS1000E-30 □02 □03 □04	IS1000E-40 □02 □03 □04 □06	—			
Cross interface ^{Note 6)}		Y14-M5	Y24- □01 □02	Y34- □01 □02	Y44- □02 □03	Y54- □03 □04			



Note 1) □ in part numbers for a round pressure gauge indicates a type of connection thread. No indication is necessary for R; however, indicate N for NPT.
 Contact SMC regarding the connection thread NPT and pressure gauge supply for PSI unit specifications.
 Note 2) Includes one O-ring and 2 mounting screws.
 Note 3) For 1.0MPa.
 Note 4) Minimum operating pressure: N.O. type-0.1MPa (AD17/27); N.C. type-0.15MPa (AD37/47).
 Note 5) For F.R.L. units, port sizes not in () are for standard application.
 Note 6) Separate interfaces are required for modular unit.
 Note 7) When "N" is specified in the end of part number of auto drain, applicable tube O.D should be ø3/8".

Dimensions

AC10A, 20A

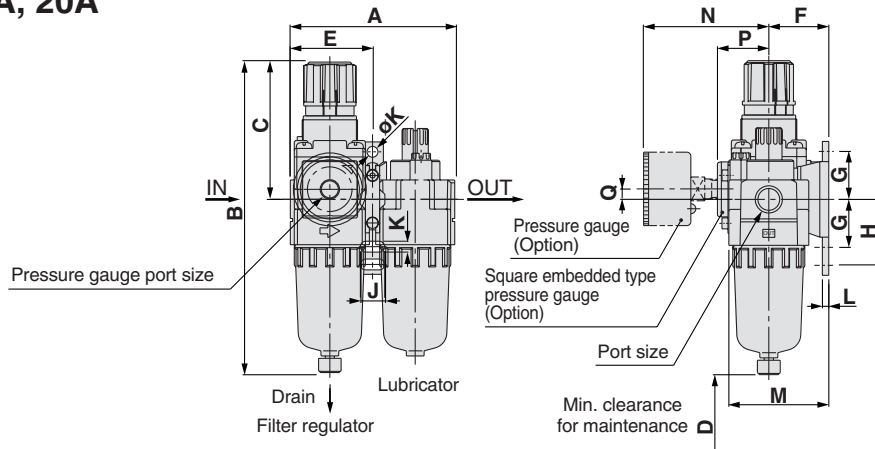

AC30A, 40A

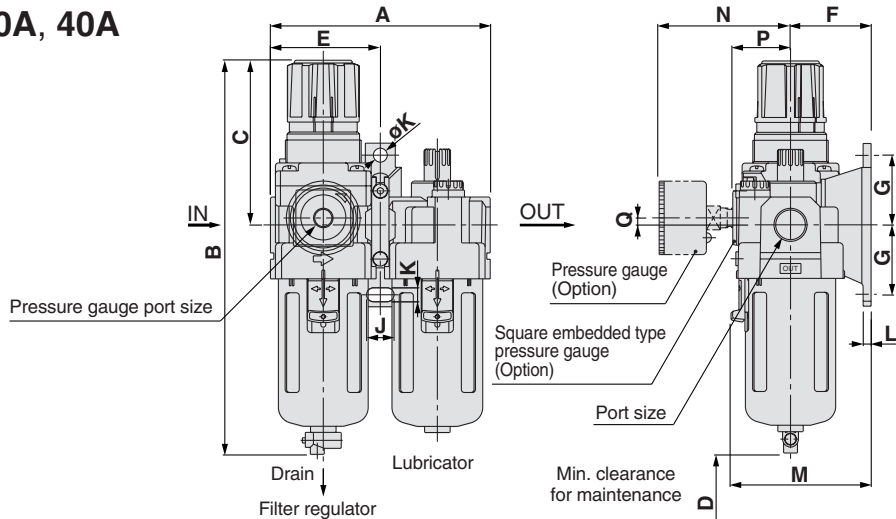

Applicable model	AC10A, AC20A		AC30A, AC40A, AC40A-06				
Optional specifications	With auto drain (N.C.)	Metal bowl	With auto drain (N.O./N.C.)	Metal bowl	Metal bowl with level gauge	With drain guide	Drain cock with barb fitting
			 N.O.: Black N.C.: Gray ø10 One-touch fitting			 1/4 Width across flats 17	 Barb fitting Applicable tubing: T0604

Model	Port size	Standard specification											Accessory specification					
		A	B	C	D	Bracket mounting size							With pressure gauge	With auto drain				
						E	F	G	H	J	K	øK			L	M	N	P
AC10A	M5 x 0.8	56	108	48	35	28	25	20	27	7	4.5	4.5	2.8	40	26	-	0	126
AC20A	1/8, 1/4	83	160	73	60	41.5	30	24	33	12	5.5	5.5	3.2	50	63	27	5	177
AC30A	1/4, 3/8	110	201	86	80	55	41	35	-	14	7	7	4	71	66	30.5	3.5	242
AC40A	1/4, 3/8, 1/2	145	239	92	110	72.5	50	40	-	18	9	9	4	88	76	38.5	1.5	278
AC40A-06	3/4	155	242	93	110	77.5	50	40	-	18	9	9	4.6	88	76	38.5	1.2	278

Model	Optional specification ^{Note 1)}			
	With barb fitting	With drain guide	Metal bowl	Metal bowl with level gauge
	B	B	B	B
AC10A	-	-	107	-
AC20A	-	-	160	-
AC30A	209	208	214	234
AC40A	247	246	251	272
AC40A-06	250	249	255	275

Note 1) For optional specifications (with barb fitting, with drain guide, with metal bowl, or with level gauge), the total length (dimension for B) will vary.

F.R.L. Unit Air Filter + Regulator AC10B to 60B

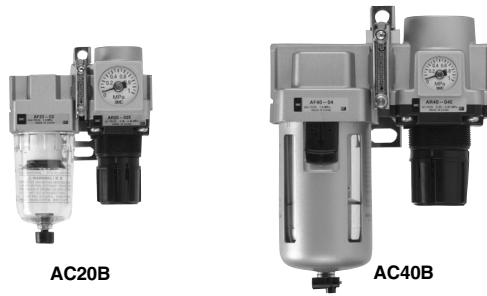

Standard Specifications

Model	AC10B	AC20B	AC25B	AC30B	AC40B	AC40B-06	AC50B	AC55B	AC60B	
Component	Air filter	AF10	AF20	AF30	AF30	AF40	AF40-06	AF50	AF60	AF60
	Regulator	AR10	AR20	AR25	AR30	AR40	AR40-06	AR50	AR50	AR60
Port sizes	M5 x 0.8	1/8 1/4	1/4 3/8	1/4 3/8	1/4 3/8	1/4 3/8 1/2	3/4	3/4 1	1	1
Pressure gauge port size ^{Note 1)}	1/16	1/8	1/8	1/8	1/8	1/4	1/4	1/4	1/4	1/4
Fluid	Air									
Proof pressure	1.5MPa									
Max. operating pressure	1.0MPa									
Set pressure range	0.05 to 0.7MPa	0.05 to 0.85MPa								
Relief pressure	Set pressure + 0.05MPa ^{Note 2)} [at relief flow rate of 0.1L/min (ANR)]									
Ambient and fluid temperature	-5 to 60°C (with no freezing)									
Nominal filtration rating	5µm									
Bowl material	Polycarbonate									
Bowl guard	—	Option	Standard							
Regulator construction	Relieving type									
Weight (kg)	0.16	0.51	0.55	0.63	1.12	1.16	2.44	2.45	2.54	

Note 1) Pressure gauge connection threads are not required for F.R.L. unit with a square embedded type pressure gauge (AC20B to AC60B).
Note 2) Not applicable to AC10B.

Attachment/Accessory Part No.

Description	Model	Part no.											
		AC10B	AC20B	AC25B	AC30B	AC40B	AC40B-06	AC50B	AC55B	AC60B			
Accessories	Pressure gauge ^{Note 1)}	1.0MPa	Round ^{Note 2)}	G27-10-R1	G36-10-□01	G36-10-□01	G36-10-□01	G46-10-□02	G46-10-□02	G46-10-□02	G46-10-□02	G46-10-□02	G46-10-□02
			Square embedded type	—	GC3-10AS	GC3-10AS	GC3-10AS	GC3-10AS	GC3-10AS	GC3-10AS	GC3-10AS	GC3-10AS	GC3-10AS
	Pressure gauge ^{Note 1)}	0.2MPa	Round ^{Note 2)}	G27-10-R1 ^{Note 3)}	G36-2-□01	G36-2-□01	G36-2-□01	G46-2-□02	G46-2-□02	G46-2-□02	G46-2-□02	G46-2-□02	G46-2-□02
			Square embedded type	—	GC3-2AS	GC3-2AS	GC3-2AS	GC3-2AS	GC3-2AS	GC3-2AS	GC3-2AS	GC3-2AS	GC3-2AS
Float type auto drain ^{Note 4)}	N.O.	—	—	AD38 AD38N ^{Note 7)}	AD38 AD38N ^{Note 7)}	AD48 AD48N ^{Note 7)}	AD48 AD48N ^{Note 7)}	AD48 AD48N ^{Note 7)}	AD48 AD48N ^{Note 7)}	AD48 AD48N ^{Note 7)}	AD48 AD48N ^{Note 7)}	AD48 AD48N ^{Note 7)}	
	N.C.	AD17	AD27	AD37 AD37N ^{Note 7)}	AD37 AD37N ^{Note 7)}	AD47 AD47N ^{Note 7)}	AD47 AD47N ^{Note 7)}	AD47 AD47N ^{Note 7)}	AD47 AD47N ^{Note 7)}	AD47 AD47N ^{Note 7)}	AD47 AD47N ^{Note 7)}	AD47 AD47N ^{Note 7)}	
Spacer		Y100	Y200	Y300	Y300	Y400	Y500	Y600	Y600	Y600	Y600		
Pressure switch ^{Note 6)}		—	IS1000M-20	IS1000M-30	IS1000M-30	IS1000M-40	IS1000M-50	IS1000M-60	IS1000M-60	IS1000M-60	IS1000M-60		
T-interface ^{Note 5)}		Y110-M5	Y210-□01 □02	Y310-□01 □02	Y310-□01 □02	Y410-□02 □03	Y510-□02 □03	Y610-□03 □04	Y610-□03 □04	Y610-□03 □04	Y610-□03 □04		
3-port valve for residual pressure release ^{Note 6)}		—	VHS20-□01 □02	VHS30-□02 □03	VHS30-□02 □03	VHS40-□02 □03 □04	VHS40-□06	VHS50-□06 □10	—	—			
Piping adapter ^{Note 6)}		E100-M5	E200-□01 □02 □03	E300-□02 □03 □04	E300-□02 □03 □04	E400-□02 □03 □04 □06	E500-□06	E600-□06 □10	E600-□06 □10	E600-□06 □10			
Pressure switch with piping adapter ^{Note 6)}		—	IS1000E-20 □01 □02 □03	IS1000E-30 □02 □03 □04	IS1000E-30 □02 □03 □04	IS1000E-40 □02 □03 □04 □06	—	—	—	—			
Cross interface ^{Note 6)}		Y14-M5	Y24-□01 □02	Y34-□01 □02	Y34-□01 □02	Y44-□02 □03	Y54-□03 □04	—	—	—			

Note 1) □ in part numbers for a round pressure gauge indicates a type of connection thread. No indication is necessary for R; however, indicate N for NPT. Contact SMC regarding the connection thread NPT and pressure gauge supply for PSI unit specifications.

Note 2) Includes one O-ring and 2 mounting screws.

Note 3) For 1.0MPa.

Note 4) Minimum operating pressure: N.O. type-0.1MPa; N.C. type-0.1MPa (AD17/27), 0.15MPa (AD37/47).

Note 5) For F.R.L. units, port sizes not in () are for standard application.

Note 6) Separate interfaces are required for modular unit.

Note 7) When "N" is specified in the end of part number of auto drain, applicable tube O.D should be ø3/8".

Dimensions

AC10B, 20B

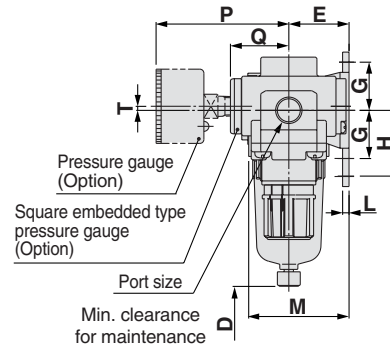
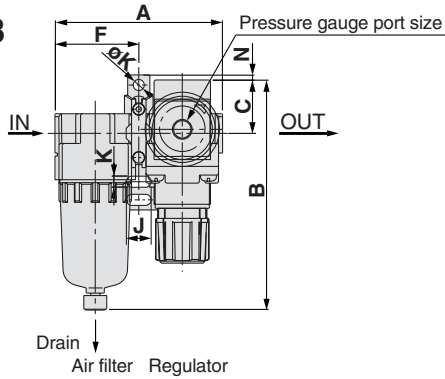

AC25B, 30B, 40B, 50B, 55B, 60B

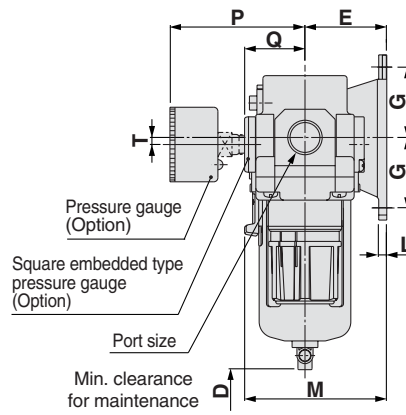
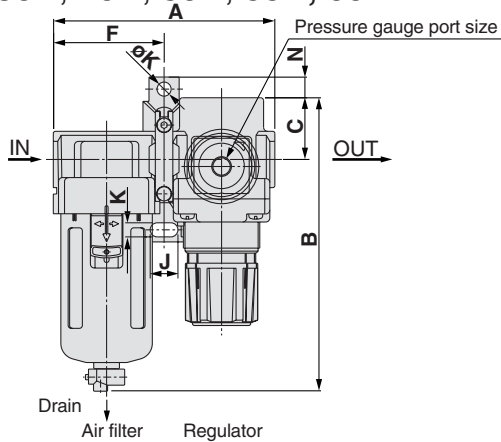

Applicable model	AC10B, AC20B		AC25B, AC30B, AC40B, AC40B-06, AC50B, AC55B, AC60B				
Optional specifications	With auto drain (N.C.)	Metal bowl	With auto drain (N.O./N.C.)	Metal bowl	Metal bowl with level gauge	With drain guide	Drain cock with barb fitting
			 N.O.: Black N.C.: Gray ø10 One-touch fitting			 Width across flats 17	 Barb fitting Applicable tubing: T0604

Model	Port size	Standard specification													Accessory specification				
		A	B	C	D	Bracket mounting size								With pressure gauge		With auto drain			
						E	F	G	H	J	K	ØK	L	M	N	P	Q	T	B
AC10B	M5 x 0.8	56	71	11	25	25	28	20	27	7	4.5	4.5	2.8	40	13.5	26	—	0	89
AC20B	1/8, 1/4	83	114	26.5	40	30	41.5	24	33	12	5.5	5.5	3.2	50	2.5	65	29.5	2	132
AC25B	1/4, 3/8	110	143	28	50	41	55	35	—	14	7	7	4	71	13	64	28.5	0	184
AC30B	1/4, 3/8	110	146	31	50	41	55	35	—	14	7	7	4	71	10	66	30.5	3.5	187
AC40B	1/4, 3/8, 1/2	145	183	36	75	50	72.5	40	—	18	9	9	4	88	12	74	35	3.5	222
AC40B-06	3/4	155	185	36	75	50	77.5	40	—	18	9	9	4.6	88	12	74	35	3	224
AC50B	3/4, 1	186	264	43	20	70	93	50	—	20	11	11	6.4	115	16	84	44.5	3.3	303
AC55B	1	191	277	43	20	70	98	50	—	20	11	11	6.4	117.5	16	84	44.5	3.3	316
AC60B	1	196	280	46	20	70	98	50	—	20	11	11	6.4	117.5	13	84	44.5	3.3	319

Model	Optional specification ^{Note 2)}			
	With barb fitting	With drain guide	Metal bowl	Metal bowl with level gauge
	B	B	B	B
AC10B	—	—	70	—
AC20B	—	—	114	—
AC25B	151	150	156	176
AC30B	154	153	159	179
AC40B	191	190	196	216
AC40B-06	193	192	198	218
AC50B	272	271	277	297
AC55B	285	284	290	310
AC60B	288	287	293	313



Note 1) For AC20 only, the position of the pressure gauge is above the center of the piping.

Note 2) For optional specifications (with barb fitting, with drain guide, with metal bowl, or with level gauge), the total length (dimension for B) will vary.

F.R.L. Unit Air Filter + Mist Separator + Regulator

AC20C to 40C



Page 20



AC20C



AC40C

JIS symbol

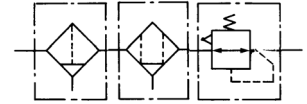

Air filter Mist separator Regulator

Standard Specifications

Model		AC20C	AC25C	AC30C	AC40C	AC40C-06
Component	Air filter	AF20	AF30	AF30	AF40	AF40-06
	Mist separator	AFM20	AFM30	AFM30	AFM40	AFM40-06
	Regulator	AR20	AR25	AR30	AR40	AR40-06
Port sizes		1/8 1/4	1/4 3/8	1/4 3/8	1/4 3/8 1/2	3/4
Pressure gauge port size ^{Note 1)}		1/8	1/8	1/8	1/4	1/4
Fluid		Air				
Proof pressure		1.5MPa				
Maximum operating pressure		1.0MPa				
Minimum operating pressure		0.05MPa				
Set pressure range		0.05 to 0.85MPa				
Rated flow L/min (ANR) ^{Note 2)}		200	450	450	1100	1100
Relief pressure		Set pressure + 0.05MPa [at relief flow rate of 0.1L/min (ANR)]				
Ambient and fluid temperature		-5 to 60°C (with no freezing)				
Nominal filtration rating		AF: 5µm; AFM: 0.3µm (95% filtered particle size)				
Outlet side oil mist concentration		Maximum 1.0mg/m ³ (ANR) (approx. 0.8ppm) ^{Note 3)}				
Bowl material		Polycarbonate				
Bowl guard		Option	Standard			
Filter regulator construction		Relieving type				
Weight (kg)		0.74	0.88	0.95	1.76	1.83



Note 1) Pressure gauge connection threads are not required for F.R.L. unit with a square embedded type pressure gauge (AC20C to AC40C).

Note 2) Conditions: Inlet pressure: 0.7MPa; Set pressure: 0.5MPa. The rated flow varies depending on the inlet pressure.

Note 3) At compressor discharge 30mg/Nm³.

Attachment/Accessory Part No.

Description	Model	Part no.								
		AC20C	AC25C	AC30C	AC40C	AC40C-06				
Accessories	Pressure gauge ^{Note 1)}	1.0MPa	Round	G36-10-□01	G36-10-□01	G36-10-□01	G46-10-□02	G46-10-□02		
		0.2MPa	Square embedded type ^{Note 2)}	GC3-10AS	GC3-10AS	GC3-10AS	GC3-10AS	GC3-10AS		
	Round		G36-2-□01	G36-2-□01	G36-2-□01	G46-2-□02	G46-2-□02			
		Square embedded type ^{Note 2)}	GC3-2AS	GC3-2AS	GC3-2AS	GC3-2AS	GC3-2AS			
Float type auto drain ^{Note 3)}	N.O.	—	AD38	AD38N ^{Note 6)}	AD38	AD38N ^{Note 6)}	AD48	AD48N ^{Note 6)}	AD48	AD48N ^{Note 6)}
	N.C.	AD27	AD37	AD37N ^{Note 6)}	AD37	AD37N ^{Note 6)}	AD47	AD47N ^{Note 6)}	AD47	AD47N ^{Note 6)}
Spacer		Y200	Y300	Y300	Y400	Y500				
Pressure switch ^{Note 5)}		IS1000M-20	IS1000M-30	IS1000M-30	IS1000M-40	IS1000M-50				
T-interface ^{Note 4)} ^{Note 5)}		Y210- □01 □02	Y310- (□01) □02	Y310- (□01) □02	Y410- (□02) □03	Y510- (□02) □03				
3-port valve for residual pressure release ^{Note 5)}		VHS20- □01 □02	VHS30- □02 □03	VHS30- □02 □03	VHS40- □02 □03 □04	VHS40- □06				
Piping adapter ^{Note 5)}		E200- □01 □02 □03	E300- □02 □03 □04	E300- □02 □03 □04	E400- □02 □03 □04 □06	E500- □06				
Pressure switch with piping adapter ^{Note 5)}		IS1000E-20 □01 □02 □03	IS1000E-30 □02 □03 □04	IS1000E-30 □02 □03 □04	IS1000E-40 □02 □03 □04 □06	—				
Cross interface ^{Note 5)}		Y24- □01 □02	Y34- □01 □02	Y34- □01 □02	Y44- □02 □03	Y54- □03 □04				



Note 1) □ in part number for the round pressure gauge indicates a type of connection thread. No indication is necessary for R; however, indicate N for NPT.

Contact SMC regarding the connection thread NPT and pressure gauge supply for PSI unit specifications.

Note 2) Includes one O-ring and 2 mounting screws.

Note 3) Minimum operating pressure: N.O. type-0.1MPa; N.C. type-0.1 MPa (AD27), 0.15MPa (AD37/47).

Note 4) For F.R.L. units, port sizes not in () are for standard application.

Note 5) Separate interfaces are required for modular unit.

Note 6) When "N" is specified in the end of part number of auto drain, applicable tube O.D should be ø3/8".

Dimensions

AC20C

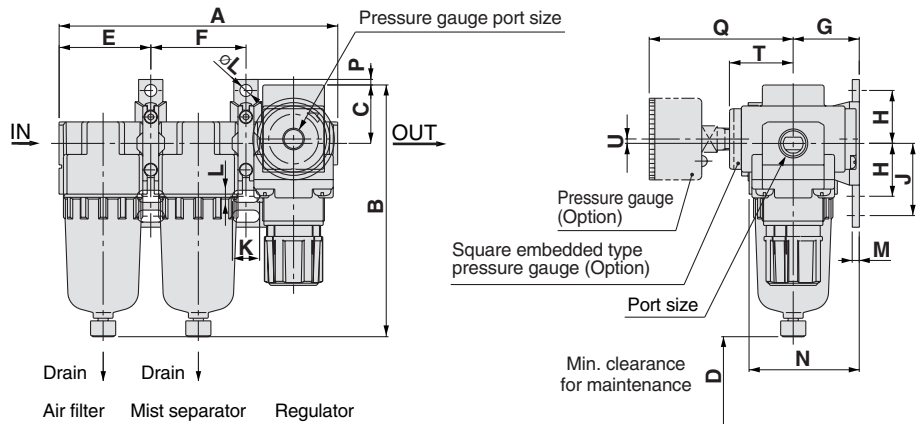

AC25C, 30C, 40C

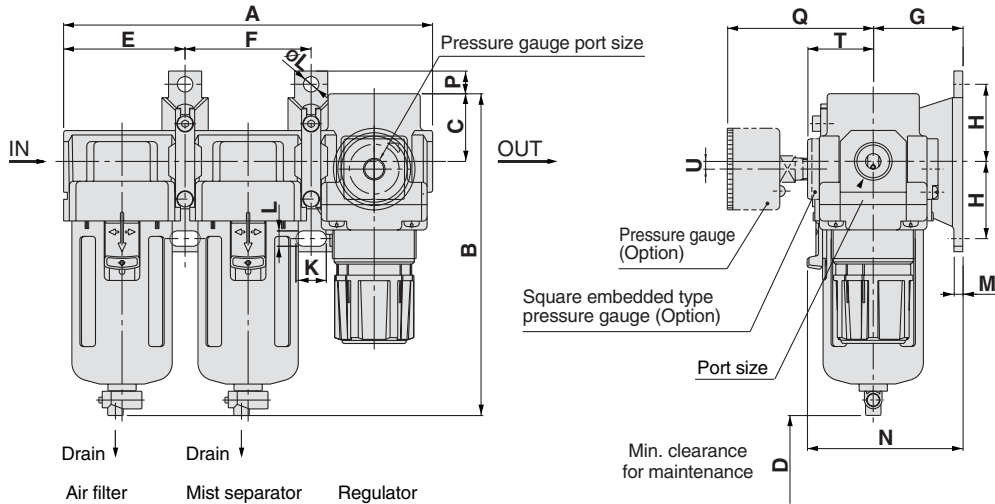

Applicable model	AC20C			AC25C, AC30C, AC40C, AC40C-06										
Optional specifications	With auto drain (N.C.)	Metal bowl	With auto drain (N.O./N.C.)	Metal bowl	Metal bowl with level gauge	With drain guide	Drain cock with barb fitting							

Model	Port size	Standard specification														Accessory specification				
		A	B	C	D	Bracket mounting size										With pressure gauge		With auto drain		
						E	F	G	H	J	K	L	øL	M	N	P	Q	T	U	B
AC20C	1/8, 1/4	126	114	26.5	45	41.5	43	30	24	33	12	5.5	5.5	3.2	50	2.5	65	29.5	2 (Note 1)	132
AC25C	1/4, 3/8	167	143	28	50	55	57	41	35	—	14	7	7	4	71	13	64	28.5	0	184
AC30C	1/4, 3/8	167	146	31	50	55	57	41	35	—	14	7	7	4	71	10	66	30.5	3.5	187
AC40C	1/4, 3/8, 1/2	220	183	36	75	72.5	75	50	40	—	18	9	9	4	88	12	74	35	3.5	222
AC40C-06	3/4	235	185	36	75	77.5	80	50	40	—	18	9	9	4.6	88	12	74	35	3	224

Model	Optional specification (Note 2)			
	With barb fitting	With drain guide	Metal bowl	Metal bowl with level gauge
	B	B	B	B
AC20C	—	—	114	—
AC25C	151	150	156	176
AC30C	154	153	159	179
AC40C	191	190	196	216
AC40C-06	193	192	198	218

Note 1) For AC20 only, the position of the pressure gauge is above the center of the piping.

Note 2) For optional specifications (with barb fitting, with drain guide, with metal bowl, or with level gauge), the total length (dimension for B) will vary.

F.R.L. Unit Filter Regulator + Mist Separator

AC20D to 40D



Page 20

JIS symbol

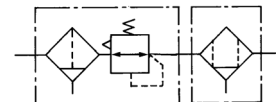

Filter regulator Mist separator

Standard Specifications

Model		AC20D	AC30D	AC40D	AC40D-06
Component	Filter regulator	AW20	AW30	AW40	AW40-06
	Mist separator	AFM20	AFM30	AFM40	AFM40-06
Port sizes		1/8 1/4	1/4 3/8	1/4 3/8 1/2	3/4
Pressure gauge port size ^{Note 1)}		1/8	1/8	1/4	1/4
Fluid		Air			
Proof pressure		1.5MPa			
Maximum operating pressure		1.0MPa			
Minimum operating pressure		0.05MPa			
Set pressure range		0.05 to 0.85MPa			
Rated flow L/min (ANR) ^{Note 2)}		150	330	800	800
Relief pressure		Set pressure + 0.05MPa [at relief flow rate of 0.1L/min (ANR)]			
Ambient and fluid temperature		-5 to 60°C (with no freezing)			
Nominal filtration rating		AW: 5µm; AFM: 0.3µm (95% filtered particle size)			
Outlet side oil mist concentration		Maximum 1.0mg/m ³ (ANR) (approx. 0.8ppm) ^{Note 3)}			
Bowl material		Polycarbonate			
Bowl guard		Option	Standard		
Filter regulator construction		Relieving type			
Weight (kg)		0.57	0.74	1.38	1.43



Note 1) Pressure gauge connection threads are not required for F.R.L. unit with a square embedded type pressure gauge (AC20D to AC40D).

Note 2) Conditions: Inlet pressure: 0.7MPa; Set pressure: 0.5MPa. The rated flow varies depending on the inlet pressure.

Note 3) At compressor discharge of 30mg/Nm³.

Attachment/Accessory Part No.

Description	Model	Part no.							
		AC20D		AC30D		AC40D		AC40D-06	
Accessories	Pressure gauge ^{Note 1)}	1.0MPa	Round	G36-10-□01	G36-10-□01	G46-10-□02	G46-10-□02		
			Square embedded type ^{Note 2)}	GC3-10AS	GC3-10AS	GC3-10AS	GC3-10AS		
	0.2MPa	Round	G36-2-□01	G36-2-□01	G46-2-□02	G46-2-□02			
		Square embedded type ^{Note 2)}	GC3-2AS	GC3-2AS	GC3-2AS	GC3-2AS			
Float type auto drain ^{Note 3)}	N.O.	—	AD38	AD38N ^{Note 6)}	AD48	AD48N ^{Note 6)}	AD48	AD48N ^{Note 6)}	
		N.C.	AD27	AD37	AD37N ^{Note 6)}	AD47	AD47N ^{Note 6)}	AD47	AD47N ^{Note 6)}
Spacer		Y200	Y300		Y400		Y500		
Pressure switch ^{Note 5)}		IS1000M-20	IS1000M-30		IS1000M-40		IS1000M-50		
T-Interface ^{Note 4)} ^{Note 5)}		Y210- ^{□01} _(□02)	Y310- ^{□01} _(□02)		Y410- ^{□02} _(□03)		Y510- ^{□02} _(□03)		
3-port valve for residual pressure release ^{Note 5)}		VHS20- ^{□01} _(□02)	VHS30- ^{□02} _(□03)		VHS40- ^{□02} _(□03) _(□04)		VHS40-□06		
Piping adapter ^{Note 5)}		E200- ^{□01} _(□02) _(□03)	E300- ^{□02} _(□03) _(□04)		E400- ^{□02} _(□03) _(□04) _(□06)		E500-□06		
Pressure switch with piping adapter ^{Note 5)}		IS1000E-20- ^{□01} _(□02) _(□03)	IS1000E-30- ^{□02} _(□03) _(□04)		IS1000E-40- ^{□02} _(□03) _(□04) _(□06)		—		
Cross interface ^{Note 5)}		Y24- ^{□01} _(□02)	Y34- ^{□01} _(□02)		Y44- ^{□02} _(□03)		Y54- ^{□03} _(□04)		



Note 1) □ in part number for the round pressure gauge indicates a type of connection thread. No indication is necessary for R; however, indicate N for NPT.

Contact SMC regarding the connection thread NPT and pressure gauge supply for PSI unit specifications.

Note 2) Includes one O-ring and 2 mounting screws.

Note 3) Minimum operating pressure: N.O. type—0.1MPa; N.C. type—0.1MPa (AD27), 0.15MPa (AD37/47).

Note 4) For F.R.L. units, port sizes not in () are for standard application.

Note 5) Separate interfaces are required for modular unit.

Note 6) When "N" is specified in the end of part number of auto drain, applicable tube O.D should be ø3/8".

Dimensions

AC20D

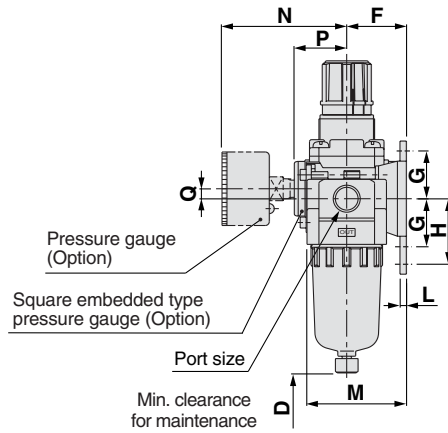
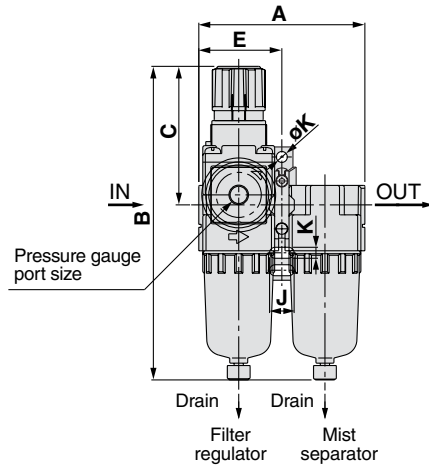

AC30D, 40D

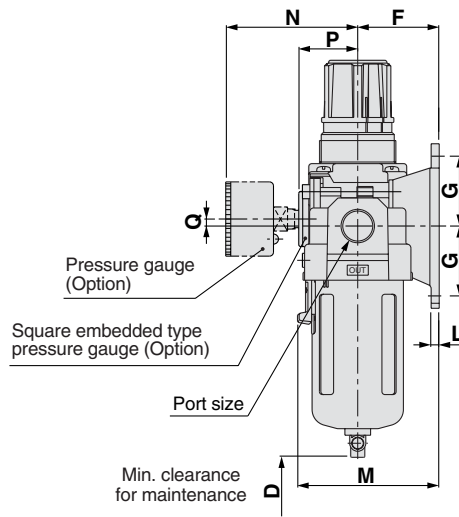
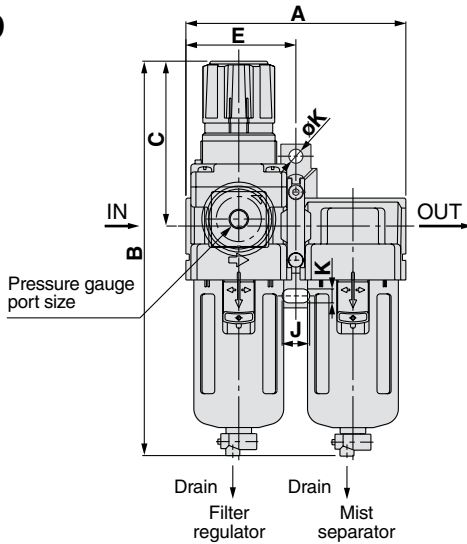

Applicable model	AC20D				AC30D, AC40D, AC40D-06			
Optional specifications	With auto drain (N.C.)	Metal bowl	With auto drain (N.O./N.C.)	Metal bowl	Metal bowl with level gauge	With drain guide	Drain cock with barb fitting	
	M5 x 0.8		N.O.: Black N.C.: Gray ø10 One-touch fitting			1/4 Width across flats 17	Barb fitting Applicable tubing: T0604	

Model	Port size	Standard specification													Accessory specification			
		A	B	C	D	Bracket mounting size								With pressure gauge		With auto drain		
						E	F	G	H	J	K	øK	L	M	N	P	Q	B
AC20D	1/8, 1/4	83	160	73	45	41.5	30	24	33	12	5.5	5.5	3.2	50	63	27	5	177
AC30D	1/4, 3/8	110	201	86	55	55	41	35	—	14	7	7	4	71	66	30.5	3.5	242
AC40D	1/4, 3/8, 1/2	145	239	92	80	72.5	50	40	—	18	9	9	4	88	76	38.5	1.5	278
AC40D-06	3/4	155	242	93	80	77.5	50	40	—	18	9	9	4.6	88	76	38.5	1.2	278

Model	Optional specification ^{Note 1)}			
	With barb fitting	With drain guide	Metal bowl	Metal bowl with level gauge
	B	B	B	B
AC20D	—	—	160	—
AC30D	209	208	214	234
AC40D	247	246	251	272
AC40D-06	250	249	255	275

Note 1) For optional specifications (with barb fitting, with drain guide, with metal bowl, or with level gauge), the total length (dimension for B) will vary.

F.R.L. Unit *Series AC* Attachment Specifications

Piping Adapter (E)

M5 x 0.8, 1/8, 1/4, 3/8, 1/2, 3/4, 1

A piping adapter allows installation/removal of the component without removing the piping and thus makes maintenance easier.

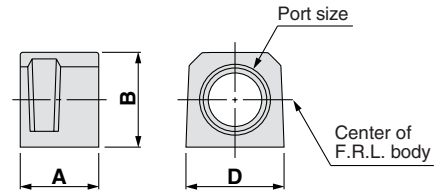
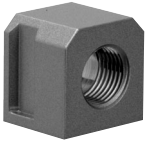

Model ^{Note)}	Port size	A	B	D	Applicable model
E100-M5	M5 x 0.8	10	14	14	AC10□, AW10, AF10, AR10, AL10
E200-□01	1/8	30	23.5	28	AC20□
E200-□02	1/4				AF20, AR20□, AW20□
E200-□03	3/8				AL20, AFM20, AFD20, AWM20, AWD20
E300-□02	1/4	32	30	30	AC25□, AC30□
E300-□03	3/8				AF30, AR30□, AW30□
E300-□04	1/2				AL30, AFM30, AFD30, AWM30, AWD30
E400-□02	1/4	32	36	36	AC40□
E400-□03	3/8				AF40, AR40□, AW40□
E400-□04	1/2				AL40, AFM40, AFD40
E400-□06	3/4				AWM40, AWD40
E500-□06	3/4	32	40	44	AC40□-06, AF40-06, AR40□-06, AW40□-06 AL40-06, AFM40-06, AFD40-06
E600-□06	3/4	35	48	53	AC50, AC55, AC60, AC50B, AC55B, AC60B
E600-□10	1				AF50, AR50□, AL50, AF60, AR60□, AL60

Notes) • □ in model numbers indicates a thread type. No indication is necessary for Rc; however, indicate N for NPT, and F for G.

• Separate interfaces are required for modular unit.

* Factory mounting of a piping adapter on the AC models is available as a special order.

T-interface (T)

M5 x 0.8, 1/8, 1/4, 3/8, 1/2

Using a T-interface facilitates the redirection of air flow.

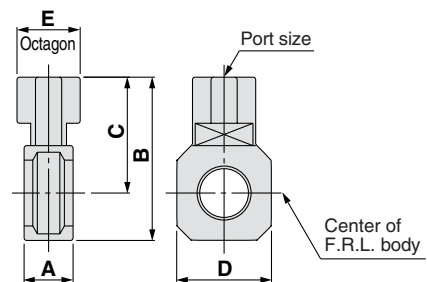
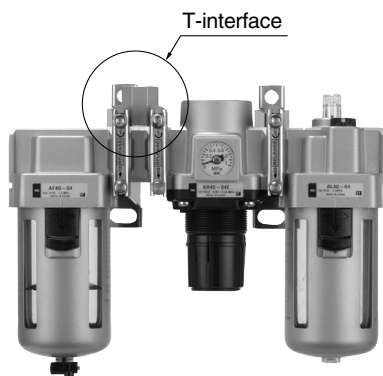
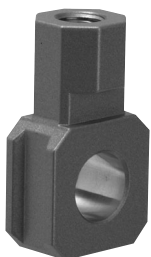

Model	Port size	A	B	C	D	E	Applicable model
Y110-M5	M5 x 0.8	11	19	12	14	8	AC10, AC10B
Y210-□01	1/8	15	42	32	28	19	AC20, AC20B
Y210-□02	1/4						AC20C
Y310-□01	1/8	15	53	39	30	19	AC25, AC25B
Y310-□02	1/4						AC25C, AC30
Y410-□02	1/4	19	62	44	36	24	AC30B, AC30C
Y410-□03	3/8						AC40, AC40B
Y510-□02	1/4	19	66	46	44	24	AC40C
Y510-□03	3/8						AC40-06, AC40B-06
Y610-□03	3/8	22	81	57	53	30	AC40C-06
Y610-□04	1/2						AC50, AC55
							AC60, AC50B
							AC55B, AC60B

Notes) • □ in model numbers indicates a thread type. No indication is necessary for Rc; however, indicate N for NPT, and F for G.

• Separate interfaces are required for modular unit.

* Refer to the attachment table on Front matter 2 for standard port sizes when using with AC.

Caution in Mounting

- If a T-interface is used on the IN side of the lubricator, lubricant may be mixed. Use the series AKM check valve to avoid such possibility.

Pressure Switch with Piping Adapter (P)

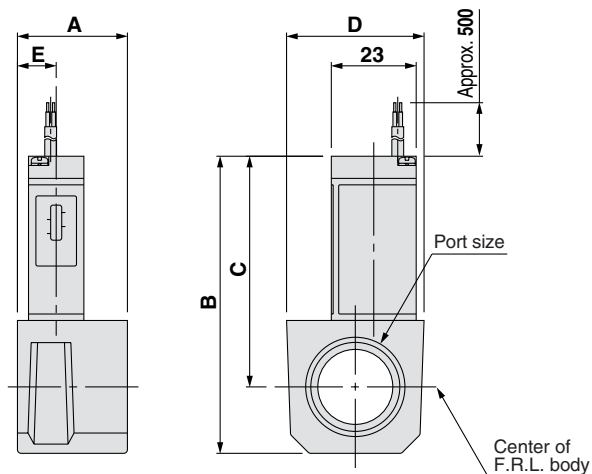
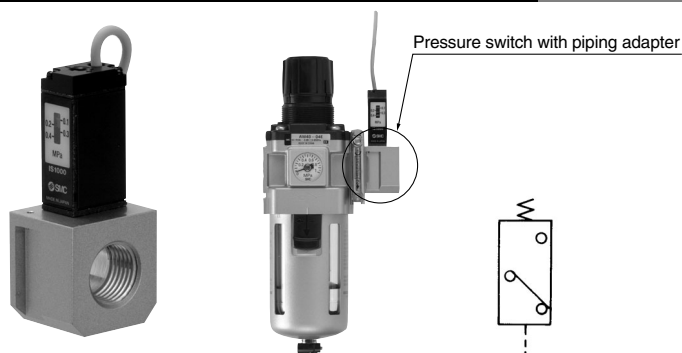

Specifications

Fluid	Air
Proof pressure	1.0MPa
Maximum operating pressure	0.7MPa
Set pressure range (when OFF)	0.1 to 0.4MPa
Differential	0.08MPa
Ambient and fluid temperature	-5 to 60°C (with no freezing)

Switch characteristics

Contact point configuration	1a
Maximum contact point capacity	2VA(AC), 2W(DC)
Operating voltage: AC, DC	100V or less
Max. operating current	12V to 24V AC, DC: 50mA
	48V AC, DC: 40mA
	100V AC, DC: 20mA

Model <small>Note 1)</small>	Port size	A	B	C	D	E	Applicable model
IS1000E-20□01	1/8	30	68	57	28	16	AC20□
IS1000E-20□02	1/4						AR20□, AW20□
IS1000E-20□03	3/8						AWM20, AWD20
IS1000E-30□02	1/4	32	74.5	60.5	30	13	AC25□, AC30□
IS1000E-30□03	3/8						AR25□, AR30□, AW30□
IS1000E-30□04	1/2						AWM30, AWD30
IS1000E-40□02	1/4	32	80.5	62.5	37	12.5	AC40□ <small>Note 2)</small>
IS1000E-40□03	3/8						AR40□, AW40□
IS1000E-40□04	1/2						AWM40, AWD40
IS1000E-40□06	3/4						

Note 1) □ in the model numbers indicates a thread type. No indication is necessary for Rc; however, indicate N for NPT, and F for G.

Note 2) A pressure switch cannot be mounted on AC40□-06 and AW40□-06.

* Separate interfaces are required for modular unit.

** The pressure switch on AC40□-06 and above and AW40□-06 can be mounted by screwing IS1000-01 into the piping adapter E500-□06-X501 or E600-□06-X501 to E600-□06 to 10-X501 (with top-face thread Rc 1/8). Products with a premounted switch are available as a special order. Please contact SMC regarding their availability.

How to Order

IS1000E-30□03□

Pressure switch with piping adapter

Body size

20	For AC20
30	For AC25, AC30
40	For AC40-02 to 04

Thread type

Nil	Rc
N	NPT
F	G

Option

X201	Lead wire length: 3m
X202	Regulating pressure range: 0.1 to 0.6MPa
X207	MPa/PSI Dual scale
X215	Lead wire length: 3m; Regulating pressure range: 0.1 to 0.6MPa
X250	Opposite-side mounting (Left-side mounting type)
X251	Lead wire length: 3m; Opposite-side mounting (Left-side mounting type)
X252	Set pressure range: 0.1 to 0.6MPa; Opposite-side mounting (Left-side mounting type)
X253	Lead wire length: 3m; Regulating pressure range: 0.1 to 0.6MPa; Opposite-side mounting (Left-side mounting type)

This product is for overseas use only according to the new Measurement Law. (The SI unit type is provided for use in Japan.)

Piping adapter port size

Symbol	Port size	Body size		
		20	30	40
01	1/8	●	—	—
02	1/4	●	●	●
03	3/8	●	●	●
04	1/2	—	●	●
06	3/4	—	—	●

Series AC

Check Valve (K) Rc1/8, 1/4, 3/8

A check valve with intermediate air release port can be easily installed to prevent a back flow of lubricant when redirecting the air flow and releasing the air on the outlet side of the regulator.

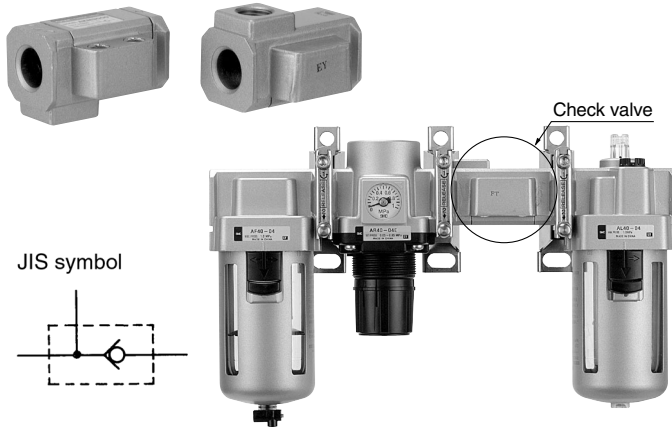

Specifications

Model	Effective area (mm ²)
AKM2000	28
AKM3000	55
AKM4000	111

Be sure to use above check valves when redirecting the air flow on the inlet side of the lubricator. Threads for IN and OUT ports are not machined.

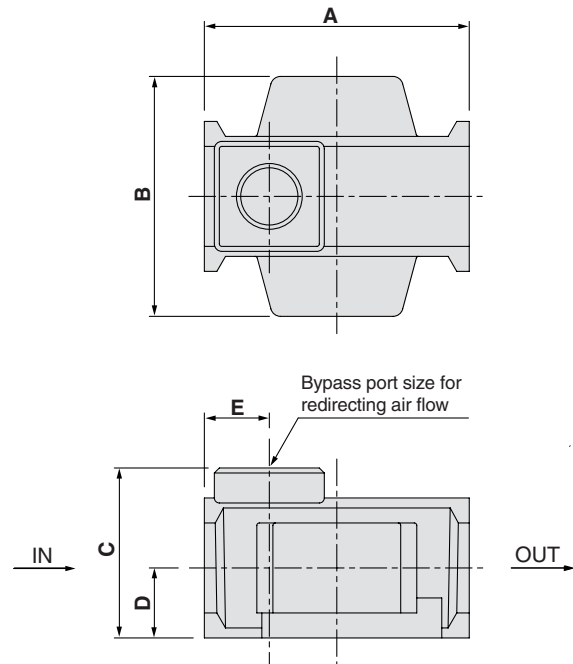

Model	Bypass port sizes	A	B	C	D	E	Applicable model
AKM2000	1/8, 1/4	40	40	28	11	11	AC20, AC20A
AKM3000	1/8, 1/4	53	48	34	14	13	AC25, AC25A AC30, AC30A
AKM4000	1/4, 3/8	70	54	42	18	15	AC40, AC40A ^{Note)}

Note) Not applicable to AC40□-06.

* Refer to the attachment table on page 1 or 5 for standard bypass port sizes applicable to AC.

How to Order

AKM 30 00 - 01

Check valve
Body size
20 30 40

Bypass port size for redirecting air flow

Symbol	Port size	Body size		
		20	30	40
01	1/8	●	●	—
02	1/4	●	●	●
03	3/8	—	—	●

Thread type

Nil	Rc
N	NPT
F	G

Pressure Switch (S)

A compact integrated pressure switch can be easily installed and facilitates the pressure detection of the line.



Specifications

Fluid	Air
Proof pressure	1.0MPa
Maximum operating pressure	0.7MPa
Set pressure range (off)	0.1 to 0.4MPa
Differential	0.08MPa
Ambient and fluid temperature	-5 to 60°C (with no freezing)

Switch characteristics

Contact point configuration	1a
Maximum contact point capacity	2VA(AC), 2W(DC)
Operating voltage: AC, DC	100V or less
Maximum operating current	AC, DC12V to 24V: 50mA AC, DC48V: 40mA AC, DC100V: 20mA

Cross Interface (C)

M5 x 0.8, 1/8, 1/4, 3/8, 1/2

Pipings are possible in all 4 directions.

IN/OUT ports are not machined for threads. Contact SMC if threaded (machined) ports are required.



Cautions in Mounting

- When mounting a cross interface directly on the IN side of the lubricator, be sure to use a series AKM check valve between the lubricator and cross interface.
- Factory mounting of a cross interface on the AC model is available as a special order.

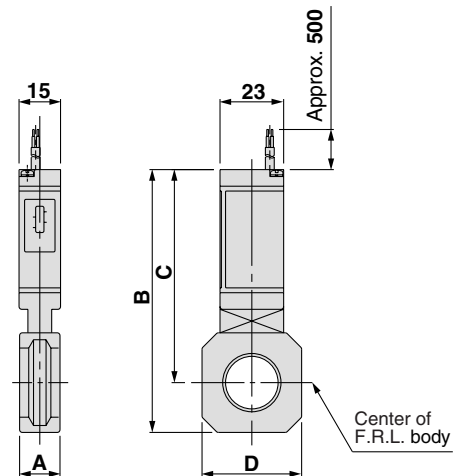

Model	A	B	C	D	Applicable model
IS1000M-20	11	76	66	28	AC20□
IS1000M-30	13	86	72	30	AC25□, AC30□
IS1000M-40	15	95	77	36	AC40□
IS1000M-50	17	99	79	44	AC40□-06
IS1000M-60	22	92.5	68.5	53	AC50□, AC55□, AC60□

Note) Separate interfaces are required for modular unit.

How to Order

IS1000M-30

Pressure switch
Body size

20	For AC20
30	For AC25, AC30
40	For AC40-02 to 04
50	For AC40-06
60	For AC50, AC55, AC60

Accessories

X201	Lead wire length: 3m
X202	Regulating pressure range: 0.1 to 0.6MPa
X207	MPa/PSI Dual scale
X215	Lead wire length: 3m; Regulating pressure range: 0.1 to 0.6MPa

This product is for overseas use only according to the new Measurement Law. (The SI unit type is provided for use in Japan.)

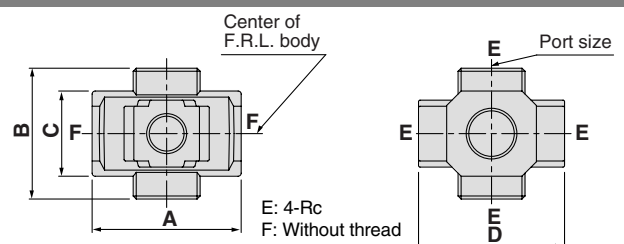

Model	Port size	A	B	C	D	Applicable model
Y14-M5	M5	23	16	14	25	AC10□
Y24-□01	1/8	40	40	22	40	AC20□
Y24-□02	1/4					
Y34-□01	1/8	49	43	28	48	AC25□, AC30□
Y34-□02	1/4					
Y44-□02	1/4	60	48	36	54	AC40□
Y44-□03	3/8					
Y54-□03	3/8	72	62	40	62	AC40□-06
Y54-□04	1/2					

Notes) □ in the model numbers indicates a thread type. No indication is necessary for Rc; however, indicate N for NPT, and F for G.

• If threaded ports are required, they are available as a special order. Contact SMC.

3-Port Valve for Residual Pressure Release (V)

With the use of a 3-port valve for residual pressure release, pressure left in the line can be easily exhausted.

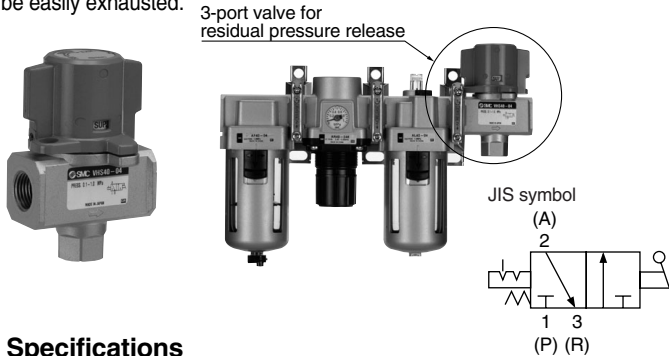

Specifications

Model	Port size		Effective area (mm ²) () Effective Area mm ² (Cv)	
	IN,OUT	EXH.	IN to OUT	OUT to EXH.
VHS20	1/8	1/8	10 (0.54)	11 (0.60)
	1/4		14 (0.76)	16 (0.87)
VHS30	1/4	1/4	16 (0.87)	14 (0.76)
	3/8		31 (1.68)	29 (1.57)
VHS40	1/4	3/8	27 (1.46)	36 (1.95)
	3/8		38 (2.06)	40 (2.17)
	1/2		55 (2.98)	42 (2.28)
VHS40-06	3/4	1/2	77 (1.73)	49 (2.66)
VHS50	3/4	1/2	82 (4.44)	50 (2.71)
	1		125 (6.78)	53 (2.87)

Note) Use an air filter on the IN side for operating protection.

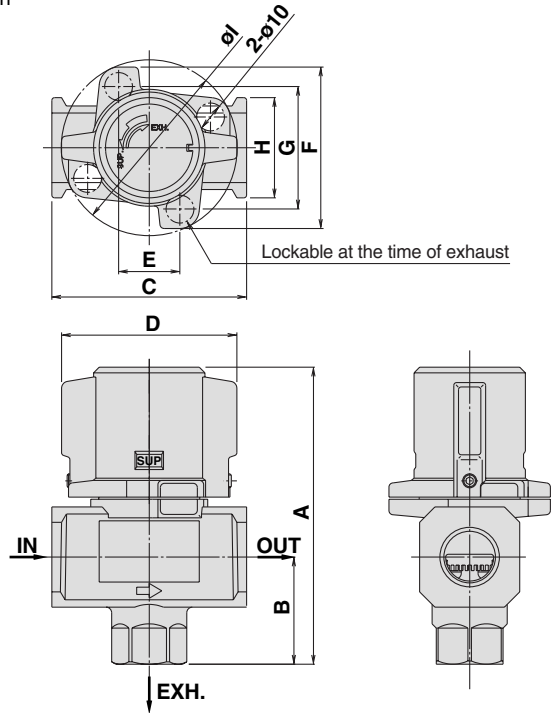

Model	A	B	C	D	E	F	G	H	I
VHS20	59	20	40	34	-	45	33	28	45
VHS30	78	29	53	46	-	55	42	30	55
VHS40	107	39	70	63	22	58	44	36	63
VHS40-06	110	42	75	67	21	65	50	44	69
VHS50	134	53	90	78	26	76	61	54	81

How to Order

VHS 30-F 03-RZ

3-port valve for residual pressure release

Body size

Symbol	Applicable model
20	AC20
30	AC25,30
40	AC40
50	AC50, AC60 ^{Note)}

Note) When the valve is mounted on AC60, the flow rate may decrease depending upon the mounting position.

Thread type

Nil	Rc
N	NPT
F	G

Port size

Symbol	Port size	Body size			
		20	30	40	50
01	1/8	□	—	—	—
02	1/4	□	□	□	—
03	3/8	—	□	□	—
04	1/2	—	—	□	—
06	3/4	—	—	□	□
10	1	—	—	—	□

Optional specifications

Code	Description
R	Flow direction: Right to left
Z ^{Note 1)}	Name plate in imperial units (PSI, °F)

Note 1) This product is for overseas use only according to the new Measurement Law. (The SI unit type is provided for use in Japan.)

Caution

1. Consult SMC when a pressure switch and T type spacer are installed on the outlet of pressure release valve
2. If a stop valve or a silencer is connected to the exhaust port of VHS20/30, the effective sectional area should be larger than the figure indicated in the following table, to prevent malfunction caused by back pressure. (This is not applicable to VHS40 and VHS50)

Model	Effective area (mm ²)
VHS20	5
VHS30	5

Series AC Spacers and Brackets Accessories

Spacer (X)



Y200



Y400

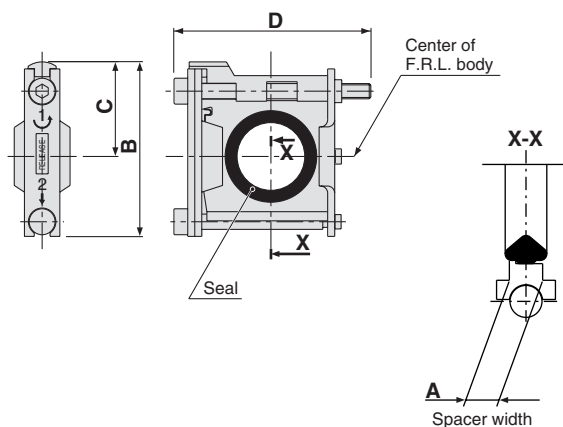

Model	A	B	C	D	Applicable model
Y100	6	27	15	33	AC10, AC10A, AC10B
Y200	3	35.5	18.5	48	AC20□
Y300	4	47	26	59	AC25□, AC30□
Y400	5	57	31	65	AC40□
Y500	5	61	33	70	AC40□-06
Y600	6	75.5	41	86	AC50, AC55, AC60 AC50B, AC55B, AC60B

Replacement parts

Description	Material	Part no.					
		Y100	Y200	Y300	Y400	Y500	Y600
Seal	HNBR ^{Note 2)}	Y100P-060AS ^{Note 1)}	Y200P-060S	Y300P-060S	Y400P-060S	Y500P-060S	Y600P-060S

Note 1) Y-100 comes with 2 O-rings.

Note 2) NBR seal is used for Y100 spacer because of no direct contact with fluid.

Spacer with Bracket (Z)



Y200T



Y400T

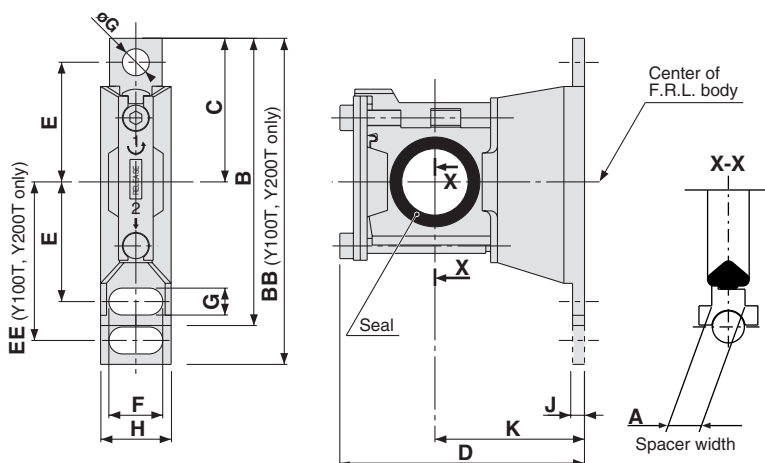

Model	A	B	BB	C	D	E	EE	F	G	øG	H	J	K	Applicable model
Y100T	6	—	56	24.5	40.5	20	27	6.8	4.5	4.5	14	2.8	25	AC10□
Y200T	3	—	67	29	53	24	33	12	5.5	5.5	19	3.2	30	AC20□
Y300T	4	82	—	41	68	35	—	14	7	7	21	4	41	AC25□, AC30□
Y400T	5	96	—	48	81.5	40	—	18	9	9	26	4	50	AC40□
Y500T	5	96	—	48	86	40	—	18	9	9	27	4.6	50	AC40□-06
Y600T	6	120	—	60	112	50	—	20	11	11	31	6.4	70	AC50, AC55, AC60, AC50B, AC55B, AC60B

Replacement parts

Description	Material	Part no.					
		Y100T	Y200T	Y300T	Y400T	Y500T	Y600T
Seal	HNBR ^{Note 2)}	Y100P-060AS ^{Note 1)}	Y200P-060S	Y300P-060S	Y400P-060S	Y500P-060S	Y600P-060S

Note 1) Y-100T comes with 2 O-rings.

Note 2) NBR seal is used for Y100T spacer because of no direct contact with fluid.

Series AC

Mounting Position for Spacer with Bracket

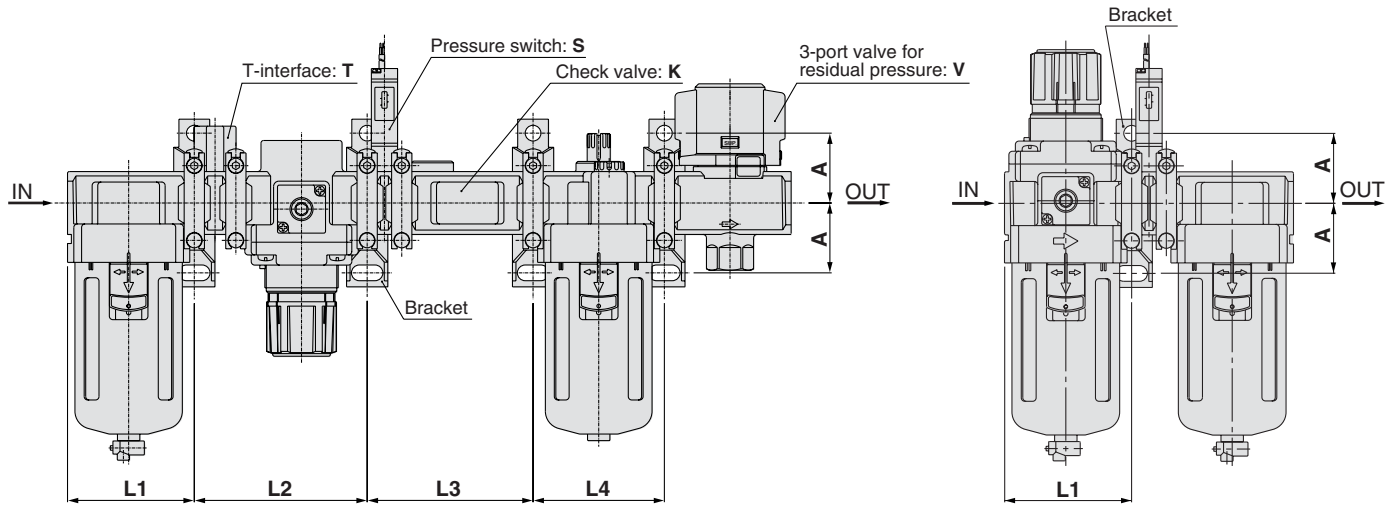

Attachment Model	K			S			T			V			KS			KT			KV				KST		
	L1	L2	L3	L1	L2	L3	L1	L2	L3	L1	L2	L3	L1	L2	L3	L1	L2	L3	L1	L2	L3	L4	L1	L2	L3
AC10	—	—	—	—	—	—	28	48	—	—	—	—	—	—	—	—	—	—	—	—	—	—	—	—	
AC20	41.5	43	43	41.5	43	41.5	61	41.5	43	43	41.5	43	57	41.5	61	43	41.5	43	43	43	41.5	61	57		
AC25	55	57	57	55	57	55	76	55	57	57	55	57	74	55	76	57	55	57	57	57	55	76	74		
AC30	55	57	57	55	57	55	76	55	57	57	55	57	74	55	76	57	55	57	57	57	55	76	74		
AC40	72.5	75	75	72.5	75	72.5	99	72.5	75	75	72.5	75	95	72.5	99	75	72.5	75	75	75	72.5	99	95		
AC40-06	—	—	—	77.5	80	77.5	104	77.5	80	80	—	—	—	—	—	—	—	—	—	—	—	—	—		
AC50	—	—	—	93	96	93	124	93	96	96	—	—	—	—	—	—	—	—	—	—	—	—	—		
AC55	—	—	—	98	96	98	124	—	—	—	—	—	—	—	—	—	—	—	—	—	—	—	—		
AC60	—	—	—	98	101	98	129	—	—	—	—	—	—	—	—	—	—	—	—	—	—	—	—		

Attachment Model	KSV				KTV				KSTV				ST		SV			STV			TV		
	L1	L2	L3	L4	L1	L2	L3	L4	L1	L2	L3	L4	L1	L2	L1	L2	L3	L1	L2	L3	L1	L2	L3
AC10	—	—	—	—	—	—	—	—	—	—	—	—	—	—	—	—	—	—	—	—	—	—	—
AC20	41.5	43	57	43	41.5	61	43	43	41.5	61	57	43	41.5	61	41.5	43	57	41.5	61	57	41.5	61	43
AC25	55	57	74	57	55	76	57	57	55	76	74	57	55	76	55	57	74	55	76	74	55	76	57
AC30	55	57	74	57	55	76	57	57	55	76	74	57	55	76	55	57	74	55	76	74	55	76	57
AC40	72.5	75	95	75	72.5	99	75	75	72.5	99	95	75	72.5	99	72.5	75	95	72.5	99	95	72.5	99	75
AC40-06	—	—	—	—	—	—	—	—	—	—	—	—	—	77.5	104	77.5	80	102	77.5	104	102	77.5	104
AC50	—	—	—	—	—	—	—	—	—	—	—	—	—	93	124	93	96	124	93	124	93	124	96
AC55	—	—	—	—	—	—	—	—	—	—	—	—	—	98	124	—	—	—	—	—	—	—	—
AC60	—	—	—	—	—	—	—	—	—	—	—	—	—	98	129	—	—	—	—	—	—	—	—

Attachment Model	K		S		V		KS		KV			KSV			SV	
	L1	L2	L1	L2	L1	L2	L1	L2	L1	L2	L3	L1	L2	L3	L1	L2
AC20A	41.5	43	41.5	41.5	43	41.5	57	41.5	43	43	41.5	57	43	41.5	57	
AC30A	55	57	55	55	57	55	74	55	57	57	55	74	57	55	74	
AC40A	72.5	75	72.5	72.5	75	72.5	95	72.5	75	75	72.5	95	75	72.5	95	
AC40A-06	—	—	77.5	77.5	80	—	—	—	—	—	—	—	—	77.5	102	

Attachment Model	S		T		V		SV		TV	
	L1	L1	L1	L2	L1	L2	L1	L2	L1	L2
AC10B	—	28	—	—	—	—	—	—	—	—
AC20B	41.5	41.5	41.5	43	41.5	57	41.5	61	—	—
AC25B	55	55	55	57	55	74	55	76	—	—
AC30B	55	55	55	57	55	74	55	76	—	—
AC40B	72.5	72.5	72.5	75	72.5	95	72.5	99	—	—
AC40B-06	77.5	77.5	77.5	80	77.5	102	77.5	104	—	—
AC50B	93	93	93	96	93	124	93	124	—	—
AC55B	98	98	—	—	—	—	—	—	—	—
AC60B	98	98	—	—	—	—	—	—	—	—

Attachment Model	S		T		V			SV			TV		
	L1	L2	L1	L2	L1	L2	L3	L1	L2	L3	L1	L2	L3
AC20C	41.5	43	41.5	43	41.5	43	43	41.5	43	57	41.5	43	61
AC25C	55	57	55	57	55	57	57	55	57	74	55	57	76
AC30C	55	57	55	57	55	57	57	55	57	74	55	57	76
AC40C	72.5	75	72.5	75	72.5	75	75	72.5	75	95	72.5	75	99
AC40C-06	77.5	80	77.5	80	77.5	80	80	77.5	80	102	77.5	80	104

Attachment Model	S		V		SV	
	L1	L1	L2	L1	L2	L1
AC20D	41.5	41.5	43	41.5	57	—
AC30D	55	55	57	55	74	—
AC40D	72.5	72.5	75	72.5	95	—
AC40D-06	77.5	77.5	80	77.5	102	—

L1: Dimensions from the end of the IN side to the center of the mounting hole for the first bracket.
 L2: Mounting hole pitch between the first and the second bracket.
 L3: Mounting hole pitch between the second and the third bracket.
 L4: Mounting hole pitch between the third and the fourth bracket.
 Refer to dimensions pages for dimension A from the center of the piping and the mounting hole.

F.R.L. Unit AC20 to 60 Made to Order Specifications

Contact SMC for detailed dimensions, specifications, and lead times.



With Digital Pressure Switch

AC20 to 60 with a digital pressure switch (Model: ISE30-□□-□□-□L) can be ordered. A digital pressure switch is mounted on the connection threads for the pressure gauge of the regulator or the filter regulator.



Specifications

Part no.		-X465
Pressure switch	Model	ISE30-□□-□□-□L
	Set pressure range	-0.1 to 1 MPa
	Set/Display resolution	0.001 MPa
	Power supply voltage	12 to 24VDC ±10%, Ripple (p-p) 10% or less (with reverse connection protection)
	Current consumption	45mA or less (70mA or less during current output)

* Pressure gauge port size: Rc 1/8

Applicable models

Model	AC20□	AC25□	AC30□	AC40□	AC40□-06	AC50□	AC55□	AC60□
Port sizes	1/8	1/4	1/4	1/4	3/4	3/4	1	1
	1/4	3/8	3/8	3/8 1/2		1		

How to Order → Refer to the next page.

How to Order

AC 30 A F 03 D KV 12R X465 A

Air combination

Body size

20	25	30	40	50	55	60
----	----	----	----	----	----	----

Switch specifications

Symbol	Output specification
A	NPN output
B	PNP output
C	1 to 5V output
D	4 to 20mA output

With digital pressure switch (Series ISE30) Note 11

Note 11 Digital pressure switch is not mounted and is supplied loose at the time of shipment.

Description

Symbol	Description	Applicable model
1 <small>Note 8</small>	0.02 to 0.2MPa setting	AC20□ to 60□
2	Metal bowl	AC20□ to 60□
3	Lubricator with drain cock	AC20□ to 60□
6	Nylon bowl (including sight dome)	AC20□ to 60□
8	Metal bowl with level gauge	AC25□ to 60□
C	With bowl guard	AC20□
J <small>Note 9</small>	Drain guide 1/4	AC25□ to 60□
N	Non-relieving type	AC20□ to 60□
R	Flow direction: Right to left	AC20□ to 60□
W	Drain cock with barb fitting: $\phi 6 \times \phi 4$ nylon tubing	AC25□ to 60□
Z <small>Note 10</small>	Name plate and caution plate for bowl in imperial units (PSI, °F)	AC20□ to 60□

* When more than one specification is required, indicate in ascending alphanumeric order.

Note 8 The only difference from the standard specifications is the adjusting spring for the regulator. It does not restrict the setting of 0.2MPa or more.

Note 9 Without a valve function.

Note 10 For thread type NPT.

This product is for overseas use only according to the new Measurement Law. (The SI unit type is provided for use in Japan.)

Model combination

Symbol	Combination				
	Air filter	Regulator	Lubricator	Filter Regulator	Mist Separator
Nil	①	②	③	—	—
A	—	—	②	①	—
B	①	②	—	—	—
C	①	③	—	—	②
D	—	—	—	①	②

Note 1 The circled numbers indicate the order in which the units are assembled.

Thread type

Nil	Rc
N <small>Note 2</small>	NPT
F <small>Note 3</small>	G

Note 2 Drain guide is NPT1/4 (applicable to AC25 to 60), and the exhaust port for auto drain comes with $\phi 3/8$ " One-touch fitting (applicable to AC25 to 60).

Note 3 Drain guide is G1/4 (applicable to AC25 to 60).

Port size

Symbol	Port size	Body size							
		20	25	30	40	50	55	60	
01	1/8	●	—	—	—	—	—	—	
02	1/4	●	●	●	—	—	—	—	
03	3/8	—	●	●	●	—	—	—	
04	1/2	—	—	—	●	—	—	—	
06	3/4	—	—	—	●	●	—	—	
10	1	—	—	—	—	●	●	●	

Accessories

Symbol	Description	Applicable model
Nil	—	—
C	With float type auto drain (N.C.) <small>Note 1</small>	AC20□ to 60□
D	With float type auto drain (N.O.) <small>Note 1</small>	AC25□ to 60□

Note 1 Applicable tube O.D for auto drain connection should be $\phi 3/8$ " in case NPT thread port is chosen.

Note 12 Consult SMC for detailed dimensions and available attachments and options.

Note 13 Refer to SMC catalog CAT.ES100-42 for detailed specifications and instructions of digital pressure switch.

Attachment

Symbol	Description	Attachment mounting position	Applicable model	Port size for intermediate air release
Nil	None	—	—	—
K	Check valve	AF+AR+[K]+AL	AC20 to 40	AC20□: 1/8 AC25□: 1/4 AC30□: 1/4 AC40□: 3/8
		AW+[K]+AL	AC20A to 40A	
T	T-interface	AF+[T]+AR+AL	AC20 to 60	AC20□: 1/8 AC25□: 1/4 AC30□: 1/4 AC40□: 3/8 AC50□: 3/8 AC55□: 1/2 AC60□: 1/2
		AF+[T]+AR	AC20B to 60B	
		AF+AFM+[T]+AR	AC20C to 40C	
V	3-port valve for residual pressure release	AF+AR+AL+[V]	AC20 to 50	—
		AW+AL+[V]	AC20A to 40A	
		AF+AR+[V]	AC20B to 50B	
		AF+AFM+AR+[V]	AC20C to 40C	
		AW+AFM+[V]	AC20D to 40D	



* When more than one attachment is required, order in alphabetical order.
* Piping adapter, pressure switch with piping adapter, and cross interface need to be ordered separately.

* Contact SMC when using a pressure switch and T-interface together for AC□B.

* The bracket position varies depending on the T-interface or pressure switch mounting.

Refer to the table on page 19 for standard bracket position.

Modular Type Air Filter Series AF

Air filter Series AF	Model	Port size	Filtration (μm)	Accessory
 <p data-bbox="116 902 379 936">Pages 23 through 27</p>	AF10	M5 x 0.8	5	Bracket Float type auto drain
	AF20	1/8, 1/4		
	AF30	1/4, 3/8		
	AF40	1/4, 3/8, 1/2		
	AF40-06	3/4		
	AF50	3/4, 1		
	AF60	1		
 <p data-bbox="116 1205 379 1238">Pages 29 through 31</p>	AFM20	1/8, 1/4	0.3	Bracket Float type auto drain
	AFM30	1/4, 3/8		
	AFM40	1/4, 3/8, 1/2		
	AFM40-06	3/4		
 <p data-bbox="116 1512 379 1536">Pages 32 through 34</p>	AFD20	1/8, 1/4	0.01	Bracket Float type auto drain
	AFD30	1/4, 3/8		
	AFD40	1/4, 3/8, 1/2		
	AFD40-06	3/4		

Air Filter

AF10 to 60

How to Order

AF 30 - F 03 BD - 2R

Body size
10 20 30 40 50 60

Thread type

Nil	Metric thread (M5)
N Note 1)	Rc
F Note 2)	NPT
	G

Port size

Symbol	Port size	Body size					
		10	20	30	40	50	60
M5	M5	●	—	—	—	—	—
01	1/8	—	●	—	—	—	—
02	1/4	—	●	●	●	—	—
03	3/8	—	—	●	●	—	—
04	1/2	—	—	—	●	—	—
06	3/4	—	—	—	●	●	—
10	1	—	—	—	—	●	●

Accessories

Symbol	Description	Applicable model
Nil	—	—
B Note 3)	With bracket	AF20 to 60
C	Float type Note 4) auto drain (N.C.)	AF10 to 60
D	Float type Note 4) auto drain (N.O.)	AF30 to 60

Optional specifications

Symbol	Description	Applicable model
2	Metal bowl	AF10 to 60
6	Nylon bowl	AF10 to 60
8	Metal bowl with level gauge	AF30 to 60
C	With bowl guard	AF20
J Note 5)	Drain guide 1/4	AF30 to 60
R	Flow direction: Right to left	AF10 to 60
W	Drain cock with barb fitting: ø6 x ø4 nylon tubing	AF30 to 60
Z Note 6)	Name plate and caution plate for bowl in imperial units (PSI, "F)	AF10 to 60

Note 1) Drain guide is NPT1/4 (applicable to AF30 to 60), and the exhaust port for auto drain comes with ø3/8" One-touch fitting (applicable to AF30 to 60).

Note 2) Drain guide is G1/4 (applicable to AF30 to 60).

Note 3) Bracket is not assembled and is supplied loose at the time of shipment.

Note 4) Applicable tube O.D for auto drain connection should be ø3/8" in case NPT thread port is chosen.

* When more than one specification is required, indicate in ascending alphanumeric order.

Note 5) Without a valve function.

Note 6) This product is for overseas use only according to the new Measurement Law. (The SI unit type is provided for use in Japan.)

⊙: Combination available ⊖: Combination not available

○: Varies depending on the model △: Available only with NPT thread

Accessory/Optional specification combinations

Accessory/Optional specifications	Combination	Symbol	Accessory			Optional specification							Applicable filter					
			B	C	D	2	6	8	C	J	R	W	Z	AF10	AF20	AF30 to 60		
Accessories	With bracket	B	⊙	⊙	⊙	⊙	⊙	⊙	⊙	⊙	⊙	⊙	⊙	⊙	⊙	⊙	⊙	
	Float type auto drain (N.C.)	C	⊙	⊙	⊙	⊙	⊙	⊙	⊙	⊙	⊙	⊙	⊙	⊙	⊙	⊙	⊙	
	Float type auto drain (N.O.)	D	⊙	⊙	⊙	⊙	⊙	⊙	⊙	⊙	⊙	⊙	⊙	⊙	⊙	⊙	⊙	
Optional specifications	Metal bowl	-2	⊙	⊙	⊙	⊙	⊙	⊙	⊙	⊙	⊙	⊙	⊙	⊙	⊙	⊙	⊙	
	Nylon bowl	-6	⊙	⊙	⊙	⊙	⊙	⊙	⊙	⊙	⊙	⊙	⊙	⊙	⊙	⊙	⊙	
	Metal bowl with level gauge	-8	⊙	⊙	⊙	⊙	⊙	⊙	⊙	⊙	⊙	⊙	⊙	⊙	⊙	⊙	⊙	
	With bowl guard	-C	⊙	⊙	⊙	⊙	⊙	⊙	⊙	⊙	⊙	⊙	⊙	⊙	⊙	⊙	⊙	
	Drain guide 1/4	-J	⊙	⊙	⊙	⊙	⊙	⊙	⊙	⊙	⊙	⊙	⊙	⊙	⊙	⊙	⊙	
	Flow direction: Right to left	-R	⊙	⊙	⊙	⊙	⊙	⊙	⊙	⊙	⊙	⊙	⊙	⊙	⊙	⊙	⊙	⊙
	Drain cock with barb fitting: ø6 x ø4 nylon tubing	-W	⊙	⊙	⊙	⊙	⊙	⊙	⊙	⊙	⊙	⊙	⊙	⊙	⊙	⊙	⊙	⊙
Name plate and caution plate for bowl in imperial units (PSI, "F)	-Z	△	△	△	△	△	△	△	△	△	△	△	△	△	△	△	△	

Standard specifications

Model	AF10	AF20	AF30	AF40	AF40-06	AF50	AF60
Port sizes	M5 x 0.8	1/8, 1/4	1/4, 3/8	1/4, 3/8, 1/2	3/4	3/4, 1	1
Fluid	Air						
Proof pressure	1.5MPa						
Maximum operating pressure	1.0MPa						
Ambient and fluid temperature	-5 to 60°C (with no freezing)						
Nominal filtration rating	5µm						
Bowl material	Polycarbonate						
Bowl guard	—	Option	Standard				
Drain capacity (cm ³)	2.5	8	25	45	45	45	45
Weight (kg)	0.06	0.18	0.22	0.45	0.49	0.99	1.05

Accessory part no.

Accessory	Applicable model							
	AF10	AF20	AF30	AF40	AF40-06	AF50	AF60	
Bracket assembly Note 1)	—	AF20P-050AS	AF30P-050AS	AF40P-050AS	AF40P-070AS	AF50P-050AS	AF50P-050AS	
Float type auto drain Note 2)	N.O.	—	AD38 AD38N Note 3)	AD48 AD48N Note 3)	AD48 AD48N Note 3)	AD48 AD48N Note 3)	AD48 AD48N Note 3)	
	N.C.	AD17	AD27	AD47 AD47N Note 3)	AD47 AD47N Note 3)	AD47 AD47N Note 3)	AD47 AD47N Note 3)	

Note 1) Assembly includes a bracket and 2 mounting screws.

Note 2) Minimum operating pressure: N.O. type-0.1MPa; N.C. type-0.1MPa (AD17/27) and 0.15MPa (AD37/47).

Note 3) When "N" is specified in the end of part number of auto drain, applicable tube O.D should be ø3/8".



JIS symbol

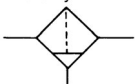

With auto drain

JIS symbol

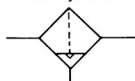

Page 28

Flow Characteristics (Representative values)

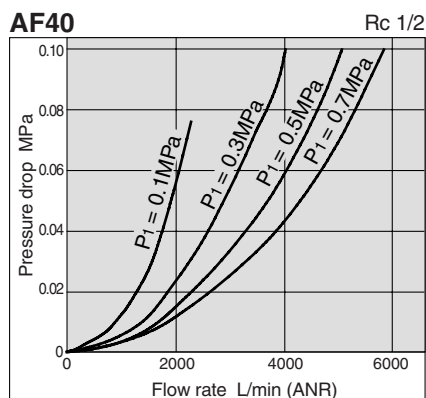
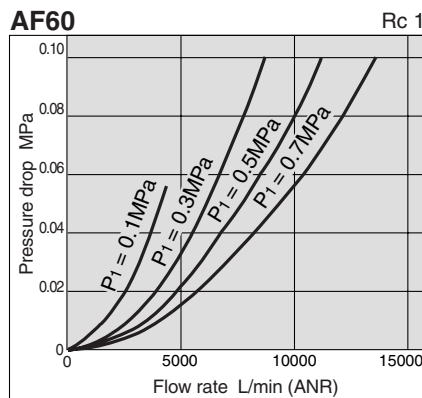
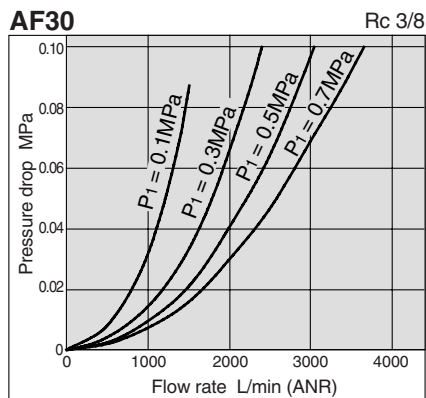
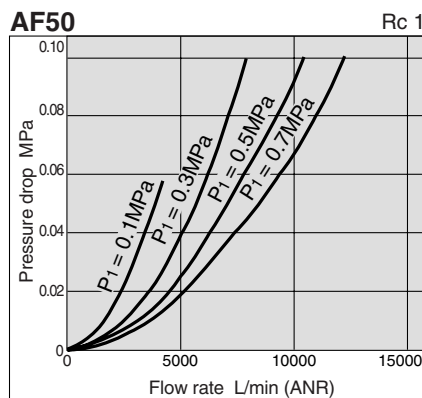
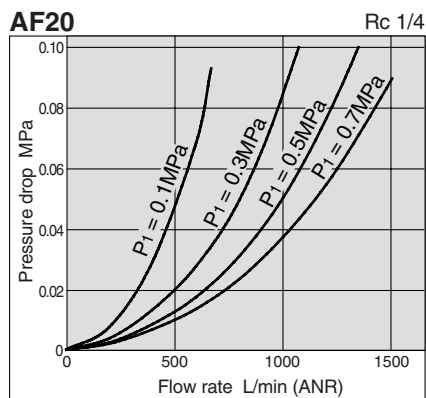
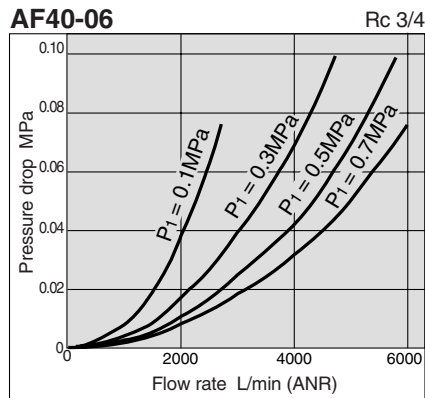
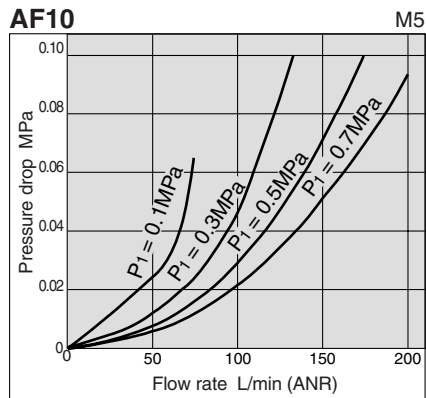

⚠ Specific Product Precautions

- Be sure to read before handling.
- Refer to pages 75 through 78 for safety instructions and F.R.L. unit precautions.

Maintenance

⚠ Warning

1. Replace the element every 2 years or when the pressure drop becomes 0.1MPa, whichever comes first, to prevent damage to the element.

AF10 to 60

Operation Principle: Float Type Auto Drain

N.O. type: AD38, 48

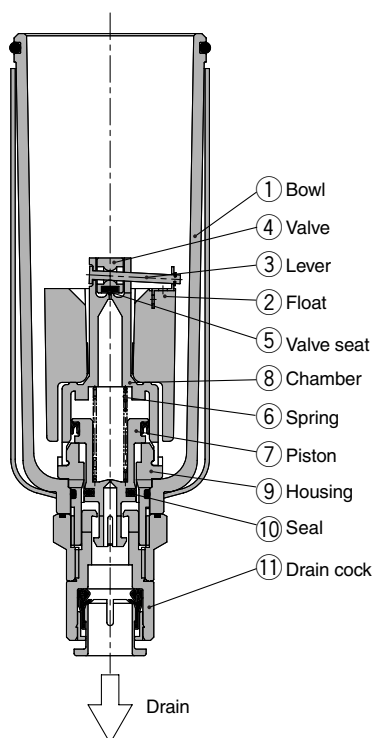

N.C. type: AD37, 47

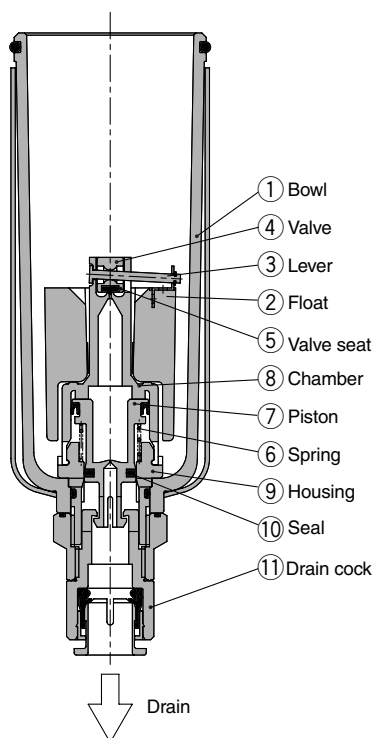

Compact auto drain
N.C. type: AD17, 27

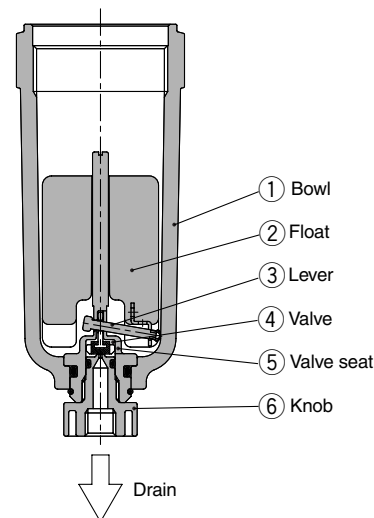

- **When the pressure inside the bowl is released:**

When pressure is released from the bowl ①, piston ⑦ is lowered by spring ⑥.

The sealing action of seal ⑩ is interrupted, and the outside air flows inside the bowl ①, through housing hole ⑨ and drain cock ⑪.

Therefore, if there is an accumulation of condensate in the bowl ①, it will drain out through the drain cock.

- **When pressure is applied inside the bowl:**

When the pressure exceeds 0.1MPa, the force of piston ⑦ surpasses the force of spring ⑥, and the piston goes up.

This pushes seal ⑩ up so that it creates a seal and the inside of the bowl ①, is shut off from the outside air.

If there is no accumulation of condensate in the bowl ①, at this time float ② will be pulled down by its own weight, causing valve ④, which is connected to lever ③, to seal valve seat ⑤.

- **When there is an accumulation of condensate in the bowl:**

Float ② rises due to its own buoyancy and pushes open the seal created by the valve seat, ⑤.

This allows the pressure inside the bowl ①, to enter the chamber ⑧. The result is that the combined pressure inside chamber ⑧ and the force of the spring ⑥, lower the piston ⑦.

This causes the sealing action of seal ⑩ to be interrupted, and the accumulated condensate in the bowl ①, drains out through the drain cock ⑪.

Turning drain cock ⑪ manually counterclockwise lowers piston ⑦, which pushes open the seal created by seal ⑩, thus allowing the condensate to drain out.

- **When the pressure inside the bowl is released:**

Even when pressure inside the bowl ①, is released, spring ⑥ keeps piston ⑦ in its upward position.

This keeps the seal created by the seal ⑩, in place, thus shutting the outside air from inside the bowl ①.

Therefore, even if there should be some condensate accumulation inside the bowl ①, it will not drain out.

- **When pressure is applied inside the bowl:**

Even when pressure is applied inside the bowl ①, the combined force of spring ⑥ and the pressure inside the bowl ①, keeps piston ⑦ in its upward position.

This maintains the seal created by the seal ⑩, in place, thus shutting the outside air from inside the bowl ①.

If there is no accumulation of condensate in the bowl ①, at this time float ② will be pulled down by its own weight, causing valve ④, which is connected to lever ③, to seal valve seat ⑤.

- **When there is an accumulation of condensate in the bowl:**

Float ② rises due to its own buoyancy and pushes open the seal created by the valve seat ⑤. Pressure passes from the bowl to chamber ⑧.

The result is that the pressure inside chamber ⑧ surpasses the force of the spring ⑥, and pushes piston ⑦ downwards.

This causes the sealing action of seal ⑩ to be interrupted and the accumulated condensate in the bowl ①, drains out through the drain cock ⑪.

Turning drain cock ⑪ manually counterclockwise lowers piston ⑦, which pushes open the seal created by seal ⑩, thus allowing the condensate to drain out.

- **When the pressure inside the bowl is released:**

Even when pressure inside the bowl ①, is released, the weight of the float ② causes valve ④, which is connected to lever ③, to seal valve seat ⑤. As a result, the inside of the bowl ①, is shut off from the outside air.

Therefore, even if there is an accumulation of condensate in the bowl ①, it will not drain out.

- **When pressure is applied inside the bowl:**

Even when pressure is applied inside the bowl ①, the weight of the float ②, and the differential pressure that is applied to valve ④ cause valve ④ to seal valve seat ⑤, and the outside air is shut off from the inside of the bowl ①.

- **When the drain is accumulated in the bowl:**

Float ② rises due to its own buoyancy and the seal at valve seat ⑤ is interrupted.

The condensate inside the bowl ① drains out through the knob, ⑥.

Turning knob ⑥ manually counterclockwise lowers it and causes the sealing action of valve seat ⑤ to be interrupted, thus allowing the condensate to drain out.

Construction

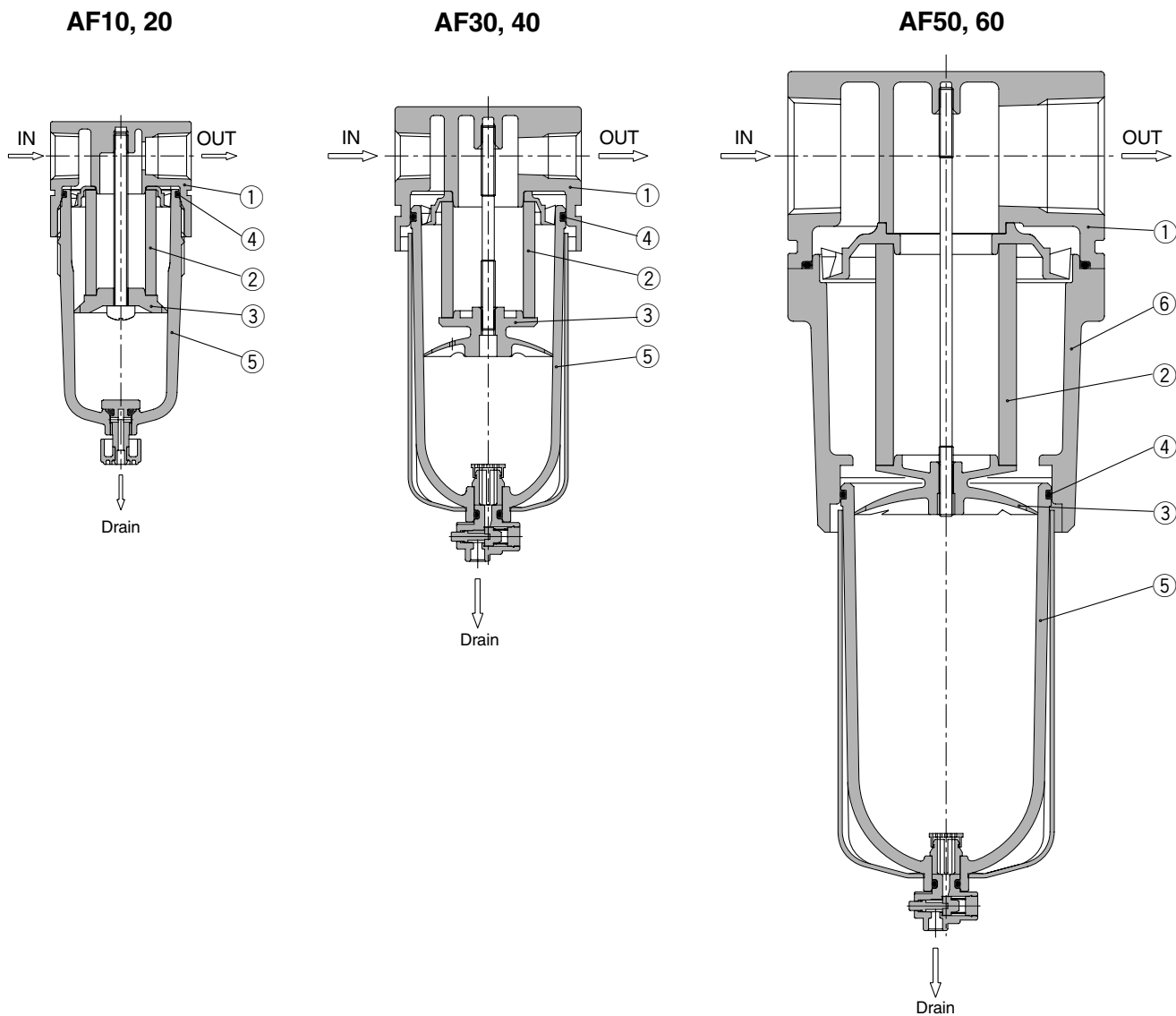

Parts list

No.	Description	Material			Color
		AF10, 20	AF30, 40, 40-06	AF50, 60	
1	Body	Zinc die-cast	Aluminum die-cast		Platinum silver
6	Housing	—		Aluminum die-cast	Platinum silver

Air filter replacement parts

No.	Description	Material	Part no.						
			AF10	AF20	AF30	AF40	AF40-06	AF50	AF60
2	Filter element	Non-woven fabric	AF10P-060S	AF20P-060S	AF30P-060S	AF40P-060S	AF40P-060S	AF50P-060S	AF60P-060S
3	Baffle	PBT	AF10P-040S ^{Note 1)}	AF20P-040S	AF30P-040S	AF40P-040S	AF40P-040S	AF50P-040S	AF60P-040S
4	Bowl O-ring	NBR	C1SFP-260S	C2SFP-260S	C3SFP-260S	C4SFP-260S	C4SFP-260S	C4SFP-260S	C4SFP-260S
5	Bowl assembly ^{Note 2)}	PC	C1SF	C2SF	C3SF ^{Note 3)}	C4SF ^{Note 3)}	C4SF ^{Note 3)}	C4SF ^{Note 3)}	C4SF ^{Note 3)}



Note 1) The material of the baffle for AF10 (AF10P-040S) only is POM.
 Note 2) Contact SMC regarding the bowl assembly supply for PSI and "F" unit specifications.
 Note 3) Bowl assembly for AF30 to 60 models comes with a bowl guard (steel band material).

AF10 to 60

Dimensions

AF10, 20

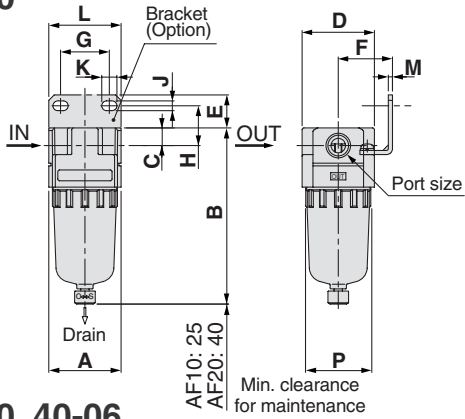

AF50, 60

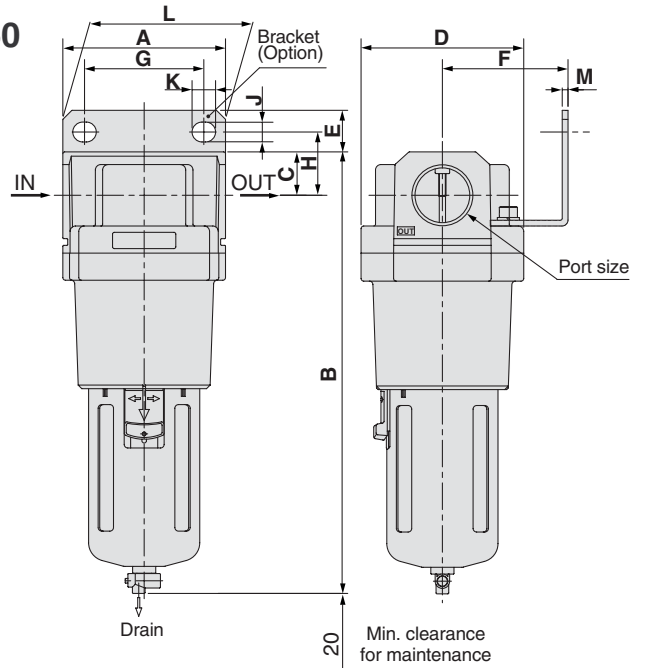

AF30, 40, 40-06

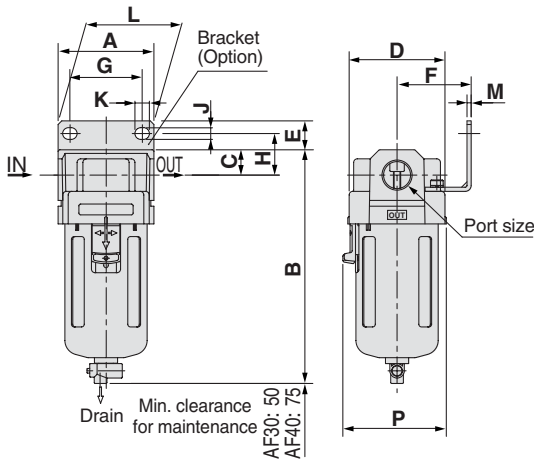

Applicable model	AF10, AF20		AF30, AF40, AF40-06, AF50, AF60				
Optional specifications	With auto drain (N.C.) M5 x 0.8	Metal bowl 	With auto drain (N.O./N.C.) N.O.: Black N.C.: Gray ø10 One-touch fitting	Metal bowl 	Metal bowl with level gauge 	With drain guide 1/4 Width across flats 17	Drain cock with barb fitting Barb fitting Applicable tubing: T0604

Model	Port size	Standard specification					Accessory specification										
		A	B	C	D	P	Bracket mounting size										With auto drain
		E	F	G	H	J	K	L	M	B							
AF10	M5 x 0.8	—	—	—	—	—	—	—	—	—	—	—	—	—	—	—	85
AF20	1/8, 1/4	18	30	27	22	5.4	8.4	40	2.3	115							
AF30	1/4, 3/8	16	41	40	23	6.5	8	53	2.3	170							
AF40	1/4, 3/8, 1/2	17	50	54	26	8.5	10.5	70	2.3	204							
AF40-06	3/4	14	50	54	25	8.5	10.5	70	2.3	208							
AF50	3/4, 1	23	70	66	35	11	13	90	3.2	284							
AF60	1	23	70	66	35	11	13	90	3.2	297							

Model	Optional specification			
	With drain guide	With barb fitting	Metal bowl	Metal bowl with level gauge
	B	B	B	B
AF10	—	—	66	—
AF20	—	—	97	—
AF30	136	137	142	162
AF40	172	173	178	198
AF40-06	176	177	182	202
AF50	252	253	258	278
AF60	265	266	271	291

Air Filter AF20 to 60

Made to Order Specifications

Contact SMC for detailed dimensions, specifications, and lead times.



① Special Temperature Environment

Special materials are used in the manufacturing of seals and resin parts to allow them to withstand various temperature conditions in cold or tropical (hot) climates.

Specifications

Part no.	-X430	-X440
Environment	Low temperature	High temperature
Ambient temperature	-30 to 60°C	-5 to 80°C
Fluid temperature	-5 to 60°C (with no freezing)	
Material	Rubber parts	Special NBR
	Main parts	FPM
	Metal (Aluminum die-cast)	

Applicable models

Model	AF30	AF40	AF40-06	AF50	AF60
Port sizes	1/4 3/8	1/4 3/8 1/2	3/4	3/4 1	1

How to Order

AF 30 F 03 B 2 R X430

Air filter | Body size (30, 40, 50, 60) | Thread type (Nil, Rc, N, NPT, F, G) | Optional specifications (J, R, Z) | Bowl (2) | Option (B)

For high/low temperature
X430 Low temperature
X440 High temperature

Optional specifications

Symbol	Description	Applicable model
J Note 5	Drain guide 1/4	AF30 to 60
R	Flow direction: Right to left	AF30 to 60
Z Note 6	Name plate and caution plate for bowl in imperial units (PSI, °F)	AF30 to 60

* When more than one specification is required, indicate in ascending alphanumeric order.

Note 5) Without a valve function.
Note 6) For thread type NPT. This product is for overseas use only according to the new Measurement Law. (The SI unit type is provided for use in Japan.)

Bowl

Symbol	Description	Applicable model
2 Note 4	Metal bowl	AF30 to 60

Note 4) Only Metal Bowl available.

Option

Symbol	Description	Applicable model
Nil	—	—
B Note 3	With bracket	AF30 to 60

Note 3) Bracket is not assembled and is supplied loose at the time of shipment.

Port size

Symbol	Port size	Body size			
		30	40	50	60
02	1/4	●	●	—	—
03	3/8	●	●	—	—
04	1/2	●	●	—	—
06	3/4	—	●	●	—
10	1	—	—	●	●

Note 1) Drain guide is NPT 1/4 (applicable to AF30 to 60)
Note 2) Drain guide is G1/4 (applicable to AF30 to 60).

② High Pressure

Strong materials are used in the manufacturing of air filters intended for high pressure operation.

Specifications

Part no.	-X425
Proof pressure	3.0MPa
Maximum operating pressure	2.0MPa
Ambient and fluid temperature	-5 to 60°C (with no freezing)

Applicable models

Model	AF20	AF30	AF40	AF40-06	AF50	AF60
Port sizes	1/8 1/4	1/4 3/8	1/4 3/8 1/2	3/4	3/4 1	1

How to Order

AF 30 F 03 B 2 R X425

Air filter | Body size (20, 30, 40, 50, 60) | Thread type (Nil, Rc, N, NPT, F, G) | Optional specifications (J, R, Z) | Bowl (2) | Option (B)

For high pressure

Optional specifications

Symbol	Description	Applicable model
J Note 5	Drain guide 1/4	AF30 to 60
R	Flow direction: Right to left	AF20 to 60
Z Note 6	Name plate and caution plate for bowl in imperial units (PSI, °F)	AF20 to 60

* When more than one specification is required, indicate in ascending alphanumeric order.

Note 5) Without a valve function.
Note 6) For thread type NPT. This product is for overseas use only according to the new Measurement Law. (The SI unit type is provided for use in Japan.)

Bowl

Symbol	Description	Applicable model
2 Note 4	Metal bowl	AF20 to 60
8 Note 3	Metal bowl with level gauge	AF30 to 60

Note 4) Only metal bowl or metal bowl with level gauge available.

Option

Symbol	Description	Applicable model
Nil	—	—
B Note 3	With bracket	AF20 to 60

Note 3) Bracket is not assembled and is supplied loose at the time of shipment.

Port size

Symbol	Port size	Body size				
		20	30	40	50	60
01	1/8	●	—	—	—	—
02	1/4	●	●	—	—	—
03	3/8	—	●	●	—	—
04	1/2	—	—	●	—	—
06	3/4	—	—	●	●	—
10	1	—	—	—	●	●

Note 1) Drain guide is NPT 1/4 (applicable to AF30 to 60)
Note 2) Drain guide is G1/4 (applicable to AF30 to 60).

Note) Contact SMC regarding the detailed dimensions and optional availability.

Mist Separator

AFM20/30/40

How to Order

AFM 30-F 03 BD-2R

Mist separator → **AFM**
 Body size → **30**
 Thread type → **F**
 Port size → **03**
 Accessories → **BD**
 Optional specifications → **2R**

Accessories

Symbol	Description	Applicable model
Nil	—	—
B ^{Note 3)}	With bracket	AFM20 to 40
C	Float type auto drain (N.C.) ^{Note 4)}	AFM20 to 40
D	Float type auto drain (N.O.) ^{Note 4)}	AFM30, 40

Port size

Symbol	Port size	Body size		
		20	30	40
01	1/8	●	—	—
02	1/4	●	●	●
03	3/8	—	●	●
04	1/2	—	—	●
06	3/4	—	—	●

Thread type

Nil	Rc
N ^{Note 1)}	NPT
F ^{Note 2)}	G

Optional specifications

Symbol	Description	Applicable model
2	Metal bowl	AFM20 to 40
6	Nylon bowl	AFM20 to 40
8	Metal bowl with level gauge	AFM30, 40
C	With bowl guard	AFM20
J ^{Note 5)}	Drain guide 1/4	AFM30, 40
R	Flow direction: Right to left	AFM20 to 40
W	Drain cock with barb fitting: ø6 x ø4 nylon tube	AFM30, 40
Z ^{Note 6)}	Name plate and caution plate for bowl in imperial units (PSI, °F)	AFM20 to 40

Note 1) Drain guide is NPT1/4 (applicable to AFM30 and 40), and the exhaust port for auto drain comes with ø3/8" One-touch fitting (applicable to AFM30 and 40).
 Note 2) Drain guide is G1/4 (applicable to AFM30 and 40).
 Note 3) Bracket is not assembled and is supplied loose at the time of shipment.
 Note 4) Applicable tube O.D for auto drain connection should be ø3/8" in case NPT thread port is chosen.
 Note 5) Without a valve function.
 Note 6) For NPT thread type.
 * When more than one specification is required, indicate in ascending alphanumeric order.
 This product is for overseas use only according to the new Measurement Law. (The SI unit type is provided for use in Japan.)

Accessory/Optional specification combinations

Combination	Symbol	Accessory			Optional specification							Applicable mist separator		
		B	C	D	2	6	8	C	J	R	W	Z	AFM20	AFM30 to 40
Accessories														
With bracket	B		○	○	○	○	○	○	○	○	○	○	○	○
Float type auto drain (N.C.)	C	○			○	○	○	○	○	○	○	○	○	○
Float type auto drain (N.O.)	D	○			○	○	○			○		○	○	
Optional specifications														
Metal bowl	-2	○	○	○					○	○		○	○	
Nylon bowl	-6	○	○	○				○	○	○	○	○	○	
Metal bowl with level gauge	-8	○	○	○					○	○		○	○	
With bowl guard	-C	○	○						○			○	○	
Drain guide 1/4	-J	○			○	○	○			○		○	○	
Flow direction: Right to left	-R	○	○	○	○	○	○	○			○	○	○	
Drain cock with barb fitting: ø6 x ø4 nylon tubing	-W	○								○		○	○	
Name plate and caution plate for bowl in imperial units (PSI, °F)	-Z	△	△	△	△	△	△	△	△	△	△	△	△	

○ : Combination available
 ○ : Varies depending on the model
 □ : Combination not available
 △ : Available only with NPT thread



Standard specifications

Model	AFM20	AFM30	AFM40	AFM40-06
Port sizes	1/8 1/4	1/4 3/8	1/4 3/8 1/2	3/4
Fluid	Air			
Proof pressure	1.5MPa			
Maximum operating pressure	1.0MPa			
Minimum operating pressure	0.05MPa			
Ambient and fluid temperature	-5 to 60°C (with no freezing)			
Rated flow L/min (ANR)^{Note 1)}	200	450	1100	1100
Nominal filtration rating	0.3µm (95% filtered particle size)			
Outlet side oil mist concentration	Maximum 1.0 ^m g/m ³ (ANR) (approx. 0.8ppm) ^{Note 2)}			
Bowl material	Polycarbonate			
Bowl guard	option		Standard	
Drain capacity (cm³)	8	25	45	45
Weight (kg)	0.18	0.22	0.44	0.49

Note 1) When the inlet pressure is 0.7MPa. Flow rate varies depending on the inlet pressure.
 Note 2) When the compressor oil mist discharge concentration is 30mg/m³ (ANR).

Accessory part no.

Applicable model	AFM20	AFM30	AFM40	AFM40-06
Accessory				
Bracket assembly^{Note 1)}	AF20P-050AS	AF30P-050AS	AF40P-050AS	AF40P-070AS
Float type auto drain^{Note 2)}	N.O.	AD38	AD48	AD48
	N.C.	AD27	AD47	AD47

Note 1) Assembly includes a bracket and 2 mounting screws.
 Note 2) Minimum operating pressure: N.O. type-0.1MPa; N.C. type-0.1MPa (AD17/27) and 0.15MPa (AD37/47).
 Note 3) When "N" is specified in the end of part number of auto drain, applicable tube O.D should be ø3/8".

JIS symbol

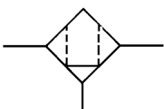

Flow Characteristics (Representative values)

— : When saturated with oil
 - - - : Initial state

AFM20

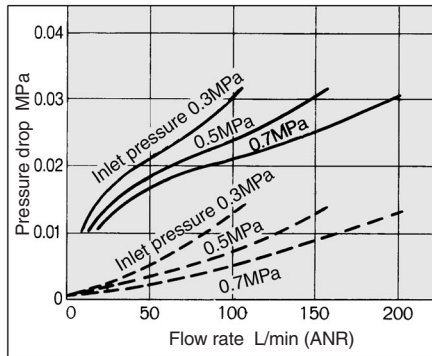

AFM30

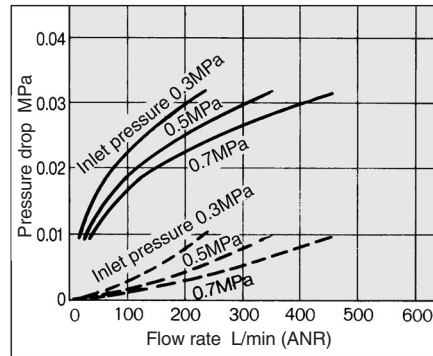

AFM40

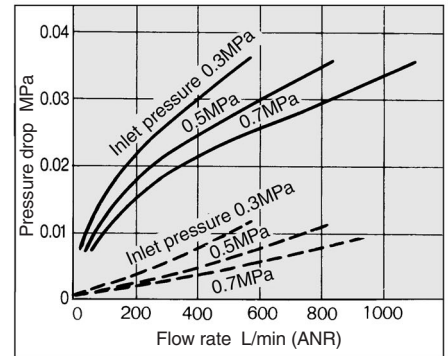

Construction

AFM20

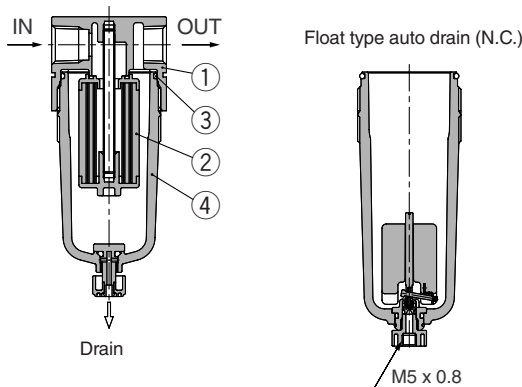

AFM30, 40

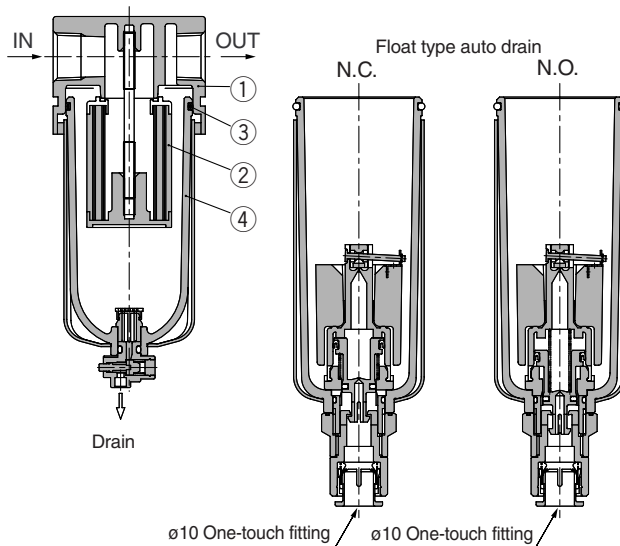

⚠ Specific Product Precautions

Be sure to read before handling. Refer to pages 75 through 78 for safety instructions and F.R.L. unit precautions.

Air Supply

⚠ Caution

1. Install an air filter (Series AF) as a preliminary filter on the inlet side of the mist separator to prevent premature clogging.
2. Do not install on the inlet side of the dryer as this can cause premature clogging of the element.

Maintenance

⚠ Warning

1. Replace the element every 2 years or when the pressure drop becomes 0.1MPa, whichever comes first, to prevent damage to the element.

Design

⚠ Caution

1. Design the system so that the mist separator is installed in a pulsation-free location. The difference between internal and external pressure inside the element should be kept within 0.1MPa, as exceeding this value could cause damage.

Selection

⚠ Caution

1. Do not allow air flow that exceeds the rated flow. If the air flow is allowed outside the range of the rated flow even momentarily, drainage and lubricant may splash at the outlet side or cause damage to the component.
2. Do not use in a low pressure application (such as a blower). F.R.L. unit has its own minimum operating pressure depending on the equipment and is designed specifically to function with compressed air. If used below the minimum operating pressure, a loss of performance and malfunction can occur. Contact SMC if an application under such conditions cannot be avoided.

Parts list

No.	Description	Material		Note
		AFM20	AFM30, AFM40, AFM40-06	
1	Body	Zinc die-cast	Aluminum die-cast	Platinum silver

Replacement parts

No.	Description	Material	Part no.			
			AFM20	AFM30	AFM40	AFM40-06
2	Element assembly	—	AFM20P-060AS	AFM30P-060AS	AFM40P-060AS	AFM40P-060AS
3	Bowl O-ring	NBR	C2SFP-260S	C3SFP-260S	C4SFP-260S	C4SFP-260S
4	Bowl assembly ^{Note 1)}	PC	C2SF	C3SF ^{Note 2)}	C4SF ^{Note 2)}	C4SF ^{Note 2)}

Note 1) Including O-Ring. Contact SMC regarding the bowl assembly supply for PSI and °F unit specifications.
 Note 2) Bowl assembly for AFM30 to AFM40-06 includes a bowl guard (steel band material).

AFM20/30/40

Dimensions

AFM20

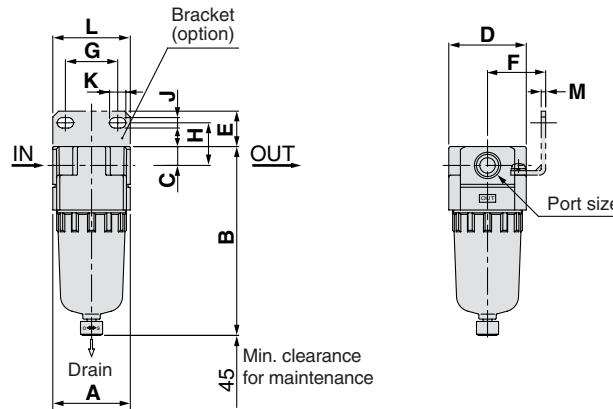

AFM30, 40, 40-06

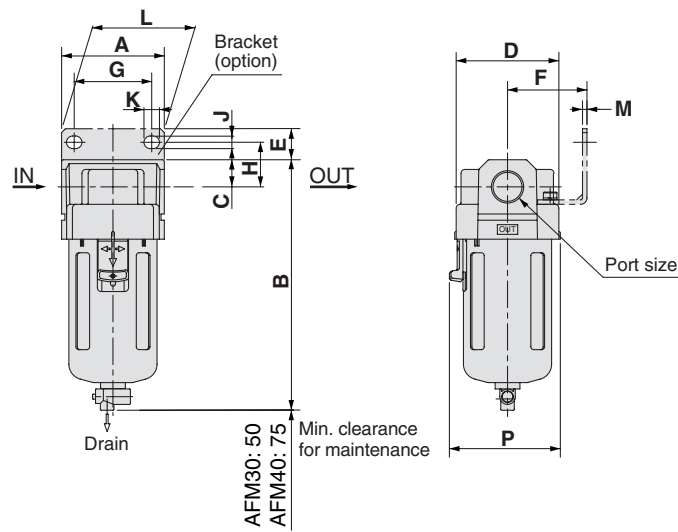

Applicable model	AFM20		AFM30, AFM40, AFM40-06				
	With auto drain (N.C.)	Metal bowl	With auto drain (N.O./N.C.)	Metal bowl	Metal bowl with level gauge	With drain guide	Drain cock with barb fitting
Optional specifications							

Model	Port size	Standard specification					Accessory specification								
							With bracket								
		A	B	C	D	P	E	F	G	H	J	K	L	M	B
AFM20	1/8, 1/4	40	97	10	40	—	18	30	27	22	5.4	8.4	40	2.3	115
AFM30	1/4, 3/8	53	129	14	53	57	16	41	40	23	6.5	8	53	2.3	170
AFM40	1/4, 3/8, 1/2	70	165	18	70	73	17	50	54	26	8.5	10.5	70	2.3	204
AFM40-06	3/4	75	169	20	70	73	14	50	54	25	8.5	10.5	70	2.3	208

Model	Optional specification			
	With drain guide	With barb fitting	Metal bowl	Metal bowl with level gauge
	B	B	B	B
AFM20	—	—	97	—
AFM30	136	137	142	162
AFM40	172	173	178	198
AFM40-06	176	177	182	202

Micro-Mist Separator

AFD20/30/40

How to Order

AFD 30 — F 03 BD — 2R

Micro-mist separator: AFD 30
 Body size: 20 30 40
 Thread type: Nil, Rc, N (Note 1), NPT, F (Note 2), G
 Port size: Symbol, Port size, Body size (20, 30, 40)
 Accessories: Symbol, Description, Applicable model (Nil, B (Note 3), C, D)
 Optional specifications: Symbol, Description, Applicable model (2, 6, 8, C, J (Note 5), R, W, Z (Note 6))

Note 1) Drain guide is NPT1/4 (applicable to AFD30 and 40), and the exhaust port for auto drain comes with ø3/8" One-touch fitting (applicable to AFD30 and 40).
 Note 2) Drain guide is G1/4 (applicable to AFD30 and 40).
 Note 3) Bracket is not assembled and is supplied loose at the time of shipment.
 Note 4) Applicable tube O.D for auto drain connection should be ø3/8" in case NPT thread port is chosen.
 * When more than one specification is required, indicate in ascending alphanumerical order.
 Note 5) Without a valve function. Note 6) For NPT thread type.

Accessory/Optional specification combinations

Combination	Symbol	Accessory			Optional specification								Applicable micro mist separator			
		B	C	D	2	6	8	C	J	R	W	Z	AFD20	AFD30 to 40		
Accessories																
With bracket	B	⊙	○	○	⊙	⊙	○	○	○	⊙	○	△	⊙	⊙		
Float type auto drain (N.C.)	C	⊙	⊙	○	⊙	⊙	○	○	○	⊙	⊙	△	⊙	⊙		
Float type auto drain (N.O.)	D	⊙	⊙	○	⊙	⊙	○	○	○	⊙	⊙	△	⊙	⊙		
Optional specifications																
Metal bowl	-2	⊙	⊙	○	⊙	⊙	○	○	○	⊙	⊙	△	⊙	⊙		
Nylon bowl	-6	⊙	⊙	○	⊙	⊙	○	○	○	⊙	⊙	△	⊙	⊙		
Metal bowl with level gauge	-8	⊙	⊙	○	⊙	⊙	○	○	○	⊙	⊙	△	⊙	⊙		
With bowl guard	-C	⊙	⊙	○	⊙	⊙	○	○	○	⊙	⊙	△	⊙	⊙		
Drain guide 1/4	-J	⊙	⊙	○	⊙	⊙	○	○	○	⊙	⊙	△	⊙	⊙		
Flow direction: Right to left	-R	⊙	⊙	○	⊙	⊙	○	○	○	⊙	⊙	△	⊙	⊙		
Drain cock with barb fitting: ø6 x ø4 nylon tube	-W	⊙	⊙	○	⊙	⊙	○	○	○	⊙	⊙	△	⊙	⊙		
Name plate and caution plate for bowl in imperial units (PSI, °F)	-Z	△	△	△	△	△	△	△	△	△	△	△	△	△		

Standard specifications

Model	AFD20	AFD30	AFD40	AFD40-06
Port size	1/8 1/4	1/4 3/8	1/4 3/8 1/2	3/4
Fluid	Air			
Proof pressure	1.5MPa			
Maximum operating pressure	1.0MPa			
Minimum operating pressure	0.05MPa			
Ambient and fluid temperature	-5 to 60°C (with no freezing)			
Rated flow L/min (ANR) ^{Note 1)}	120	240	600	600
Nominal filtration rating	0.01µm (95% filtered particle size)			
Outlet side oil mist concentration	Max.0.1mg/m ³ (ANR) (before saturated with oil: 0.01mg/m ³ (ANR) or less, approx. 0.008ppm) ^{Note 2)}			
Bowl material	Polycarbonate			
Bowl guard	Option	Standard		
Drain capacity (cm ³)	8	25	45	45
Weight (kg)	0.18	0.22	0.44	0.49

Note 1) When the inlet pressure is 0.7MPa. The flow rate varies depending on the inlet pressure.
 Note 2) When the compressor oil mist discharge concentration is 30mg/m³ (ANR).

Accessory part no.

Accessory	Applicable model			
	AFD20	AFD30	AFD40	AFD40-06
Bracket assembly ^{Note 1)}	AF20P-050AS	AF30P-050AS	AF40P-050AS	AF40P-070AS
Float type auto drain ^{Note 2)}	N.O.	AD38	AD38N ^{Note 3)}	AD48
	N.C.	AD27	AD37N ^{Note 3)}	AD47
			AD48N ^{Note 3)}	AD48N ^{Note 3)}
			AD47N ^{Note 3)}	AD47N ^{Note 3)}

Note 1) Assembly includes a bracket and 2 mounting screws.
 Note 2) Minimum operating pressure: N.O. type=0.1MPa; N.C. type=0.1MPa (AD27) and 0.15MPa (AD37/47).
 Note 3) When "N" is specified in the end of part number of auto drain, applicable tube O.D should be ø3/8".

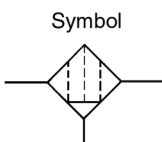

AFD20/30/40

Flow Characteristics (Representative values)

— : When saturated with oil
 - - - : Initial state

AFD 20

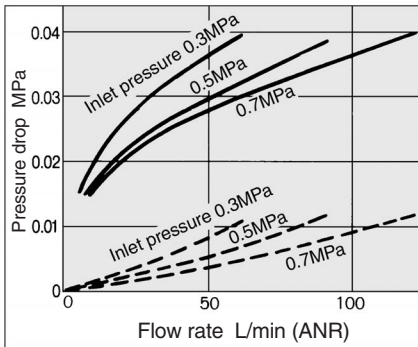

AFD 30

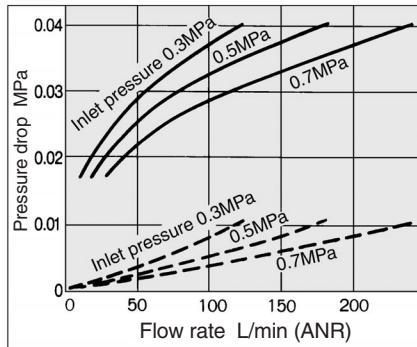

AFD 40

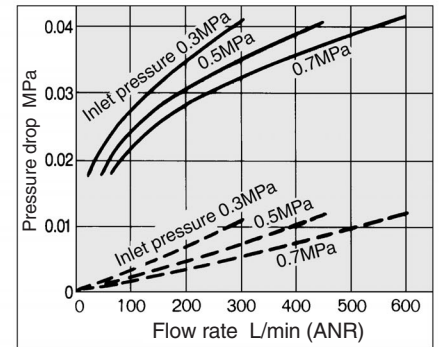

Construction

AFD20

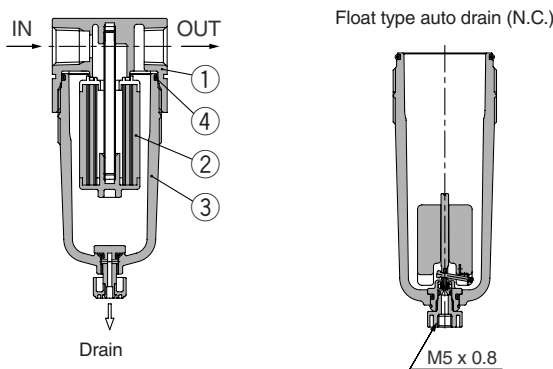

AFD30, 40

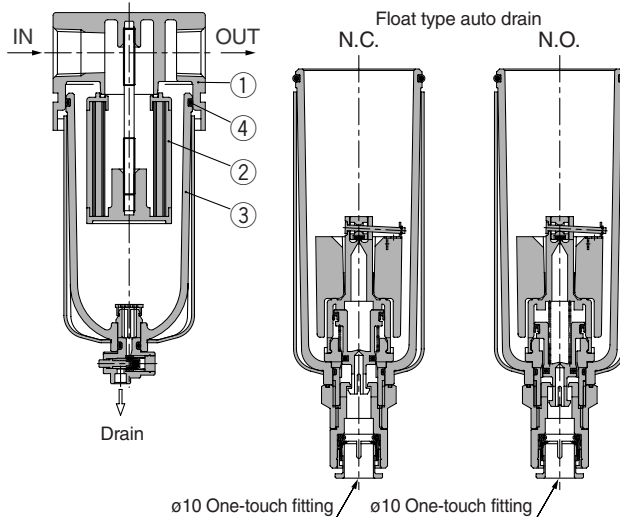

Parts list

No.	Description	Material		Note
		AFD20	AFD30, AFD40, AFD40-06	
1	Body	Zinc die-cast	Aluminum die-cast	Platinum silver

Replacement parts

No.	Description	Material	Part no.			
			AFD20	AFD30	AFD40	AFD40-06
2	Element assembly	—	AFD20P-060AS	AFD30P-060AS	AFD40P-060AS	AFD40P-060AS
3	Bowl assembly ^{Note 1)}	PC	C2SF	C3SF ^{Note 2)}	C4SF ^{Note 2)}	C4SF ^{Note 2)}
4	Bowl O-ring	NBR	C2SFP-260S	C3SFP-260S	C4SFP-260S	C4SFP-260S

Note 1) Including O-Ring. Contact SMC regarding the bowl assembly supply for PSI and °F unit specifications.
 Note 2) Bowl assembly for AFD30 to AFD40-06 includes a bowl guard (steel band material).

Specific Product Precautions

Be sure to read before handling.
 Refer to pages 75 through 78 for safety instructions and F.R.L. unit precautions.

Air Supply

Caution

1. Install a mist separator (Series AFM) as a preliminary filter on the inlet side of the micro-mist separator to prevent premature clogging.
2. Do not install on the inlet side of the dryer as this can cause premature clogging of the element.

Maintenance

Warning

1. Replace the element every 2 years or when the pressure drops becomes 0.1MPa, whichever comes first, to prevent damage to the element.

Design

Caution

1. Design the system so that the mist separator is installed in a pulsation-free location. The difference between internal and external pressure inside the element should be kept within 0.1MPa, as exceeding this value could cause damage.

Selection

Caution

1. Do not allow air flow that exceeds the rated flow. If the air flow is allowed outside the range of the rated flow even momentarily, drainage and lubricant may splash at the outlet side or cause damage to the component.
2. Do not use in a low pressure application (such as a blower). F.R.L. unit has its own minimum operating pressure depending on the equipment and is designed specifically to function with compressed air. If used below the minimum operating pressure, a loss of performance and malfunction can occur. Contact SMC if an application under such conditions cannot be avoided.

Dimensions

AFD20

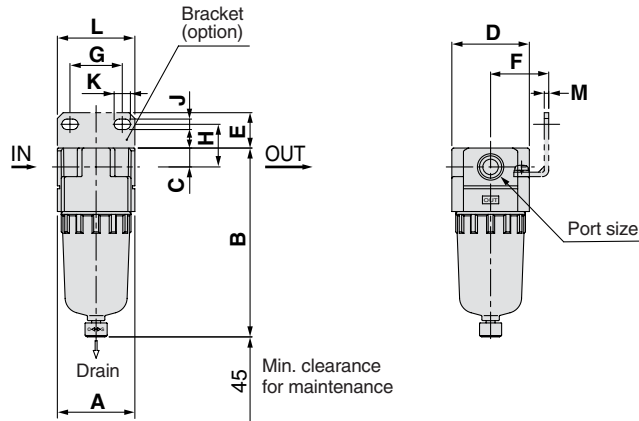

AFD30, 40, 40-06

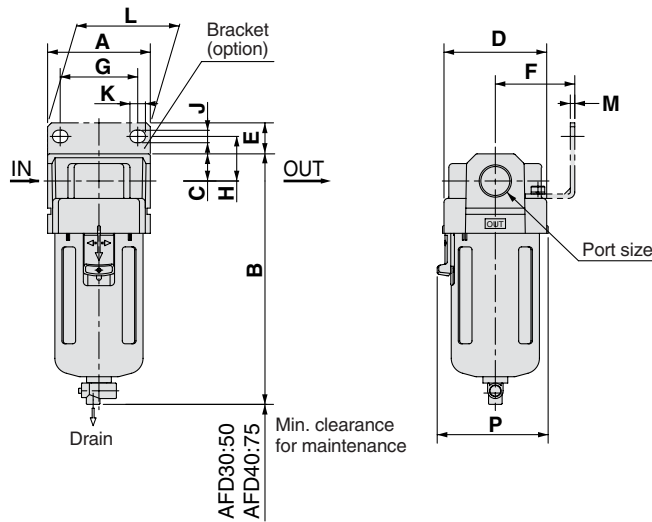



Applicable model	AFD20			AFD30, AFD40, AFD40-06			
Optional specifications	With compact auto drain (N.C.)	Metal bowl	With auto drain (N.O./N.C.)	Metal bowl	Metal bowl with level gauge	With drain guide	Drain cock with barb fitting

Model	Port size	Standard specification					Accessory specification								
		A	B	C	D	P	With bracket							With auto drain	
							E	F	G	H	J	K	L	M	B
AFD20	1/8, 1/4	40	97	10	40	—	18	30	27	22	5.4	8.4	40	2.3	115
AFD30	1/4, 3/8	53	129	14	53	57	16	41	40	23	6.5	8	53	2.3	170
AFD40	1/4, 3/8, 1/2	70	165	18	70	73	17	50	54	26	8.5	10.5	70	2.3	204
AFD40-06	3/4	75	169	20	70	73	14	50	54	25	8.5	10.5	70	2.3	208

Model	Optional specification			
	With drain guide	With barb fitting	Metal bowl	Metal bowl with level gauge
	B	B	B	B
AFD20	—	—	97	—
AFD30	136	137	142	162
AFD40	172	173	178	198
AFD40-06	176	177	182	202

Modular Type Regulator Series AR

Regulator Series AR	Model	Port size	Accessory
 <p data-bbox="140 949 427 981">Pages 36 through 40</p>	AR10	M5 x 0.8	Bracket Square embedded type pressure gauge (except for AR10) Round pressure gauge Panel mount
	AR20	1/8, 1/4	
	AR25	1/4, 3/8	
	AR30	1/4, 3/8	
	AR40	1/4, 3/8, 1/2	
	AR40-06	3/4	
	AR50	3/4, 1	
AR60	1		
 <p data-bbox="140 1375 427 1406">Pages 43 through 48</p>	AR20K	1/8, 1/4	
	AR25K	1/4, 3/8	
	AR30K	1/4, 3/8	
	AR40K	1/4, 3/8, 1/2	
	AR40K-06	3/4	
	AR50K	3/4, 1	
	AR60K	1	

Regulator AR10 to 60

How to Order



AR20



AR40

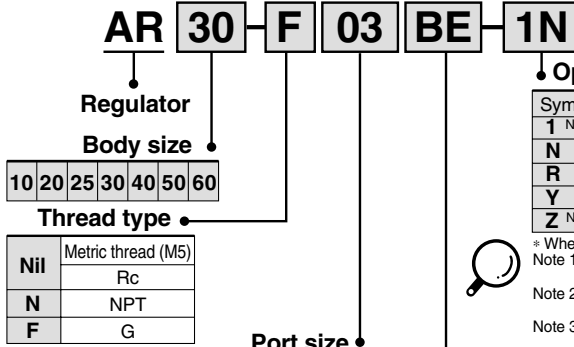

Symbol	Port size	Body size						
		10	20	25	30	40	50	60
M5	M5	●	—	—	—	—	—	—
01	1/8	—	●	—	—	—	—	—
02	1/4	—	●	●	●	●	—	—
03	3/8	—	—	●	●	●	—	—
04	1/2	—	—	—	—	●	—	—
06	3/4	—	—	—	—	●	●	—
10	1	—	—	—	—	—	●	●

Optional specifications

Symbol	Description	Applicable model
1 Note 2)	0.02 to 0.2MPa setting	AR10 to 60
N	Non-relieving	AR10 to 60
R	Flow direction: Right to left	AR10 to 60
Y	Upward handle	AR10 to 60
Z Note 3)	Name plate and pressure gauge in imperial units (PSI, °F)	AR10 to 60

* When more than one specification is required, indicate in ascending alphanumeric order.
 Note 1) This product is for overseas use only according to the new Measurement Law.
 (The SI unit type is provided for use in Japan.)
 Note 2) The only difference from the standard specifications is the adjusting spring for the regulator. It does not restrict the setting of 0.2MPa or more.
 Note 3) For M5 and NPT thread types.

Accessories

Symbol	Description	Applicable model
Nil	—	—
B	With bracket	AR10 to 60
E	With square embedded type pressure gauge (with limit indicator)	AR20 to 60
G	With round pressure gauge (without limit indicator)	AR10
G	With round pressure gauge (with limit indicator)	AR20 to 60
H	With set nut (for panel mount)	AR10 to 40

Note 1) Optional parts are not assembled and are supplied loose at the time of shipment (except for option E).

JIS symbol

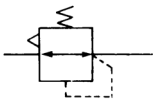

Page 41

Accessory/Optional specification combinations

⊙ : Combination available
 ○ : Varies depending on the model
 ◻ : Combination not available
 △ : Available only with NPT thread

Combination	Symbol	Accessory						Optional specification					Applicable regulator		
		B	E	G	H	1	N	R	Y	Z	AR10	AR20 to 40	AR50 to 60		
Accessories															
With bracket (with set nut)	B	○	○	○	○	○	○	○	○	○	△	○	○	○	
Square embedded type pressure gauge	E	⊙	—	—	—	⊙	⊙	⊙	⊙	⊙	△	—	○	○	
Round pressure gauge	G	⊙	—	—	—	⊙	⊙	⊙	⊙	△	○	○	○	○	
With set nut (for panel mount)	H	—	○	○	—	⊙	⊙	⊙	⊙	△	○	○	—	—	
Optional specifications															
0.02 to 0.2MPa setting	-1	⊙	○	○	○	—	⊙	⊙	⊙	△	○	○	○	○	
Non-relieving type	-N	⊙	○	○	○	⊙	—	⊙	⊙	△	○	○	○	○	
Flow direction: Right to left	-R	⊙	○	○	○	⊙	⊙	—	⊙	△	○	○	○	○	
Upward handle	-Y	⊙	○	○	○	⊙	⊙	⊙	—	△	○	○	○	○	
Name plate and pressure gauge in imperial units (PSI, °F)	-Z	△	△	△	△	△	△	△	△	—	△	△	△	△	

Standard specifications

Model	AR10	AR20	AR25	AR30	AR40	AR40-06	AR50	AR60
Port sizes	M5 x 0.8	1/8, 1/4	1/4, 3/8	1/4, 3/8	1/4, 3/8, 1/2	3/4	3/4, 1	1
Fluid	Air							
Proof pressure	1.5MPa							
Maximum operating pressure	1.0MPa							
Set pressure range	0.05 to 0.7MPa	0.05 to 0.85MPa						
Pressure gauge port size Note 1)	Rc 1/16 Note 2)	Rc, NPT, G 1/8	Rc, NPT, G 1/8	Rc, NPT, G 1/8	Rc, NPT, G 1/4	Rc, NPT, G 1/4	Rc, NPT, G 1/4	Rc, NPT, G 1/4
Relief pressure	Set pressure + 0.05MPa Note 3) [at relief flow rate of 0.1L/min (ANR)]							
Ambient and fluid temperature	-5 to 60°C (with no freezing)							
Construction	Relieving type							
Weight (kg)	0.06	0.26	0.21	0.29	0.44	0.47	1.17	1.22

Note 1) Pressure gauge connection threads are not required for regulator with a square embedded type pressure gauge (AR20 to AR60).
 Note 2) Use a bushing (part no: 131368) when connecting the R 1/8 pressure gauge to the R 1/16 gauge port.
 Note 3) Except for AR10.

Accessory part no.

Applicable model		AR10	AR20	AR25	AR30	AR40	AR40-06	AR50	AR60
Accessory									
Bracket assembly Note 1)		AR10P-270AS	AR20P-270AS	AR25P-270AS	AR30P-270AS	AR40P-270AS	AR40P-270AS	AR50P-270AS Note 5)	AR60P-270AS Note 5)
Set nut		AR10P-260S	AR20P-260S	AR25P-260S	AR30P-260S	AR40P-260S	AR40P-260S	— Note 6)	— Note 6)
Pressure gauge	1MPa	Round	G27-10-R1	G36-10-□01	G36-10-□01	G36-10-□01	G46-10-□02	G46-10-□02	G46-10-□02
		Square embedded type Note 4)	—	GC3-10AS	GC3-10AS	GC3-10AS	GC3-10AS	GC3-10AS	GC3-10AS
	0.2MPa	Round	G27-10-R1 Note 3)	G36-2-□01	G36-2-□01	G36-2-□01	G46-2-□02	G46-2-□02	G46-2-□02
		Square embedded type Note 4)	—	GC3-2AS	GC3-2AS	GC3-2AS	GC3-2AS	GC3-2AS	GC3-2AS

Note 1) Assembly includes a bracket and set nuts.
 Note 2) □ in part numbers for a round pressure gauge indicates a type of connection thread. No indication is necessary for R; however, indicate N for NPT.
 Note 3) For 1.0MPa.
 Note 4) Includes one O-ring and 2 mounting screws.
 Note 5) Assembly includes a bracket and 2 mounting screws.
 Note 6) Contact SMC regarding the set nuts for AR50 and AR60.
 Contact SMC regarding the connection thread NPT and pressure gauge supply for PSI unit specifications.

AR10 to 60

⚠ Specific Product Precautions

Be sure to read before handling.
Refer to pages 75 through 78 for safety instructions and F.R.L. unit precautions.

Mounting & Adjustment

⚠ Warning

1. Set the regulator while verifying the displayed values of the inlet and outlet pressure gauges. Turning the knob excessively can cause damage to the internal parts.
2. The pressure gauge included with regulators for 0.02 to 0.2MPa setting is for up to 0.2MPa use only. Exceeding 0.2MPa of pressure can damage the gauge. Nevertheless, the gauge for the AR10 regulator with 0.02 to 0.2MPa setting is for up to 1.0MPa use.
3. Do not use tools on the pressure regulator knob as this may cause damage. It must be operated manually.

⚠ Caution

1. Be sure to unlock the knob before adjusting the pressure and lock it after setting the pressure.
Failure to follow this procedure can cause damage to the knob and the outlet pressure may fluctuate.
 - Pull the pressure regulator knob to unlock. (You can visually verify this with the "orange mark" that appears in the gap.)
 - Push the pressure regulator knob to lock. When the knob is not easily locked, turn it left and right a little and then push it (when the knob is locked, the "orange mark", i.e., the gap will disappear).



2. A knob cover is available to prevent careless operation of the knob. Refer to Features 1 for details.
3. Contact SMC when using the regulator between a solenoid valve and an actuator.

Flow Characteristics (Representative values)

Condition: Inlet pressure 0.7MPa

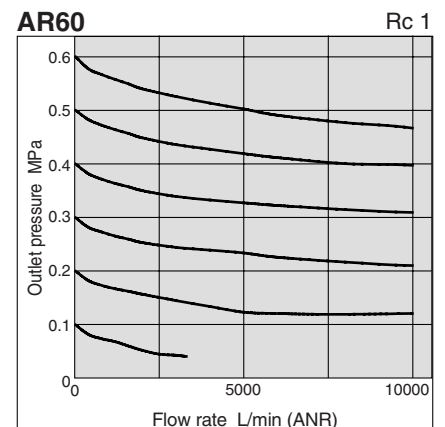
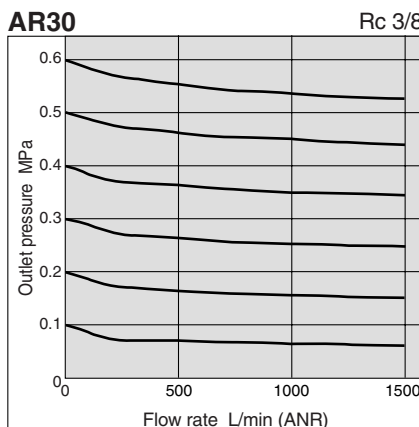
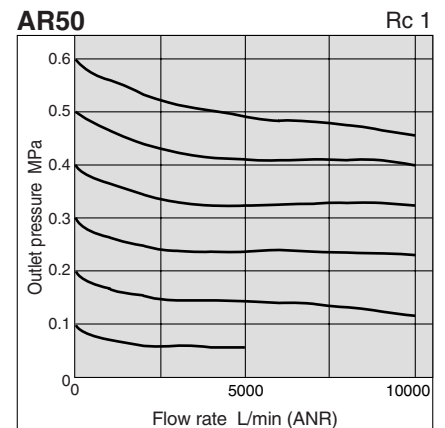
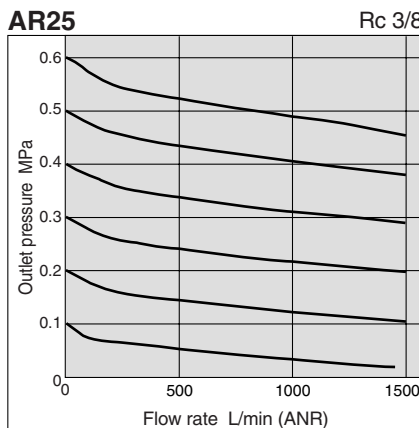
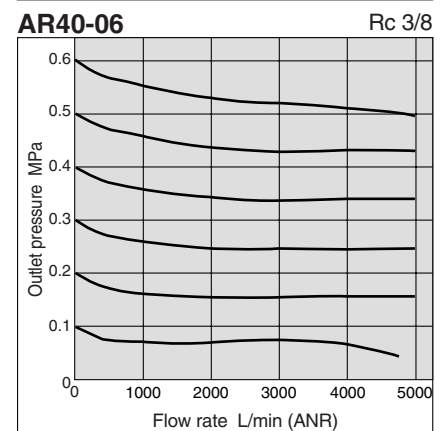
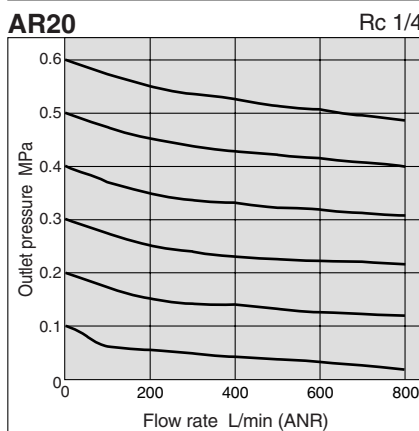
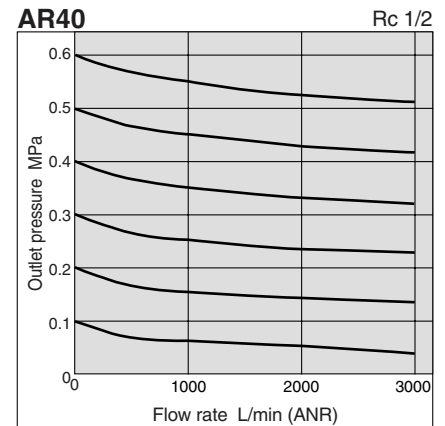
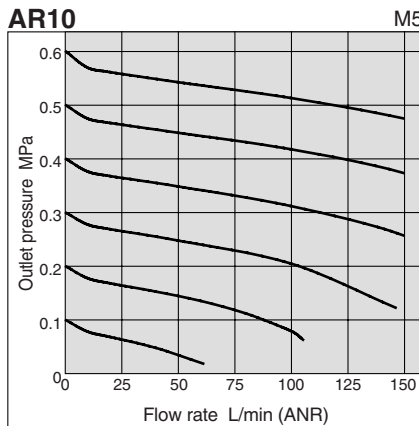

Conditions:
 Inlet pressure 0.7MPa
 Outlet pressure 0.2MPa
 Flow rate 20L/min (ANR)

Pressure Characteristics (Representative values)

AR10

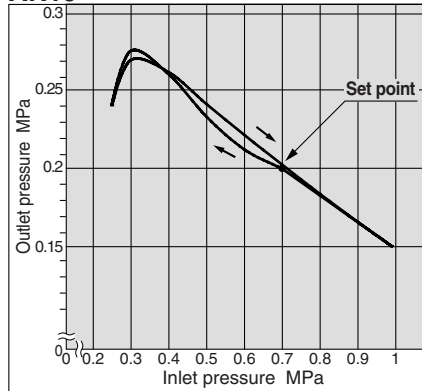

AR40

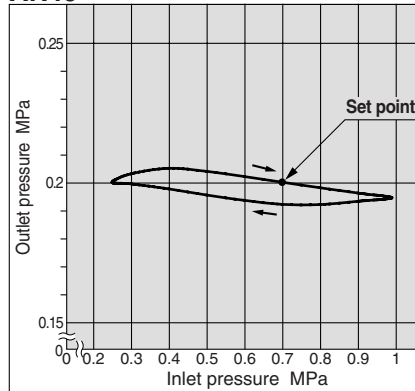

AR20

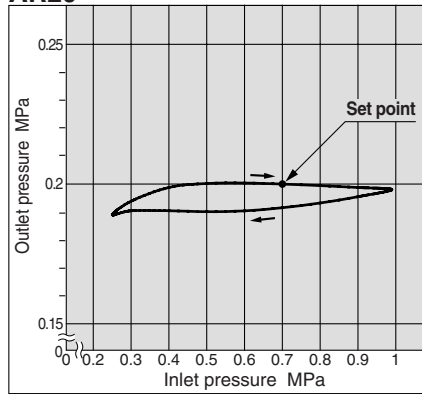

AR40-06

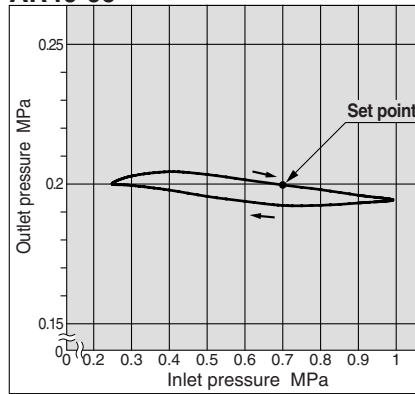

AR25

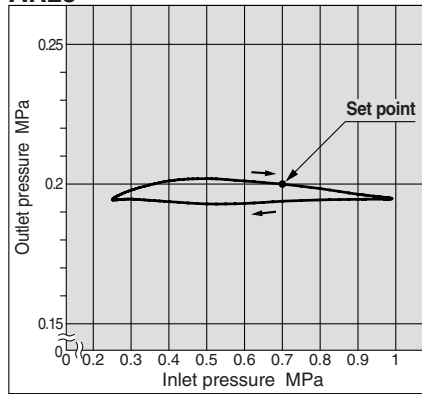

AR50

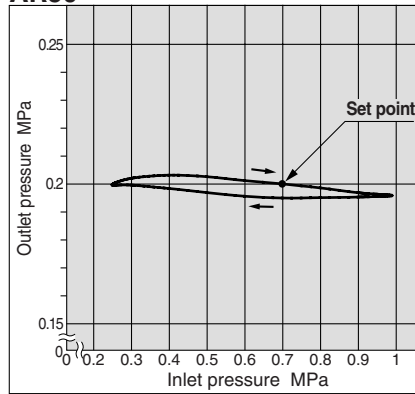

AR30

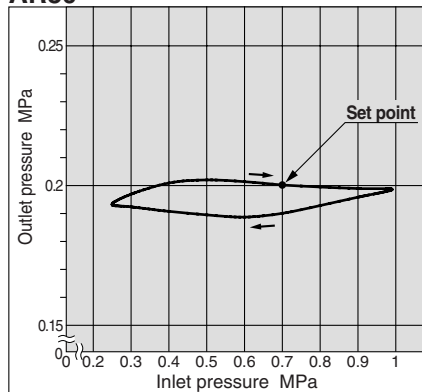

AR60

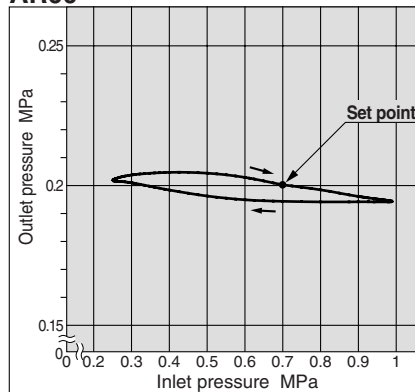

AR10 to 60

Construction

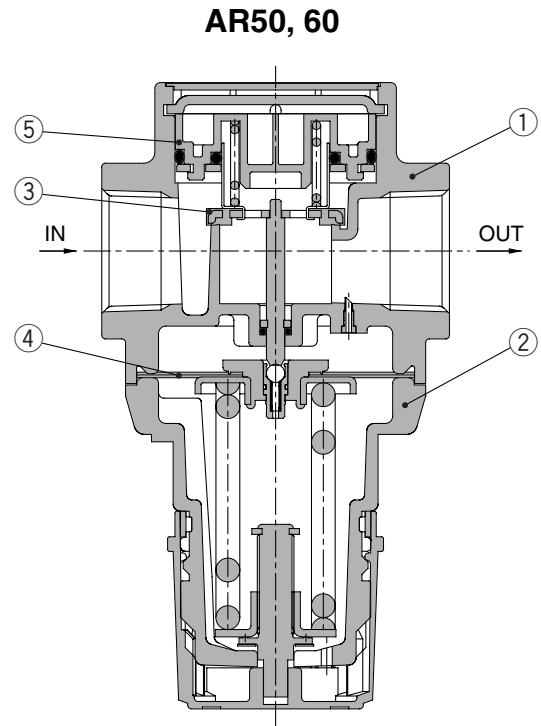
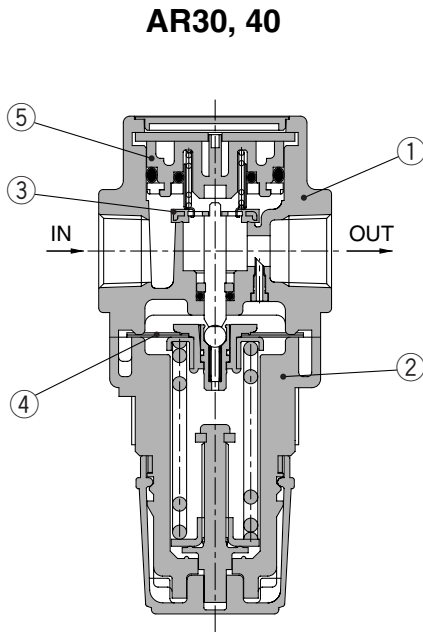
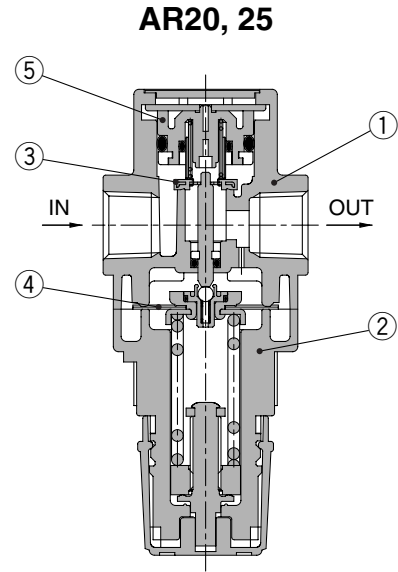
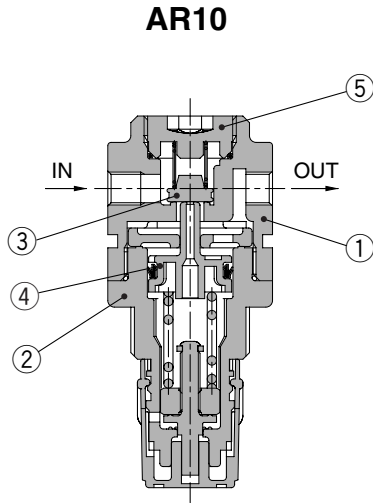

Parts list

No.	Description	Material			Note
		AR10, 20	AR25 to 40 (-60)	AR50, 60	
1	Body	Zinc die-cast	Aluminum die-cast		Platinum silver
2	Bonnet	Polyacetal		Aluminum die-cast	Black

Replacement parts

No.	Description	Materials	Part no.							
			AR10	AR20	AR25	AR30	AR40	AR40-06	AR50	AR60
3	Valve assembly	Stainless steel Brass, HNBR	AR10P-090S	AR20P-090AS	AR25P-090AS	AR30P-090AS	AR40P-090AS	AR40P-090AS	AR50P-090AS	AR60P-090AS
4	Diaphragm assembly	Weatherability NBR	AR10P-150AS (Note)	AR20P-150AS	AR25P-150AS	AR30P-150AS	AR40P-150AS	AR40P-150AS	AR50P-150AS	AR50P-150AS
5	Valve guide assembly	POM	131329	AR20P-050AS	AR25P-050AS	AR30P-050AS	AR40P-050AS	AR40P-050AS	AR50P-050AS	AR60P-050AS



Note) AR10 is a piston and gasket (KSYP-13) type assembly.

Dimensions

AR10 to 40

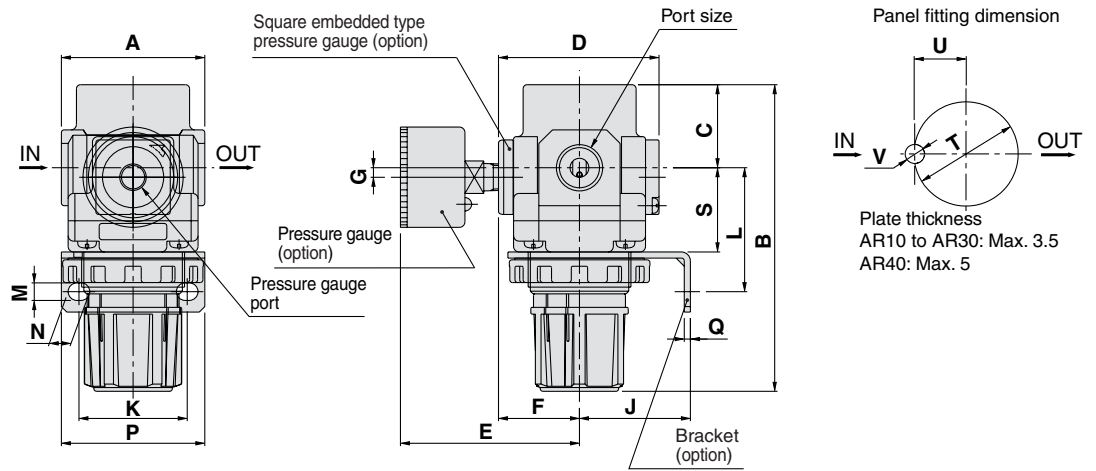

AR50, 60

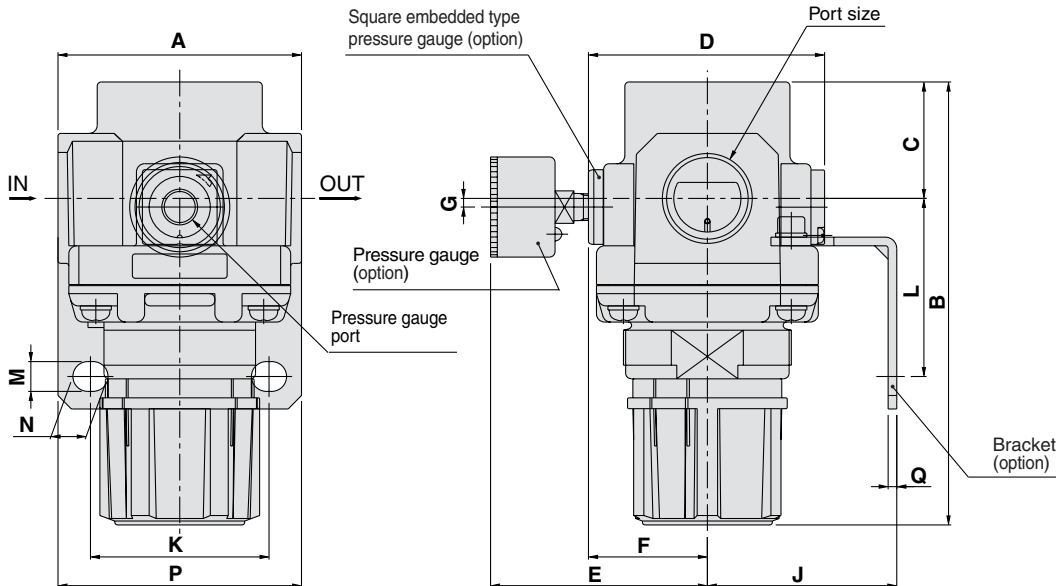

Model	Port sizes	Standard specification				Accessory specification													
						With pressure gauge			Bracket mounting size							Panel mount			
		A	C	B	D	E	F	G	J	K	L	M	N	P	Q	S	T	U	V
AR10	M5 x 0.8	25	11	58	25	26	—	0	25	28	30	4.5	6.5	40	2	18	18.5	—	—
AR20	1/8, 1/4	40	26.5	94	57	65	29.5	2 (Note)	30	34	44	5.4	15.4	55	2.3	25	28.5	14	6
AR25	1/4, 3/8	53	28	101	55	64	28.5	0	30	34	44	5.4	15.4	55	2.3	26	32.5	16	6
AR30	1/4, 3/8	53	31	116	59	66	30.5	3.5	41	40	46	6.5	8	53	2.3	31	38.5	19	7
AR40	1/4, 3/8, 1/2	70	36	128	68	74	35	3.5	50	54	54	8.5	10.5	70	2.3	35.5	42.5	21	7
AR40-06	3/4	75	36	129	68	74	35	3	50	54	56	8.5	10.5	70	2.3	37	42.5	21	7
AR50	3/4, 1	90	43	169	87	84	44.5	3.3	70	66	65.8	11	13	90	3.2	—	—	—	—
AR60	1	95	46	176	87	84	44.5	3.3	70	66	65.8	11	13	90	3.2	—	—	—	—

Note) For AR20 only, the position of the pressure gauge is above the center of the piping.

Regulator AR20 to 60 Made to Order Specifications

Contact SMC for detailed dimensions, specifications, and lead times.



① Special Temperature Environment

Special materials are used in the manufacturing of seals and resin parts to allow them to withstand various temperature conditions in cold or tropical (hot) regions.

Specifications

Part no.	-X430	-X440
Environment	Low temperature	High temperature
Ambient temperature	-30 to 60°C	-5 to 80°C
Fluid temperature	-5 to 60°C (with no freezing)	
Material	Rubber parts	Special NBR / FPM
	Main metal parts	Metal (Die-cast aluminum)

Applicable models

Model	AR25	AR30	AR40	AR40-06	AR50	AR60
Port size	1/4, 3/8	1/4, 3/8	1/4, 3/8, 1/2	3/4	3/4, 1	1

How to Order

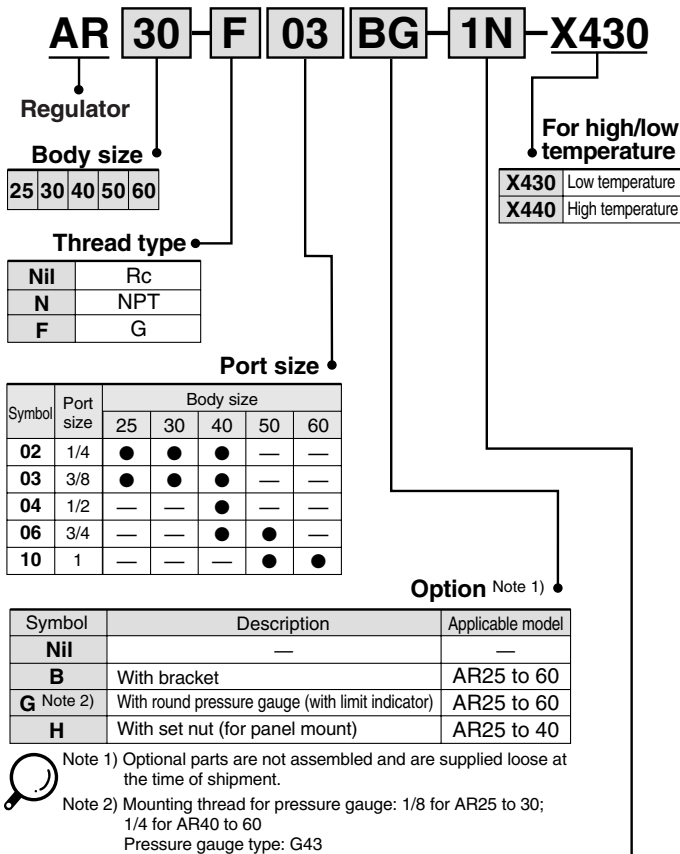

Optional specifications

Symbol	Description	Applicable model
1 Note 3)	0.02 to 0.2MPa setting	AR25 to 60
N	Non-relieving type	AR25 to 60
R	Flow direction: Right to left	AR25 to 60
Y	Upward handle	AR25 to 60
Z Note 4)	Name plate and pressure gauge in imperial units (PSI, °F)	AR25 to 60

* When more than one specification is required, indicate in ascending alphanumeric order.

Note 3) The only difference from the standard specifications is the adjusting spring for the regulator. It does not restrict the setting of 0.2MPa or more.

Note 4) For thread type NPT. This product is for overseas use only according to the new Measurement Law. (The SI unit type is provided for use in Japan.)

Note 5) Consult SMC for detailed dimensions and available attachments and options.

Note 6) Comes with T type handle.

② High Pressure

Strong materials are used in the manufacturing of air filters intended for high pressure operation. Also construction modification allows a wider regulating pressure range.

Specifications

Part no.	-X425
Proof pressure	3.0MPa
Maximum operating pressure	2.0MPa
Set pressure range	0.1 to 1.6MPa
Ambient and fluid temperature	-5 to 60°C (with no freezing)



Applicable models

Model	AR20	AR25	AR30	AR40	AR40-06	AR50	AR60
Port size	1/8, 1/4	1/4, 3/8	1/4, 3/8	1/4, 3/8, 1/2	3/4	3/4, 1	1

How to Order

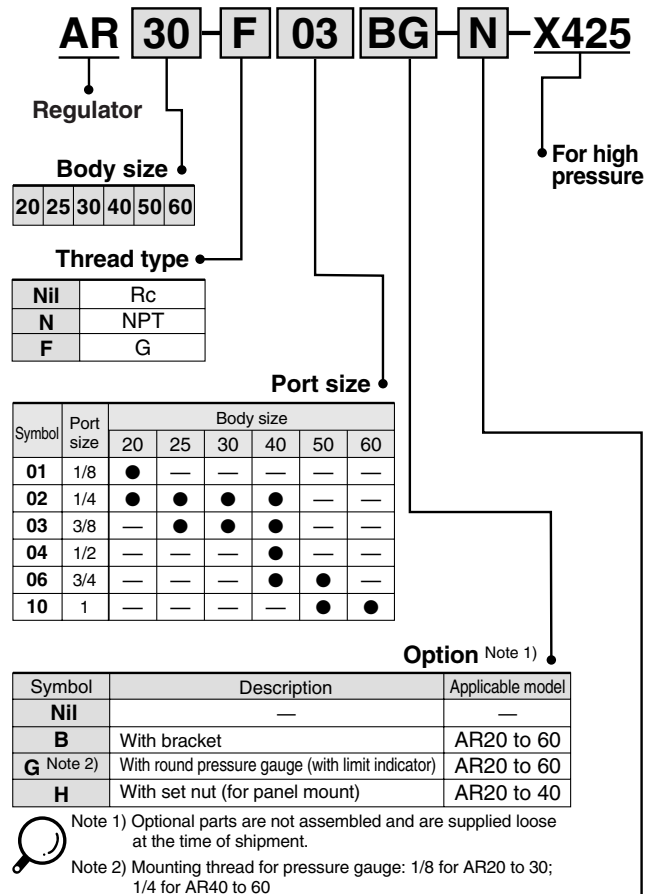

Optional specifications

Symbol	Description	Applicable model
N	Non-relieving	AR20 to 60
R	Flow direction: Right to left	AR20 to 60
Y	Upward handle	AR20 to 60
Z Note 3)	Name plate and pressure gauge in imperial units (PSI, °F)	AR20 to 60

* When more than one specification is required, indicate in ascending alphanumeric order.

Note 3) For thread type NPT. This product is for overseas use only according to the new Measurement Law. (The SI unit type is provided for use in Japan.)

Regulator AR20(K) to AR60(K) Made to Order Specifications

Contact SMC for detailed dimensions, specifications, and lead times.



③ With Digital Pressure Switch

Digital pressure switch (ISE30-□□-□□-□L) is supplied loose for mounting on pressure gauge connection port.

Specifications

Part number suffix		-X465
Pressure switch	Model	ISE30-□□-□□-□L
	Set pressure range (MPa)	-0.1 to 1
	Set and display resolution (MPa)	0.001
	Power supply voltage	12 to 24 VDC ± 10%, Ripple (p-p) 10% or less (with power supply polarity protection)
	Power consumption	45 mA or less (70 mA or less for current output)

* Pressure gauge port size: 1/8

Applicable models

Model	AR20(K)	AR25(K)	AR30(K)	AR40(K)	AR40(K)-06	AR50(K)	AR60(K)
Port sizes	1/8, 1/4	1/4, 3/8	1/4, 3/8	1/4, 3/8, 1/2	3/4	3/4, 1	1



How to Order

AR 30 K F 03 B 1N X465 A

Regulator

Body size

20	25	30	40	50	60
----	----	----	----	----	----

Back flow mechanism

Nil	Without back flow mechanism
K	With back flow mechanism

Thread type

Nil	Rc
N	NPT
F	G

Port size

Symbol	Port size	Body size					
		20	25	30	40	50	60
01	1/8	●	—	—	—	—	—
02	1/4	●	●	●	●	—	—
03	3/8	—	●	●	●	—	—
04	1/2	—	—	—	●	—	—
06	3/4	—	—	—	●	●	—
10	1	—	—	—	—	●	●

Switch specifications

Symbol	Output specification
A	NPN output
B	PNP output
C	1 to 5V output
D	4 to 20mA output

With digital pressure switch (Series ISE30) Note 4)

Note 4) Digital pressure switch is not assembled and are supplied loose at the time of shipment.

Note 5) Consult SMC for detailed dimensions and available attachments and options.

Note 6) Refer to SMC catalog CATES100-42 for detailed specifications and instructions of digital pressure switch.

Optional specifications

Symbol	Description	Applicable model
1 Note 2)	0.02 to 0.2MPa setting	AR20(K) to 60(K)
N	Non-relieving type	AR20(K) to 60(K)
R	Flow direction: Right to left	AR20(K) to 60(K)
Y	Upward handle	AR20(K) to 60(K)
Z Note 3)	Name plate and pressure gauge in imperial units (PSI, °F)	AR20(K) to 60(K)

* When more than one specification is required, indicate in ascending alphanumeric order.

Note 2) The only difference from the standard specifications is the adjusting spring for the regulator. It does not restrict the setting of 0.2MPa or more.

Note 3) For thread type NPT. This product is for overseas use only according to the new Measurement Law. (The SI unit type is provided for use in Japan.)

Option Note 1)

Symbol	Description	Applicable model
Nil	—	—
B	With bracket	AR20(K) to 60(K)
H	With set nut (for panel mount)	AR20(K) to 40(K)

Note 1) Optional parts are not assembled and are supplied loose at the time of shipment.

Regulator: Modular Type with Back flow Mechanism

AR20K to 60K

How to Order

Regulator with a built-in mechanism that ensures a quick release of the outlet air pressure (built-in check valve with back flow mechanism).



AR20K

AR40K

Example 1)
When the pressure in the rear and the front of the cylinder differs:

Circuit diagram

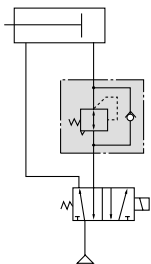

Example 2)
When the air supply is cut off and releasing the inlet pressure to the atmosphere, the residual pressure release of the outlet side can be ensured for a safety purpose.

Circuit diagram

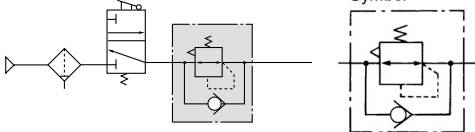

AR30 K — F 03 BE — 1N

Regulator

Body size

20	25	30	40	50	60
----	----	----	----	----	----

With back flow mechanism

Note) AR10 comes with a back flow mechanism as a standard feature.
If the set pressure is below 0.15MPa, back flow may not occur. When a backflow mechanism is required with a set pressure of less than 0.15MPa, contact SMC.

Thread type

Nil	Rc
N	NPT
F	G

Port size

Symbol	Port size	Body size					
		20	25	30	40	50	60
01	1/8	●	—	—	—	—	—
02	1/4	●	●	●	—	—	—
03	3/8	—	●	●	●	—	—
04	1/2	—	—	—	●	—	—
06	3/4	—	—	—	●	●	—
10	1	—	—	—	—	●	●

Optional specifications

Symbol	Description	Applicable model
1 Note 2)	0.02 to 0.2MPa setting	AR20K to 60K
N	Non-relieving	AR20K to 60K
R	Flow direction: Right to left	AR20K to 60K
Y	Upward handle	AR20K to 60K
Z Note 3)	Name plate and pressure gauge in imperial units (PSI, °F)	AR20K to 60K

* When more than one specification is required, indicate in alphanumeric order.

Note 2) The only difference from the standard specifications is the adjusting spring for the regulator. It does not restrict the setting of 0.2MPa or more.

Note 3) For NPT thread type.
This product is for overseas use only according to the new Measurement Law. (The SI unit type is provided for use in Japan.)

Accessories Note 1)

Symbol	Description	Applicable model
Nil	—	—
B	With bracket	AR20K to 60K
E	With square embedded type pressure gauge (with limit indicator)	AR20K to 60K
G	With round pressure gauge (with limit indicator)	AR20K to 60K
H	With set nut (for panel mount)	AR20K to 40K

Note 1) Optional parts are not assembled and are supplied loose at the time of shipment (except for option E).

Standard specifications

Model	AR20K	AR25K	AR30K	AR40K	AR40K-06	AR50K	AR60K
Port sizes	1/8, 1/4	1/4, 3/8	1/4, 3/8	1/4, 3/8, 1/2	3/4	3/4, 1	1
Fluid	Air						
Proof pressure	1.5MPa						
Maximum operating pressure	1.0MPa						
Set pressure range Note 1)	0.05 to 0.85MPa						
Pressure gauge port size Note 2)	Rc, NPT, G 1/8	Rc, NPT, G 1/8	Rc, NPT, G 1/8	Rc, NPT, G 1/4	Rc, NPT, G 1/4	Rc, NPT, G 1/4	Rc, NPT, G 1/4
Relief pressure	Set pressure + 0.05MPa [at relief flow rate of 0.1L/min (ANR)]						
Ambient and fluid temperature	-5° to 60°C (with no freezing)						
Construction	Relieving type						
Weight (kg)	0.26	0.21	0.30	0.45	0.48	1.17	1.22

* AR10 comes with a back flow mechanism as a standard feature.

Note 1) Set the inlet pressure 0.05MPa or higher than the set pressure.

Note 2) Pressure gauge connection threads are not required for regulators with a square embedded type pressure gauge (AR20K to AR60K).

Accessory part no.

Accessory	Applicable model	AR20K	AR25K	AR30K	AR40K	AR40K-06	AR50K	AR60K	
Bracket assembly Note 1)		AR20P-270AS	AR25P-270AS	AR30P-270AS	AR40P-270AS	AR40P-270AS	AR50P-270AS Note 3)	AR50P-270AS Note 3)	
Set nut		AR20P-260S	AR25P-260S	AR30P-260S	AR40P-260S	AR40P-260S	— Note 5)	— Note 5)	
Pressure gauge Note 2)	1.0MPa	Round	G36-10-□01	G36-10-□01	G36-10-□01	G46-10-□02	G46-10-□02	G46-10-□02	
		Square embedded type Note 4)	GC3-10AS	GC3-10AS	GC3-10AS	GC3-10AS	GC3-10AS	GC3-10AS	GC3-10AS
	0.2MPa	Round	G36-2-□01	G36-2-□01	G36-2-□01	G46-2-□02	G46-2-□02	G46-2-□02	G46-2-□02
		Square embedded type Note 4)	GC3-2AS	GC3-2AS	GC3-2AS	GC3-2AS	GC3-2AS	GC3-2AS	GC3-2AS

Note 1) Assembly includes a bracket and set nuts.

Note 2) □ in part numbers for a round pressure gauge indicates a type of connection thread. No indication is necessary for R; however, indicate N for NPT.

Contact SMC regarding the connection thread NPT and pressure gauge supply for PSI unit specifications.

Note 3) Assembly includes a bracket and 2 mounting screws.

Note 4) Includes one O-ring and 2 mounting screws.

Note 5) Contact SMC regarding the set nut for AR50K and 60K.

Operating Principle

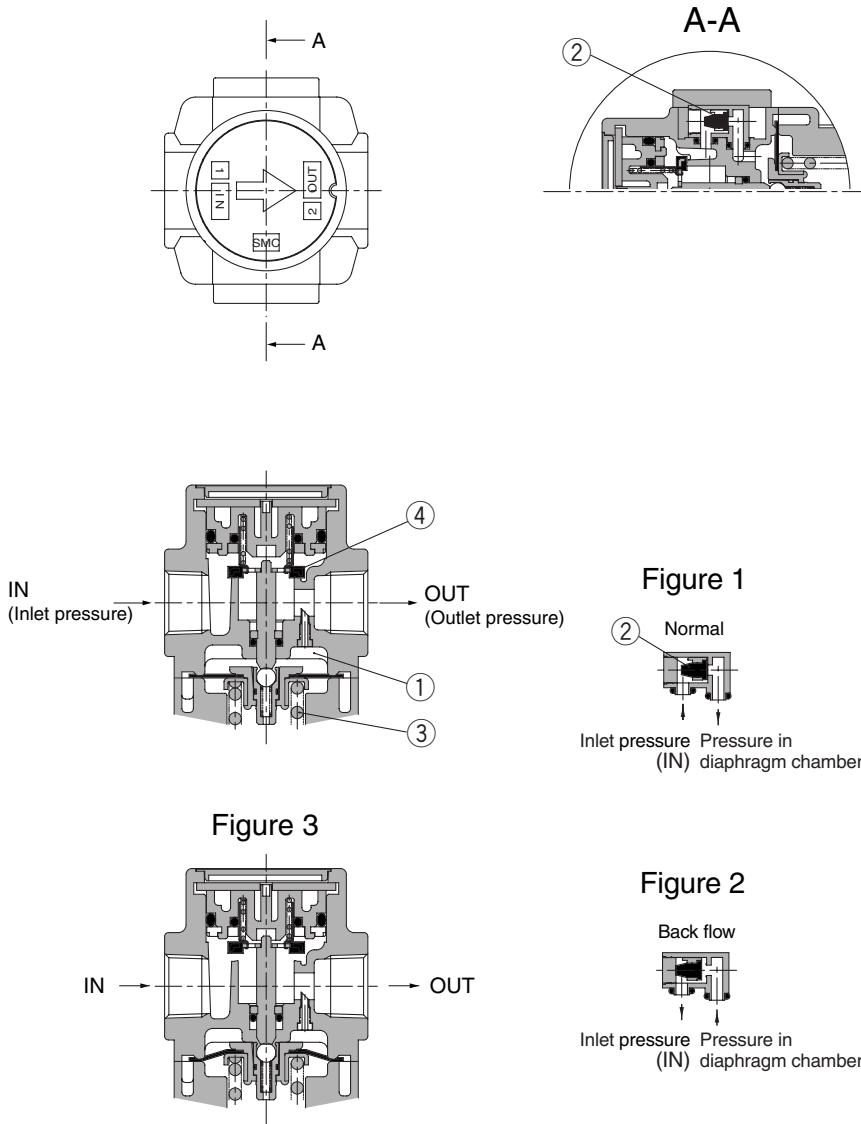

When the inlet pressure (P_1) is higher than the regulating pressure, the check valve ② closes and operates as a normal regulator (Figure 1).
 When the inlet pressure (P_1) is shut off and released, the check valve ② opens and the pressure in the diaphragm chamber ① is released into the inlet side (Figure 2).
 This lowers the pressure in the diaphragm chamber ① and the force generated by the pressure regulator spring ③ lifts the diaphragm. Valve ④ opens through the stem, and the outlet pressure is released to the inlet side (Figure 3).

⚠ Specific Product Precautions

Be sure to read before handling.
 Refer to pages 75 through 78 for safety instructions and F.R.L. unit precautions.

Mounting & Adjustment

⚠ Warning

1. Set the regulator while verifying the displayed values of the inlet and outlet pressure gauges. Turning the regulator knob excessively can cause damage to the internal parts.
2. Do not use tools on the pressure regulator knob as this may cause damage. It must be operated manually.

⚠ Caution

1. Be sure to unlock the knob before adjusting the pressure and lock it after setting the pressure.
 Failure to follow this procedure can cause damage to the knob and the outlet pressure may fluctuate.



- Pull the pressure regulator knob to unlock. (You can visually verify this with the "orange mark" that appears in the gap.)
 - Push the pressure regulator knob to lock. When the knob is not easily locked, turn it left and right a little and then push it (when the knob is locked, the "orange mark", i.e., the gap will disappear).
2. A knob cover is available to prevent careless operation of the knob. Refer to Features 1 for details.

Maintenance

⚠ Warning

1. When using the regulator between a solenoid valve and an actuator, check the pressure gauge periodically.
 Sudden pressure fluctuations may shorten the durability of the pressure gauge. A digital pressure gauge is recommended for such situation or as deemed necessary.

AR20K to 60K

Flow Characteristics (Representative values)

Condition: Inlet pressure 0.7MPa

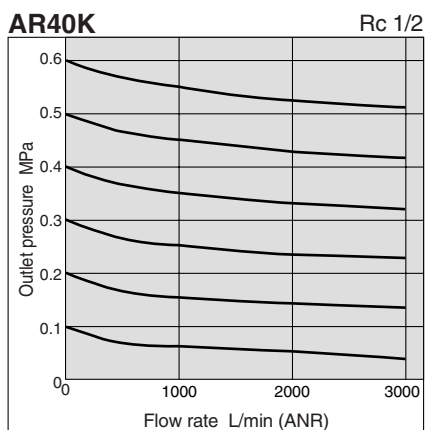
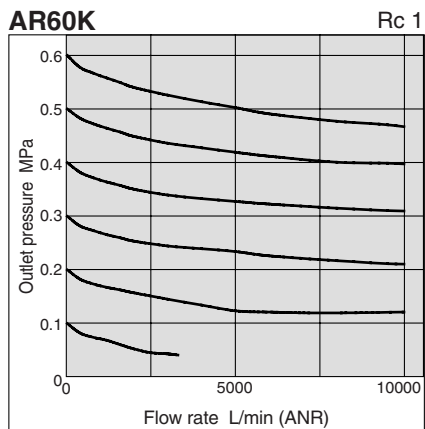
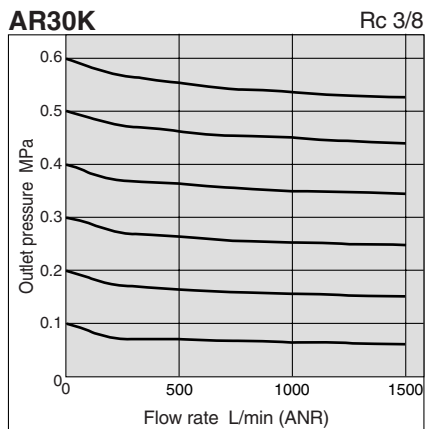
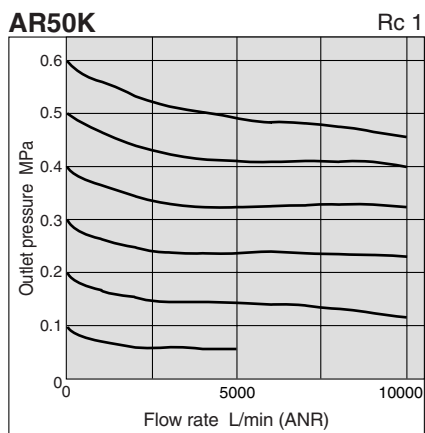
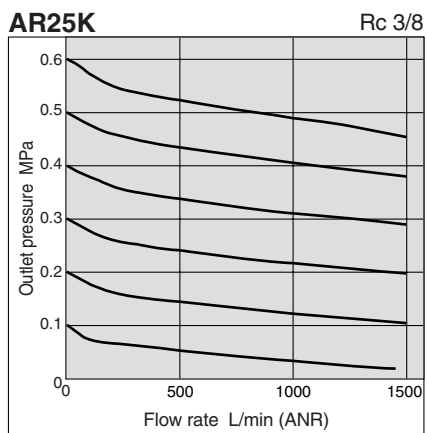
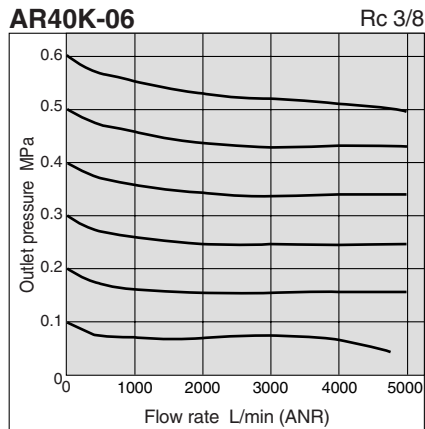
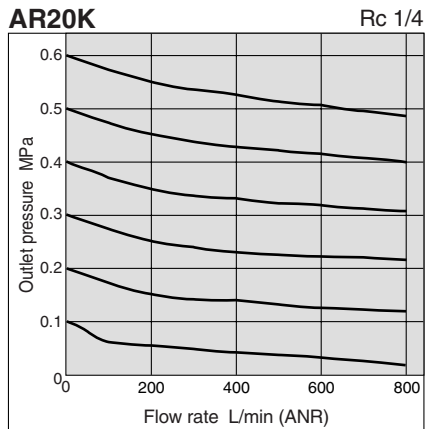

Conditions:
 Inlet pressure 0.7MPa
 Outlet pressure 0.2MPa
 Flow rate 20L/min (ANR)

Pressure Characteristics (Representative values)

AR20K

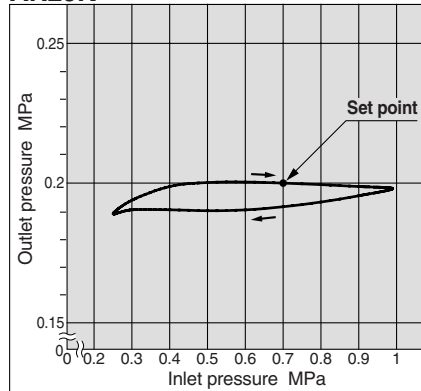

AR40K-06

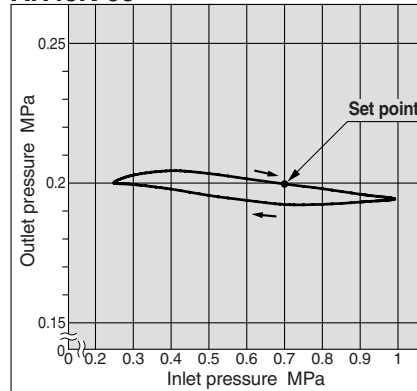

AR25K

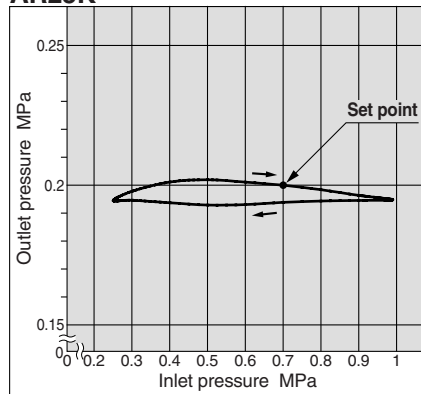

AR50K

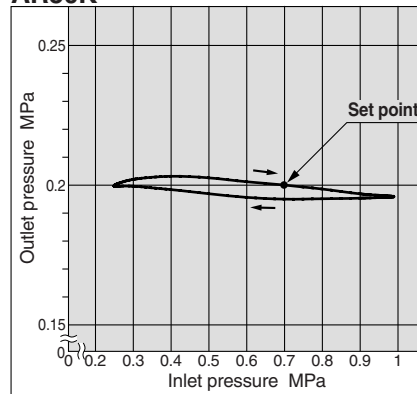

AR30K

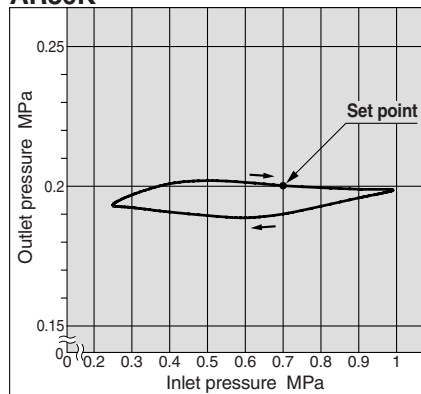

AR60K

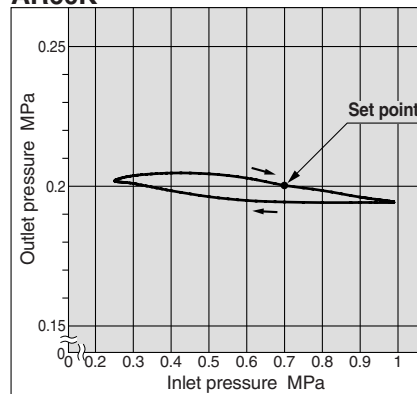

AR40K

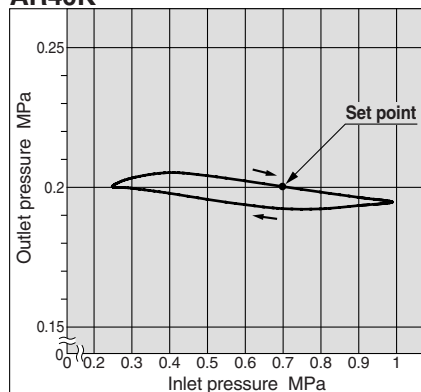

AR20K to 60K

Construction

AR20K to 60K

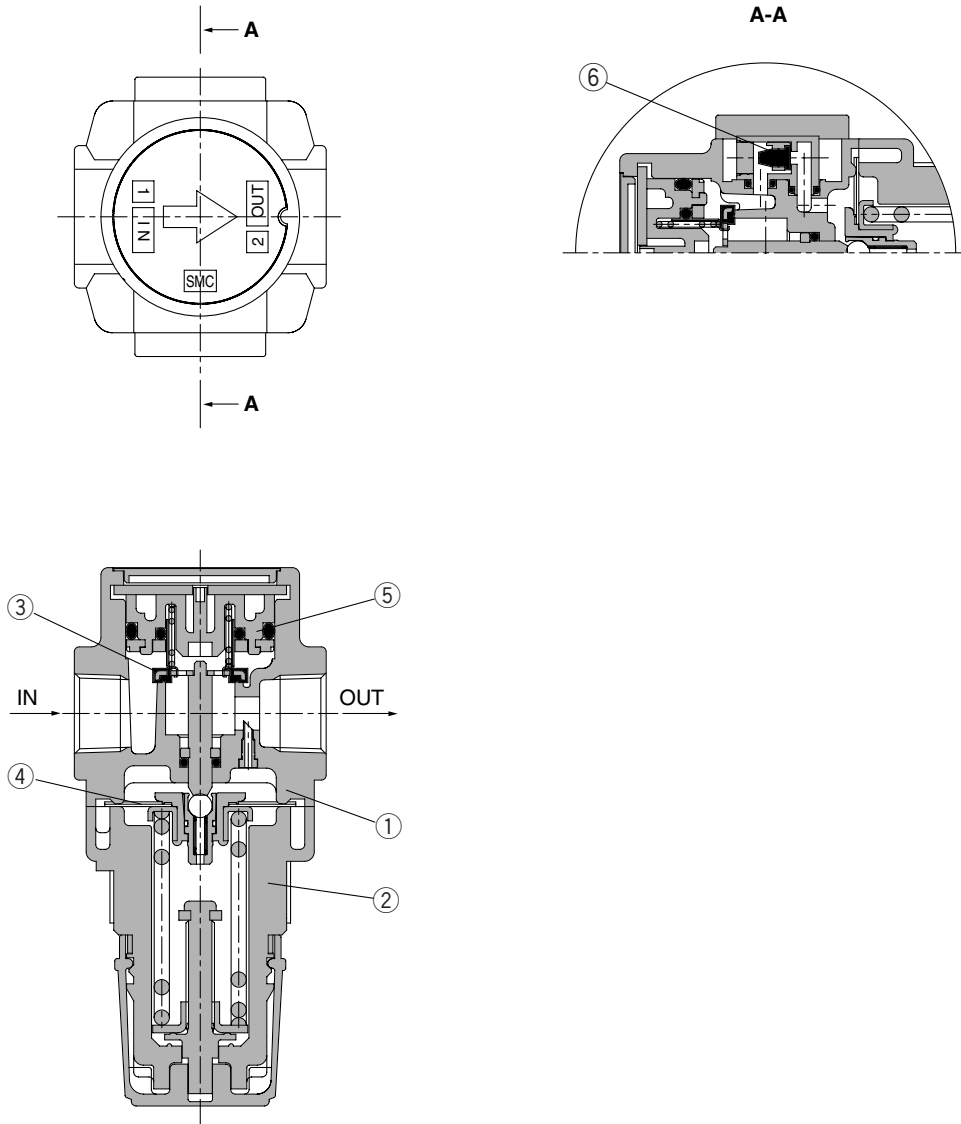

Parts list

No.	Description	Material			Note
		AR20K	AR25K to 40K (-06)	AR50K, 60K	
1	Body	Zinc die-cast	Aluminum die-cast		Platinum silver
2	Bonnet	Polyacetal		Aluminum die-cast	Black

Replacement parts

No.	Description	Material	Part no.						
			AR20K	AR25K	AR30K	AR40K	AR40K-06	AR50K	AR60K
3	Valve assembly	Stainless steel Brass, HNBR	AR20P-090AS	AR25P-090AS	AR30P-090AS	AR40P-090AS	AR40P-090AS	AR50P-090AS	AR60P-090AS
4	Diaphragm assembly	Weatherability NBR	AR20P-150AS	AR25P-150AS	AR30P-150AS	AR40P-150AS	AR40P-150AS	AR50P-150AS	AR60P-150AS
5	Valve guide assembly	POM	AR20P-050AS	AR25P-050AS	AR30P-050AS	AR40P-050AS	AR40P-050AS	AR50P-050AS	AR60P-050AS
6	Check valve assembly ^{Note)}	—	AR20KP-020AS	AR20KP-020AS	AR20KP-020AS	AR20KP-020AS	AR20KP-020AS	AR20KP-020AS	AR20KP-020AS

 Note) Check valve construction includes a check valve cover and 2 screws.

Regulator with Back Flow Mechanism **AR20K to 60K**

Dimensions

AR20K to 40K

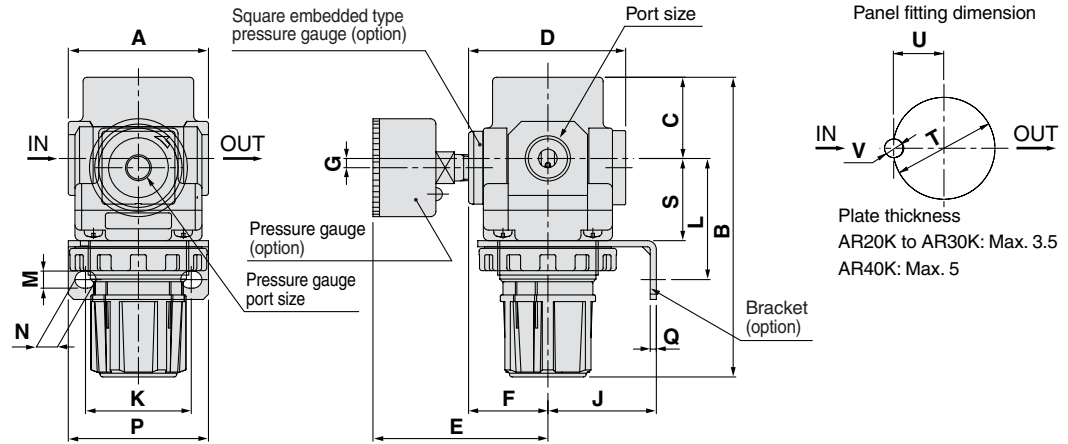

AR50K, 60K

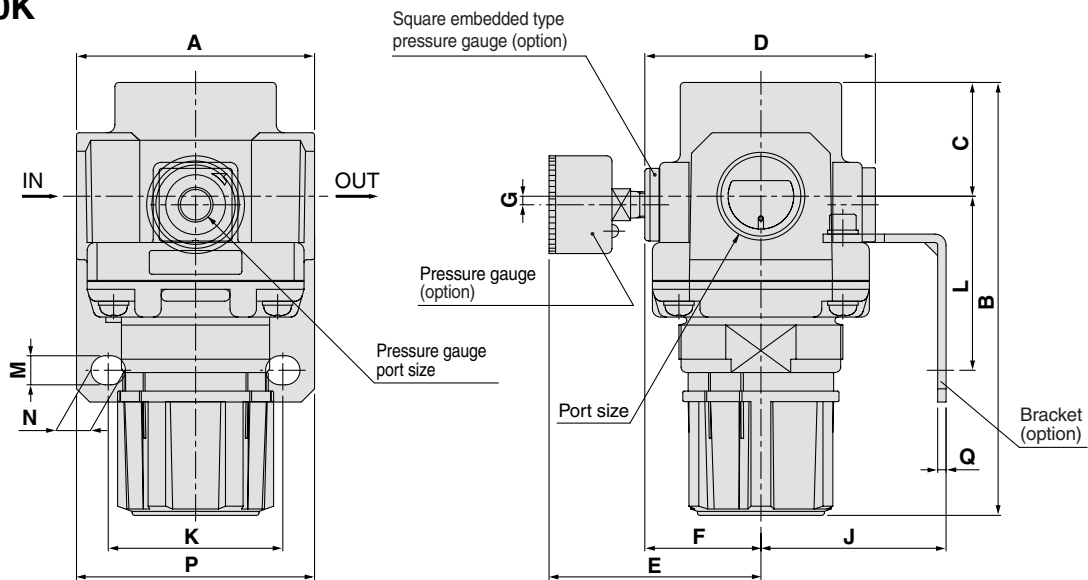

Model	Port size	Standard specification				Accessory specification													
						With pressure gauge			Bracket mounting size							Panel mount			
		A	B	C	D	E	F	G	J	K	L	M	N	P	Q	S	T	U	V
AR20K	1/8, 1/4	40	94	26.5	57	65	29.5	2 ^{Note)}	30	34	44	5.4	15.4	55	2.3	25	28.5	14	6
AR25K	1/4, 3/8	53	101	28	55	64	28.5	0	30	34	44	5.4	15.4	55	2.3	26	32.5	16	6
AR30K	1/4, 3/8	53	116	31	59	66	30.5	3.5	41	40	46	6.5	8	53	2.3	31	38.5	19	7
AR40K	1/4, 3/8, 1/2	70	128	36	68	74	35	3.5	50	54	54	8.5	10.5	70	2.3	35.5	42.5	21	7
AR40K-06	3/4	75	129	36	68	74	35	3	50	54	56	8.5	10.5	70	2.3	37	42.5	21	7
AR50K	3/4, 1	90	169	43	87	84	44.5	3.3	70	66	65.8	11	13	90	3.2	—	—	—	—
AR60K	1	95	176	46	87	84	44.5	3.3	70	66	65.8	11	13	90	3.2	—	—	—	—

Note) For AR20K only, the position of the pressure gauge is above the center of the piping.

Modular Type Lubricator *Series AL*

Lubricator Series AL



Pages 50 through 54

Model	Port size	Accessory
AL10	M5 x 0.8	Bracket
AL20	1/8, 1/4	
AL30	1/4, 3/8	
AL40	1/4, 3/8, 1/2	
AL40-06	3/4	
AL50	3/4, 1	
AL60	1	

Lubricator

AL10 to 60

How to Order

AL 30 - F 03 B - 2R

Lubricator

Body size

10 20 30 40 50 60

Thread type

Nil	Metric thread (M5)
	Rc
N	NPT
F	G

Port size

Symbol	Port size	Body size					
		10	20	30	40	50	60
M5	M5	●	—	—	—	—	—
01	1/8	—	●	—	—	—	—
02	1/4	—	●	●	—	—	—
03	3/8	—	—	●	●	—	—
04	1/2	—	—	—	—	—	—
06	3/4	—	—	—	—	●	—
10	1	—	—	—	—	●	●

Optional specifications

Symbol	Description	Applicable model
1	1000cm ³ tank	AL30 to 60
10	1000cm ³ tank with level switch (lowest limit ON)	AL30 to 60
11	1000cm ³ tank with level switch (lowest limit OFF)	AL30 to 60
2	Metal bowl	AL10 to 60
3	With drain cock	AL10 to 60
6	Nylon bowl (including sight dome)	AL10 to 60
8	Metal bowl with level gauge	AL30 to 60
C	With bowl guard	AL20
R	Flow direction: Right to left	AL10 to 60
3W	Drain cock with barb fitting: ø6 x ø4 nylon tubing	AL30 to 60
Z ^{Note 2)}	Name plate and caution plate for bowl in imperial units (PSI, °F)	AL10 to 60

Accessory * When more than one specification is required, indicate in alphanumeric order.

Symbol	Description	Applicable model
Nil	—	—
B ^{Note 1)}	With bracket	AL20 to AL 60

Note 2) For M5 and NPT thread types. This product is for overseas use only according to the new Measurement Law. (The SI unit type is provided for use in Japan.)

Note 1) Bracket is not assembled and is supplied loose at the time of shipment.

◎ : Combination available

◻ : Combination not available

○ : Varies depending on the model

△ : Available only with NPT thread

Accessory/Optional specification combinations

Accessory/Optional specifications	Combination	Symbol	Accessory	Optional specification											Applicable lubricator				
				B	1	10	11	2	3	6	8	C	R	3W	Z	AL10	AL20	AL30 to 60	
Accessory	With bracket	B		○	○	○	○	◎	◎	◎	○	○	◎	○	△		◎	◎	
Optional specifications	1000cm ³ tank	-1	◎															◎	
	1000cm ³ tank with level switch (lowest limit ON)	-10	◎																◎
	1000cm ³ tank with level switch (lowest limit OFF)	-11	◎																◎
	Metal bowl	-2	◎						◎										◎
	With drain cock	-3	◎					◎		◎	○	○	◎	○	△	◎	◎	◎	◎
	Nylon bowl (including sight dome)	-6	◎							◎				◎	○	△	◎	◎	◎
	Metal bowl with level gauge	-8	◎								◎								◎
	With bowl guard	-C	◎								◎	◎							◎
	Flow direction: Right to left	-R	◎	◎	◎	◎	◎	◎	◎	◎	◎	◎	◎	◎	◎	△	◎	◎	◎
	Drain cock with barb fitting: ø6 x ø4 nylon tubing	-3W	◎	◎	◎	◎	◎	◎	◎	◎	◎	◎	◎	◎	◎	△	◎	◎	◎
	Name plate and caution plate for bowl in imperial units (PSI, °F)	-Z	△	△	△	△	△	△	△	△	△	△	△	△	△	△	△	△	△

Note) -1, -10, -11 are for a metal bowl with level gauge that comes with drain cock.



AL20



AL40

JIS symbol



Standard specifications

Model	AL10	AL20	AL30	AL40	AL40-06	AL50	AL60
Port sizes	M5 x 0.8	1/8, 1/4	1/4, 3/8	1/4, 3/8, 1/2	3/4	3/4, 1	1
Fluid	Air						
Proof pressure	1.5MPa						
Maximum operating pressure	1.0MPa						
Minimum dripping flow rate [L/min (ANR)] ^{Note 1)}	4	15	1/4: 30 3/8: 40	1/4: 30 3/8: 40 1/2: 50	50	190	220
Oil capacity (cm ³)	7	25	55	135	135	135	135
Recommended lubricant	Class 1 turbine oil (ISO VG32)						
Ambient and fluid temperature	-5 to 60°C (with no freezing)						
Bowl material	Polycarbonate						
Bowl guard	—	Option	Standard				
Weight (kg)	0.07	0.20	0.24	0.47	0.52	1.06	1.13

Notes 1) • The flow rate is 5 drips/min under the following conditions: Inlet pressure of 0.5MPa; Class 1 turbine oil (ISO VG32); Temperature at 20°C; Oil adjustment valve fully open.

• Use air consumption flow rate for minimum dripping flow rate.

Accessory part no.

Accessory	Applicable model	AL10	AL20	AL30	AL40	AL40-06	AL50	AL60
Bracket assembly ^{Note)}		—	AF20P-050AS	AF30P-050AS	AF40P-050AS	AF40P-070AS	AF50P-050AS	AF50P-050AS

* The part number for Bracket assembly for 1000cm³ is AF50P-050AS (applicable to AL30 to AL60).

Note) Assembly includes a bracket and 2 mounting screws.

AL10 to 60

Flow Characteristics (Representative values)

Condition: Inlet pressure 0.7MPa

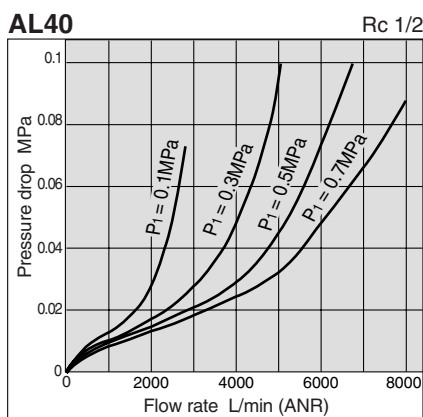
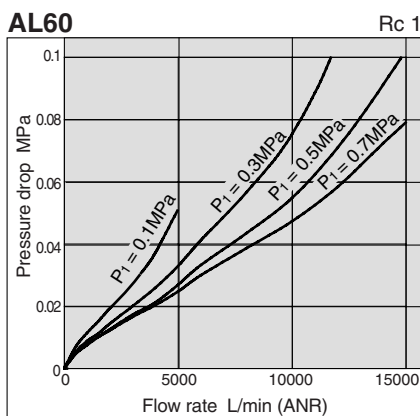
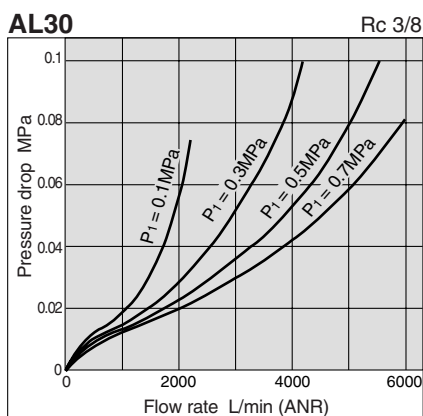
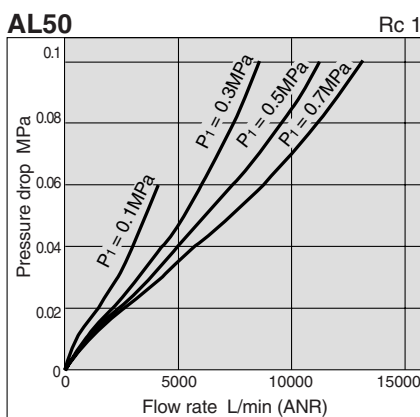
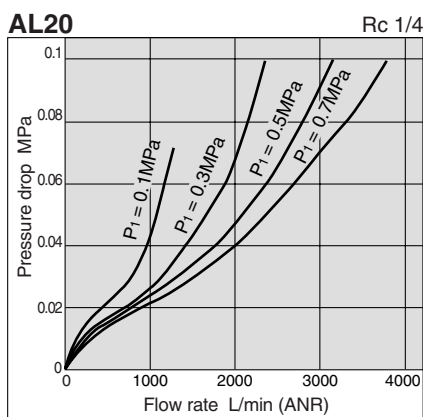
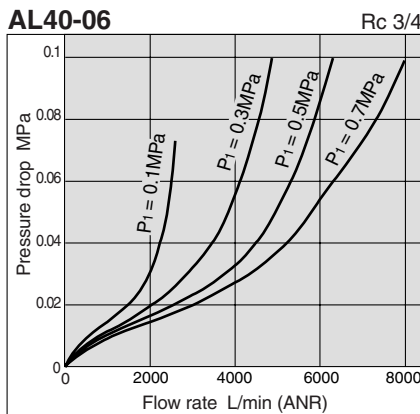
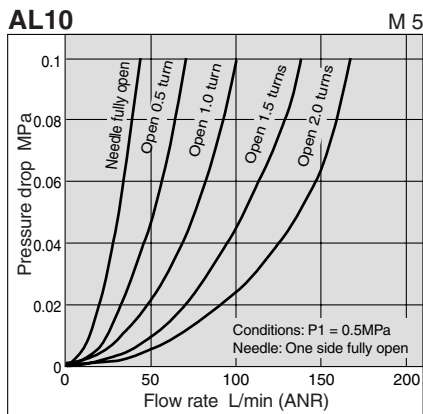

Operating Principle: AL10 Type

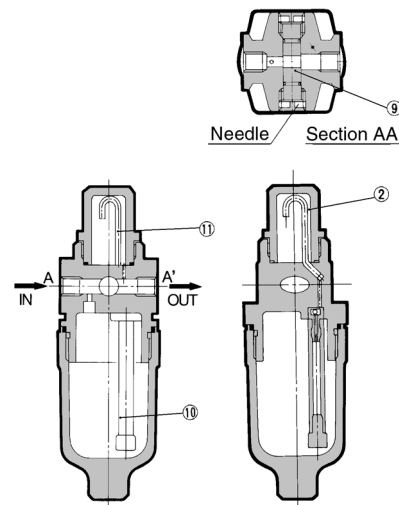

A portion of the air introduced from the IN side pressurizes the lubricant inside the bowl. The remainder of the air passes through the needles (9), and flows to the OUT side. The pressure differential between the inside of the bowl and the inside of the sight dome (2), causes the lubricant inside the bowl into the oil passage (10). The lubricant drips from the dripping tube (11), and lubricate the OUT side. The amount of lubricant is adjusted by the needle (9), on the front face. Turning the needle clockwise increases the amount of the lubricant, and turning it counterclockwise until fully opened shuts off the lubricant. The needle on the side that is not used should be left fully opened.

Note) The operating principle for AL20 to 60 types is different from that of AL10 type.

⚠ Specific Product Precautions

Be sure to read before handling. Refer to pages 75 through 78 for safety instructions and F.R.L. unit precautions.

Selection

⚠ Warning

1. Do not introduce air from the outlet side as this can damage the damper.

⚠ Caution

1. Use a check valve (series AKM) to prevent back flow of the lubricant when redirecting the air flow before the lubricator.

Maintenance

⚠ Warning

1. For AL10 type, replenish the lubricant after releasing the inlet pressure. Lubrication cannot take place under a pressurized condition.

⚠ Caution

1. Check the dripping amount once a day. Drip failure can cause damage to the components that need lubrication.

Construction

JIS symbol

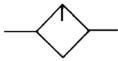

AL10

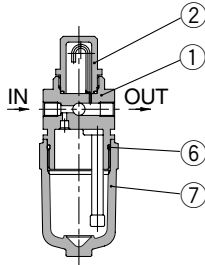

AL20

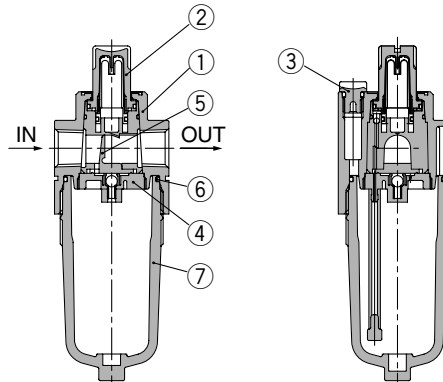

AL30, 40

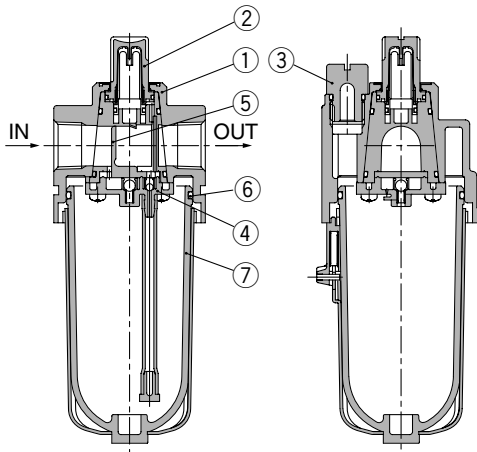

AL50, 60

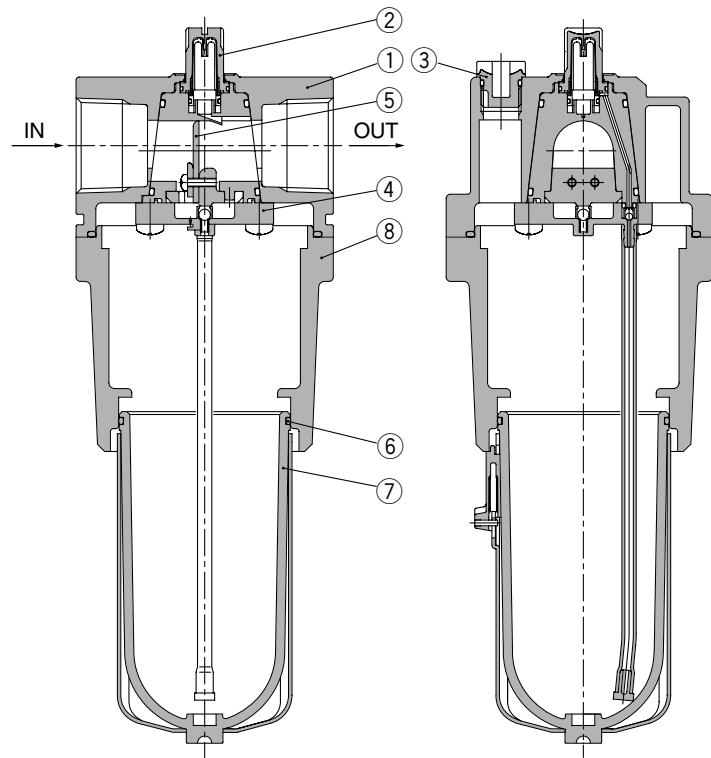

Parts list

No.	Description	Material			Note
		AL10, 20	AL30, 40, 40-06	AL50, 60	
1	Body	Zinc die-cast	Aluminum die-cast		Platinum silver
8	Housing	—		Aluminum die-cast	Platinum silver

Replacement parts

No.	Description	Material	Part no.						
			AL10	AL20	AL30	AL40	AL40-06	AL50	AL60
2	Sight dome assembly	PC	AL10P-080AS	AL20P-080AS	AL20P-080AS	AL20P-080AS	AL20P-080AS	AL20P-080AS	AL20P-080AS
3	Lubrication plug assembly	—	—	AL20P-060AS	AL30P-060AS	AL40P-060AS	AL40P-060AS	AL40P-060AS	AL40P-060AS
4	Damper retainer assembly ^{Note 1)}	—	—	AL20P-030AS	AL30P-030AS	AL40P-030AS	AL40P-030AS	AL50P-030AS	AL60P-030AS
5	Damper assembly	Synthetic resin	—	AL20P-040S	AL30P-040S	AL40P-040S	AL40P-040S	AL50P-040AS	AL60P-040AS
6	Bowl O-ring	NBR	C1SFP-260S	C2SFP-260S	C3SFP-260S	C4SFP-260S	C4SFP-260S	C4SFP-260S	C4SFP-260S
7	Bowl assembly ^{Note 2)}	PC	C1SL	C2SL	C3SL ^{Note 3)}	C4SL ^{Note 3)}	C4SL ^{Note 3)}	C4SL ^{Note 3)}	C4SL ^{Note 3)}

Note 1) Add "-1" at the end of the part number when ordering a damper retainer assembly for 1000cm³.
 Example) AL30P-030AS-1
 Note 2) Including O-Ring. Contact SMC regarding the bowl assembly supply for PSI and °F unit specifications.
 Note 3) Bowl assembly for AL30 to AL60 comes with a bowl guard (steel band material).

AL10 to 60

Dimensions

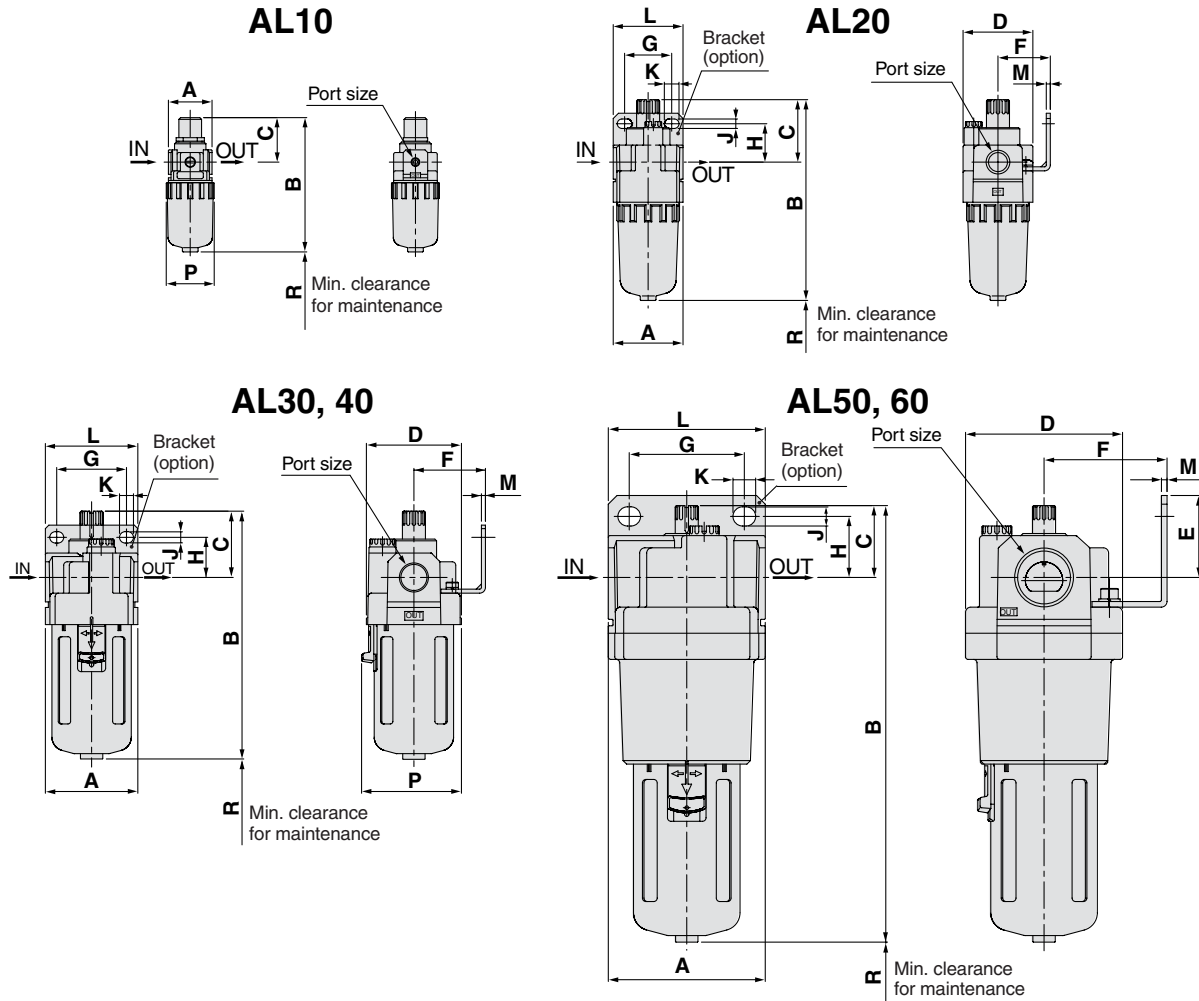

Applicable model	AL10, AL20				AL30, AL40, AL40-06, AL50, AL60				
Optional specifications	With drain cock	Metal bowl with drain cock	Metal bowl	With drain cock	Metal bowl with level gauge	Metal bowl with drain cock	Metal bowl with drain cock & level gauge	Drain cock with barb fitting	
									Barb fitting Applicable tubing: T0604

Model	Port size	Standard specification							Accessory specification						
		A	B	C	D	P	R	E	F	G	H	J	K	L	M
AL10	M5 x 0.8	25	77	26	25	28	35	—	—	—	—	—	—	—	—
AL20	1/8, 1/4	40	115	36	40	—	60	—	30	27	22	5.4	8.4	40	2.3
AL30	1/4, 3/8	53	142	38	53	57	80	—	41	40	23	6.5	8	53	2.3
AL40	1/4, 3/8, 1/2	70	176	40	70	73	110	—	50	54	26	8.5	10.5	70	2.3
AL40-06	3/4	75	176	38	70	73	110	—	50	54	25	8.5	10.5	70	2.3
AL50	3/4, 1	90	250	41	90	—	110	47	70	66	35	11	13	90	3.2
AL60	1	95	268	45	95	—	110	47	70	66	35	11	13	90	3.2

Model	Optional specification					
	With drain cock	With barb fitting	Metal bowl	Metal bowl with drain cock	Metal bowl with level gauge	Metal bowl with drain cock & level gauge
AL10	B	B	B	B	B	B
AL10	85	—	82	85	—	—
AL20	123	—	121	124	—	—
AL30	153	161	142	166	162	186
AL40	187	195	176	200	196	220
AL40-06	187	195	176	200	196	220
AL50	261	269	250	274	270	294
AL60	279	287	268	292	288	312



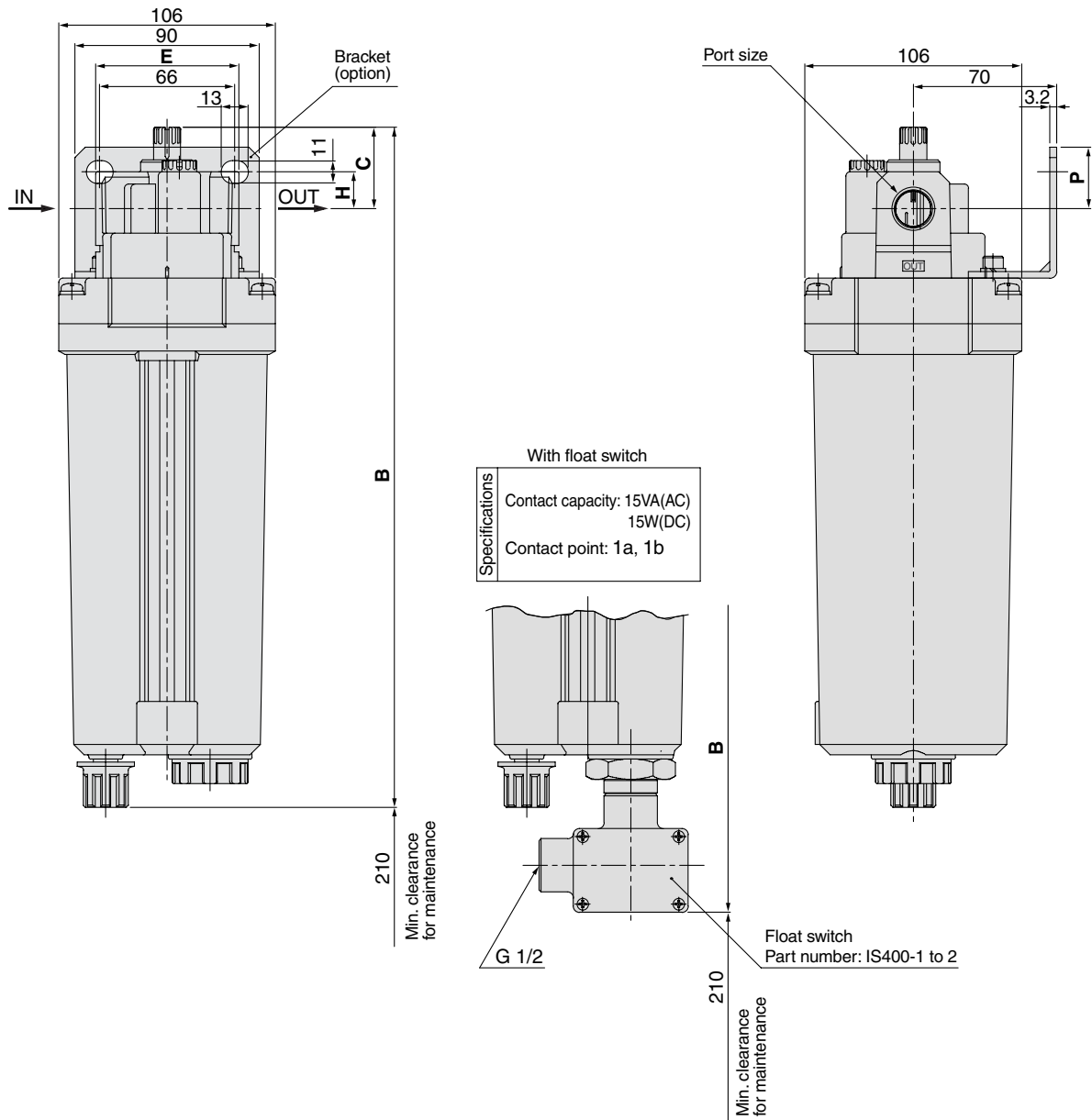

Dimensions

Optional specifications: 1000cm³ tank



Model	Port size	B	C	E	With bracket		With float switch
					H	P	B
AL30	1/4, 3/8	324	38	53	25	—	374
AL40	1/4, 3/8, 1/2	333	40	70	18	—	383
AL40-06	3/4	333	38	75	16	—	383
AL50	3/4, 1	332	41	90	35	47	382
AL60	1	335	45	95	35	47	385

Modular Type Filter Regulator Series AW

Filter regulator Series AW	Model	Port size	Filtration	Accessory
 Pages 56 through 60	AW10	M5 x 0.8	5μm	Bracket Square embedded type pressure gauge (except for AR10) Round pressure gauge Panel mount
	AW20	1/8, 1/4		
	AW30	1/4, 3/8		
	AW40	1/4, 3/8, 1/2		
	AW40-06	3/4		
	 Pages 63 through 66	AW20K		
AW30K		1/4, 3/8		
AW40K		1/4, 3/8, 1/2		
AW40K-06		3/4		
 Pages 67 through 70	AWM20	1/8, 1/4	0.3μm (95% filtered particle size)	Round pressure gauge Panel mount
	AWM30	1/4, 3/8		
	AWM40	1/4, 3/8, 1/2		
 Pages 71 through 74	AWD20	1/8, 1/4	0.01μm (95% filtered particle size)	
	AWD30	1/4, 3/8		
	AWD40	1/4, 3/8, 1/2		

Filter Regulator AW10 to 40

Integrated filter and regulator units save space and require less piping.

Direct operated, relieving type

JIS symbol

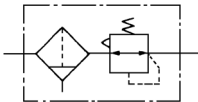

Page 61



AW20



AW40

How to Order

AW 30 — **F 03** **BE** — **1N**

Filter regulator

Body size

10 20 30 40

Thread type

Nil	Metric thread (M5)
	Rc
N Note 1)	NPT
F Note 2)	G

Note 1) Drain guide is NPT1/4 (applicable to AW30 and 40), and the exhaust port for auto drain comes with $\phi 3/8"$ One-touch fitting (applicable to AW30 and AW40).

Note 2) Drain guide is G1/4 (applicable to AW30 and AW40).

Port size

Symbol	Port size	Body size			
		10	20	30	40
M5	M5	●	—	—	—
01	1/8	—	●	—	—
02	1/4	—	●	●	●
03	3/8	—	—	●	●
04	1/2	—	—	—	●
06	3/4	—	—	—	●

Optional specifications

Symbol	Description	Applicable model
1 ^{Note 5)}	0.02 to 0.2MPa setting	AW10 to 40
2	Metal bowl	AW10 to 40
6	Nylon bowl	AW10 to 40
8	Metal bowl with level gauge	AW30, 40
C	With bowl guard	AW20
J ^{Note 6)}	Drain guide 1/4	AW30, 40
N	Non-relieving	AW10 to 40
R	Flow direction: Right to left	AW10 to 40
W	Drain cock with barb fitting: $\phi 6 \times \phi 4$ nylon tubing	AW30, 40
Z ^{Note 7)}	Name plate, caution plate for bowl, and pressure gauge in imperial units (PSI, °F)	AW10 to 40

* When more than one specification is required, indicate in alphanumeric order.
 Note 5) The only difference from the standard specifications is the adjusting spring for the regulator. It does not restrict the setting of 0.2MPa or more.
 Note 6) Without a valve function.
 Note 7) For M5 and NPT thread types.
 This product is for overseas use only according to the new Measurement Law. (The SI unit type is provided for use in Japan.)

Accessories^{Note 3)}

Symbol	Description	Applicable model
Nil	—	—
B	With bracket	AW10 to 40
C	Float type auto drain (N.C.) ^{Note 4)}	AW10 to 40
D	Float type auto drain (N.O.) ^{Note 4)}	AW30, 40
E	With square embedded type pressure gauge (with limit indicator)	AW20 to 40
G	With round pressure gauge (without limit indicator)	AW10
	With round pressure gauge (with limit indicator)	AW20 to 40
H	With set nut (for panel mount)	AW10 to 40

Note 3) Optional parts are not assembled and are supplied loose at the time of shipment (except for options C, D and E).
 Note 4) Applicable tube O.D for auto drain connection should be $\phi 3/8"$ in case NPT thread port is chosen.

Accessory/Optional specification combinations

⊙: Combination available
 ○: Varies depending on the model
 ◻: Combination not available
 △: Available only with NPT thread

Accessory/Optional specifications	Combination	Symbol	Accessory							Optional specification							Applicable filter regulator			
			B	C	D	E	G	H	1	2	6	8	C	J	N	R	W	Z	AW10	AW20
Accessories	With bracket (with set nut)	B	⊙	⊙	⊙	⊙	⊙	⊙	⊙	⊙	⊙	⊙	⊙	⊙	⊙	⊙	⊙	⊙	⊙	⊙
	Float type auto drain (N.C.)	C	⊙	⊙	⊙	⊙	⊙	⊙	⊙	⊙	⊙	⊙	⊙	⊙	⊙	⊙	⊙	⊙	⊙	⊙
	Float type auto drain (N.O.)	D	⊙	⊙	⊙	⊙	⊙	⊙	⊙	⊙	⊙	⊙	⊙	⊙	⊙	⊙	⊙	⊙	⊙	⊙
	Square embedded type pressure gauge	E	⊙	⊙	⊙	⊙	⊙	⊙	⊙	⊙	⊙	⊙	⊙	⊙	⊙	⊙	⊙	⊙	⊙	⊙
	Round pressure gauge	G	⊙	⊙	⊙	⊙	⊙	⊙	⊙	⊙	⊙	⊙	⊙	⊙	⊙	⊙	⊙	⊙	⊙	⊙
	With set nut (for panel mount)	H	⊙	⊙	⊙	⊙	⊙	⊙	⊙	⊙	⊙	⊙	⊙	⊙	⊙	⊙	⊙	⊙	⊙	⊙
Optional specifications	0.02 to 0.2MPa setting	-1	⊙	⊙	⊙	⊙	⊙	⊙	⊙	⊙	⊙	⊙	⊙	⊙	⊙	⊙	⊙	⊙	⊙	
	Metal bowl	-2	⊙	⊙	⊙	⊙	⊙	⊙	⊙	⊙	⊙	⊙	⊙	⊙	⊙	⊙	⊙	⊙	⊙	
	Nylon bowl	-6	⊙	⊙	⊙	⊙	⊙	⊙	⊙	⊙	⊙	⊙	⊙	⊙	⊙	⊙	⊙	⊙	⊙	
	Metal bowl with level gauge	-8	⊙	⊙	⊙	⊙	⊙	⊙	⊙	⊙	⊙	⊙	⊙	⊙	⊙	⊙	⊙	⊙	⊙	
	With bowl guard	-C	⊙	⊙	⊙	⊙	⊙	⊙	⊙	⊙	⊙	⊙	⊙	⊙	⊙	⊙	⊙	⊙	⊙	
	Drain guide 1/4	-J	⊙	⊙	⊙	⊙	⊙	⊙	⊙	⊙	⊙	⊙	⊙	⊙	⊙	⊙	⊙	⊙	⊙	
	Non-relieving type	-N	⊙	⊙	⊙	⊙	⊙	⊙	⊙	⊙	⊙	⊙	⊙	⊙	⊙	⊙	⊙	⊙	⊙	
	Flow direction: Right to left	-R	⊙	⊙	⊙	⊙	⊙	⊙	⊙	⊙	⊙	⊙	⊙	⊙	⊙	⊙	⊙	⊙	⊙	
	Drain cock with barb fitting: $\phi 6 \times \phi 4$ nylon tubing	-W	⊙	⊙	⊙	⊙	⊙	⊙	⊙	⊙	⊙	⊙	⊙	⊙	⊙	⊙	⊙	⊙	⊙	
	Name plate, caution plate for bowl, and pressure gauge in imperial units (PSI, °F)	-Z	△	△	△	△	△	△	△	△	△	△	△	△	△	△	△	△	△	△

AW10 to 40

Standard specifications

Model	AW10	AW20	AW30	AW40	AW40-06
Port sizes	M5 x 0.8	1/8, 1/4	1/4, 3/8	1/4, 3/8, 1/2	3/4
Fluid	Air				
Proof pressure	1.5MPa				
Maximum operating pressure	1.0MPa				
Set pressure range	0.05 to 0.7MPa	0.05 to 0.85MPa			
Pressure gauge port size ^{Note 1)}	Rc 1/16 ^{Note 2)}	Rc, NPT, G 1/8	Rc, NPT, G 1/8	Rc, NPT, G 1/4	Rc, NPT, G 1/4
Relief pressure	Set pressure + 0.05MPa ^{Note 3)} [at relief flow rate of 0.1L/min (ANR)]				
Ambient and fluid temperature	-5 to 60°C (with no freezing)				
Nominal filtration rating	5µm				
Drain capacity (cm ³)	2.5	8	25	45	45
Bowl material	Polycarbonate				
Bowl guard	—	Option	Standard		
Construction	Relieving type				
Weight (kg)	0.09	0.32	0.40	0.72	0.75

Note 1) Pressure gauge connection threads are not required for regulators with a square embedded type pressure gauge (AW20 to AW40).

Note 2) Use a bushing (part no: 131368) when connecting R 1/8 pressure gauge to R 1/16 gauge port.

Note 3) Not applicable to AW10.

Accessory part no.

Applicable model		AW10	AW20	AW30	AW40	AW40-06			
Accessory									
Bracket assembly ^{Note 1)}		AR10P-270AS	AW20P-270AS	AR30P-270AS	AR40P-270AS	AR40P-270AS			
Set nut		AR10P-260S	AR20P-260S	AR30P-260S	AR40P-260S	AR40P-260S			
Pressure gauge	1.0MPa	Round	G27-10-R1	G36-10-□01	G36-10-□01	G46-10-□02	G46-10-□02		
		Square embedded type ^{Note 4)}	—	GC3-10AS	GC3-10AS	GC3-10AS	GC3-10AS		
	0.2MPa	Round	G27-10-R1 ^{Note 3)}	G36-2-□01	G36-2-□01	G46-2-□02	G46-2-□02		
		Square embedded type ^{Note 4)}	—	GC3-2AS	GC3-2AS	GC3-2AS	GC3-2AS		
Float type auto drain ^{Note 5)}	N.O.	—	—	AD38	AD38N ^{Note 6)}	AD48	AD48N ^{Note 6)}	AD48	AD48N ^{Note 6)}
	N.C.	AD17	AD27	AD37	AD37N ^{Note 6)}	AD47	AD47N ^{Note 6)}	AD47	AD47N ^{Note 6)}

Note 1) Assembly includes a bracket and set nuts.

Note 2) □ in part numbers for a round pressure gauge indicates a type of connection thread. No indication is necessary for R; however, indicate N for NPT. Contact SMC regarding the connection thread NPT and supply of the pressure gauge for PSI unit specifications.

Note 3) For 1MPa.

Note 4) Includes one O-ring and 2 mounting screws.

Note 5) Minimum operating pressure: N.O. type-0.1MPa; N.C. type-0.1MPa (AD17/27) and 0.15MPa (AD37/47). Contact SMC regarding the specifications for PSI unit and °F.

Note 6) When "N" is specified in the end of part number of auto drain, applicable tube O.D should be ø3/8".

⚠ Specific Product Precautions

Be sure to read before handling. Refer to pages 75 through 78 for safety instructions and F.R.L. unit precautions.

Selection

⚠ Warning

- Residual pressure release (outlet pressure release) is not completed by releasing inlet pressure. To release residual pressure, use a filter regulator with a back flow mechanism.

Maintenance

⚠ Warning

- Replace the element every 2 years or when the pressure drop becomes 0.1MPa, whichever comes first, to prevent damage to the element.

Mounting & Adjustment

⚠ Warning

- Set the regulator while checking the displayed values of the inlet and outlet pressure gauges. Turning the knob excessively can cause damage to the internal parts.
- The pressure gauge indicated with regulators for 0.02 to 0.2MPa setting is for 0.2MPa use only. Exceeding 0.2MPa of pressure can damage the gauge.
- Do not use tools on the pressure regulator knob as this may cause damage. It must be operated manually.

⚠ Caution

- Be sure to unlock the knob before adjusting the pressure and lock it after setting the pressure. Failure to follow this procedure can cause damage to the knob and the outlet pressure may fluctuate.

- Pull the pressure regulator knob to unlock. (You can visually verify this with the "orange mark" that appears in the gap.)
- Push the pressure regulator knob to lock. When the knob is not easily locked, turn it left and right a little and then push it (when the knob is locked, the "orange mark" will disappear).



- A knob cover is available to prevent careless operation of the knob. Refer to Features 1 for details.

Flow Characteristics (Representative values)

Condition: Inlet pressure 0.7MPa

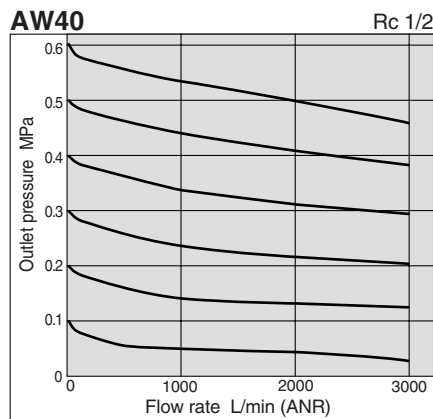
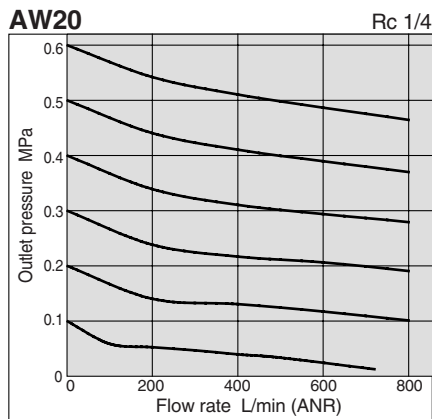
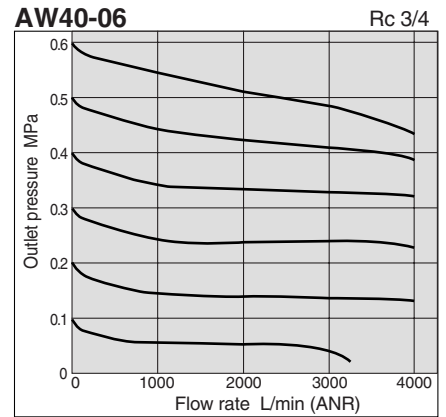
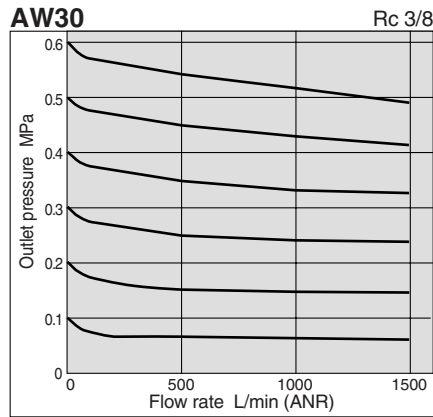
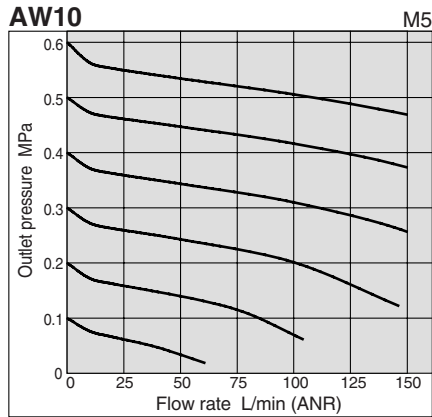

Pressure Characteristics (Representative value)

Conditions: Inlet pressure 0.7MPa; Outlet pressure 0.2MPa; Flow rate 20L/min (ANR)

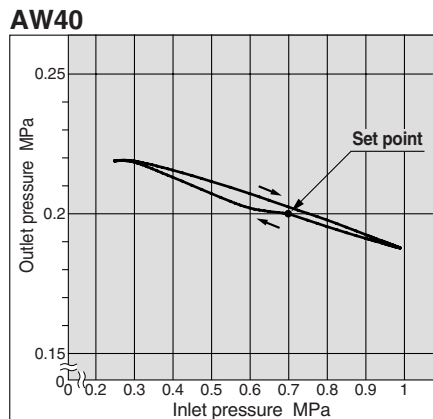
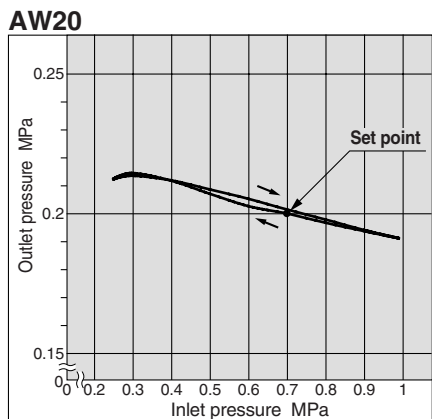
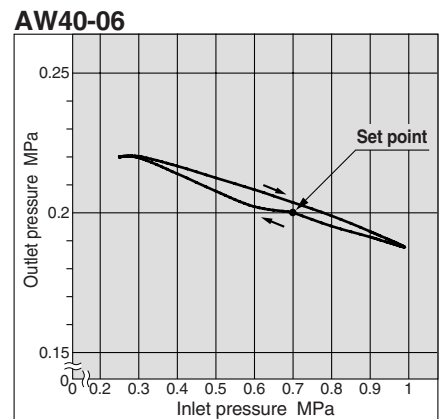
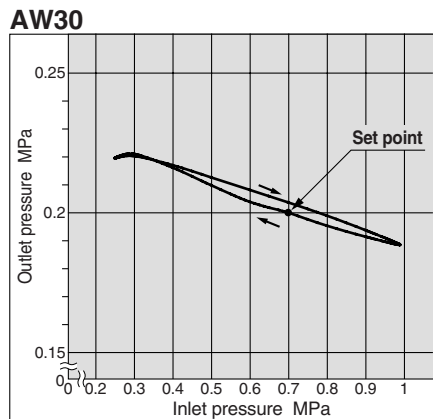
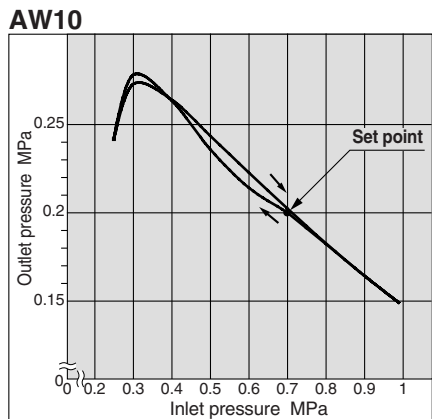

AW10 to 40

Construction

JIS symbol

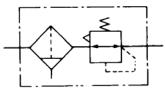

AW10

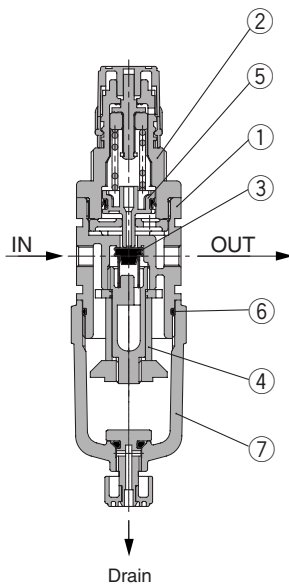

AW20

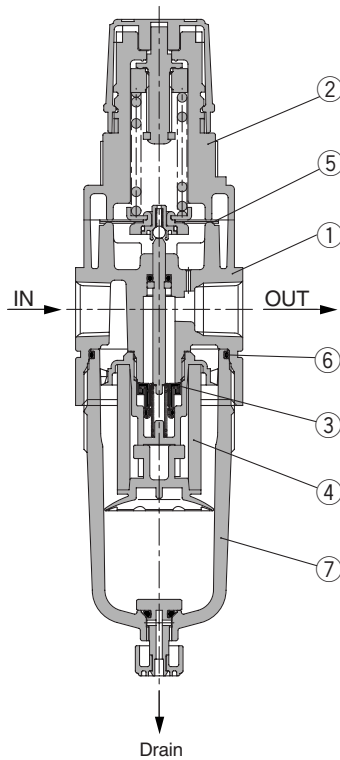

AW30, 40

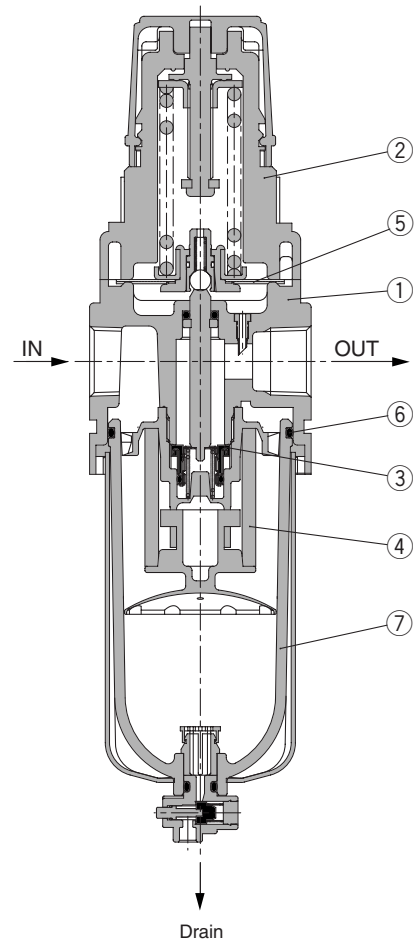

Parts list

No.	Description	Material			Note
		AW10, 20	AW30	AW40, 40-06	
1	Body	Zinc die-cast	Aluminum die-cast		Platinum silver
2	Bonnet	Polyacetal			Black

Replacement parts

No.	Description	Material	Part no.				
			AW10	AW20	AW30	AW40	AW40-06
3	Valve assembly	Stainless steel Brass, HNBR	AR10P-090S	AW20P-090AS	AW30P-090AS	AW40P-090AS	AW40P-090AS
4	Filter element	Non-woven fabric	AF10P-060S	AF20P-060S	AF30P-060S	AF40P-060S	AF40P-060S
5	Diaphragm assembly	Weatherability NBR	AR10P-150AS <small>Note 1)</small>	AR20P-150AS	AR30P-150AS	AR40P-150AS	AR40P-150AS
6	Bowl O-ring	NBR	C1SFP-260S	C2SFP-260S	C3SFP-260S	C4SFP-260S	C4SFP-260S
7	Bowl assembly <small>Note 2)</small>	PC	C1SF	C2SF	C3SF <small>Note 3)</small>	C4SF <small>Note 3)</small>	C4SF <small>Note 3)</small>



Note 1) AW10 is a piston and a gasket (KSY-P-13) type assembly.

Note 2) Including O-Ring. Contact SMC regarding the bowl assembly supply for PSI and °F unit specifications.

Note 3) The AW30 and AW40 bowl assembly comes with a bowl guard (steel band material).

Dimensions

AW10, 20

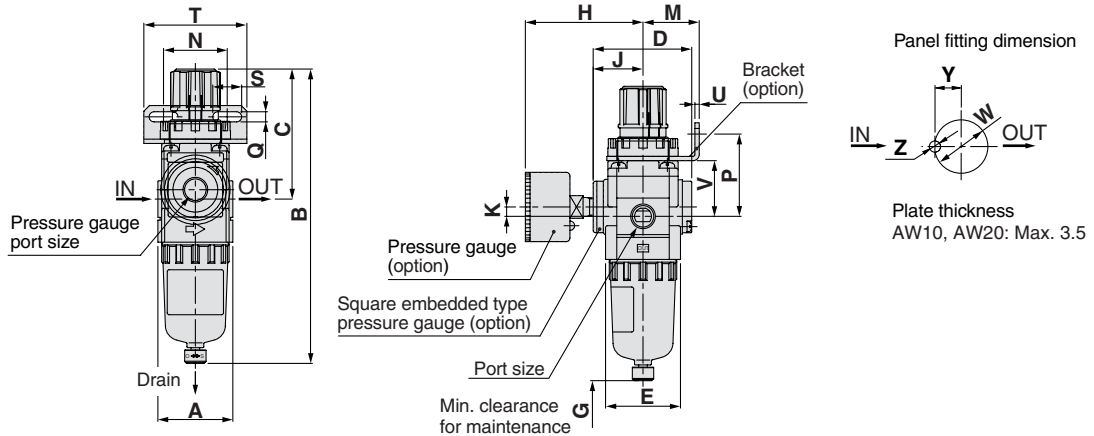

AW30, 40

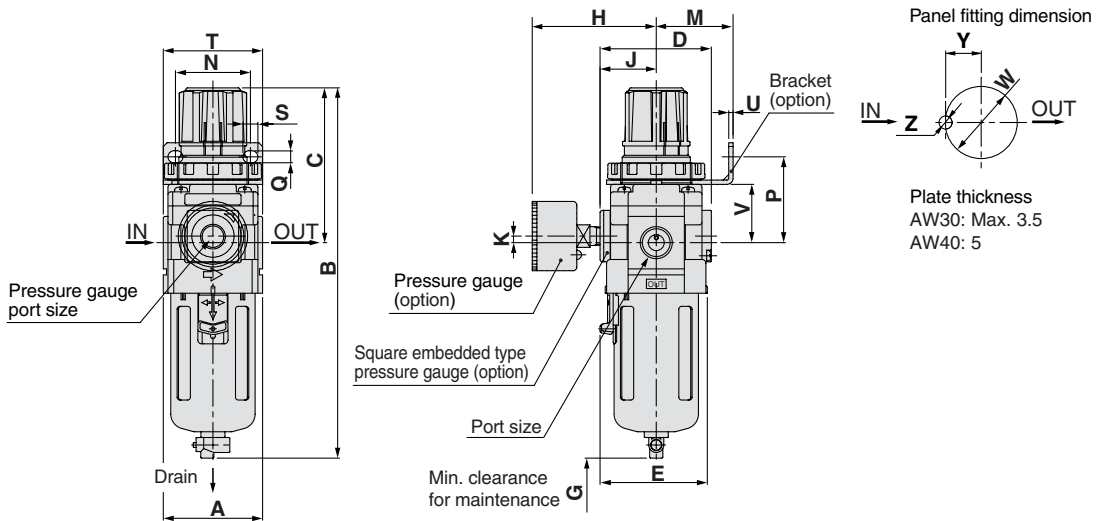

Applicable model	AW10, AW20				AW30, AW40, AW40-06			
Optional specifications	With auto drain (N.C.)	Metal bowl	With auto drain (N.O./N.C.)	Metal bowl	Metal bowl with level gauge	With drain guide	Drain cock with barb fitting	
			 N.O.: Black N.C.: Gray ø10 One-touch fitting			 Width across flats 17	 Barb fitting Applicable tubing: T0604	

Model	Port size	Standard specification						Accessory specification														
		A	B	C	D	E	G	With pressure gauge			Bracket mounting size						Panel mount			With auto drain		
		H	J	K	M	N	P	Q	S	T	U	V	W	Y	Z	B						
AW10	M5 x 0.8	25	108	48	25	28	25	26	—	0	25	28	30	4.5	6.5	40	2	18	18.5	—	—	125
AW20	1/8, 1/4	40	160	73	52	40	40	63	27	5	30	34	44	5.4	15.4	55	2.3	30	28.5	14	6	177
AW30	1/4, 3/8	53	201	86	59	57	55	66	30.5	3.5	41	40	46	6.5	8	53	2.3	31	38.5	19	7	242
AW40	1/4, 3/8, 1/2	70	239	92	75	73	80	76	38.5	1.5	50	54	54	8.5	10.5	70	2.3	35.5	42.5	21	7	278
AW40-06	3/4	75	242	93	75	73	80	76	38.5	1.2	50	54	56	8.5	10.5	70	2.3	37	42.5	21	7	278

Model	Optional specification				
	With barb fitting	With drain guide	Metal bowl	Metal bowl with level gauge	
		B	B	B	B
AW10	—	—	107	—	
AW20	—	—	160	—	
AW30	209	208	214	234	
AW40	247	246	251	272	
AW40-06	250	249	255	275	

Filter Regulator AW20 to 40 Made to Order Specifications

Contact SMC for detailed dimensions, specifications, and lead times.



① Special Temperature Environment

Special materials are used in the manufacturing of seals and resin parts to allow them to withstand various temperature conditions in cold or tropical (hot) regions.

Specifications

Part no.	-X430	-X440
Environment	Low temperature	High temperature
Ambient temperature	-30 to 60°C	-5 to 80°C
Fluid temperature	-5 to 60°C (with no freezing)	
Material	Rubber parts	Special NBR
	Main parts	Aluminum die-cast

Applicable models

Model	AW30	AW40	AW40-06
Port size	1/4, 3/8	1/4, 3/8, 1/2	3/4

How to Order

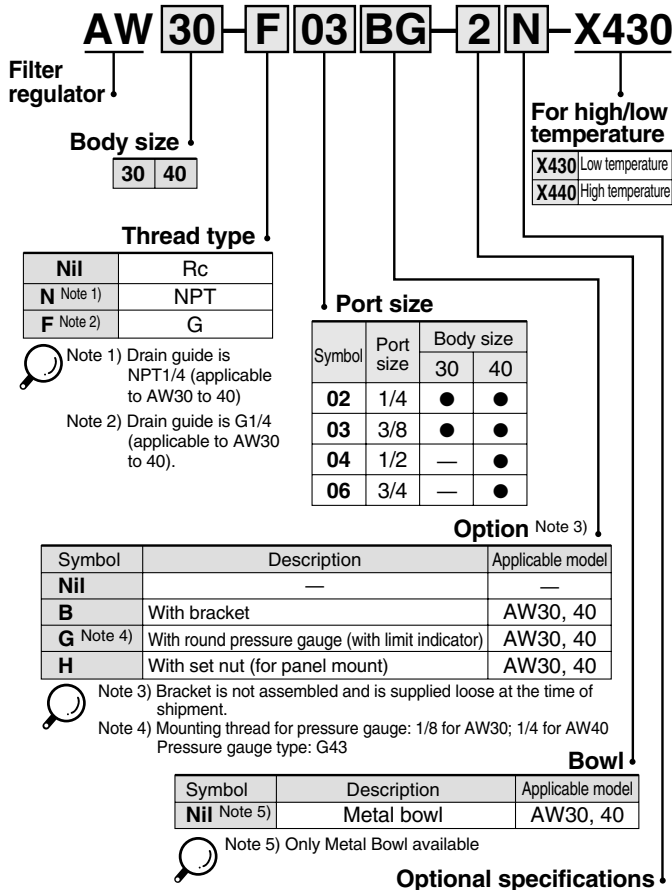

* When more than one specification is required, indicate in ascending alphanumeric order.
 Note 6) The only difference from the standard specifications is the adjusting spring for the regulator. It does not restrict the setting of 0.2MPa or more.
 Note 7) Without a valve function.
 Note 8) For thread type NPT.
 This product is for overseas use only according to the new Measurement Law. (The SI unit type is provided for use in Japan.)

② High Pressure

Strong materials are used in the manufacturing of air filters intended for high pressure operation.

Specifications

Part no.	-X425
Proof pressure	3.0MPa
Maximum operating pressure	2.0MPa
Set pressure range	0.1 to 1.6MPa
Ambient and fluid temperature	-5 to 60°C (with no freezing)



Applicable models

Model	AW20	AW30	AW40	AW40-06
Port size	1/8, 1/4	1/4, 3/8	1/4, 3/8, 1/2	3/4

How to Order

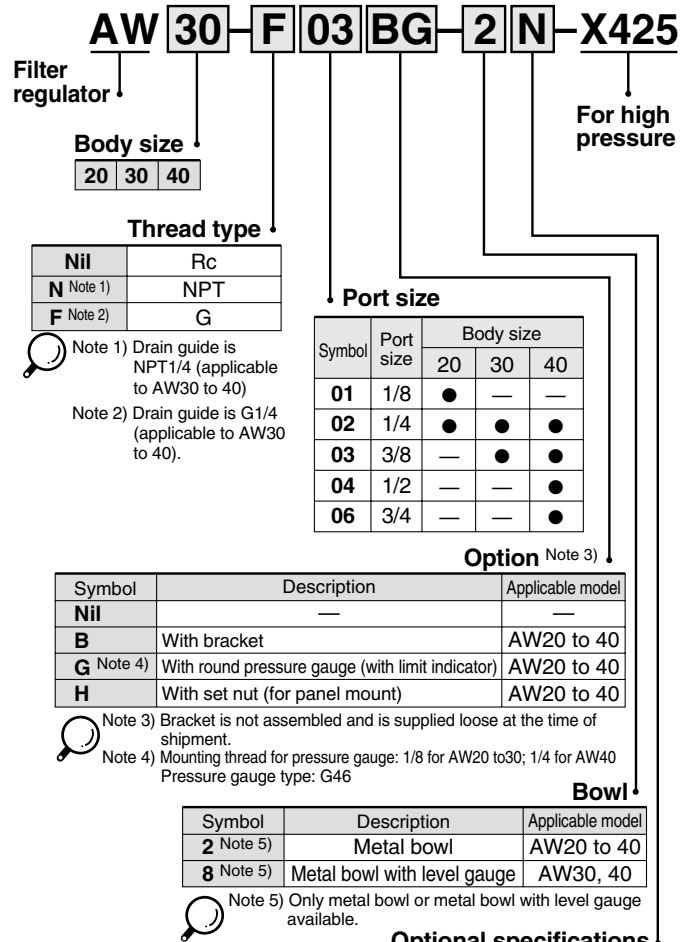

* When more than one specification is required, indicate in ascending alphanumeric order.
 Note 6) Without a valve function.
 Note 7) For thread type NPT.
 This product is for overseas use only according to the new Measurement Law. (The SI unit type is provided for use in Japan.)

Note 9) Consult SMC for detailed dimensions and available attachments and options.
 Note 10) Comes with T type handle.

Filter Regulator AW20(K) to AW40(K) Made to Order Specifications

Contact SMC for detailed dimensions, specifications, and lead times.



③ With Digital Pressure Switch

Digital pressure switch (ISE30-□□-□□-□□L) is supplied loose for mounting on pressure gauge connection port.

Specifications

Part number suffix		-X465
Pressure switch	Model	ISE30-□□-□□-□□L
	Set pressure range (MPa)	-0.1 to 1
	Set and display resolution (MPa)	0.001
	Power supply voltage	12 to 24 VDC ± 10%, Ripple (p-p) 10% or less (with power supply polarity protection)
	Power consumption	45 mA or less (70 mA or less for current output)

*Pressure gauge port size: 1/8

Applicable models

Model	AW20(K)	AW30(K)	AW40(K)	AW40(K)-06
Port size	1/8, 1/4	1/4, 3/8	1/4, 3/8, 1/2	3/4



How to Order

AW 30 K - F 03 B - 1N - X465 A

Filter regulator

Body size
20 30 40

With back flow mechanism

Nil	—
K	With back flow mechanism

Switch specifications

Symbol	Output specifications
A	NPN output
B	PNP output
C	1 to 5V output
D	4 to 20mA output

With digital pressure switch (Series ISE30)

Note 7) Optional parts are not assembled and are supplied loose at the time of shipment.

Thread type

Nil	Rc
N Note 1)	NPT
F Note 2)	G



Note 1) Drain guide is NPT1/4 (applicable to AW30 to 40), and the exhaust port for auto drain comes with ø3/8" One-touch fitting (applicable to AW30 to 40).

Note 2) Drain guide is G1/4 (applicable to AW30 to 40).

Port size

Symbol	Port size	Body size		
		20	30	40
01	1/8	●	●	—
02	1/4	●	●	●
03	3/8	—	●	●
04	1/2	—	—	●
06	3/4	—	—	●

Optional specifications

Symbol	Description	Applicable model
1 Note 4)	0.02 to 0.2MPa setting	AW20(K) to 40(K)
2	Metal bowl	AW20(K) to 40(K)
6	Nylon bowl	AW20(K) to 40(K)
8	Metal bowl with level gauge	AW30(K), 40(K)
C	With bowl guard	AW20(K)
J Note 5)	Drain guide 1/4	AW30(K), 40(K)
N	Non-relieving type	AW20(K) to 40(K)
R	Flow direction: Right to left	AW20(K) to 40(K)
W	Drain cock with barb fitting: ø6 x ø4 nylon tubing	AW30(K), 40(K)
Z Note 6)	Name plate and caution plate for bowl in imperial units (PSI, °F)	AW20(K) to 40(K)



* When more than one specification is required, indicate in ascending alphanumeric order.
Note 4) The only difference from the standard specifications is the adjusting spring for the regulator. It does not restrict the setting of 0.2MPa or more.

Note 5) Without a valve function.

Note 6) For thread type NPT.

This product is for overseas use only according to the new Measurement Law. (The SI unit type is provided for use in Japan.)

Option Note 3)

Symbol	Description	Applicable model
Nil	—	—
B	With bracket	AW20(K) to 40(K)
C	Float type auto drain (N.C.) Note 4)	AW20(K) to 40(K)
D	Float type auto drain (N.O.) Note 4)	AW30(K), 40(K)
H	With set nut (for panel mount)	AW20(K) to 40(K)



Note 3) Optional parts are not assembled and are supplied loose at the time of shipment (except for options C and D)

Note 4) Applicable tube O.D for auto drain connection should be ø3/8" in case NPT thread port is chosen.

Note 8) Consult SMC for detailed dimensions and available attachments and options.

Note 9) Refer to SMC catalog CAT.ES100-42 for detailed specifications and instructions of digital pressure switch.

Filter Regulator with Back Flow Mechanism

AW20K/30K/40K

How to Order



AW40K



AW20K

AW 30 K - F 03 BE - 1N

Filter regulator

Body size

20 30 40

With back flow mechanism

Note) AW10 comes with a back flow mechanism as a standard feature. If the set pressure is not exceeding 0.15MPa, back flow may not occur. When a back flow mechanism is required with a set pressure of less than 0.15MPa, contact SMC.



Thread type

Nil	Rc
N Note 1)	NPT
F Note 2)	G

Note 1) Drain guide is NPT 1/4 (applicable to AW30K and 40K), and the exhaust port for auto drain comes with ø3/8" One-touch fitting (applicable to AW30K and AW40K).

Note 2) Drain guide is G 1/4 (applicable to AW30K and AW40K).

Port size

Symbol	Port size	Body size		
		20	30	40
01	1/8	●	—	—
02	1/4	●	●	●
03	3/8	—	●	●
04	1/2	—	—	●
06	3/4	—	—	●

Optional specifications

Symbol	Description	Applicable model
1 Note 4)	0.02 to 0.2MPa setting	AW20K to 40K
2	Metal bowl	AW20K to 40K
6	Nylon bowl	AW20K to 40K
8	Metal bowl with level gauge	AW30K, 40K
C	With bowl guard	AW20K
J Note 5)	Drain guide 1/4	AW30K, 40K
N	Non-relieving type	AW20K to 40K
R	Flow direction: Right to left	AW20K to 40K
W	Drain cock with barb fitting: ø6 x ø4 nylon tubing	AW30K, 40K
Z Note 6)	Name plate, caution plate for bowl, and pressure gauge in imperial units (PSI, °F)	AW20K to 40K

* When more than one specification is required, indicate in alphanumeric order.
 Note 4) The only difference from the standard specifications is the adjusting spring for the regulator. It does not restrict the setting of 0.2MPa or more.
 Note 5) Without a valve function.
 Note 6) For NPT thread type.
 This product is for overseas use only according to the new Measurement Law. (The SI unit type is provided for use in Japan.)

Accessories Note 3)

Symbol	Description	Applicable model
Nil	—	—
B	With bracket	AW20K to 40K
C	Float type auto drain (N.C.) Note 2)	AW20K to 40K
D	Float type auto drain (N.O.) Note 2)	AW30K, 40K
E	With square embedded type pressure gauge (with limit indicator)	AW20K to 40K
G	With round pressure gauge (with limit indicator)	AW20K to 40K
H	With set nut (for panel mount)	AW20K to 40K

Note 1) Optional parts are not assembled and are supplied loose at the time of shipment (except for options C, D and E).
 Note 2) Applicable tube O.D for auto drain connection should be ø3/8" in case NPT thread port is chosen.

Standard specifications

Model	AW20K	AW30K	AW40K	AW40K-06
Port sizes	1/8, 1/4	1/4, 3/8	1/4, 3/8, 1/2	3/4
Fluid	Air			
Proof pressure	1.5MPa			
Maximum operating pressure	1.0MPa			
Set pressure range Note 1)	0.05 to 0.85MPa			
Pressure gauge port size Note 2)	Rc, NPT, G 1/8	Rc, NPT, G 1/8	Rc, NPT, G 1/4	Rc, NPT, G 1/4
Relief pressure	Set pressure + 0.05MPa [at relief flow rate of 0.1L/min (ANR)]			
Ambient and fluid temperature	-5 to 60°C (with no freezing)			
Nominal filtration rating	5µm			
Drain capacity (cm ³)	8	25	45	45
Bowl material	Polycarbonate			
Bowl guard	Option	Standard		
Construction	Relieving type			
Weight (kg)	0.32	0.40	0.72	0.75

Note 1) Set the inlet pressure 0.05MPa or higher than the set pressure.
 Note 2) Pressure gauge connection threads are not required for regulators with a square embedded type pressure gauge (AW20K to AW40K).

Symbol

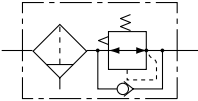

Circuit diagram

When the air supply is cut off and releasing the inlet pressure to the atmosphere, the residual pressure release of the outlet side can be ensured for a safety purpose.

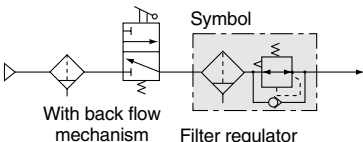

Accessory part no.

Applicable model		AW20K	AW30K	AW40K	AW40K-06	
Accessory						
Bracket assembly Note 1)		AW20P-270AS	AR30P-270AS	AR40P-270AS	AR40P-270AS	
Set nut		AR20P-260S	AR30P-260S	AR40P-260S	AR40P-260S	
Pressure gauge Note 2)	1.0MPa	Round	G36-10-□01	G36-10-□01	G46-10-□02	
		Square embedded type Note 3)	GC3-10AS	GC3-10AS	GC3-10AS	GC3-10AS
	0.2MPa	Round	G36-2-□01	G36-2-□01	G46-2-□02	G46-2-□02
		Square embedded type Note 3)	GC3-2AS	GC3-2AS	GC3-2AS	GC3-2AS
Float type auto drain Note 4)	N.O.	—	AD38 AD38N ^{Note 5)}	AD48 AD48N ^{Note 5)}	AD48 AD48N ^{Note 5)}	
	N.C.	AD27	AD37 AD37N ^{Note 5)}	AD47 AD47N ^{Note 5)}	AD47 AD47N ^{Note 5)}	

Note 1) Assembly includes a bracket and set nuts.
 Note 2) □ in part numbers for a round pressure gauge indicates a type of connection thread. No indication is necessary for R; however, indicate N for NPT. Contact SMC regarding the connection thread NPT and pressure gauge supply for PSI unit specifications.
 Note 3) Includes one O-ring and 2 mounting screws.
 Note 4) Minimum operating pressure: N.O. type-0.1MPa; N.C. type-0.1MPa (AD27) and 0.15MPa (AD37/47). Contact SMC regarding the specifications for PSI unit and "F".
 Note 5) When "N" is specified in the end of part number of auto drain, applicable tube O.D should be ø3/8".

Flow Characteristics (Representative values)

Condition:
Inlet pressure 0.7MPa

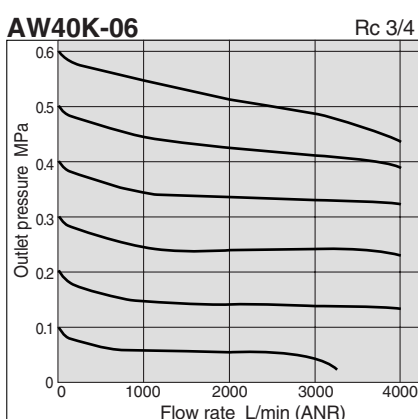
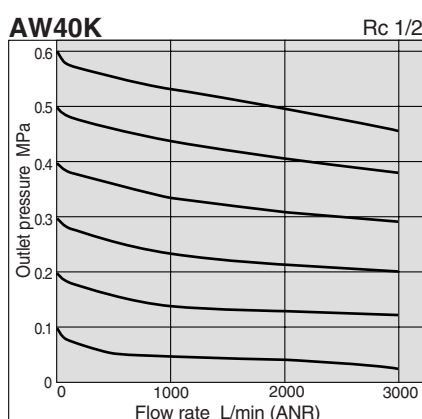
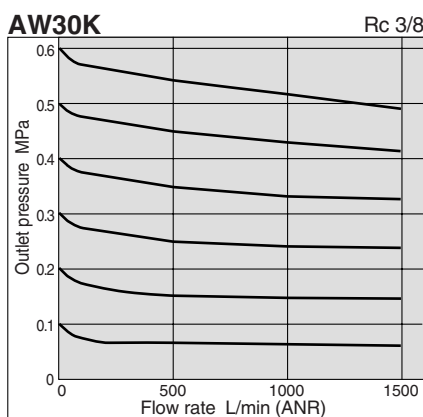
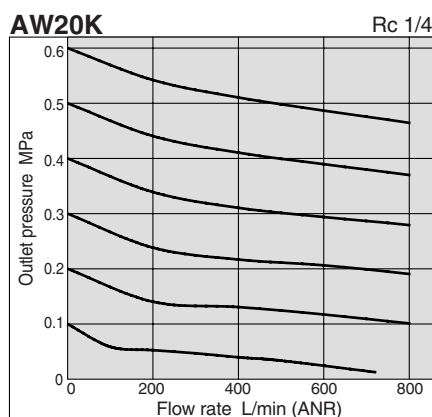

Conditions: Inlet pressure 0.7MPa
Outlet pressure 0.2MPa
Flow rate 20L/min (ANR)

Pressure Characteristics (Representative values)

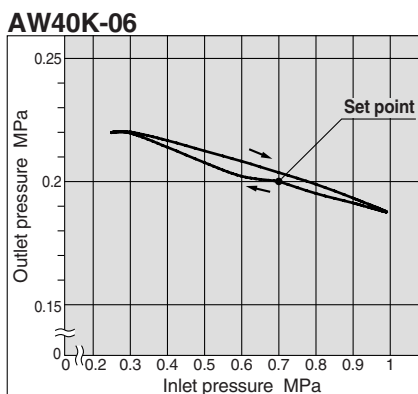
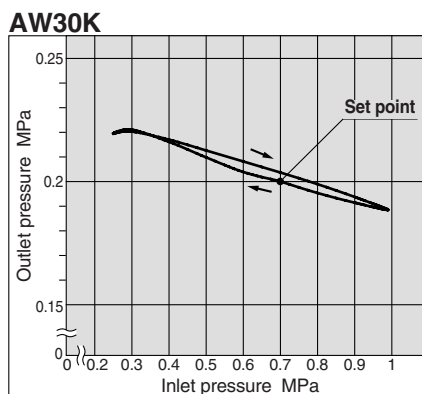
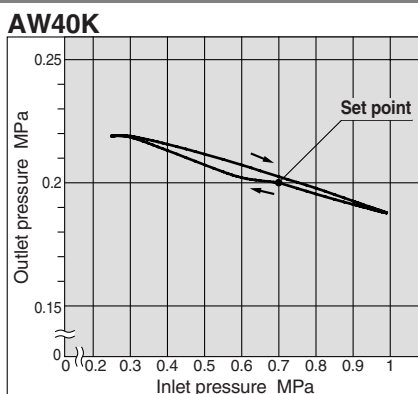
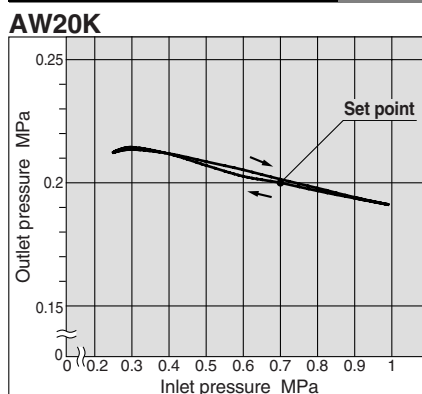

⚠ Specific Product Precautions

Be sure to read before handling.
Refer to pages 75 through 78 for safety instructions and F.R.L. unit precautions.

Mounting & Adjustment

⚠ Warning

1. Set the regulator while checking the displayed values of the inlet and outlet pressure gauges. Turning the knob excessively can cause damage to the internal parts.
2. The pressure gauge included with regulators for 0.02 to 0.2MPa setting is for up to 0.2MPa use. Exceeding 0.2MPa of pressure can damage the gauge.
3. Do not use tools on the pressure regulator knob as this may cause damage. It must be operated manually.

⚠ Caution

1. Be sure to unlock the knob before adjusting the pressure and lock it after setting the pressure.
Failure to follow this procedure can cause damage to the knob and the outlet pressure may fluctuate.
- Pull the pressure regulator knob to unlock. (You can visually verify this with the "orange mark" that appears in the gap.)
 - Push the pressure regulator knob to lock. When the knob is not easily locked, turn it left and right a little and then push it (when the knob is locked, the "orange mark", i.e., the gap will disappear).



2. A knob cover is available to prevent careless operation of the knob. Refer to Features 1 for details.

Maintenance

⚠ Warning

1. Replace the element every 2 years or when the pressure drop becomes 0.1MPa, whichever comes first to prevent damage to the element.

AW20K/30K/40K

Operating Principle

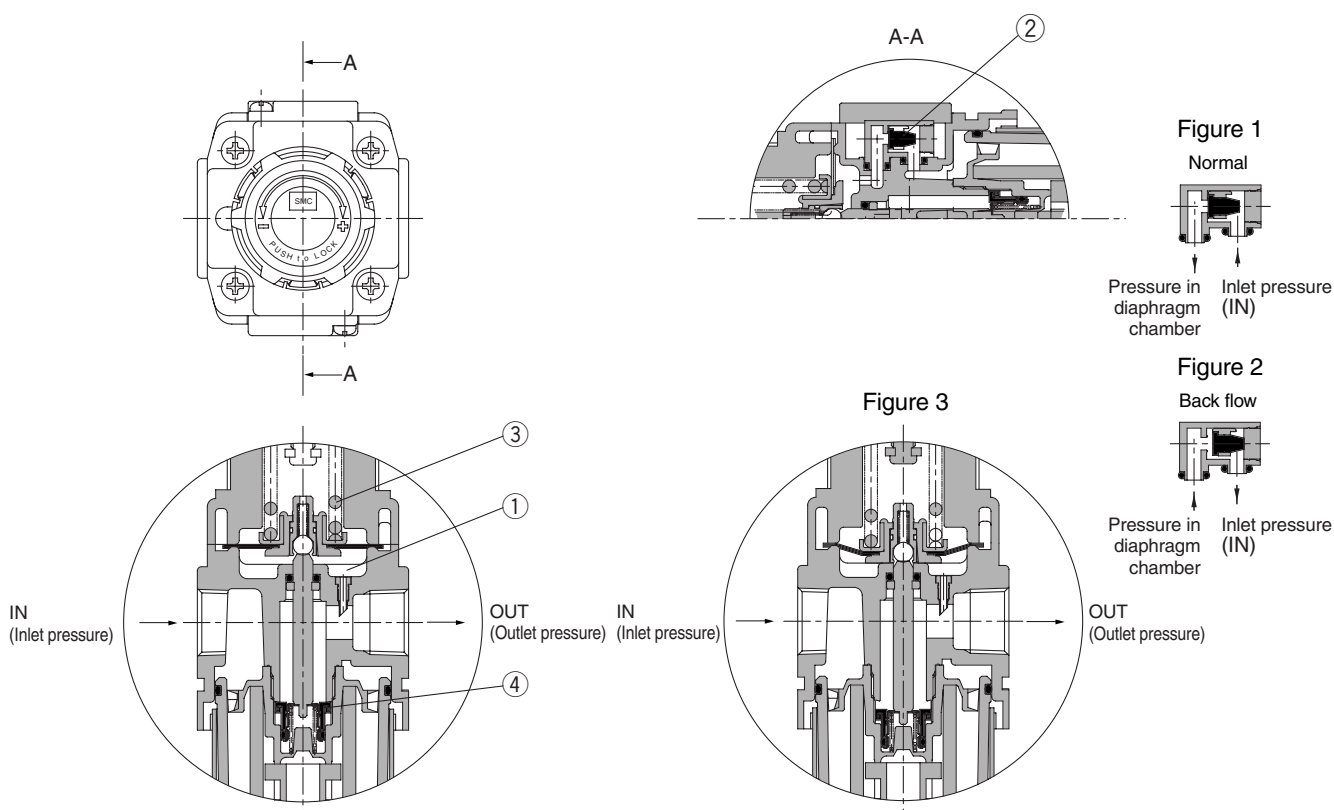

When the inlet pressure (P_1) is higher than the set pressure, the check valve ② closes and operates as a normal regulator (Figure 1).

When the inlet pressure (P_1) is shut off and released, the check valve ②, opens and the pressure in the diaphragm chamber ① is released into the inlet side (Figure 2).

This lowers the pressure in the diaphragm chamber ①, and the force generated by pressure regulator spring ③ lifts the diaphragm. Valve ④ opens through the stem, and the outlet pressure is released to the inlet side (Figure 3).

Construction

AW20K to 40K

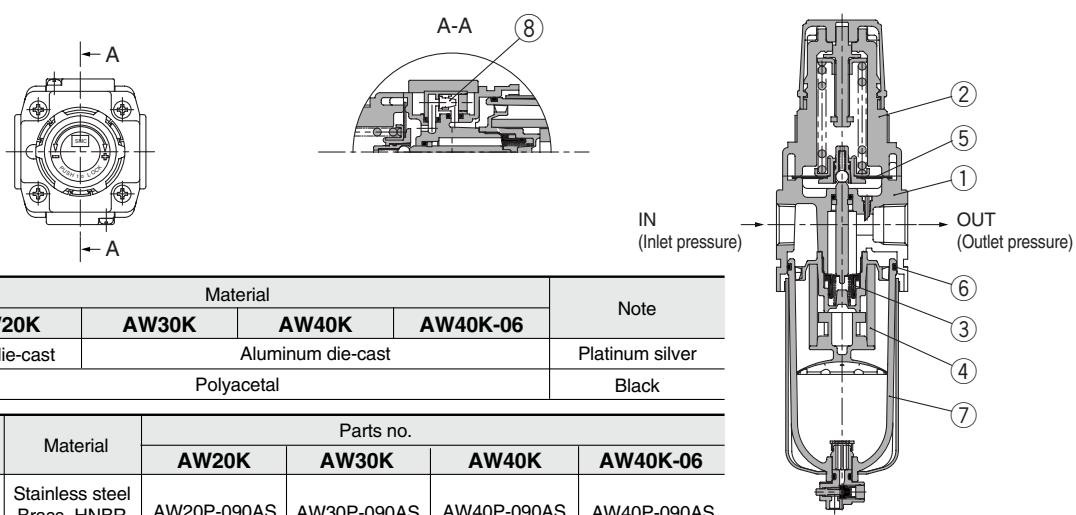

Parts list

No.	Description	Material				Note
		AW20K	AW30K	AW40K	AW40K-06	
1	Body	Zinc die-cast	Aluminum die-cast			Platinum silver
2	Bonnet	Polyacetal				Black
No.	Description	Material	Parts no.			
			AW20K	AW30K	AW40K	AW40K-06
3	Valve assembly	Stainless steel Brass, HNBR	AW20P-090AS	AW30P-090AS	AW40P-090AS	AW40P-090AS
4	Filter element	Non-woven fabric	AF20P-060S	AF30P-060S	AF40P-060S	AF40P-060S
5	Diaphragm assembly	Weatherability NBR	AR20P-150AS	AR30P-150AS	AR40P-150AS	AR40P-150AS
6	Bowl O-ring	NBR	C2SFP-260S	C3SFP-260S	C4SFP-260S	C4SFP-260S
7	Bowl assembly ^{Note 1)}	PC	C2SF	C3SF ^{Note 2)}	C4SF ^{Note 2)}	C4SF ^{Note 2)}
8	Check valve assembly ^{Note 3)}	POM, PBT	AR20KP-020AS	AR20KP-020AS	AR20KP-020AS	AR20KP-020AS

Note 1) Including O-Ring. Contact SMC regarding the bowl assembly supply for PSI and °F unit specifications.

Note 2) Bowl assembly for AW30K to AW60K includes a bowl guard (steel band material).

Note 3) Check valve construction includes the check valve itself, check valve cover, and 2 screws.

Dimensions

AW20K/30K/40K

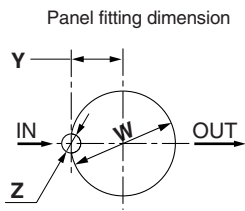
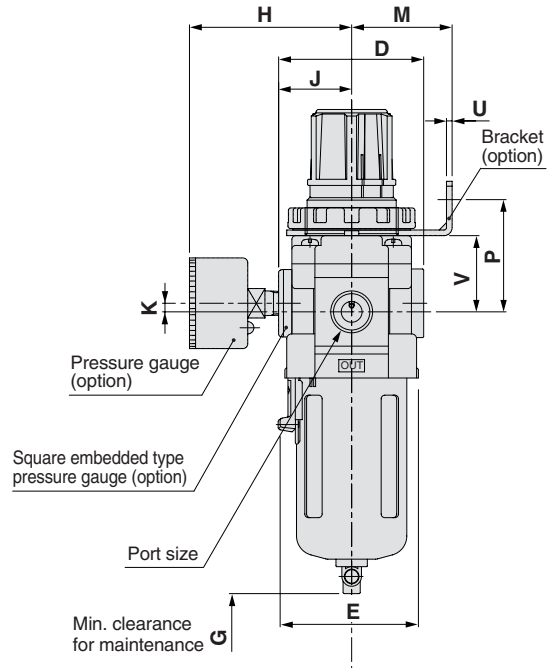
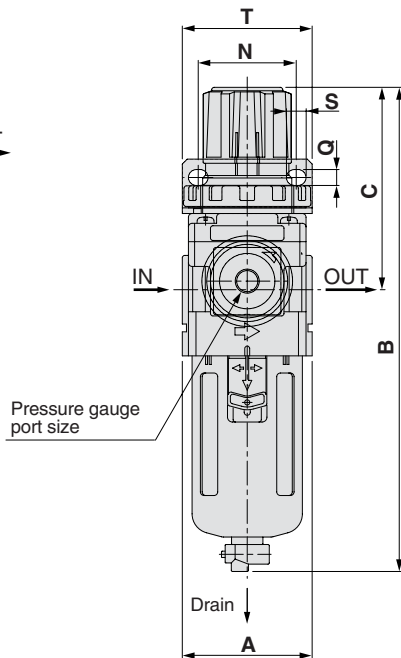

Plate thickness
 AW20K, 30K: Max. 3.5
 AW40K: Max. 5



Applicable model	AW20K		AW30K, AW40K, AC40K-06				
	With auto drain (N.C.)	Metal bowl	With auto drain (N.O./N.C.)	Metal bowl	Metal bowl with level gauge	With drain guide	Drain cock with barb fitting
Optional specifications							

Model	Port size	Standard specification						Accessory specification														
								With pressure gauge				Bracket mounting size					Panel mount				With auto drain	
		A	B	C	D	E	G	H	J	K	M	N	P	Q	S	T	U	V	W	Y	Z	B
AW20K	1/8, 1/4	40	160	73	52	40	40	63	27	5	30	34	44	5.4	15.4	55	2.3	30	28.5	14	6	177
AW30K	1/4, 3/8	53	201	86	59	57	55	66	30.5	3.5	41	40	46	6.5	8	53	2.3	31	38.5	19	7	242
AW40K	1/4, 3/8, 1/2	70	239	92	75	73	80	76	38.5	1.5	50	54	54	8.5	10.5	70	2.3	35.5	42.5	21	7	278
AW40K-06	3/4	75	242	93	75	73	80	76	38.5	1.2	50	54	56	8.5	10.5	70	2.3	37	42.5	21	7	278

Model	Port size	Optional specification			
		With barb fitting	With drain guide	Metal bowl	Metal bowl with level gauge
		B	B	B	B
AW20K	1/8, 1/4	—	—	160	—
AW30K	1/4, 3/8	209	208	214	234
AW40K	1/4, 3/8, 1/2	247	246	251	272
AW40K-06	3/4	250	249	255	275

Mist Separator Regulator

AWM20/30/40

Series AWM is a component made up of a regulator and a mist separator that are integrated to provide optimum results in applications such as clean-air blow operations.



AWM20



AWM40

Symbol

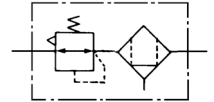

Filtration: 0.3 μ m

How to Order

AWM 30 — F 03 BE — 1N

Mist separator regulator

Body size
20 30 40

Thread type

Nil	Rc
N Note 1)	NPT
F Note 2)	G



Note 1) Drain guide is NPT1/4 (applicable to AWM30 and 40), and the exhaust port for auto drain comes with ϕ 3/8" One-touch fitting (applicable to AWM30 and AWM40).

Note 2) Drain guide is G1/4 (applicable to AWM30 and AWM40).

Port size

Symbol	Port size	Body size		
		20	30	40
01	1/8	●	—	—
02	1/4	●	●	●
03	3/8	—	●	●
04	1/2	—	—	●

Optional specifications

Symbol	Description	Applicable model
1 Note 4)	0.05 to 0.2MPa setting	AWM20 to 40
2	Metal bowl	AWM20 to 40
6	Nylon bowl	AWM20 to 40
8	Metal bowl with level gauge	AWM30, 40
C	With bowl guard	AWM20
J Note 5)	Drain guide 1/4	AWM30, 40
N	Non-relieving	AWM20 to 40
R	Flow direction: Right to left	AWM20 to 40
W	Drain cock with barb fitting: ϕ 6 x ϕ 4 nylon tubing	AWM30, 40
Z Note 6)	Name plate, caution plate for bowl, and pressure gauge in imperial units (PSI, °F)	AWM20 to 40



* When more than one specification is required, indicate in alphanumeric order.
Note 4) The only difference from the standard specifications is the adjusting spring for the regulator. It does not restrict the setting of 0.2MPa or more.
Note 5) Without a valve function.

Accessories Note 3)

Symbol	Description	Applicable model
Nil	—	—
B	With bracket	AWM20 to 40
C	Float type auto drain (N.C.) Note 2)	AWM20 to 40
D	Float type auto drain (N.O.) Note 2)	AWM30, 40
E	With square embedded type pressure gauge (with limit indicator)	AWM20 to 40
G	With round pressure gauge (with limit indicator)	AWM20 to 40
H	With set nut (for panel mount)	AWM20 to 40



Note 1) Optional parts are not assembled and are supplied loose at the time of shipment (except for options C, D and E).
Note 2) Applicable tube O.D for auto drain connection should be ϕ 3/8" in case NPT thread port is chosen.

Note 6) For NPT thread type.
This product is for overseas use only according to the new Measurement Law. (The SI unit type is provided for use in Japan.)

Accessory/Optional specification combinations

⊙: Combination available ⊠: Combination not available
○: Varies depending on the model △: Available only with NPT thread

Combination	Symbol	Accessory						Optional specification							Applicable mist separator regulator				
		B	C	D	E	G	H	1	2	6	8	C	J	N	R	W	Z	AWM20	AWM30 to 40
Accessory/Optional specifications																			
Accessories	With bracket (with set nut)	⊠	⊙	⊙	⊙	⊙	⊙	⊙	⊙	⊙	⊙	⊙	⊙	⊙	⊙	⊙	⊙	⊙	⊙
	Float type auto drain (N.C.)	⊙	⊙	⊙	⊙	⊙	⊙	⊙	⊙	⊙	⊙	⊙	⊙	⊙	⊙	⊙	⊙	⊙	⊙
	Float type auto drain (N.O.)	⊙	⊙	⊙	⊙	⊙	⊙	⊙	⊙	⊙	⊙	⊙	⊙	⊙	⊙	⊙	⊙	⊙	⊙
	Square embedded type pressure gauge	⊙	⊙	⊙	⊙	⊙	⊙	⊙	⊙	⊙	⊙	⊙	⊙	⊙	⊙	⊙	⊙	⊙	⊙
	Round pressure gauge	⊙	⊙	⊙	⊙	⊙	⊙	⊙	⊙	⊙	⊙	⊙	⊙	⊙	⊙	⊙	⊙	⊙	⊙
	With set nut (for panel mount)	⊠	⊙	⊙	⊙	⊙	⊙	⊙	⊙	⊙	⊙	⊙	⊙	⊙	⊙	⊙	⊙	⊙	⊙
Optional specifications	0.05 to 0.2MPa setting	⊙	⊙	⊙	⊙	⊙	⊙	⊙	⊙	⊙	⊙	⊙	⊙	⊙	⊙	⊙	⊙	⊙	⊙
	Metal bowl	⊙	⊙	⊙	⊙	⊙	⊙	⊙	⊙	⊙	⊙	⊙	⊙	⊙	⊙	⊙	⊙	⊙	⊙
	Nylon bowl	⊙	⊙	⊙	⊙	⊙	⊙	⊙	⊙	⊙	⊙	⊙	⊙	⊙	⊙	⊙	⊙	⊙	⊙
	Metal bowl with level gauge	⊙	⊙	⊙	⊙	⊙	⊙	⊙	⊙	⊙	⊙	⊙	⊙	⊙	⊙	⊙	⊙	⊙	⊙
	With bowl guard	⊙	⊙	⊙	⊙	⊙	⊙	⊙	⊙	⊙	⊙	⊙	⊙	⊙	⊙	⊙	⊙	⊙	⊙
	Drain guide 1/4	⊙	⊙	⊙	⊙	⊙	⊙	⊙	⊙	⊙	⊙	⊙	⊙	⊙	⊙	⊙	⊙	⊙	⊙
	Non-relieving type	⊙	⊙	⊙	⊙	⊙	⊙	⊙	⊙	⊙	⊙	⊙	⊙	⊙	⊙	⊙	⊙	⊙	⊙
	Flow direction: Right to left	⊙	⊙	⊙	⊙	⊙	⊙	⊙	⊙	⊙	⊙	⊙	⊙	⊙	⊙	⊙	⊙	⊙	⊙
	Drain cock with barb fitting: ϕ 6 x ϕ 4 nylon tubing	⊙	⊙	⊙	⊙	⊙	⊙	⊙	⊙	⊙	⊙	⊙	⊙	⊙	⊙	⊙	⊙	⊙	⊙
	Name plate, caution plate for bowl, and pressure gauge in imperial units (PSI, °F)	△	△	△	△	△	△	△	△	△	△	△	△	△	△	△	△	△	△

Standard specifications

Model	AWM20	AWM30	AWM40
Port sizes	1/8, 1/4	1/4, 3/8	1/4, 3/8, 1/2
Fluid	Air		
Proof pressure	1.5MPa		
Maximum operating pressure	1.0MPa		
Set pressure range	0.05 to 0.85MPa		
Pressure gauge port size ^{Note 1)}	Rc, NPT, G 1/8	Rc, NPT, G 1/8	Rc, NPT, G 1/4
Ambient and fluid temperature	-5 to 60°C (with no freezing)		
Nominal filtration rating	0.3µm (95% filtered particle size)		
Outlet side oil mist concentration	Max. 1.0mg/m ³ (ANR) (approx. 0.8ppm) ^{Note 2) Note 3)}		
Rated flow L/min (ANR) ^{Note 4)}	150	330	820
Bowl material	Polycarbonate		
Bowl guard	Option	Standard	
Drain capacity (cm ³)	8	25	45
Construction	Relieving type		
Weight (kg)	0.44	0.59	1.25

Note) When "N" is specified in the end of part number of auto drain, applicable tube O.D should be ø3/8".



Note 1) Pressure gauge connection threads are not required for the regulator with a square embedded type pressure gauge (AWM20 to 40).

Note 2) When the compressor oil mist discharge concentration is 30^{mg}/Nm³ (ANR).

Note 3) Bowl O-ring and other O-rings are slightly lubricated.

Note 4) When the outlet pressure is 0.5MPa. (The rated flow varies depending on the set pressure.)

Keep the air flow within the rated flow to prevent and outflow of a lubricant to the outlet side.

Accessory part no.

Accessory		Applicable model	AWM20	AWM30	AWM40
Bracket assembly ^{Note 1)}			AW20P-270AS	AR30P-270AS	AR40P-270AS
Set nut			AR20P-260S	AR30P-260S	AR40P-260S
Pressure gauge ^{Note 2)}	1.0MPa	Round	G36-10-□01	G36-10-□01	G46-10-□02
		Square embedded type ^{Note 3)}	GC3-10AS	GC3-10AS	GC3-10AS
	0.2MPa	Round	G36-2-□01	G36-2-□01	G46-2-□02
		Square embedded type ^{Note 3)}	GC3-2AS	GC3-2AS	GC3-2AS
Float type auto drain ^{Note 4)}	N.O.	—	AD38	AD38N ^{Note)}	AD48
	N.C.	AD27	AD37	AD37N ^{Note)}	AD47

Note) When "N" is specified in the end of part number of auto drain, applicable tube O.D should be ø3/8".



Note 1) Assembly includes a bracket and set nuts.

Note 2) □ in part numbers for a round pressure gauge indicates a type of connection thread. No indication is necessary for R; however, indicate N for NPT. Contact SMC regarding the NPT connection thread and pressure gauge supply for PSI unit specifications.

Note 3) Includes one O-ring and 2 mounting screws.

Note 4) Minimum operating pressure: N.O. type—0.1MPa; N.C. type—0.1MPa (AD27) and 0.15MPa (AD37/47). Set the pressure to allow a pressure drop when the fluid flows. Contact SMC regarding the specifications for PSI unit and "F".

⚠ Specific Product Precautions

Be sure to read before handling. Refer to pages 75 through 78 for safety instructions and F.R.L. unit precautions.

Selection

⚠ Warning

- Residual pressure release (outlet pressure release) is not complete by releasing inlet pressure. Contact SMC regarding residual pressure release.

Air Supply

⚠ Caution

- Install an air filter (Series AF) as a preliminary filter on the inlet side of the mist separator regulator to prevent premature clogging.

Maintenance

⚠ Warning

- Replace the element every 2 years or when the pressure drop becomes 0.1MPa, whichever comes first, to prevent damage to the element.

Mounting & Adjustment

⚠ Warning

- Set the regulator while checking the displayed values of the inlet and outlet pressure gauges. Turning the knob excessively can cause damage to the internal parts.
- The pressure gauge included with mist separator regulators for 0.05 to 0.2MPa setting is for up to 0.2MPa only. Exceeding 0.2MPa of pressure can damage the gauge.
- Do not use tools on the pressure regulator knob as this may cause damage. It must be operated manually.

⚠ Caution

- Be sure to unlock the knob before adjusting the pressure and lock it after setting the pressure. Failure to follow this procedure can cause damage to the knob and the outlet pressure may fluctuate.

- Pull the pressure regulator knob to unlock. (You can visually verify this with the "orange mark" that appears in the gap.)
- Push the pressure regulator knob to lock. When the knob is not easily locked, turn it left and right a little and then push it (when the knob is locked, the "orange mark" i.e., the gap, will disappear).



- A knob cover is available to prevent careless operation of the knob. Refer to Features 1 for details.

AWM20/30/40

Flow Characteristics (Representative values)

Condition: Inlet pressure 0.7MPa

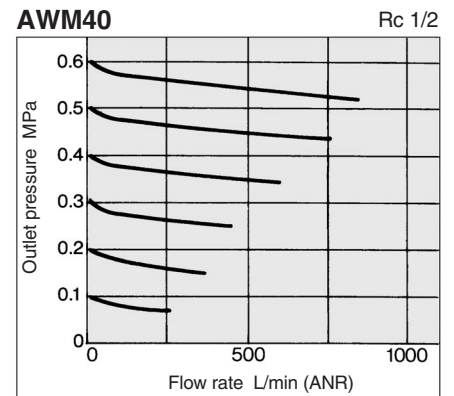
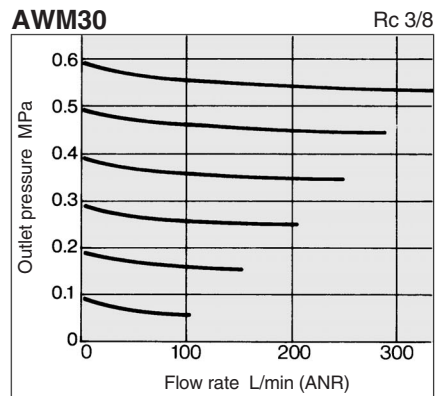
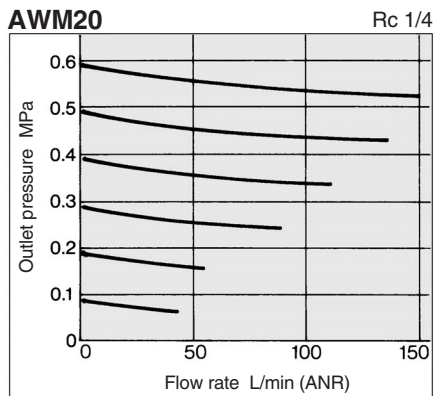

Pressure Characteristics

Conditions: Inlet pressure 0.7MPa; Outlet pressure 0.2MPa; Flow rate: 20L/min (ANR)

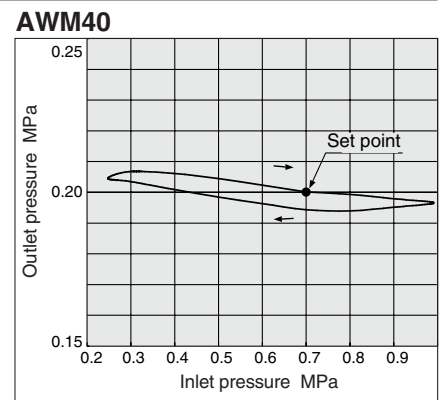
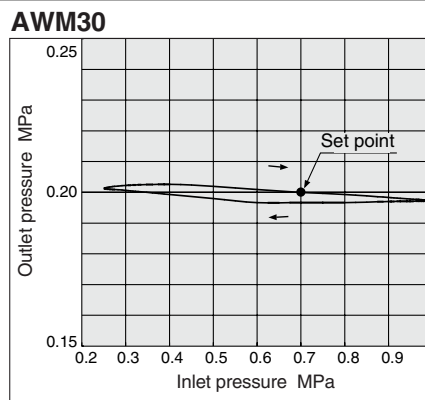
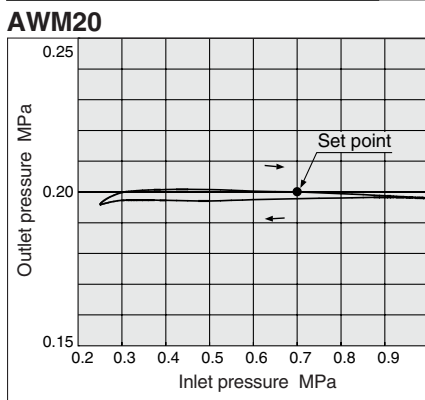

Construction

JIS symbol

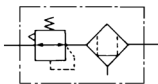

AWM20

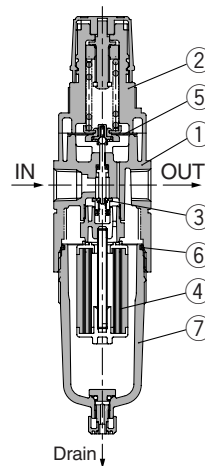

AWM30, 40

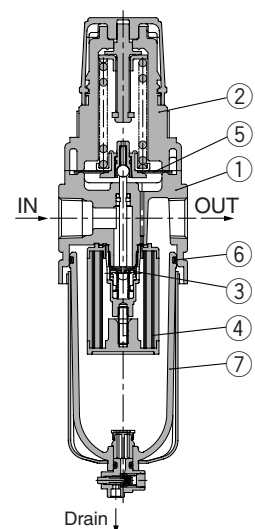

Parts list

No.	Description	Material			Note
		AWM20	AWM30	AWM40	
1	Body	Zinc die-cast	Aluminum die-cast		Platinum silver
2	Bonnet		Polyacetal		Black

Replacement parts

No.	Description	Material	Part no.		
			AWM20	AWM30	AWM40
3	Valve assembly	Brass, HNBR	AWM20P-090AS	AWM30P-090AS	AWM40P-090AS
4	Element assembly	—	AFM20P-060AS	AFM30P-060AS	AF40P-060AS
5	Diaphragm assembly	Weatherability NBR	AR20P-150AS	AR30P-150AS	AR40P-150AS
6	Bowl O-ring	NBR	C2SFP-260S	C3SFP-260S	C4SFP-260S
7	Bowl assembly ^{Note 1)}	PC	C2SF	C3SF ^{Note 2)}	C4SF ^{Note 2)}



Note 1) Including O-Ring. Contact SMC regarding the bowl assembly supply for PSI and °F unit specifications.
 Note 2) Bowl assembly for AWM30 and AWM40 comes with a bowl guard (steel band material).

Mist Separator Regulator **AWM20/30/40**

Dimensions

AWM20

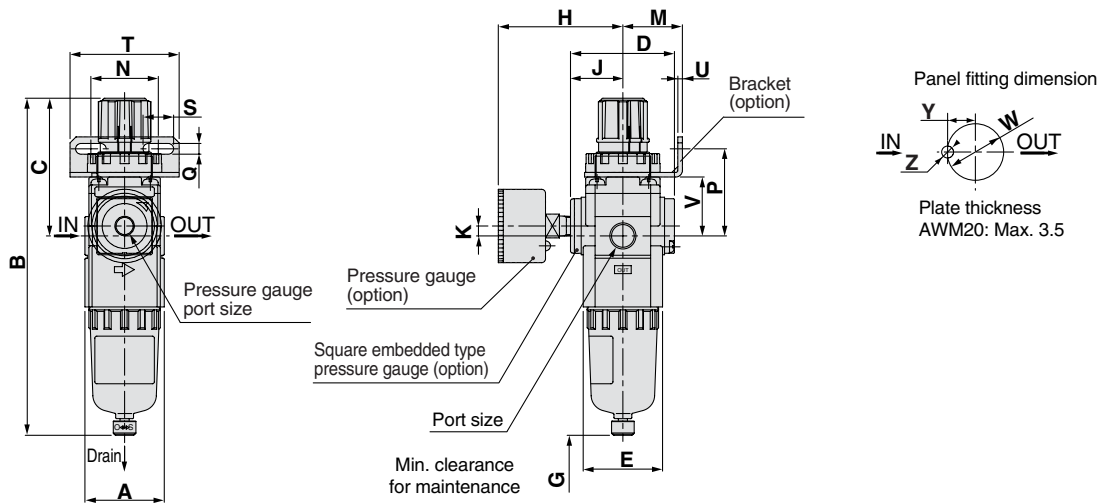

AWM30, 40

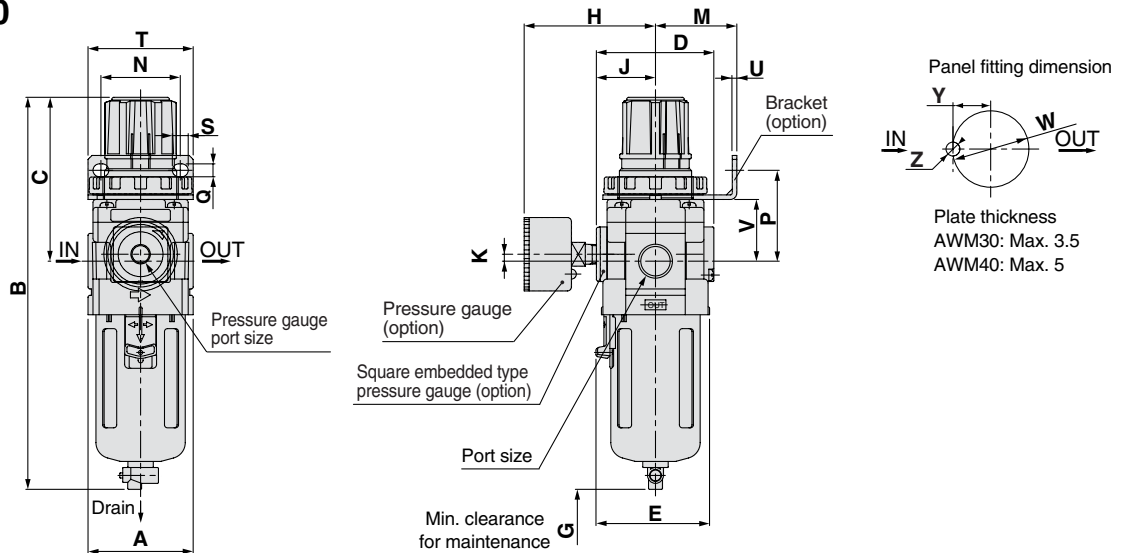

Applicable model	AWM20		AWM30, AWM40				
Optional specifications	With auto drain (N.C.)	Metal bowl	With auto drain (N.O./N.C.)	Metal bowl	Metal bowl with level gauge	With drain guide	Drain cock with barb fitting

Model	Port size	Standard specification						Accessory specification														
		A	B	C	D	E	G	With pressure gauge			Bracket mounting size					Panel mount					With auto drain	
		A	B	C	D	E	G	H	J	K	M	N	P	Q	S	T	U	V	W	Y	Z	B
AWM20	1/8, 1/4	40	173	73	52	40	45	63	27	5	30	34	44	5.4	15.4	55	2.3	30	28.5	14	6	190
AWM30	1/4, 3/8	53	201	86	59	57	50	66	30.5	3.5	41	40	46	6.5	8	53	2.3	31	38.5	19	7	242
AWM40	1/4, 3/8, 1/2	70	239	92	75	73	70	76	38.5	1.5	50	54	54	8.5	10.5	70	2.3	35.5	42.5	21	7	278

Model	Optional specification				
	With barb fitting	With drain guide	Metal bowl	Metal bowl with level gauge	
		B	B	B	B
AWM20	—	—	173	—	
AWM30	209	208	214	234	
AWM40	247	246	252	272	

Micro-Mist Separator Regulator AWD20/30/40

Series AWD is a component made up of a regulator and a micro-mist separator that are integrated to provide optimum results in applications such as ultraclean air blow operations.

Filtration: 0.01µm



AWD20



AWD40

Symbol

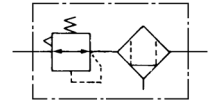

How to Order

AWD 30 — F 03 BE — 1N

Micro-mist separator regulator

Body size

20	30	40
----	----	----

Thread type

Nil	Rc
N Note 1)	NPT
F Note 2)	G



Note 1) Drain guide is for NPT1/4 (applicable to AWD30 and AWD40), and the exhaust port for auto drain comes with ø3/8" One-touch fitting (applicable to AWD30 and AWD40).

Note 2) Drain guide is G1/4 (applicable to AWD30 and AWD40).

Port size

Symbol	Port size	Body size		
		20	30	40
01	1/8	●	—	—
02	1/4	●	●	●
03	3/8	—	●	●
04	2/1	—	—	●

Optional specifications

Symbol	Description	Applicable model
1 Note 4)	0.05 to 0.2MPa setting	AWD20 to 40
2	Metal bowl	AWD20 to 40
6	Nylon bowl	AWD20 to 40
8	Metal bowl with level gauge	AWD30, 40
C	With bowl guard	AWD20
J Note 5)	Drain guide 1/4	AWD30, 40
N	Non-relieving	AWD20 to 40
R	Flow direction: Right to left	AWD20 to 40
W	Drain cock with barb fitting: ø6 x ø4 nylon tubing	AWD30, 40
Z Note 6)	Name plate, caution plate for bowl, and pressure gauge in imperial units (PSI, °F)	AWD20 to 40



* When more than one specification is required, indicate in alphanumeric order.

Note 4) The only difference from the standard specifications is the adjusting spring for the regulator. It does not restrict the setting of 0.2MPa or more.

Note 5) Without a valve function.

Note 6) For NPT thread type.

This product is for overseas use only according to the new Measurement Law. (The SI unit type is provided for use in Japan.)

Accessories Note 3)

Symbol	Description	Applicable model
Nil	—	—
B	With bracket	AWD20 to 40
C	Float type auto drain (N.C.) Note 4)	AWD20 to 40
D	Float type auto drain (N.O.) Note 4)	AWD30, 40
E	With square embedded type pressure gauge (with limit indicator)	AWD20 to 40
G	With round pressure gauge (with limit indicator)	AWD20 to 40
H	With set nut (for panel mount)	AWD20 to 40



Note 3) Optional parts are not assembled and are supplied loose at the time of shipment (except for options C, D and E).
Note 4) Applicable tube O.D for auto drain connection should be ø3/8" in case NPT thread port is chosen.

Accessory/Optional specification combinations

⊙: Combination available

□: Combination not available

○: Varies depending on the model

△: Available only with NPT thread

Combination	Symbol	Accessory										Optional specification							Applicable micro-mist separator regulator	
		B	C	D	E	G	H	1	2	6	8	C	J	N	R	W	Z	AWD20	AWD30 to 40	
Accessories	With bracket (with set nut)	□	⊙	○	⊙	⊙	□	⊙	⊙	⊙	○	○	⊙	⊙	○	△	⊙	⊙		
	Float type auto drain (N.C.)	⊙	□	□	⊙	⊙	⊙	⊙	⊙	○	□	⊙	⊙	□	△	⊙	⊙			
	Float type auto drain (N.O.)	⊙	□	□	⊙	⊙	⊙	⊙	⊙	○	□	⊙	⊙	□	△	□	⊙			
	Square embedded type pressure gauge	⊙	⊙	⊙	□	□	⊙	⊙	⊙	○	○	⊙	⊙	○	△	⊙	⊙			
	Round pressure gauge	⊙	⊙	○	□	□	⊙	⊙	⊙	○	○	⊙	⊙	○	△	⊙	⊙			
	Panel mount (with set nut)	□	⊙	○	⊙	⊙	□	⊙	⊙	○	○	⊙	⊙	○	△	⊙	⊙			
Optional specifications	0.05 to 0.2MPa setting	⊙	⊙	○	⊙	⊙	□	⊙	⊙	○	○	⊙	⊙	○	△	⊙	⊙			
	Metal bowl	⊙	⊙	○	⊙	⊙	⊙	□	□	□	□	⊙	⊙	□	△	⊙	⊙			
	Nylon bowl	⊙	⊙	○	⊙	⊙	⊙	□	□	□	○	⊙	⊙	○	△	⊙	⊙			
	Metal bowl with level gauge	⊙	⊙	○	⊙	⊙	⊙	□	□	□	□	⊙	⊙	□	△	□	⊙			
	With bowl guard	⊙	⊙	□	⊙	⊙	⊙	□	□	□	□	⊙	⊙	□	△	⊙	□			
	Drain guide 1/4	⊙	□	□	⊙	⊙	⊙	⊙	⊙	⊙	□	⊙	⊙	□	△	□	⊙			
	Non-relieving type	⊙	⊙	○	⊙	⊙	⊙	⊙	⊙	○	○	⊙	⊙	○	△	⊙	⊙			
	Flow direction: Right to left	⊙	⊙	○	⊙	⊙	⊙	⊙	⊙	○	○	⊙	⊙	○	△	⊙	⊙			
	Drain cock with barb fitting: ø6 x ø4 nylon tubing	⊙	□	□	⊙	⊙	⊙	⊙	⊙	⊙	□	□	⊙	⊙	△	□	⊙			
Name plate, caution plate for bowl, and pressure gauge in imperial units (PSI, °F)	△	△	△	△	△	△	△	△	△	△	△	△	△	△	△	△				

Standard specifications

Model	AWD20	AWD30	AWD40
Port sizes	1/8, 1/4	1/4, 3/8	1/4, 3/8, 1/2
Fluid	Air		
Proof pressure	1.5MPa		
Maximum operating pressure	1.0MPa		
Set pressure range	0.05 to 0.85MPa		
Pressure gauge port size ^{Note 1)}	Rc, NPT, G 1/8	Rc, NPT, G 1/8	Rc, NPT, G 1/4
Ambient and fluid temperature	-5 to 60°C (with no freezing)		
Nominal filtration rating	0.01µm (95% filtered particle size)		
Outlet side oil mist concentration	Max. 0.1mg/m ³ (ANR) ^{Note 2) Note 3)} (before saturated with hydraulic fluid: 0.01mg/m ³ (ANR) or less, approx. 0.008ppm)		
Rated flow L/min (ANR) ^{Note 4)}	90	180	450
Bowl material	Polycarbonate		
Bowl guard	Option	Standard	
Drain capacity (cm ³)	8	25	45
Construction	Relieving type		
Weight (kg)	0.44	0.59	1.25



Note 1) Pressure gauge connection threads are not required for the regulator with a square embedded type pressure gauge (AWD20 to 40).

Note 2) When the compressor oil mist discharge concentration is 30mg/m³ (ANR).

Note 3) Bowl O-ring and other O-rings are slightly lubricated.

Note 4) When the outlet pressure is 0.5MPa. (The rated flow varies depending on the set pressure.)
Keep the air flow within the rated flow to prevent an outflow of lubricant to the outlet side.

Accessory part no.

Applicable model		AWD20	AWD30	AWD40	
Accessory					
Bracket assembly ^{Note 1)}		AW20P-270AS	AR30P-270AS	AR40P-270AS	
Set nut		AR20P-260S	AR30P-260S	AR40P-260S	
Pressure gauge ^{Note 2)}	1.0MPa	Round	G36-10-□01	G36-10-□01	G46-10-□02
		Square embedded type ^{Note 3)}	GC3-10AS	GC3-10AS	GC3-10AS
	0.2MPa	Round	G36-2-□01	G36-2-□01	G46-2-□02
		Square embedded type ^{Note 3)}	GC3-2AS	GC3-2AS	GC3-2AS
Float type auto drain ^{Note 4)}	N.O.	—	AD38 AD38N ^{Note 5)}	AD48 AD48N ^{Note 5)}	
	N.C.	AD27	AD37 AD37N ^{Note 5)}	AD47 AD47N ^{Note 5)}	



Note 1) Assembly includes a bracket and set nuts.

Note 2) □ in part numbers for a round pressure gauge indicates a type of connection thread. No indication is necessary for R; however, indicate N for NPT. Contact SMC regarding the NPT connection thread and pressure gauge supply for PSI unit specifications.

Note 3) Includes one O-ring and 2 mounting screws.

Note 4) Minimum operating pressure: N.O. type-0.1MPa; N.C. type-0.1MPa (AD27) and 0.15MPa (AD37/47). Set the pressure to allow a pressure drop when the fluid flows. Contact SMC regarding the specifications for PSI unit and "F".

Note 5) When "N" is specified in the end of part number of auto drain, applicable tube O.D should be ø3/8".

⚠ Specific Product Precautions

Be sure to read before handling. Refer to pages 75 through 78 for safety instructions, F.R.L. unit precautions.

Selection

⚠ Warning

- Residual pressure release (outlet pressure release) is not complete by releasing inlet pressure. Contact SMC regarding the residual pressure release.

Air Supply

⚠ Caution

- Install an air filter (Series AFM) as a preliminary filter on the inlet side of the micro-mist separator to prevent premature clogging.

Maintenance

⚠ Warning

- Replace the element every 2 years or when the pressure drop becomes 0.1MPa, whichever comes first, to prevent damage to the element.

Mounting & Adjustment

⚠ Warning

- Set the regulator while checking the displayed values of the inlet and outlet pressure gauges. Turning the knob excessively can cause damage to the internal parts.
- The pressure gauge included with micro-mist separator regulator for 0.05 to 0.2MPa setting is for up to 0.2MPa only. Exceeding 0.2MPa of pressure can damage the gauge.
- Do not use tools on the pressure regulator knob as this may cause damage. It must be operated manually.

⚠ Caution

- Be sure to unlock the knob before adjusting the pressure and lock it after setting the pressure.
Failure to follow this procedure can cause damage to the knob and the outlet pressure may fluctuate.

- Pull the pressure regulator knob to unlock. (You can visually verify this with the "orange mark" that appears in the gap.)
- Push the pressure regulator knob to lock. When the knob is not easily locked, turn it left and right a little and then push it (when the knob is locked, the "orange mark" will disappear).



- A knob cover is available to prevent careless operation of the knob. Refer to Features 1 for details.

AWD20/30/40

Flow Characteristics (Representative value)

Condition: Inlet pressure 0.7MPa

AWD20 Rc 1/4

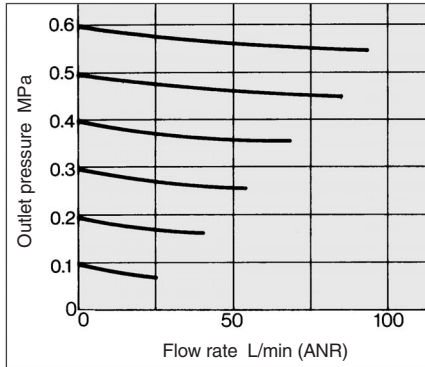

AWD30 Rc 3/8

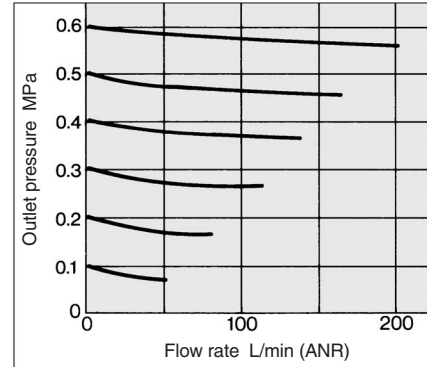

AWD40 Rc 1/2

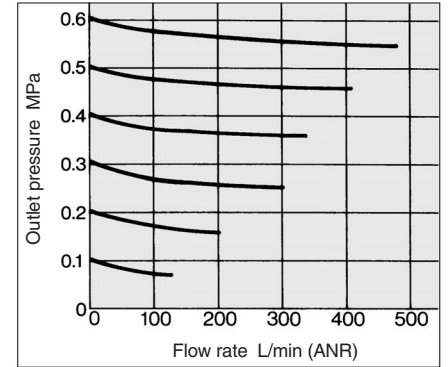

Pressure Characteristics (Representative value)

Conditions: Inlet pressure 0.7MPa; Outlet pressure 0.2MPa; Flow rate: 20L/min (ANR)

AWD20

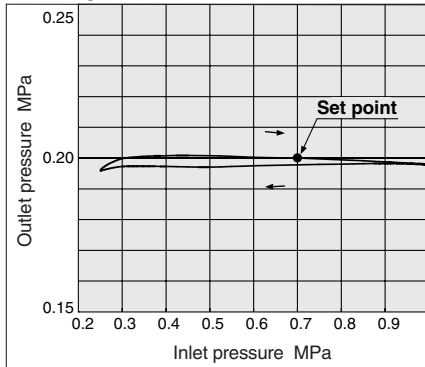

AWD30

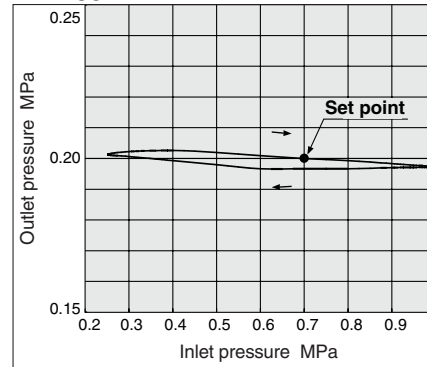

AWD40

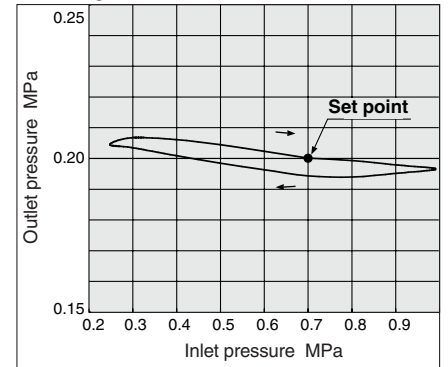

Construction

JIS symbol

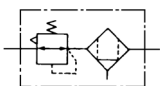

AWD20

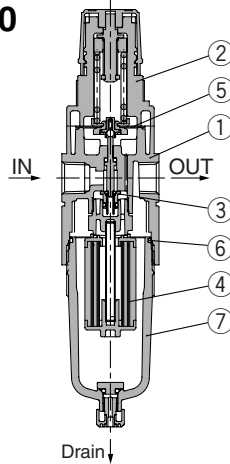

AWD30, 40

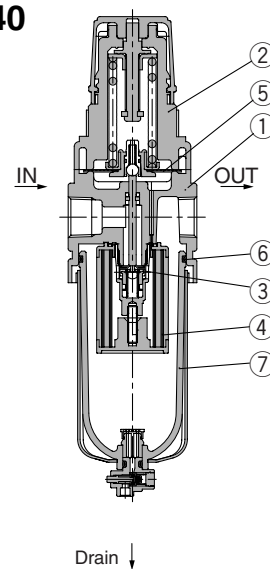

Parts list

No.	Description	Material			Note
		AWD20	AWD30	AWD40	
1	Body	Zinc die-cast	Aluminum die-cast		Platinum silver
2	Bonnet	Polyacetal			Black

Replacement parts

No.	Description	Materials	Parts no.		
			AWD20	AWD30	AWD40
3	Valve assembly	Brass, HNBR	AWM20P-090AS	AWM30P-090AS	AWM40P-090AS
4	Element assembly	—	AFD20P-060AS	AFD30P-060AS	AFD40P-060AS
5	Diaphragm assembly	Weatherability NBR	AR20P-150AS	AR30P-150AS	AR40P-150AS
6	Bowl O-ring	NBR	C2SFP-260S	C3SFP-260S	C4SFP-260S
7	Bowl assembly ^{Note 1)}	PC	C2SF	C3SF ^{Note 2)}	C4SF ^{Note 2)}

Note 1) Including O-Ring. Contact SMC regarding the bowl assembly supply for PSI and °F unit specifications.
 Note 2) Bowl assembly for AWD30 and AWD40 comes with a bowl guard (steel band material).

Dimensions

AWD20

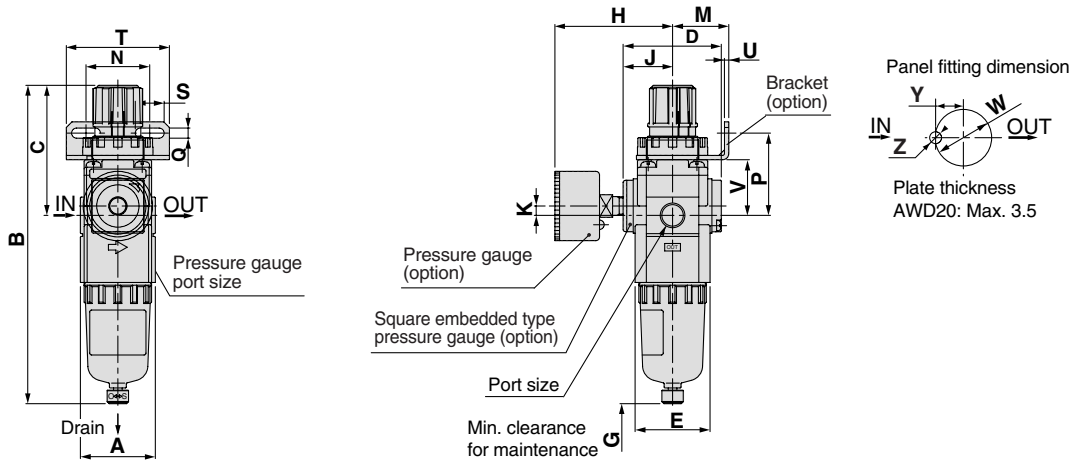

AWD30, 40

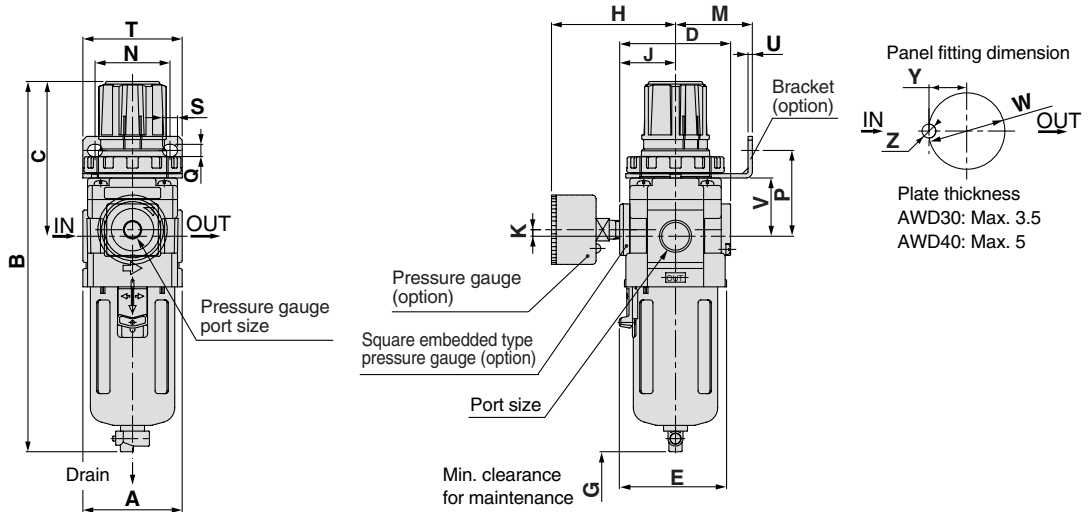

Applicable model	AFD20		AWD30, AWD40				
	With auto drain (N.C.)	Metal bowl	With auto drain (N.O./N.C.)	Metal bowl	Metal bowl with level gauge	With drain guide	Drain cock with barb fitting
Optional specifications	 M5 x 0.8		 N.O.: Black N.C.: Gray ø10 One-touch fitting			 Width across flats 17	 Barb fitting Applicable tubing: T0604

Model	Port size	Standard specification						Accessory specification														
		A	B	C	D	E	G	With pressure gauge			Bracket mounting size						Panel mount				With auto drain	
								H	J	K	M	N	P	Q	S	T	U	V	W	Y		Z
AWD20	1/8, 1/4	40	173	73	52	40	45	63	27	5	30	34	44	5.4	15.4	55	2.3	30	28.5	14	6	190
AWD30	1/4, 3/8	53	201	86	59	57	50	66	30.5	3.5	41	40	46	6.5	8	53	2.3	31	38.5	19	7	242
AWD40	1/4, 3/8, 1/2	70	239	92	75	73	70	76	38.5	1.5	50	54	54	8.5	10.5	70	2.3	35.5	42.5	21	7	278

Model	Optional specification			
	With barb fitting	With drain guide	Metal bowl	Metal bowl with level gauge
	B	B	B	B
AWD20	—	—	173	—
AWD30	209	208	214	234
AWD40	247	246	252	272



Safety Instructions

These safety instructions are intended to prevent a hazardous situation and/or equipment damage. These instructions indicate the level of potential hazard by a label of "**Caution**", "**Warning**", or "**Danger**". To ensure safety, be sure to observe ISO 4414 Note 1), JIS B 8370 Note 2) and other safety practices.

⚠ Caution: Operator error could result in injury or equipment damage.

⚠ Warning: Operator error could result in serious injury or loss of life.

⚠ Danger : In extreme conditions, there is a possible result of serious injury or loss of life.

Note 1) ISO 4414: Pneumatic fluid power – General Rules relating to systems.

Note 2) JIS B 8370: Pneumatic system axiom

⚠ Warning

1. The compatibility of pneumatic equipment is the responsibility of the person who designs the pneumatic system or decides its specifications.

Since the products specified here are used in various operating conditions, their compatibility for the specific pneumatic system must be based on specifications or after analysis and/or tests to meet your specific requirements. The expected performance and safety assurance will be the responsibility of the person who has determined the compatibility of the system. This person should continuously review the suitability of all items specified, referring to the latest catalog information with a view to giving due consideration to any possibility of equipment failure when configuring a system.

2. Only trained personnel should operate pneumatically operated machinery and equipment.

Compressed air can be dangerous if handled incorrectly. Assembly, handling or repair of pneumatic systems should be performed by trained and experienced operators.

3. Do not service machinery/equipment or attempt to remove components until safety is confirmed.

1. Inspection and maintenance of machinery/equipment should only be performed after confirmation of safe locked-out control positions.
2. When equipment is to be removed, confirm the safety process as mentioned above. Cut the supply pressure for this equipment and exhaust all residual compressed air in the system.
3. Before machinery/equipment is restarted, take measures to prevent shooting-out of cylinder piston rod, etc.

4. Contact SMC if the product is to be used in any of the following conditions:

1. Conditions and environments beyond the given specifications, or if product is used outdoors.
2. Installation on equipment in conjunction with atomic energy, railway, air navigation, vehicles, medical equipment, food and beverages, recreation equipment, emergency stop circuits, press applications, or safety equipment.
3. An application which has the possibility of having negative effects on people, property, or animals, requiring special safety analysis.



F.R.L. Unit Precautions 1

Be sure to read before handling.

Design

⚠ Warning

1. The standard bowl for the air filter, filter regulator, and lubricator, as well as the sight dome for the lubricator are made of polycarbonate. Do not use in an environment where they are exposed to or come in contact with organic solvents, chemicals, cutting oil, synthetic oil, alkali, and thread lock solutions.
2. Avoid applications where pressurized air is frequently introduced to and released from the standard bowl of an air filter, filter regulator, or lubricator. It may cause the bowl to be damaged. Use of a metal bowl is recommended for such applications.
3. Consult with SMC if the intended application calls for absolutely zero leakage due to special atmospheric requirements, or if the use of a fluid other than air is required.

4. Regulator and filter regulator

Be sure to install a safety device to prevent damage or malfunction of the outlet side components when the output pressure exceeds the set pressure value.

⚠ Caution

1. Select a model that is suitable for the desired purity by referring to the SMC's Best Pneumatics catalog.
2. Components cannot be used for applications that are outside the range of specifications. Consult with SMC when you anticipate using the component outside the range of its specifications (such as temperature and pressure).

3. Mist separator and micro-mist separator

Design the system so that the mist separator and micro-mist separator are installed where there is less pulsation. A pressure difference between internal and external pressure inside the element should be kept within 0.1MPa, as exceeding this value can cause damage.

4. Regulator and filter regulator

Air consumption is 0.1L/min (ANR) or less under standard specifications. Consult with SMC, if this value is not allowable.

5. F.R.L.

1. When using a 2-unit combination such as AC□0A, AC□0B, and AC□0D, secure the top and bottom of the bracket. For 3-unit, securing the bottom side of the bracket is recommended.
2. The bracket position varies depending on the attachment (T-interface or pressure switch) mounting.
3. The standard mounting position for bracket is OUT side of each component (AF, AR, AL, AW, AFM, and AKM). Refer to the table on page 19 for pitches and dimensions of the bracket when mounting the attachment.
4. Brackets cannot be mounted on both sides of a T-interface or pressure switch.
5. Contact SMC if your wish to change the bracket mounting position.

Selection

⚠ Warning

1. The mineral grease used on internal sliding parts and seals may run down to outlet side components. Consult with SMC if this is not desirable.

2. Regulator and filter regulator

1. Residual pressure release (outlet pressure release) is not complete by releasing the inlet pressure. To release residual pressure, select a model with a back flow mechanism. Using a model without a back flow mechanism makes for inconsistent residual pressure release (i.e., residual pressure may or may not be released) depending upon the operating conditions.
2. Contact SMC if air will not be consumed in the system for a long period of time, or if the outlet side will be used with a sealed circuit and a balanced circuit, as this may cause the set pressure of the outlet side to fluctuate.
3. Set the regulating pressure range for the outlet pressure of the regulator in a range that is 85% or less of the inlet pressure. If set to above 85%, the outlet pressure will be easily affected by fluctuations in the flow rate and inlet pressure, and become unstable.
4. A safety margin is calculated into the maximum regulating pressure range appearing in the catalog's specification table. However, the outlet pressure may exceed the set pressure due to a delay in the valve's closing.
5. Contact SMC when a circuit requires the use of a regulator having relief sensitivity with high precision and setting accuracy.

3. Lubricator

1. Contact SMC when the lubricator is used in high frequency operations, such as in a press.
2. Lubrication cannot be properly performed if the operating flow rate is too low. Select proper size lubricator by referring the minimum dripping flow rate provided in this catalog.
3. Avoid the use of a lubricator that causes back flow as this may cause damage to internal parts.
4. Use a check valve (Series AKM) to prevent the lubricant from back flowing when redirecting the piping on the inlet side.

4. Float-type auto drain

Use auto drain under the following conditions to avoid malfunction.

<N.O. type>

- Operating compressor: 0.75KW (100L/min (ANR)) or more
When using 2 or more auto drains, multiply the above value by the number of auto drains to find the capacity of the compressors you will need.

For example, when using 2 auto drains, 1.5kW (200L/min (ANR)) of the compressor capacity is required.

- Operating pressure: 0.1MPa or more

<N.C. type>

- Operating pressure for AD17, AD27: 0.1MPa or more
- Operating pressure for AD37, AD47: 0.15MPa or more



F.R.L. Unit Precautions 2

Be sure to read before handling.

Mounting

⚠ Caution

1. To avoid reversed connections of the air inlet/outlet, make connections after confirming the "IN/OUT" mark or arrows that indicate the direction of air flow. Reversed connections can cause malfunction.
2. Components with a bowl, e.g., air filter, filter regulator, lubricator, must be installed vertically with the bowl downward so that faulty drain discharge and dripping can be verified.
3. Ensure sufficient top, bottom, and front clearance for maintenance and operation of each component. Refer to the dimensions section for the minimum clearance for each component.

4. Regulator and filter regulators

Be sure to unlock the knob before adjusting the pressure and to lock it after the pressure is set.

Adjustment

⚠ Warning

1. Regulator and filter regulator

1. Set the regulator while verifying the displayed values of the inlet and outlet pressure gauges. Turning the knob excessively can cause damage to the internal parts.
2. Do not use a tool on the pressure regulator knob as this can cause damage. It must be operated manually.

⚠ Caution

1. Regulator and filter regulator

1. Be sure to check the inlet pressure before setting the outlet pressure.
2. The pressure gauge included with regulators for 0.02 to 0.2MPa setting is for up to 0.2MPa only. Do not apply pressure exceeding 0.2 MPa. It can damage the pressure gauge.
3. To set the pressure using the knob, turn the knob in the direction that increases pressure and lock the knob after the pressure is set. If this is done in the direction that decreases pressure, the pressure may drop from the original set pressure. Turning the knob clockwise increases the outlet pressure, and turning it counterclockwise reduces the pressure.

Piping

⚠ Warning

1. To screw piping materials into components, tighten with a recommended tightening torque while holding the female thread side. If the minimum tightening torque is not observed, this can cause a looseness and seal failure. On the other hand, excess tightening torque can cause damage to the threads. Furthermore, tightening without holding the female thread side can cause damage due to the excess force that is applied directly to the piping bracket.

Recommended tightening torque

Unit: N·m

Connection thread	M5	1/8	1/4	3/8	1/2	3/4	1
Torque	*	7 to 9	12 to 14	22 to 24	28 to 30	28 to 30	36 to 38

- * After tightening by hand, tighten further approximately 1/6 turn using a tightening tool.

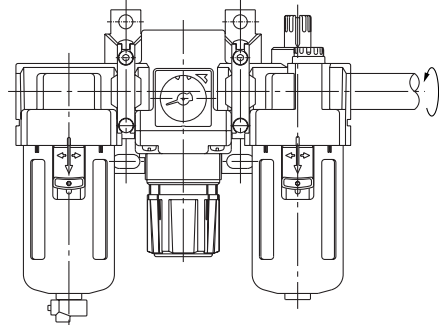

2. Avoid excessive torsional moment or bending moment other than those caused by the equipment's own weight as this can cause damage. Support external piping separately.

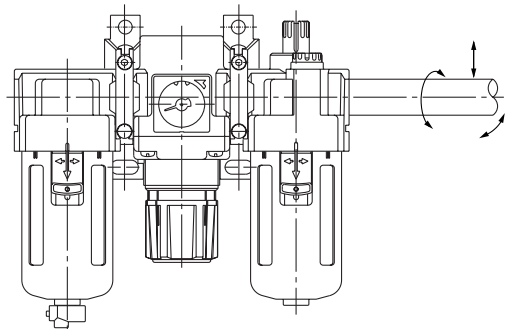

3. Piping materials without flexibility such as steel tube piping are prone to be affected by excess moment load and vibration from the piping side. Use flexible tubing in between to avoid such an effect.



F.R.L. Unit Precautions 3

Be sure to read before handling.

Piping

⚠ Caution

1. Lubricator

Try to avoid riser piping and branch lines as much as possible on the outlet side, otherwise proper lubrication will be compromised.

2. Float type auto drain

Drain piping should be performed under the following conditions to avoid malfunction.

<N.O. type>

- Use piping whose I.D. is $\phi 6.5$ or larger, and whose length is 5m or less. Avoid riser piping.

<N.C. type>

- AD17/27: Use piping whose I.D. is $\phi 2.5$ or larger
AD37/47: Use piping whose I.D. is $\phi 4$ or larger
Length is 5 m or less. Avoid riser piping.

Air supply

⚠ Caution

1. When there is excessive condensate, install a device that eliminates water such as a dryer or water separator (Drain Catch) on the inlet side of the air filter.

Maintenance

⚠ Warning

1. When disassembly or installation is required during the maintenance, repair, or replacement of a device, be sure to follow the instructions provided in the instruction manual or safety instructions in this catalog.
2. Perform periodical inspections to detect any cracks, scratches, or other deterioration of the transparent resin bowl of the air filter, filter regulator, and lubricator or the sight dome of the lubricator.
Replace with a new bowl, sight dome, or metal bowl when any kind of deterioration is found, otherwise this can cause damage.
3. Perform periodical inspections to detect dirt on the transparent resin bowl of the air filter, filter regulator, and lubricator or the sight dome of the lubricator. When you find dirt on any of the above devices, clean with a mild household cleanser. Do not use other cleaning agents, otherwise this can cause damage.
4. Air filter
 1. Replace the element every 2 years or when the pressure drop becomes 0.1MPa, whichever comes first, to prevent damage to the element.
 2. Release accumulated condensate periodically before it reaches the maximum capacity. Condensate that flows out to the outlet side can cause malfunctions.

Maintenance

⚠ Warning

5. Mist separator, micro-mist separator

1. Replace the element every 2 years or when the pressure drop becomes 0.1MPa, whichever comes first, to prevent damage to the element.
2. Release accumulated condensate periodically before it reaches the maximum capacity. Condensate that flows out to the outlet side can cause malfunctions.

6. Lubricator

1. Use class 1 turbine oil (without additives) ISO VG32. Using other lubricant can cause damage to devices and result in malfunctions.
2. For AL10 type, replenish the lubricant after releasing the inlet pressure as lubricant cannot be properly applied in a pressurized condition.

⚠ Caution

1. Perform periodical inspections of the filter element and replace it as necessary. Check the element whenever the outlet pressure drops below normal or air does not flow smoothly during operation.
2. Regulator and filter regulator
Check the sliding part or seat of the internal valve when a setting malfunction or relief leakage occur and temporary or emergency repairs need to be made.
3. Lubricator
Check the dripping amount once a day. Drip failure can cause damage to the components being lubricated.
4. Float type auto drain
 1. Turn the knob counterclockwise to release the drain manually. Avoid applying excessive torque to the knob, such as by using a tool, as this can damage an auto drain.
After releasing the condensate, turn the knob clockwise until it stops.
 2. Air leakage or other performance malfunctions can occur if premature clogging of the element or pressure drop causes the pressure inside the bowl to get outside the specified pressure range parameters. Check the pressure whenever such an irregularity occurs.



SMC'S GLOBAL MANUFACTURING, DISTRIBUTION AND SERVICE NETWORK

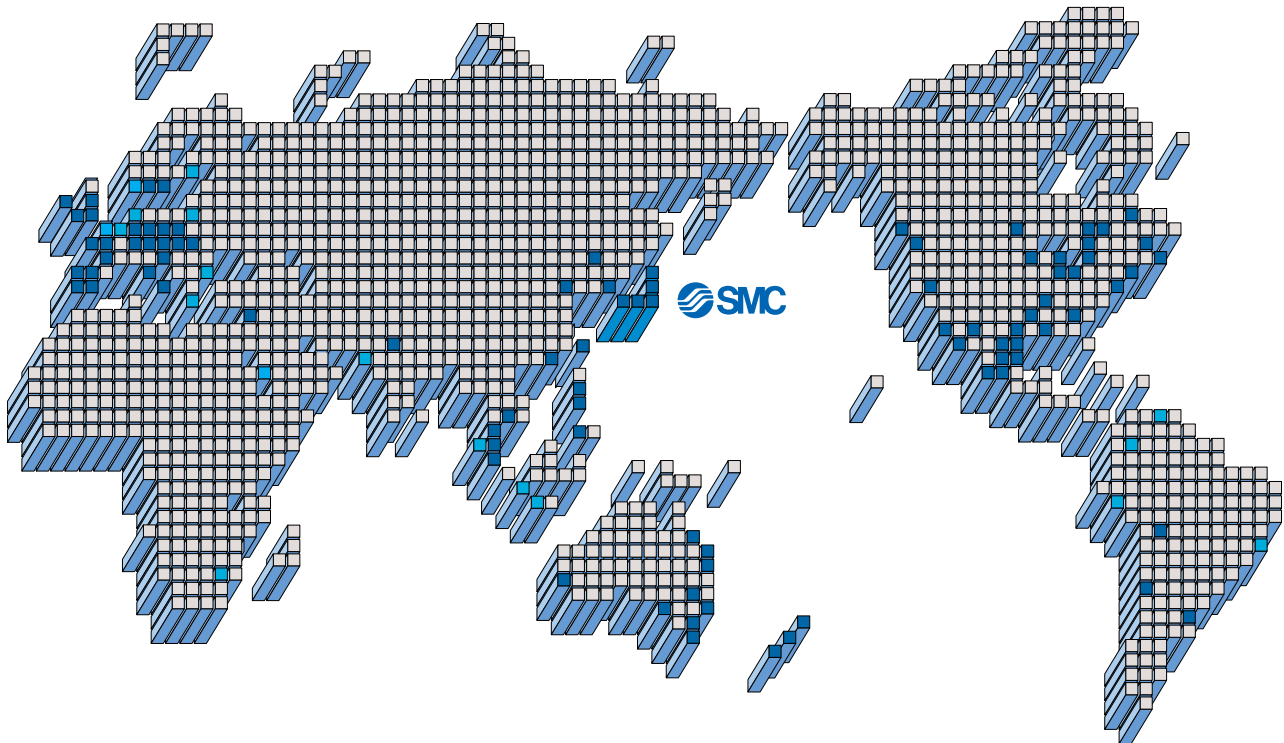

EUROPE

AUSTRIA

SMC Pneumatik GmbH

CZECH

SMC Industrial Automation CZ s.r.o.

DENMARK

SMC Pneumatik A/S

FINLAND

SMC Pneumatiikka Oy

FRANCE

SMC Pneumatique SA

GERMANY

SMC Pneumatik GmbH

HUNGARY

SMC Ipari Automatizálási Kft.

IRELAND

SMC Pneumatics (Ireland) Ltd.

ITALY

SMC Italia S.p.A.

LATVIA

SMC Pneumatics Latvia SIA

NETHERLANDS

SMC Pneumatics BV.

NORWAY

SMC Pneumatics Norway A/S

POLAND

SMC Industrial Automation Polska Sp.z.o.o.

ROMANIA

SMC Romania s.r.l.

RUSSIA

SMC Pneumatik LLC.

SLOVAKIA

SMC Priemyselná Automatizácia, s.r.o.

SLOVENIA

SMC Industrijska Avtomatika d.o.o.

SPAIN/PORTUGAL

SMC España, S.A.

SWEDEN

SMC Pneumatics Sweden AB

SWITZERLAND

SMC Pneumatik AG.

UK

SMC Pneumatics (U.K.) Ltd.

ASIA

CHINA

SMC (China) Co., Ltd.

HONG KONG

SMC Pneumatics (Hong kong) Ltd.

INDIA

SMC Pneumatics (India) Pvt. Ltd.

INDONESIA

PT. SMC Pneumatics Indonesia

MALAYSIA

SMC Pneumatics (S.E.A.) Sdn. Bhd.

PHILIPPINES

SMC Pneumatics (Philippines), Inc.

SINGAPORE

SMC Pneumatics (S.E.A.) Pte. Ltd.

SOUTH KOREA

SMC Pneumatics Korea Co., Ltd.

TAIWAN

SMC Pneumatics (Taiwan) Co., Ltd.

THAILAND

SMC Thailand Ltd.

NORTH AMERICA

CANADA

SMC Pneumatics (Canada) Ltd.

MEXICO

SMC Corporation (Mexico) S.A. de C.V.

USA

SMC Corporation of America

SOUTH AMERICA

ARGENTINA

SMC Argentina S.A.

BOLIVIA

SMC Pneumatics Bolivia S.R.L.

BRAZIL

SMC Pneumaticos Do Brazil Ltda.

CHILE

SMC Pneumatics (Chile) S.A.

VENEZUELA

SMC Neumatica Venezuela S.A.

OCEANIA

AUSTRALIA

SMC Pneumatics (Australia) Pty. Ltd.

NEW ZEALAND

SMC Pneumatics (N.Z.) Ltd.

SMC Corporation

1-16-4 Shimbashi, Minato-ku, Tokyo 105-8659 JAPAN

Tel: 03-3502-2740 Fax: 03-3508-2480

URL <http://www.smcworld.com>

© 2003 SMC CORPORATION All Rights Reserved

1st printing March, 2003 D-DN P-120 (DN)

This catalog is printed on recycled paper with concern for the global environment.

Specifications are subject to change without prior notice and any obligation on the part of the manufacturer.

Printed in Japan.