

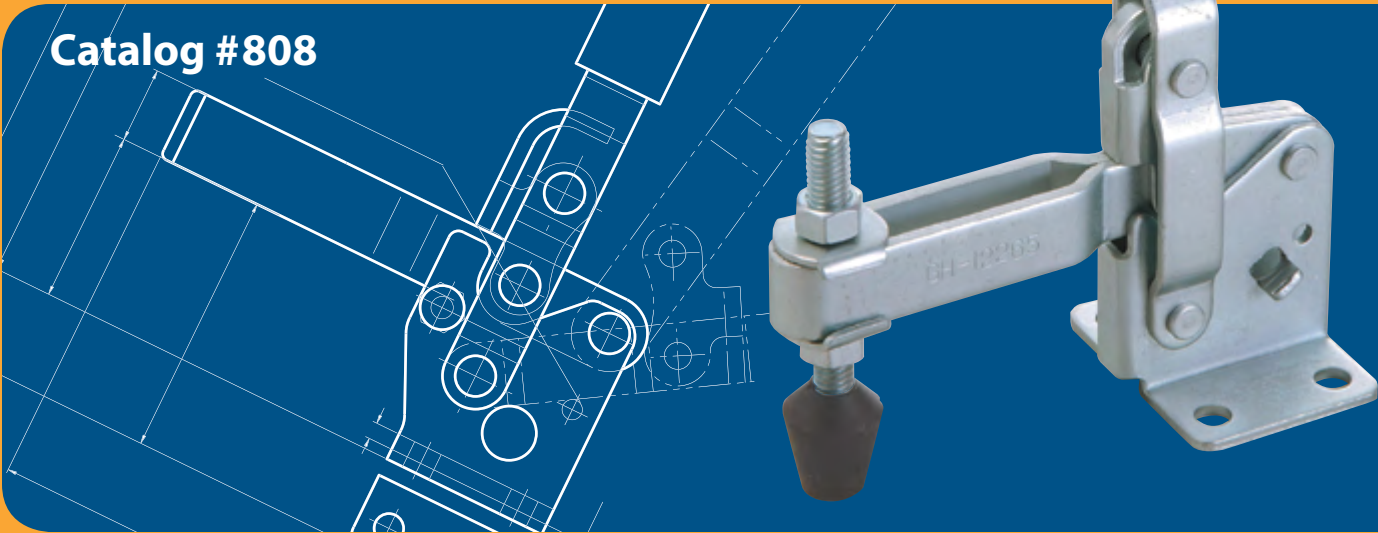

NEW
to this catalog:
STRONG HAND®
Welding Clamps
Catalog Sampler
(Pages 43-44)
Request the complete catalog
by calling Toll Free
800.989.5244



Catalog #808

***Your complete resource guide
to toggle clamps!***

www.goodhandinc.com

Distributed by:

QUALITY • DIVERSITY • ECONOMY



DRIVEN BY CUSTOMER DEMAND

For over 35 years, we've served our valued, worldwide customers by providing clamps that are built to suit a wide variety of industrial and OEM applications. Because whether you need a clamp to push, pull, hold down, lock, position, or tighten, we'll either help you find exactly what you need in our catalog, or we'll modify one of our standard clamps to your exact specifications, or we'll custom-build a clamp for you!

Our caring, highly skilled staff is devoted to helping you design a system that will solve both the *ordinary* and *repetitive*, and the *unique* and *situational* work-holding needs. With vertical, horizontal, and push/pull action, toggle clamps offer the flexibility to provide solutions in manufacturing, assembly, storage, machine building, and shop use.

We manufacture over 350 models of toggle clamps, and our new product development is ongoing and is driven by customer demand. We pride ourselves on featuring a line of clamps that offers more variety than the competition, and we are continually seeking new designs to fill a need that has not yet been met. We react to you, our valued customers, with urgency and sincere interest in meeting your requirements. We remain driven to satisfy, driven to deliver a clamping line that exceeds your expectations in quality, diversity, and economy.

Please contact us and tell us how we can best serve you...

Customer Service Hotline : 800.989.5244

Web : www.goodhandinc.com

Good Hand, Inc.
7141 Paramount Blvd.
Pico Rivera, California 90660 U.S.A.
Tel : 562.949.8625
Fax : 562.949.4875
E-Mail: sales@valtrainc.com

GOOD HAND™ QUALITY ASSURANCE

- All die-stamped steel parts are deburred, cleaned, and zinc-plated for a finish that resists corrosion and creates a smooth, easy to clean surface.
- Toggle mechanism designed to allow maximum clearance for ease of loading and unloading work-pieces.

Flanged Washers are supplied with all U- bar and open bar models. Bolt retainers are supplied with all solid bar models.

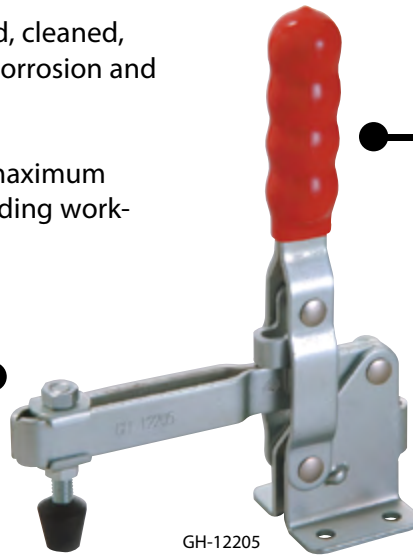

Hand grips are covered with an oil and stain resistant red vinyl or red plastic for easy identification and to assure the safety and comfort of the operator.

Toggle Action

The theoretical maximum holding of clamping force of a toggle action device is achieved when the three pivot points are in a straight line. To make allowance for external forces due to vibration and changing load conditions in industrial use, the proper amount of over travel of the center pivot point has been carefully calculated to yield maximum clamping pressure, while achieving a positive locking position.

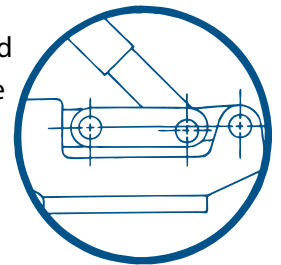

Holding Capacity and Clamping Force

All **GOOD HAND™** clamps are rated by their “holding capacity.” This rating is the maximum force the clamp will support when locked in the closed position without creating permanent deformation. This force is measured at a point closest to the base and diminishes as the end of the bar is reached. The “clamping force” is defined as the actual force being applied by the clamp to the workpiece. This rating is not constant due to such variables as the location of force on the handle, the amount of force the operator applies, and the location of the spindle on the hold-down bar.

NOTE: Engineering changes, dimensions and specifications referenced in this catalog are subject to change without notice.

UNIQUE

Look for this logo throughout our catalog to see our clamps with unique features such as:

- **Higher Base** (Greater clearance)
- **Side Mounting** (Saves fixture space)
- **Yokes** (Clamp 2 parts with 1 stroke)
- **Long U-Bolts** (Extend the reach of Latch Clamps)
- **Reverse Action** (Lowers the profile of Push Pull clamps)

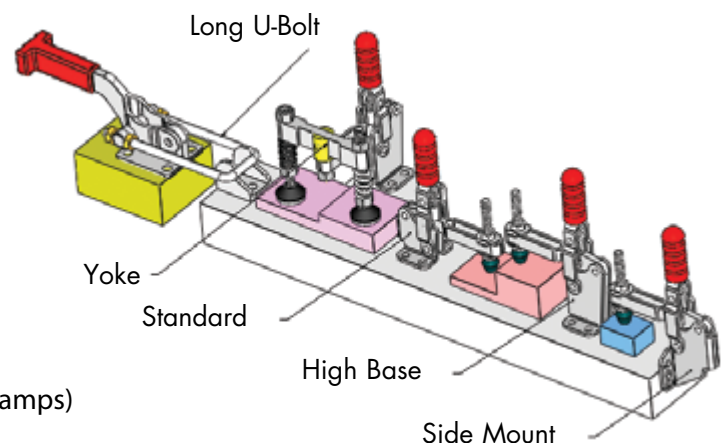



INDEX

GOOD HAND	DE-STA-CO	CARR LANE	PAGE
Vertical Handle Toggle Clamps			
101-A	201	CL-150-VTC	1
101-AI	201-B	CL-151-VTC	1
101-AIT	201-TB	-	1
101-AT	201-T	CL-152-VTC	1
101-ASS	201-SS	CL-150-VTC-S	1
11002-B	-	-	1
12002-B	-	-	1
13002-B	-	-	1
13005	305-U	CL-200-VTC	2
13005-SS	305-USS	CL-200-VTC-S	2
13005-HB	-	-	2
13005-SM	-	-	2
13007	307-U	-	2
13007-SM	-	-	2
13008	309-U	-	2
12050	202	CL-250-VTC	3
12050-U	202-U	-	3
12050-UL	202-UL	-	3
12050-SS	202-SS	CL-250-VTC-S	3
12050-HB	-	-	3
12050-SM	-	-	3
12055	202-B	CL-251-VTC	3
12060	-	-	3
12065	-	-	3
12070	202-T	CL-252-VTC	3
12075	202-TB	-	3
12080	-	-	3
12085	-	-	3
101-B	-	-	4
102-B	-	-	4
106-B	-	-	5
12205	-	-	5
12130	207-U	CL-450-VTC	6
12130-SS	207-USS	CL-450-VTC-S	6
12130-HB	-	-	6
12030-SM	-	-	6
12131	207-TU	CL-452-VTC	6
12132	207-UL	CL-453-VTC	6
12133	207-TUL	CL-452-VTC	6
12135	207-UB	CL-451-VTC	6
12136	207-TUB	-	6
12137	207-ULB	CL-451-VTC	6
12138	207-TULB	-	6
12140	207-S	CL-350-VTC	6
12141	207-TS	CL-352-VTC	6
12142	207-L	CL-353-VTC	6
12143	207-TL	CL-352-VTC	6
12145	207-SB	CL-351-VTC	6
12146	207-TSB	-	6
12147	207-LB	CL-351-VTC	6
12148	207-TLB	-	6
12265	210-U	CL-650-VTC	7
12265-SS	210-USS	CL-650-VTC-S	7
12270	204-UB	CL-651-VTC	7
12275	210-S	CL-550-VTC	7
12280	204-SB	CL-551-VTC	7
12285	210-TU	CL-652-VTC	7
12290	204-TUB	-	7
12295	210-TS	CL-552-VTC	7
12300	201-TSB	-	7
12305	-	-	7
12310	-	-	7
12315	-	CL-600-VTC	7
12320	-	CL-610-VTC	7
10444	-	-	8
10448	-	-	8
10247	247-U	CL-850-VTC	8
10248	247-UB	CL-851-VTC	8
10249	247-S	CL-750-VTC	8
12050	247-SB	CL-751-VTC	8
101-H	-	-	9
101-J	267-U	CL-1050-VTC	9
101-JS	267	CL-950-VTC	9
Horizontal Handle Toggle Clamps			
22005	-	-	10
22010	-	-	10
22025	-	-	10
22030	-	-	10
201	205-U	CL-250-HTC	10

GOOD HAND	DE-STA-CO	CARR LANE	PAGE
Horizontal Handle Toggle Clamps (cont.)			
201-SS	205-USS	CL-250-HTC-S	10
201-I	205-UB	CL-251-HTC	10
201-L	205-UL	CL-253-HTC	10
201-R	205-UR	CL-252-HTC	10
201-A	205-S	CL-150-HTC	10
201-ASS	205-SSS	CL-150-HTC-S	10
201-AI	205-SB	CL-151-HTC	10
201-AL	205-SL	CL-153-HTC	10
201-AR	205-SR	CL-152-HTC	10
20800	-	-	11
20800-SS	-	-	11
20300	-	-	11
22100	-	-	12
22105	-	-	12
20752-B	-	CL-260-HTC	12
21502-B	-	-	12
22502-B	-	-	12
201-B	215-U	CL-350-HTC	13
201-BSS	215-USS	CL-350-HTC-S	13
201-BI	215-UB	CL-351-HTC	13
201-BS	215-S	CL-300-HTC	13
201-BSI	215-SB	-	13
201-BHB	-	-	13
201-BSM	-	-	13
20820	317-U	CL-475-HTC	14
203-F	-	-	14
203-FL	-	-	14
202-F	-	-	14
202-FL	-	-	14
225-D	225-U	CL-450-HTC	15
225-DSS	225-USS	CL-450-HTC-S	15
225-DI	225-UB	CL-451-HTC	15
225-DHB	-	-	15
225-DSM	-	-	15
22165	-	-	16
22170	-	-	16
22175	-	-	16
22180	-	-	16
22185	-	-	16
22190	-	-	16
22195	-	-	16
22200	-	-	16
21383	-	-	16
25383	-	-	17
22235	-	-	17
25382	-	-	18
21385	-	-	18
20235	235-U	CL-550-HTC	19
20235-SS	235-USS	CL-550-HTC-S	19
20236	235-UB	CL-551	19
200-W	-	-	19
200-WL	-	-	19
200-WH	-	-	19
200-WLH	-	-	19
220-WH	-	-	19
220-WLH	-	-	19
204-GB	-	-	20
204-GBL	-	-	20
204-GBLH	-	-	20
204-G	-	-	20
204-GL	-	-	20
Push/Pull Toggle Clamps			
301-A	601	CL-50-SPC	21
301-B	-	-	21
36006	-	-	21
36070	-	-	21
302-F	605	CL-150-SPC	22
302-FSS	-	-	22
302-D	-	-	22
30282	-	-	22
36092	609	-	22
36020	-	-	23
36003	603	CL-100-PC	23
30290	-	-	23
30292	-	-	23
36060	620	CL-275-SPC	24
30607	607	-	24
36010	610	CL-250-SPC	24
36012	618	-	24

GOOD HAND	DE-STA-CO	CARR LANE	PAGE
Push/Pull Toggle Clamps (cont.)			
303-EK	-	-	25
36330	630	CL-350-TPC	25
30250	-	-	25
30450	-	-	25
36202	602	CL-150-TPC	26
36204	604	CL-250-TPC	26
36204-SS	604-SS	-	26
36205	-	-	26
36224	624	CL-350-TPC	26
36225	-	-	26
304-C	-	-	26
304-E	608	CL-200-PC	26
304-H	-	-	26
305-C	-	-	26
305-E	-	-	26
305-H	-	-	26
30509	-	-	27
30609	-	-	27
30519	-	-	27
30619	-	-	27
Latch Type Toggle Clamps			
40323	323	CL-100-PA	28
40323-SS	323-MSS	CL-100-PA-S	28
40323-LUB	-	-	28
40323-LUBSS	-	-	28
431	331	CL-200-PA	28
431-SS	331-SS	CL-200-PA-S	28
431-LUB	-	-	28
431-LUBSS	-	-	28
40341	341	CL-300-PA	28
40341-SS	341-SS	CL-300-PA-S	28
40341-LUB	-	-	28
40341-LUBSS	-	-	28
40820	-	-	28
40840	-	-	28
40870	-	-	28
40324	324	CL-110-PA	29
40334	334	CL-210-PA	29
40344	344	CL-310-PA	29
451	351	CL-250-PA	29
451-LP	351000	CL-250-PA-L	29
451-LPSS	351900	CL-250-PA-S-L	29
451-SS	351-SS	CL-250-PA-S	29
452	351-B	CL-251-PA	29
452-LP	-	CL-251-PA-L	29
452-LPSS	-	CL-250-PA-S-L	29
452-SS	351-BSS	-	29
40371	371	-	29
40371-LP	371000	-	29
43810	381	CL-350-PA	29
43810-LP	381000	CL-350-PA-L	29
43101	301	CL-150-PA	30
43101-LP	-	-	30
43110	-	-	30
43110-LP	-	-	30
43120	-	-	30
43120-LP	-	-	30
43150	-	-	30
43150-LP	-	-	30
43160	-	-	30
43160-LP	-	-	30
40370	378	CL-400-PA	31
40370-LP	385105	CL-500-PAA	31
40380	385	CL-500-PA	31
Toggle Pliers			
50350	424	CL-50-PL	32
50360	441	CL-150-PL	32
50380	462	CL-254-PL	32
50385	-	-	32
61352	-	-	33
50450	463	CL-454-PL	33
50480	480	-	33
Cam Type Toggle Clamps			
60130	-	-	34
60131	-	-	34

GOOD HAND	DE-STA-CO	CARR LANE	PAGE
Heavy Duty Weldable Toggle Clamps			
701-C	-	-	35
701-D	-	-	35
701-K	-	-	35
702-C	-	-	35
702-D	-	-	35
702-K	-	-	35
70305	503-M	-	35
70310	503-MB	-	35
70315	503-MLB	-	35
70505	505-M	-	35
70510	505-MB	-	35
70515	505-MLB	-	35
70605	506-M	-	35
70610	506-MB	-	35
70615	506-MLB	-	35
75027	527	-	36
75027-SM	527-F	-	36
75048	548	-	36
75078	578	-	36
F-Type Clamps			
80070	-	-	37
80325	325	CL-325-PL-S	37
80325-SS	325-SS	-	37
Pneumatic Power Clamps			
10101-A	812	CL-400-PTC	38
12050-A	802	CL-500-PTC	38
12130-A	807-UL	CL-1001-PTC	38
12132-A	-	CL-1000-PTC	38
12265-A	810-U	-	38
12275-A	810-S	-	38
10247-A	847-U	CL-2000-PTC	38
10249-A	847-S	CL-2001-PTC	38
20820-A	-	-	38
36301-A	816	CL-600-PPC	39
36003-A	803	CL-1500-PPC	39
36330-A	830	-	39
Yoke Assemblies			
YB-3130	-	-	39
YB-3145	-	-	39
YB-3160	-	-	39
YB-3730	-	-	39
YB-3745	-	-	39
YB-3760	-	-	39
YN-3130	-	-	39
YN-3145	-	-	39
YN-3160	-	-	39
YN-3730	-	-	39
YN-3745	-	-	39
YN-3760	-	-	39
YP-3130	-	-	39
YP-3145	-	-	39
YP-3160	-	-	39
YP-3730	-	-	39
YP-3745	-	-	39
YP-3760	-	-	39
Accessories			40
Appendix			41
Valtra™ Products Sampler			42
Strong Hand® Products Sampler			43-44

PICTORIAL INDEX

Vertical Handle
Hold Down Action

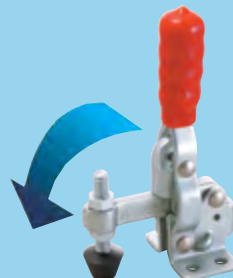

PAGES 1-9

Horizontal Handle
Hold Down Action



PAGES 10-20

Push/Pull
Straight Line Action

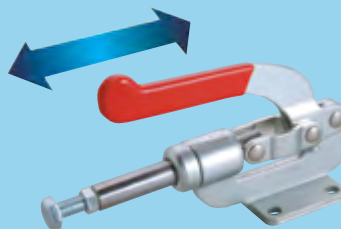

PAGES 21-27

Latch Type
Pull Action

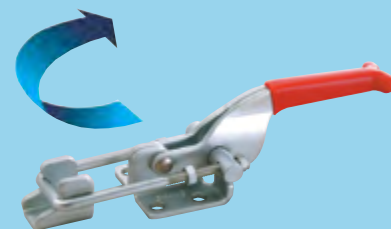

PAGES 28-31

Toggle Pliers
Squeeze Action



PAGES 32-33

Cam Type
Hold Down Action



PAGES 34

Heavy Duty Weldable
Hold Down Action



PAGES 35-36

F-Type
Pull Down Action



PAGE 37

Pneumatic Power



PAGES 38-39

Yoke Assemblies

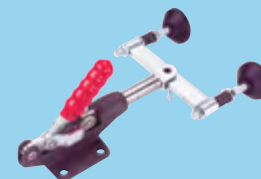

PAGE 39

Accessories	40
Appendix	41
Valtra™ Products Sampler	42
Strong Hand® Products Sampler	43-44

Series 101-A

- Cross Ref. : DE-STA-CO Series 201
- Holding Capacity: 110 lbs. (50 kg)
- Weight: 0.13 lb. (60 g)
- Bar opens 100°, Handle 56°
- Spindle Supplied: GH-FC-10138

One of the most affordable clamps. T-handle and straight base options available.

Model	Description
GH-101-A	U-Bar, Flanged Base, Straight Handle
GH-101-ASS	Stainless Steel Model of GH-101-A
GH-101-AI	U-Bar, Straight Base, Straight Handle
GH-101-AIT	U-Bar, Straight Base, T-Handle
GH-101-AT	U-Bar, Flanged Base, T-Handle

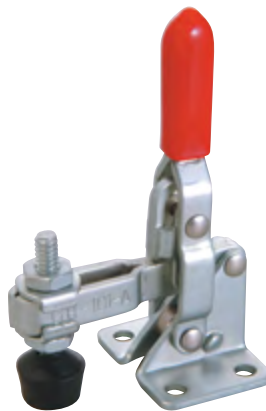

GH-101-A

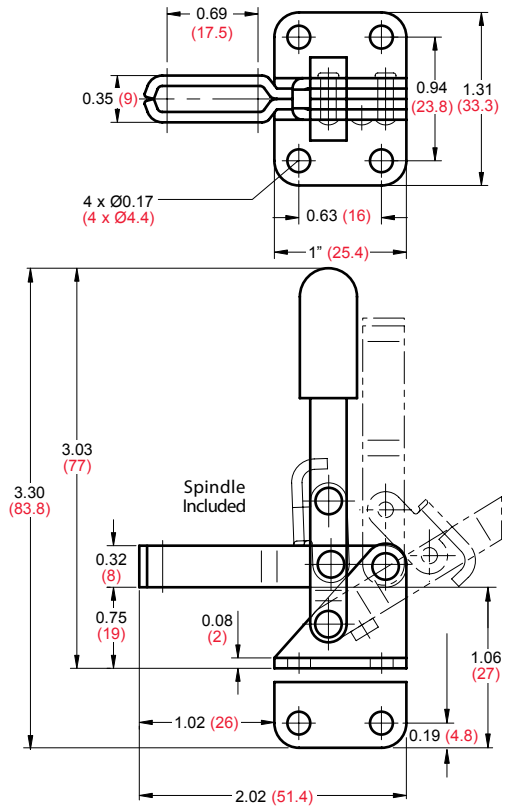

UNIT: inch (metric mm)

Series 11002-B

- GH-13002-B has **hardened bushings** and **removable ground pins**.

Unique hole pattern for flexibility in a wide range of mounting options.



GH-13002-B

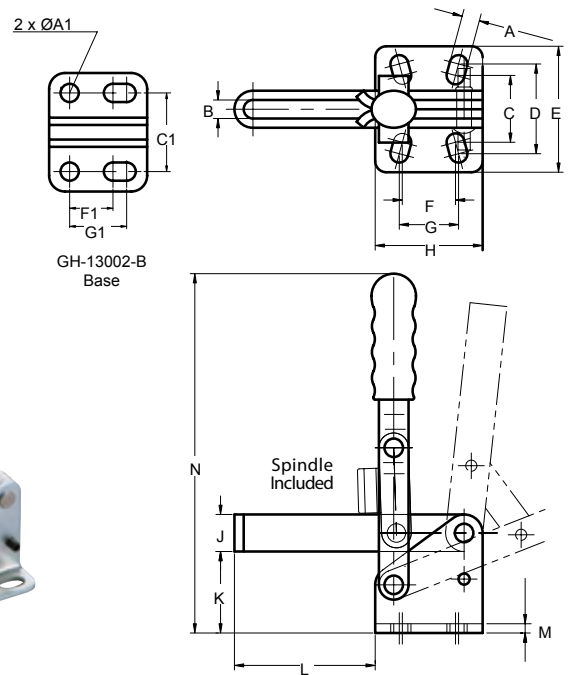

Model	Holding Capacity	Spindle Supplied	Bar Opens	Handle Opens	A	A1	B	C	C1	D	E	F	F1	G	H	J	K	L	M	N	Weight
GH-11002-B	165 lbs. (75 kg)	GH-SA-10118	96°	66°	0.32 (8)	-	0.20 (5)	0.70 (18)	-	0.95 (24.2)	1.34 (34)	0.56 (14.3)	-	0.63 (16)	1.14 (29)	0.39 (10)	0.87 (22)	1.50 (38)	0.10 (2.5)	3.82 (97)	0.28 lb. (128 g)
GH-12002-B	330 lbs. (150 kg)	GH-SA-14134	108°	70°	0.32 (8)	-	0.25 (6.4)	1" (25.4)	-	1.06 (27)	1.65 (42)	0.50 (12.7)	-	0.75 (19)	1.38 (35)	0.51 (13)	1.22 (31)	1.73 (44)	0.13 (3.2)	5.63 (143)	0.37 lb. (170 g)
GH-13002-B	550 lbs. (250 kg)	GH-SA-56212	106°	67°	-	0.32 (8)	0.35 (8.8)	-	1.32 (33.5)	-	2.01 (51.1)	-	0.75 (19)	1" (25.4)	1.69 (43)	0.75 (19)	1.38 (35)	3.94 (100)	0.13 (3.2)	7.72 (196)	0.84 lb. (380 g)

UNIT: inch (metric mm)

Series 13005

- Cross Ref. : DE-STA-CO Series 305
- Bar opens 90°, Handle 175°
- GH-13008 has **hardened bushings** and **removable ground pins**.

This unique space-saving clamp is very affordable.



GH-13005

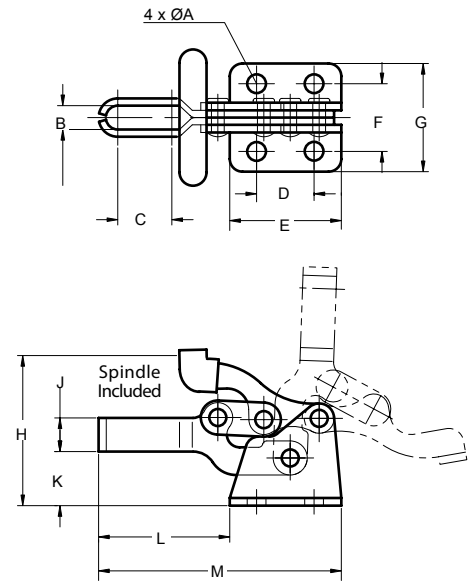

Model	Holding Capcty	Spindle Supplied	ØA	B	C	D	E	F	G	H	J	K	L	M	Weight
GH-13005	150 lbs. (68 kg)	GH-FC-10138	0.17 (4.4)	0.35 (9)	0.50 (12.7)	0.53 (13.5)	1.03 (26.2)	0.63 (15.9)	1" (25.4)	1.40 (35.2)	0.31 (7.9)	0.50 (12.7)	1.21 (30.8)	2.24 (57)	0.13 lb. (60 g)
GH-13005-SS Stainless Steel Model of GH-13005															
GH-13007	330 lbs. (150 kg)	GH-FC-56212	0.28 (7)	0.60 (15.2)	0.77 (19.5)	1.06 (27)	1.73 (44)	1.16 (29.4)	1.81 (46)	2.31 (58.7)	0.50 (12.7)	0.87 (22.2)	1.97 (50.1)	3.69 (93.7)	0.50 lb. (230 g)
GH-13008	705 lbs. (320 kg)	GH-FC-38312	0.31 (7.9)	0.75 (19)	1.14 (28.9)	1.54 (39)	2.53 (64.3)	1.50 (38.1)	2.46 (62.7)	3.46 (88.1)	0.75 (19)	1.31 (33.3)	2.66 (67.5)	5.32 (135)	1.38 lbs. (630 g)

UNIT: inch (metric mm)

UNIQUE

13005-HB

- **High Base** Model of GH-13005



GH-13005-HB

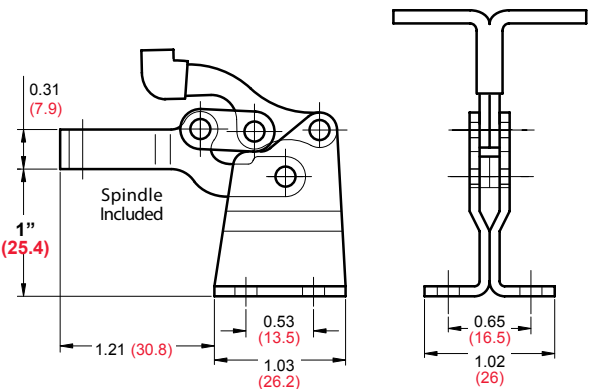

UNIT: inch (metric mm)

UNIQUE

13005-SM & 13007-SM

- **Side Mount** Model of GH-13005 and GH-13007

Unique hole pattern for flexibility in a wide range of mounting options.



GH-13005-SM

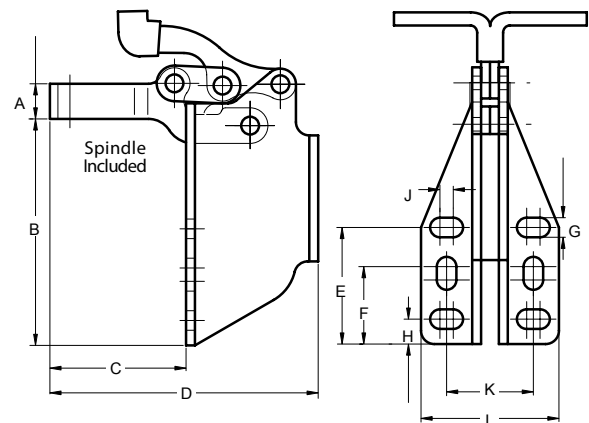

Model	A	B	C	D	E	F	G	H	J	K	L
GH-13005-SM	0.31 (7.9)	2" (50.8)	1.20 (30.6)	2.37 (60.3)	1.03 (26.2)	0.68 (17.4)	0.17 (4.4)	0.22 (5.6)	0.12 (3)	0.76 (19.5)	1.22 (31)
GH-13007-SM	0.50 (12.7)	3.06 (77.8)	1.97 (50.1)	3.80 (96.7)	1.54 (39.2)	1.04 (26.3)	0.28 (7)	0.37 (9.4)	0.16 (4)	1" (25.4)	1.81 (46)

UNIT: inch (metric mm)

Series 12050 Popular!

- Cross Ref. : DE-STA-CO Series 202
- Holding Capacity: 200 lbs. (91 kg)
- Weight: 0.38 lbs (170 g)
- Bar opens 100°, Handle 60°
- Spindle Supplied: GH-FC-14134



GH-12050

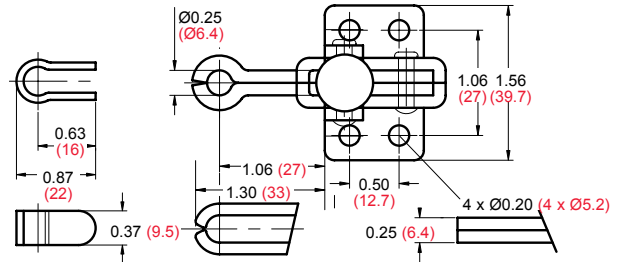

Model	Description
GH-12050	Fixed Spindle, Flanged Base, Straight Handle
GH-12050-SS	Stainless Steel Model of GH-12050
GH-12050-U	U-Bar, Flanged Base, Straight Handle
GH-12050-UL	Extra Long U-Bar 2.27" (58mm) Flanged Base, Straight Handle
GH-12055	Fixed Spindle, Straight Base, Straight Handle
GH-12060	Solid Bar, Flanged Base, Straight Handle
GH-12065	Solid Bar, Straight Base, Straight Handle
GH-12070	Fixed Spindle, Flanged Base, T-Handle
GH-12075	Fixed Spindle, Straight Base, T-Handle
GH-12080	Solid Bar, Flanged Base, T-Handle
GH-12085	Solid Bar, Straight Base, T-Handle



GH-12050-U

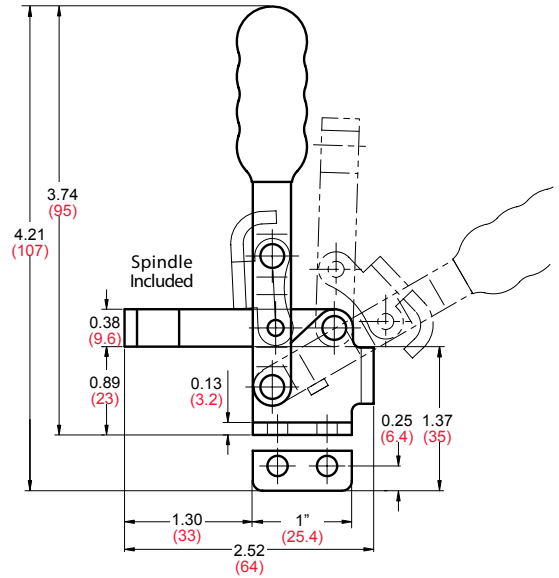

UNIQUE

12050-HB

- High Base Model of GH-12050



GH-12050-HB

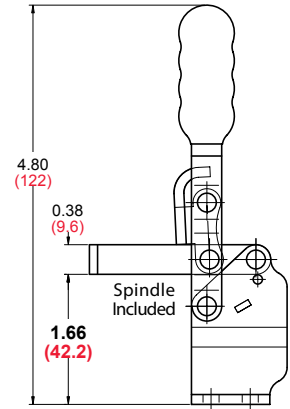

UNIQUE

12050-SM

- Side Mount Model of GH-12050



GH-12050-SM

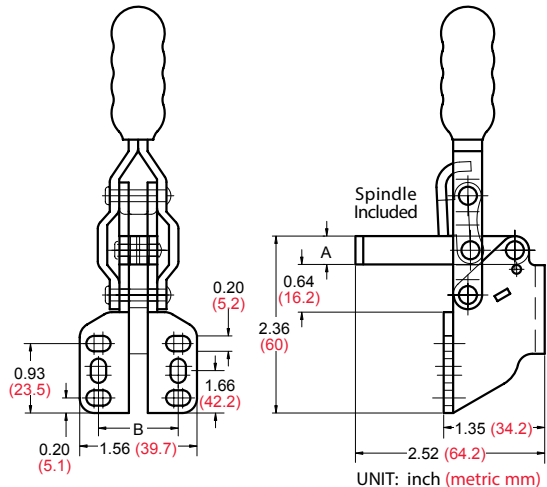

Model	A	B
GH-12050-SM	0.38 (9.6)	1.06 (27)

UNIT: inch (metric mm)

UNIT: inch (metric mm)

102-B

- Holding Capacity: 220 lbs. (100 kg)
- Weight: 0.25 lb. (115 g)
- Bar opens 90°, Handle 65°
- Spindle Supplied: GH-FC-14134

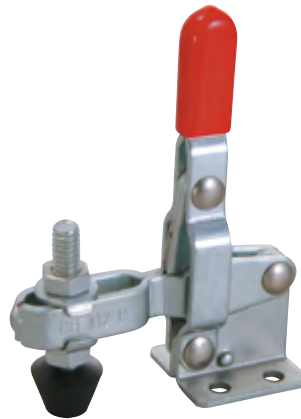

GH-102-B

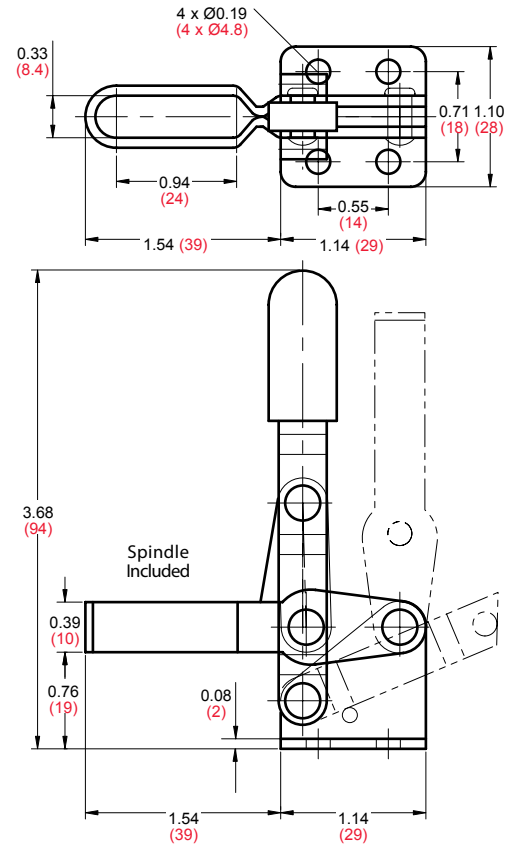

UNIT: inch (metric mm)

101-B

- Holding Capacity: 220 lbs. (100 kg)
- Weight: 0.3 lb. (135 g)
- Bar opens 90°, Handle 65°
- Spindle Supplied: GH-FC-14134



GH-101-B

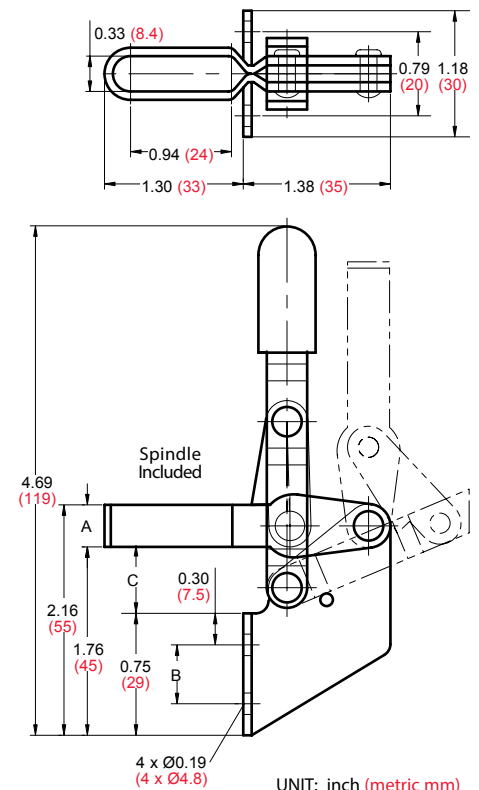

UNIT: inch (metric mm)

Model	A	B	C
GH-101-B	0.39 (10)	0.55 (14)	1 (25.4)

UNIT: inch (metric mm)

106-B

- Holding Capacity: 220 lbs. (100 kg)
- Weight: 0.4 lb. (184 g)
- Bar opens 82°, Handle 55°
- Spindle Supplied: GH-FC-14134



GH-106-B

Model	A	B	C
GH-106-B	0.30 (7.6)	0.75 (19.1)	0.25 (6.5)

UNIT: inch (metric mm)

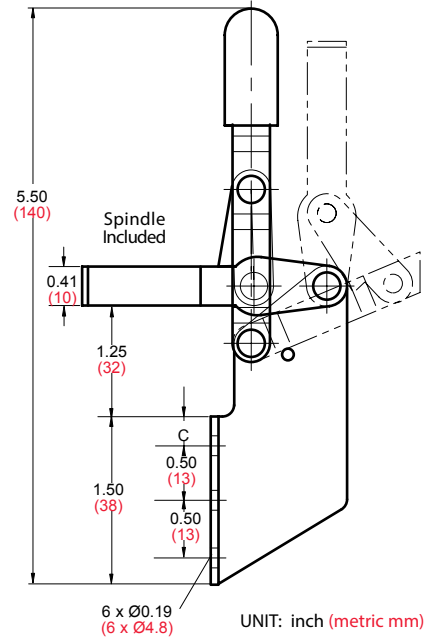
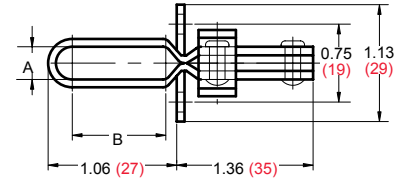

UNIT: inch (metric mm)

12205

- Holding Capacity: 400 lbs. (182 kg)
- Weight: 1.36 lbs. (620 g)
- Bar opens 100°, Handle 57°
- Spindle Supplied: GH-FC-56212



GH-12205

Model	A	B	C	D	E	F
GH-12205	1.37 (35)	2.12 (54)	1.13 (28.6)	1.94 (49.2)	0.75 (19)	0.13 (3.2)

UNIT: inch (metric mm)

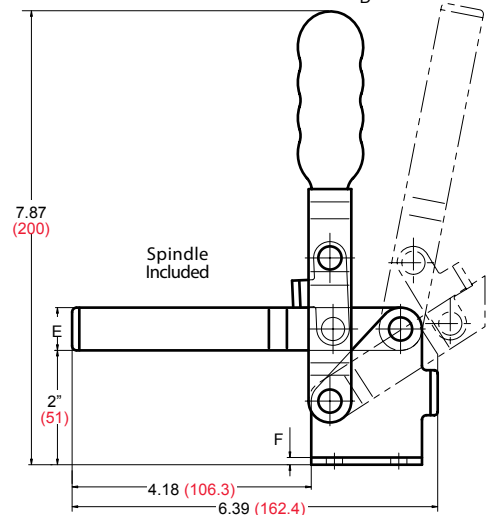
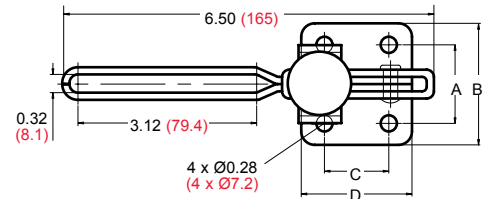

UNIT: inch (metric mm)

Series 12130 Popular!

- Cross Ref. : DE-STA-CO Series 207
- Holding Capacity: 500 lbs. (227 kg)
- Bar opens 100°, Handle 60°
- Spindle Supplied: GH-FC-56212

Expanded Selection. This is the most popular vertical handle toggle clamps. Many options are available.

Model	Description	Weight
GH-12130	Short U-Bar, Flanged Base, Straight Handle	0.78 lb. (355 g)
GH-12130-SS	Stainless Steel Model of GH-12130	
GH-12131	Short U-Bar, Flanged Base, T-Handle	0.81 lb. (370 g)
GH-12132	Long U-Bar, Flanged Base, Straight Handle	0.81 lb. (370 g)
GH-12133	Long U-Bar, Flanged Base, T-Handle	0.88 lb. (400 g)
GH-12135	Short U-Bar, Straight Base, Straight Handle	0.78 lb. (355 g)
GH-12136	Short U-Bar, Straight Base, T-Handle	0.81 lb. (370 g)
GH-12137	Long U-Bar, Straight Base, Straight Handle	0.81 lb. (370 g)
GH-12138	Long U-Bar, Straight Base, T-Handle	0.88 lb. (400 g)
GH-12140	Short Solid Bar, Flanged Base, Straight Handle	0.75 lb. (340 g)
GH-12141	Short Solid Bar, Flanged Base, T-Handle	0.78 lb. (355 g)
GH-12142	Long Solid Bar, Flanged Base, Straight Handle	0.78 lb. (355 g)
GH-12143	Long Solid Bar, Flanged Base, T-Handle	0.81 lb. (375 g)
GH-12145	Short Solid Bar, Straight Base, Straight Handle	0.75 lb. (340 g)
GH-12146	Short Solid Bar, Straight Base, T-Handle	0.78 lb. (355 g)
GH-12147	Long Solid Bar, Straight Base, Straight Handle	0.78 lb. (355 g)
GH-12148	Long Solid Bar, Straight Base, T-Handle	0.81 lb. (375 g)

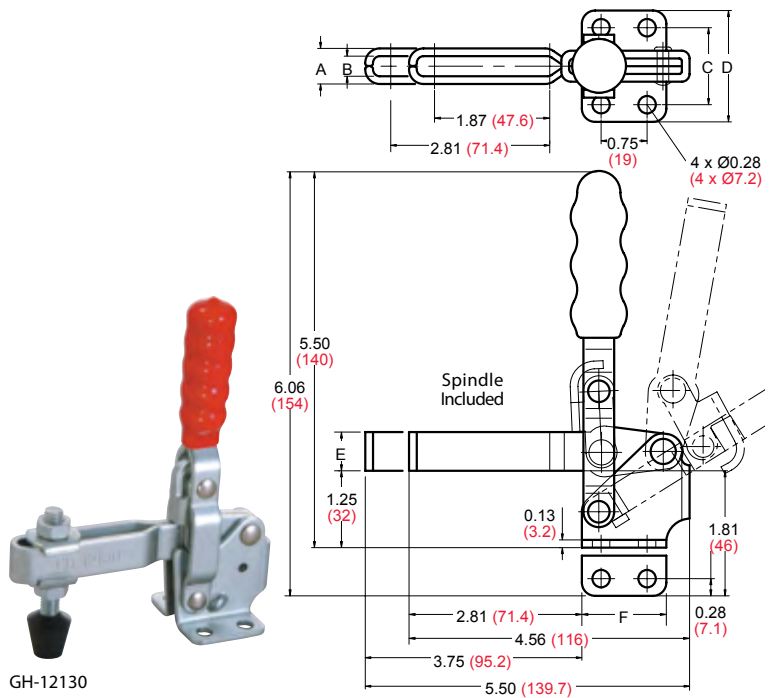

GH-12130

Model	A	B	C	D	E	F
All	0.58 (14.7)	0.33 (8.3)	1.25 (31.8)	1.81 (46)	0.63 (16)	1.37 (35)

UNIT: inch (metric mm)

UNIQUE 12130-HB

- High Base Model of GH-12130



GH-12130-HB

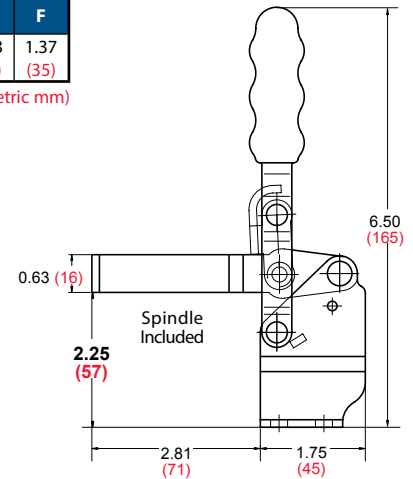

UNIQUE 12130-SM

- Side Mount Model of GH-12130



GH-12130-SM

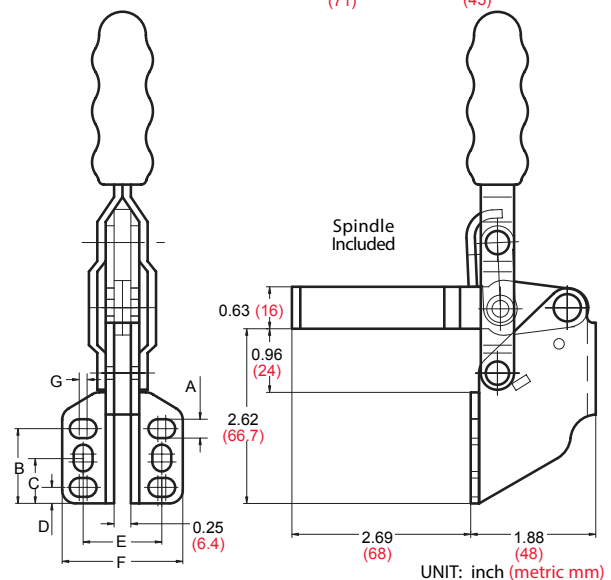

Model	A	B	C	D	E	F	G
All	0.28 (7.2)	1.12 (28.5)	0.69 (17.5)	0.24 (6.1)	1.18 (30)	1.81 (46)	0.12 (3)

UNIT: inch (metric mm)

Series 12265 Popular!

- Cross Ref. : DE-STA-CO Series 210
- Holding Capacity: 750 lbs. (340 kg)
- Bar opens 105°, Handle 58°
- Spindle Supplied: GH-FC-38312
- **Hardened bushings and removable ground pins**

Model	A	B	C	D	E	F
All	1.78 (45.3)	2.53 (64.3)	1.25 (31.8)	1.94 (49.2)	0.75 (19)	0.13 (3.2)

UNIT: inch (metric mm)

Model	Description	Weight
GH-12265	U-Bar, Flanged Base, Straight Handle	1.40 lbs. (635 g)
GH-12265-SS	Stainless Steel Model of GH-12265	
GH-12270	U-Bar, Straight Base, Straight Handle	1.40 lbs. (635 g)
GH-12275	Solid Bar, Flanged Base, Straight Handle	1.50 lbs. (680 g)
GH-12280	Solid Bar, Straight Base, Straight Handle	1.50 lbs. (680 g)
GH-12285	U-Bar, Flanged Base, T-Handle	1.57 lbs. (710 g)
GH-12290	U-Bar, Straight Base, T-Handle	1.57 lbs. (710 g)
GH-12295	Solid Bar, Flanged Base, T-Handle	1.62 lbs. (735 g)
GH-12300	Solid Bar, Straight Base, T-Handle	1.62 lbs. (735 g)



GH-12265

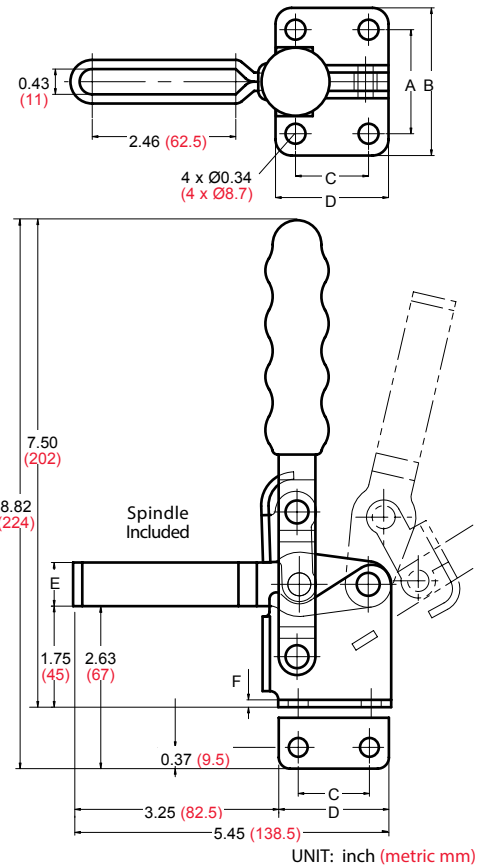

UNIT: inch (metric mm)

Series 12305

- Holding Capacity: 750 lbs. (364 kg)
- Weight: 2.18 lbs. (990 g)
- Bar opens 100°, Handle 65°
- Spindle Supplied: GH-FC-38312

Note the angular spindle bar. Available with open or solid spindle bars. Solid bar can be shortened, and the supplied bolt retainer welded on. Angular bar keeps the overall height low, yet bar clearance high.

Model	A	B	C	D	E	F
All	1.25 (31.8)	2.13 (54)	1.13 (28.6)	2.06 (52.4)	0.56 (14.3)	1.63 (41.3)

UNIT: inch (metric mm)

Model	Description
GH-12305	Open bar, Flanged Base
GH-12310	Open Bar, Straight Base
GH-12315	Solid Bar, Flanged Base
GH-12320	Solid Bar, Straight Base



GH-12305

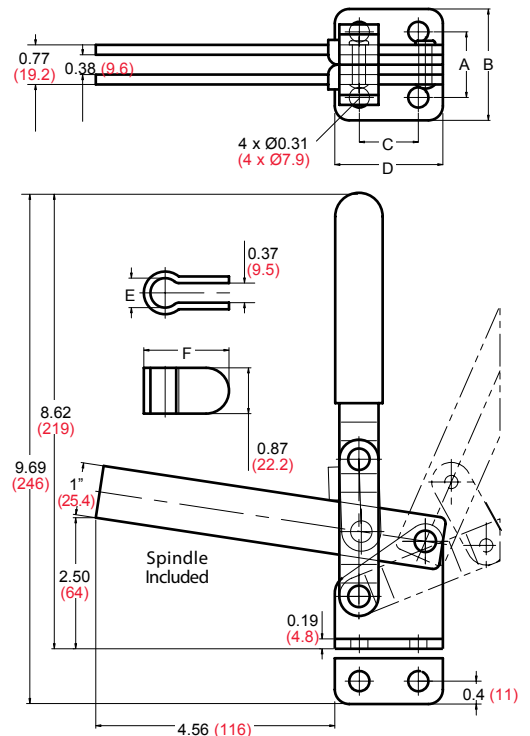

Series 10444 Welder's Choice!

- Holding Capacity: 880 lbs. (400 kg)
- Bar opens: 85°, Handle 58°
- Spindle Supplied: GH-SA-38300
- **Hardened bushings** and **removable ground pins**

This rugged yet smooth functioning clamp is designed for use in ovens. It has a rounded handle with no plastic cover.



GH-10448

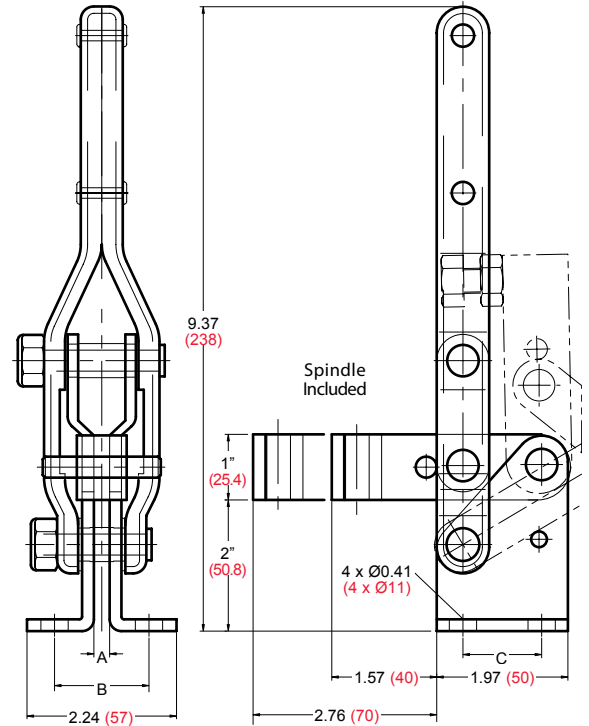

UNIT: inch (metric mm)

Model	Description	A	B	C	Weight
GH-10444	Long Bar	0.24	1.42	1.18	1.92 lbs. (870 g)
GH-10448	Short Bar	(6)	(36)	(30)	1.85 lbs. (840 g)

UNIT: inch (metric mm)

Series 10247

- Cross Ref. : DE-STA-CO Series 247
- Holding Capacity: 1,000 lbs. (450 kg)
- Weight: 2.76 lb. (1250 g)
- Bar opens 100°, Handle 58° (with roll pin)
- Bar opens 135°, Handle 70° (without roll pin)
- Spindle Supplied: GH-SA-12300
- **Hardened bushings** and **removable ground pins**

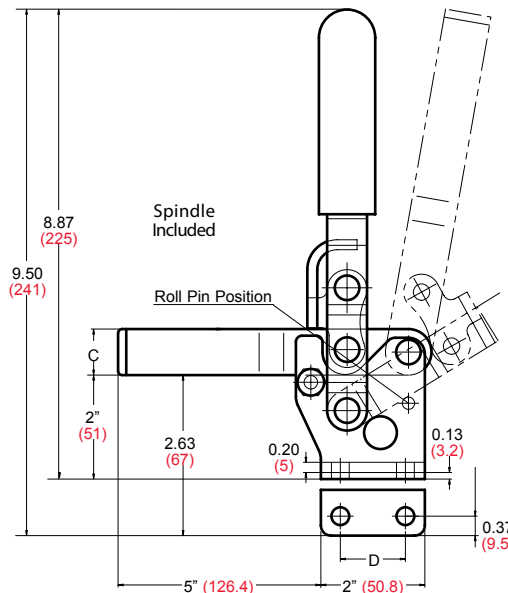
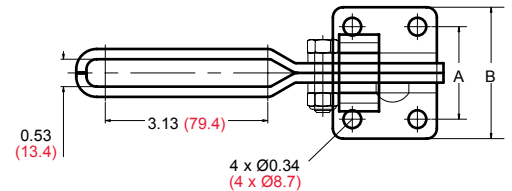

UNIT: inch (metric mm)

Model	A	B	C	D
All	1.78 (45.2)	2.53 (64.3)	0.89 (22.6)	1.25 (31.8)

UNIT: inch (metric mm)

Model	Description
GH-10247	U-Bar, Flanged Base
GH-10248	U-Bar, Straight Base
GH-10249	Solid Bar, Flanged Base
GH-10250	Solid Bar, Straight Base

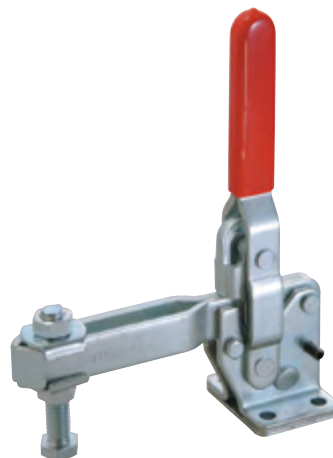

GH-10247

101-H

- Holding Capacity: 1,000 lbs. (450 kg)
- Weight: 2.69 lb. (1220 g)
- Bar opens 101°, Handle 63°
- Spindle Supplied: GH-SA-12300



GH-101-H

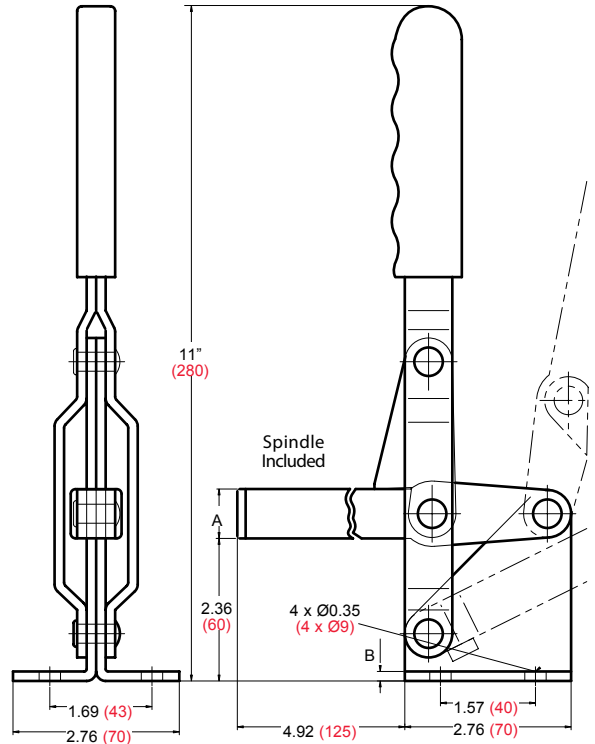

UNIT: inch (metric mm)

Model	A	B
GH-101-H	0.82 (20.8)	0.16 (4)

UNIT: inch (metric mm)

Series 101-J

- Cross Ref. : DE-STA-CO Series 267
- Holding Capacity: 1,200 lbs. (550 kg)
- Weight: 5.6 lb. (2,540 g)
- Bar opens 100°, Handle 48° (with roll pin on top)
- Bar opens 140°, Handle 60° (with roll pin on bottom)
- Spindle Supplied: GH-SA-58500
- **Hardened bushings** and **removable ground pins**



GH-101-J

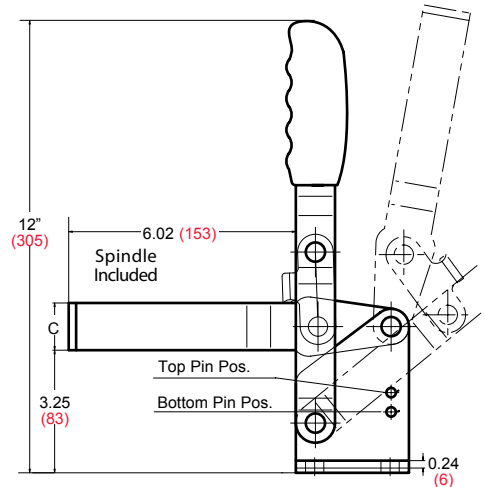
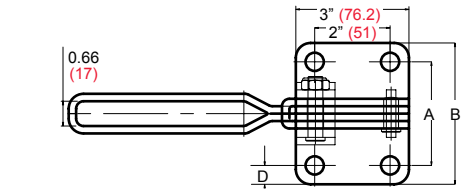

UNIT: inch (metric mm)

Model	A	B	C	D
All	2.75 (70)	3.75 (95.2)	1.25 (31.8)	0.50 (13)

UNIT: inch (metric mm)

Model	Description
GH-101-J	U-Bar, Flanged Base
GH-101-JS	Solid Bar, Flanged Base

Series 22005

- Holding Capacity: 50 lbs. (22.7 kg)
- Weight: 0.06 lb. (25 g)
- Bar opens: 90°, Handle 60°
- Spindle Supplied: GH-SA-08034 (Nylon)



GH-22025

Model	A	B	C	D
All	0.38 (9.6)	0.19 (4.76)	0.40 (10.2)	0.40 (10.2)

UNIT: inch (metric mm)

Model	Description
GH-22005	High Bar, Flanged Base
GH-22010	High Bar, Straight Base
GH-22025	Low Bar, Flanged Base
GH-22030	Low Bar, Straight Base

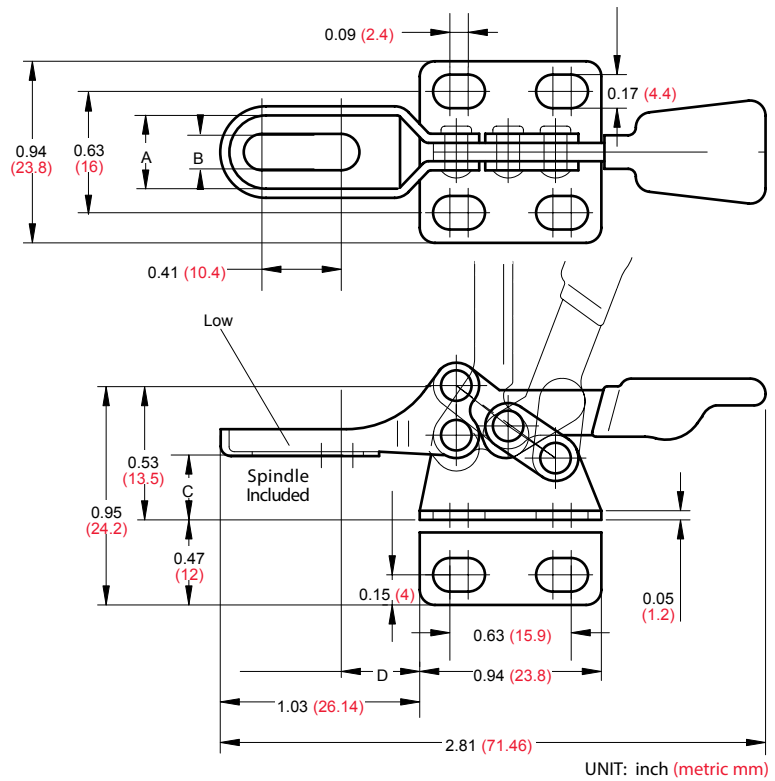

UNIT: inch (metric mm)

Series 201

- Cross Ref.: DE-STA-CO Series 205
- Holding Capacity: 60 lbs. (27 kg)
- Weight: 0.09 lb. (40 g)
- Bar opens: 90°, Handle 80°
- Spindle Supplied: GH-SA-08034 (Nylon)

This compact clamp is the most economical horizontal toggle clamp. Most suitable for holding down sheet metal or circuit boards. Many spindle bar and base combinations available.

Model	A	ØB	C	D	E
All	0.19 (4.83)	0.37 (9.4)	0.37 (9.4)	0.08 (2)	0.69 (17.5)

UNIT: inch (metric mm)

Model	Description
GH-201	U-Bar, Flanged Base
GH-201-SS	Stainless Steel Model of GH-201
GH-201-I	U-Bar, Straight Base
GH-201-L	U-Bar, Left Hand Flanged Base
GH-201-R	U-Bar, Right Hand Flanged Base
GH-201-A	Fixed Bar, Flanged Base
GH-201-ASS	Stainless Steel Model of GH-201-A
GH-201-AI	Fixed Bar, Straight Base
GH-201-AL	Fixed Bar, Left Hand Flanged Base
GH-201-AR	Fixed Bar, Right Hand Flanged Base



GH-201



GH-201-A

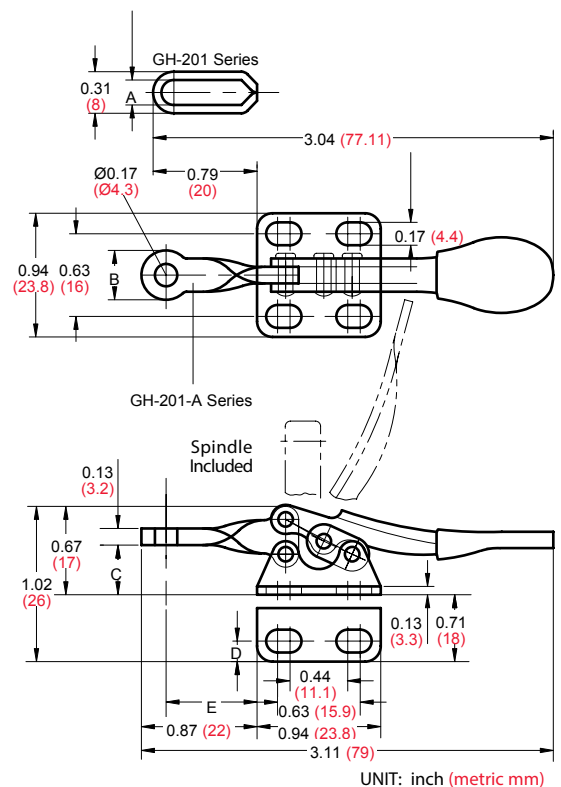

UNIT: inch (metric mm)

20800 & 20800-SS

- Holding Capacity: 66 lbs. (30 kg)
- Weight: 0.09 lbs. (40 g)
- Bar opens: 80°, Handle 88°
- Spindle Supplied

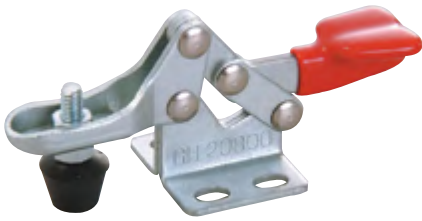

GH-20800

Model	A	B	C	D	E
All	0.16 (4)	0.22 (5.5)	0.35 (9)	0.55 (14)	0.95 (24)

UNIT: inch (metric mm)

Model	Description
GH-20800	Flanged Base
GH-20800-SS	Stainless Steel Model of GH-20800

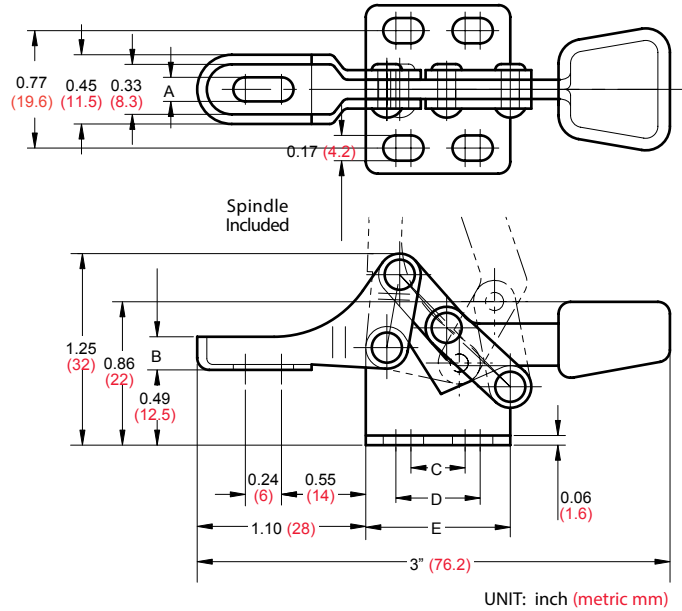

20300

- Holding Capacity: 66 lbs. (30 kg)
- Weight: 0.22 lb. (100 g)
- Bar opens: 65°, Handle 55°
- Spindle Supplied

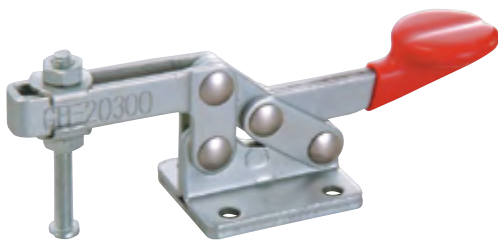

GH-20300

Model	A	B
GH-20300	0.20 (5)	0.35 (9)

UNIT: inch (metric mm)

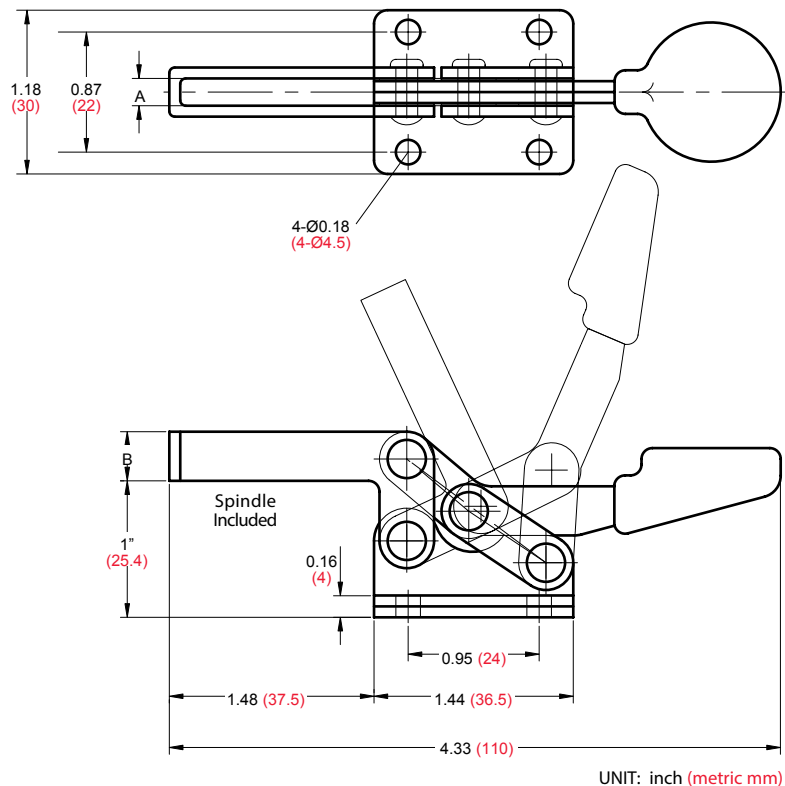

22100 & 22105

- Holding Capacity: 150 lbs. (68 kg)
- Weight: 0.24 lbs. (110 g)
- Bar opens: 90°, Handle 90°
- Spindle Supplied: GH-SA-14134

Almost identical to the 201-B model (pg 13).
Lighter and more affordable.



GH-22100

Model	A	B	C
All	0.25 (6.4)	0.50 (12.7)	0.25 (6.4)

UNIT: inch (metric mm)

Model	Description
GH-22100	Flanged Base
GH-22105	Straight Base

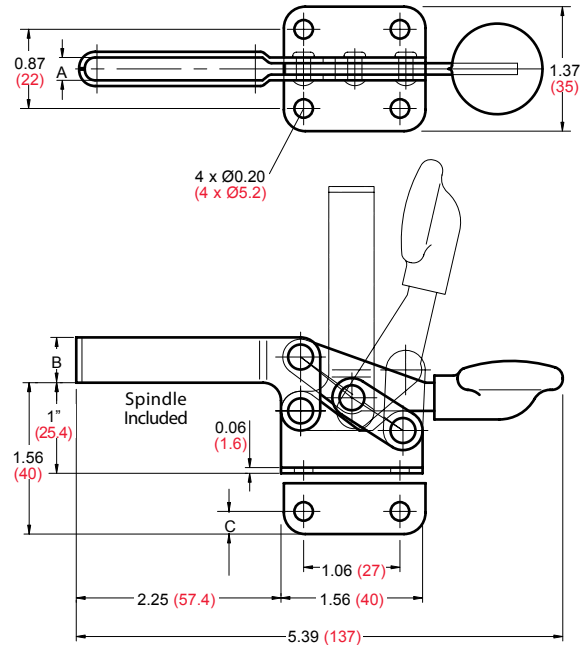

UNIT: inch (metric mm)

Series 20752-B

- Bar opens: 94°, Handle 76°
- Spindle Supplied.

The "hunch back" design leaves extra room for the fingers. All models have the red ribbed handles and come with hex bolt spindles.

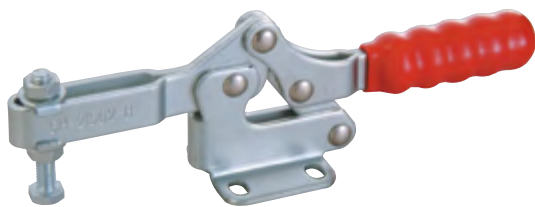

GH-21502-B

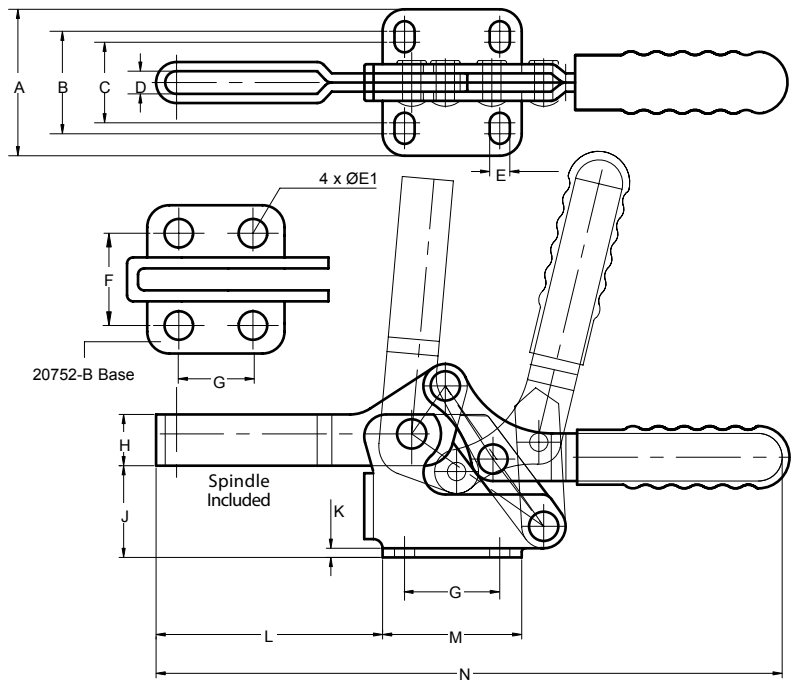

UNIT: inch (metric mm)

Model	Holding Capacity	A	B	C	D	E	ØE1	F	G	H	J	K	L	M	N	Weight
GH-20752-B	165 lbs. (75 kg)	1.06 (27)	-	-	0.23 (5.8)	-	0.20 (5.2)	0.66 (16.8)	0.53 (13.5)	0.37 (9.5)	0.75 (19)	0.08 (2)	1.46 (37)	1"	4.29 (109)	0.22 lb. (100 g)
GH-21502-B	330 lbs. (150 kg)	1.57 (40)	1.10 (28)	0.87 (22)	0.24 (6.2)	0.22 (5.5)	-	-	1.02 (26)	0.55 (14)	1"	0.10 (2.5)	2.44 (62)	1.50 (38)	6.73 (171)	0.50 lb. (230 g)
GH-22502-B	550 lbs. (250 kg)	1.85 (47)	1.22 (31)	1.02 (26)	0.35 (9)	0.26 (6.6)	-	-	1.02 (26)	0.69 (17.5)	1.34 (34)	0.12 (3)	3.11 (79)	1.65 (42)	8.62 (219)	0.95 lb. (430 g)

Series 201-B Popular!

- Cross Ref.: DE-STA-CO Series 215
- Holding Capacity: 200 lbs. (90 kg)
- Weight: 0.29 lb. (130 g)
- Bar opens: 85°, Handle 60°
- Spindle Supplied: GH-FC-14134



GH-201-B

Model	Description	A	ØB	C
GH-201-B	U-Bar, Flanged Base			
GH-201-BSS	Stainless Steel Model of GH-201-B			
GH-201-BI	U-Bar, Straight Base	0.45 (7.4)	0.28 (7.1)	0.16 (4)
GH-201-BS	Solid Bar, Flanged Base			
GH-201-BSI	Solid Bar, Straight Base			

UNIT: inch (metric mm)

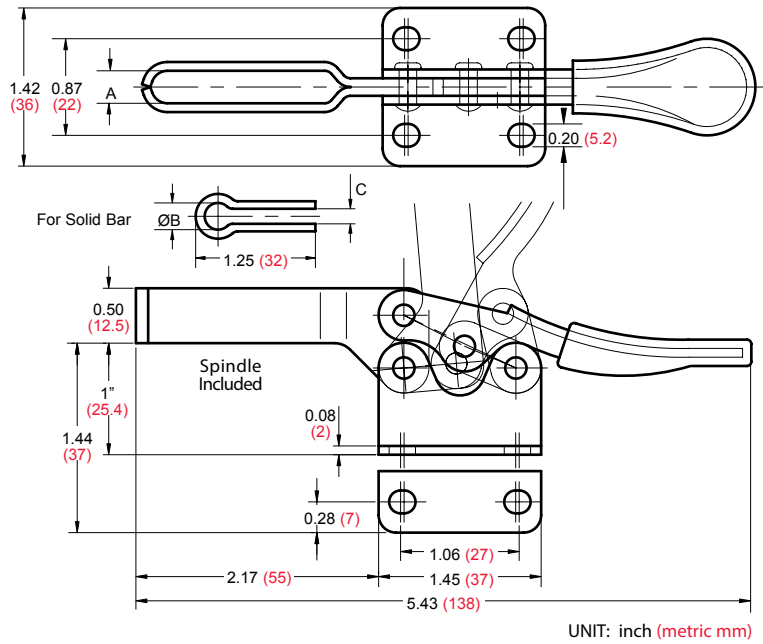

UNIT: inch (metric mm)

UNIQUE

201-BHB

- High Base Model of GH-201-B
- Weight: 0.32 lbs. (146 g)



GH-201-BHB

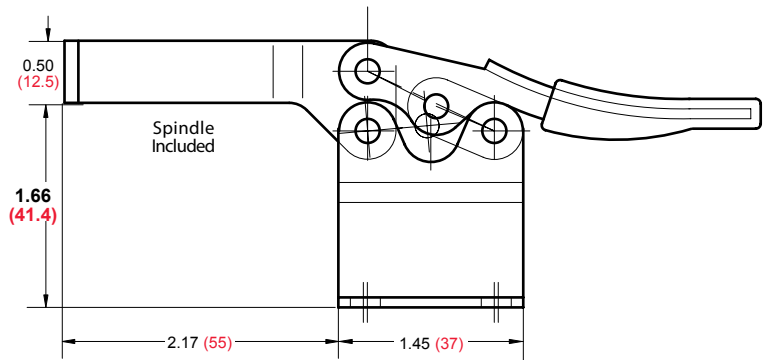

UNIT: inch (metric mm)

UNIQUE

201-BSM

- Side Mount Model of GH-201-B
- Weight: 0.36 lbs. (163 g)

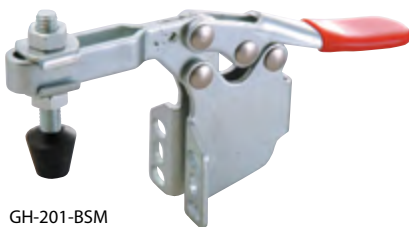

GH-201-BSM

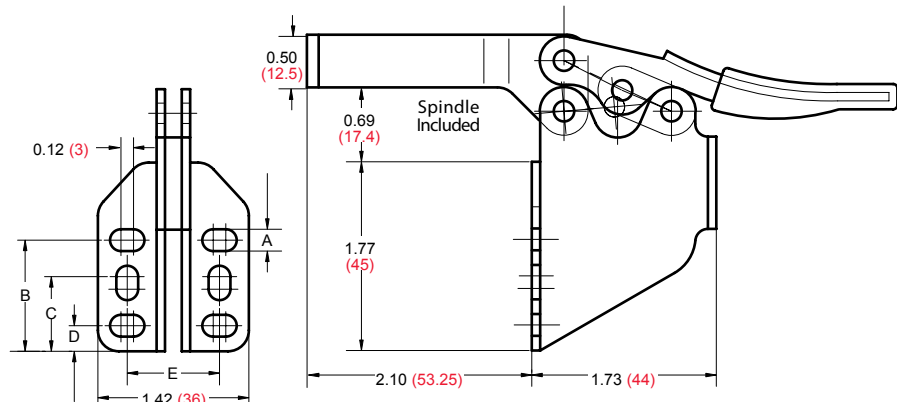

UNIT: inch (metric mm)

Model	A	B	C	D	E
All	0.20 (5.1)	1.04 (26.4)	0.70 (17.8)	0.24 (6.1)	0.87 (22.1)

UNIT: inch (metric mm)

20820

- Cross Ref.: DE-STA-CO Model 317-U
- Holding Capacity: 220 lbs. (100 kg)
- Weight: 0.88 lbs. (400 g)
- Bar opens: 185°, Handle 60°
- Spindle Supplied: GH-FC-56212

Mount vertically and horizontally



GH-20820

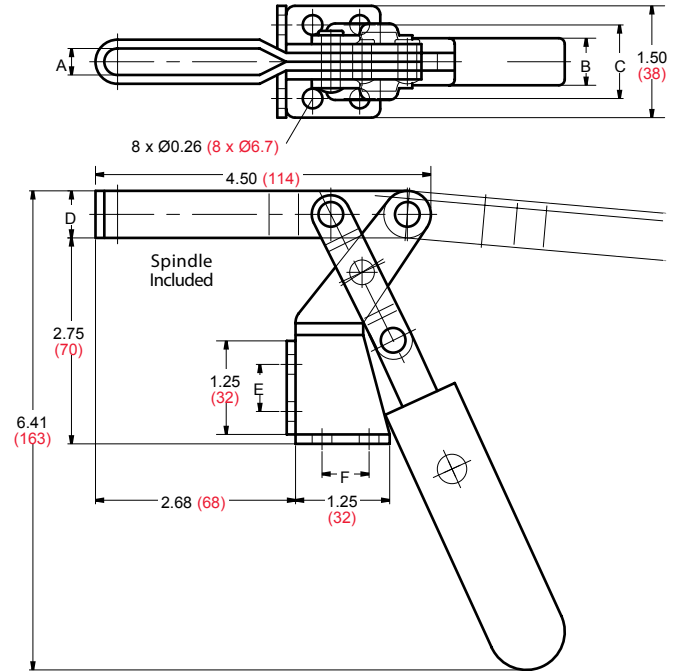

UNIT: inch (metric mm)

Model	A	B	C	D	E	F
GH-20820	0.35 (9)	0.63 (16)	1" (25.4)	0.63 (16)	0.63 (16)	0.63 (16)

UNIT: inch (metric mm)

Series 203-F & 202-F

- Holding Capacity: 500 lbs. (227 kg)
- Bar opens: 85°, Handle 58°
- Spindle Supplied: GH-FC-56212

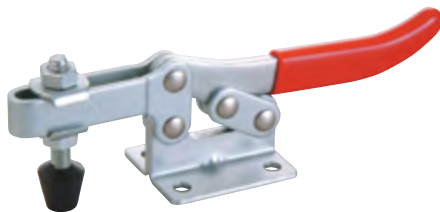

GH-203-F

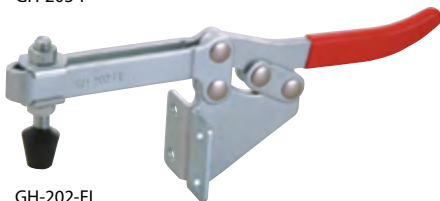

GH-202-FL

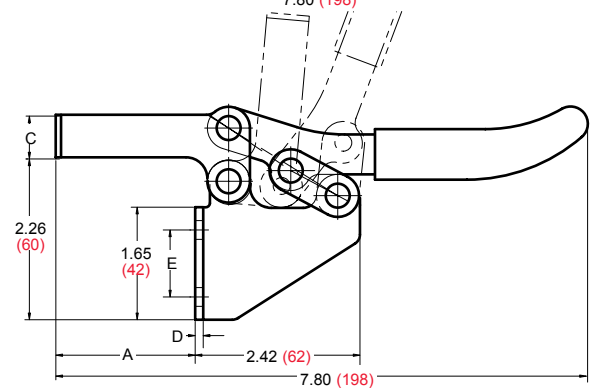
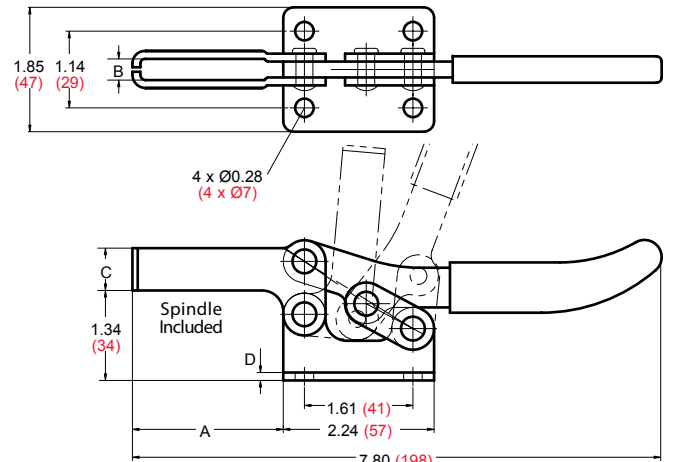

UNIT: inch (metric mm)

Model	Description	A	B	C	D	E	Weight
GH-203-F	U-Bar, Flanged Base	2.24 (57)	0.31 (8)	0.63 (16)	0.12 (3)	1" (25.4)	0.75 lb. (340 g)
GH-203-FL	Long U-Bar, Flanged Base	3.70 (94)					0.84 lb. (380 g)
GH-202-F	U-Bar, Side Mounted	2.05 (52)	0.31 (8)	0.63 (16)	0.12 (3)	1" (25.4)	0.85 lb. (385 g)
GH-202-FL	Long U-Bar, Side Mounted	3.50 (89)					0.94 lb. (425 g)

UNIT: inch (metric mm)

Series 225-D Popular!

- Cross Ref.: DE-STA-CO Series 225
- Holding Capacity: 500 lbs. (227 kg)
- Weight: 0.59 lbs. (265 g)
- Bar opens: 90°, Handle 65°
- Spindle Supplied: GH-FC-56212

This is the most popular horizontal handle toggle clamp. See Series GH-22165 for extra long U-Bars.



GH-225-D

Model	Description	A	B
GH-225-D	U-Bar, Flanged Base	0.33	0.25
GH-225-DSS	Stainless Steel Model of GH-225-D	(8.3)	(6.4)
GH-225-DI	U-Bar, Straight Base		

UNIT: inch (metric mm)

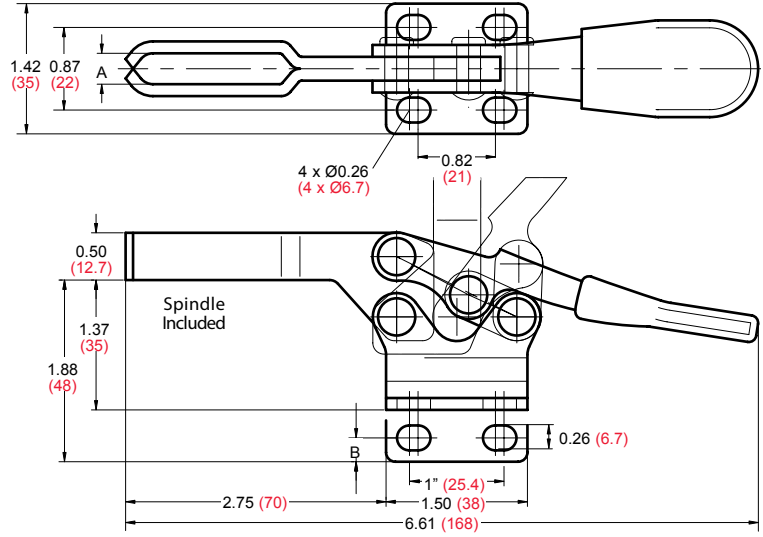

UNIT: inch (metric mm)

UNIQUE

225-DHB

- High Base Model of GH-201-B
- Weight: 0.63 lbs. (286 g)



GH-225-DHB

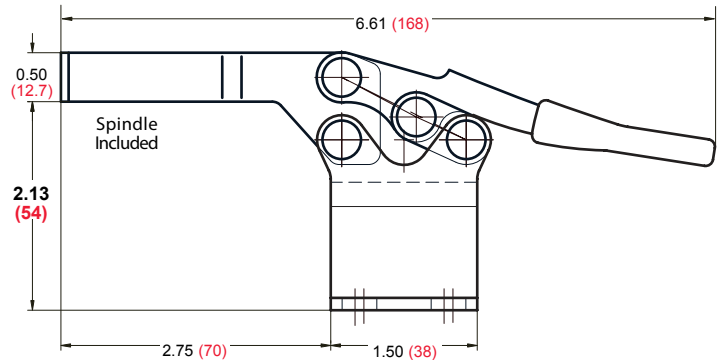

UNIT: inch (metric mm)

UNIQUE

225-DSM

- Side Mount Model of GH-201-B
- Weight: 0.69 lbs. (315 g)



GH-225-DSM

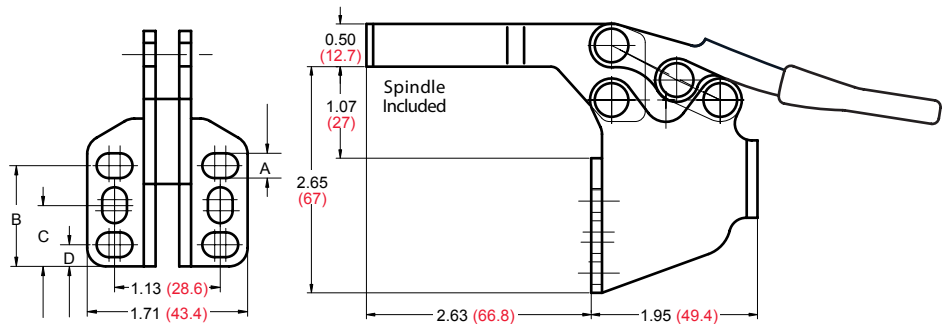

UNIT: inch (metric mm)

Model	A	B	C	D
All	0.26	1.07	0.65	0.23
	(6.7)	(27.3)	(17)	(5.9)

UNIT: inch (metric mm)

Series 22165

- Holding Capacity: 550 lbs. (250 kg)
- Bar opens: 96°, Handle 88°
- Spindle Supplied: GH-FC-56212

Expanded selection. Larger version of Series 225-D



GH-22165

Model	Description	A	B	C	D	Weight
GH-22165	Short U-Bar, Flanged Base	1.31 (33.3)	2.81 (71.4)	1.81 (46)	7.28 (185)	0.63 lb. (285 g)
GH-22170	Short U-Bar, Straight Base		2.99 (76)			0.66 lb. (300 g)
GH-22175	Short Solid Bar, Flanged Base		2.99 (76)			0.66 lb. (300 g)
GH-22180	Short Solid Bar, Straight Base	1.13 (28.7)	6.50 (165)	1.63 (41)	10.95 (278)	0.78 lb. (360 g)
GH-22185	Long U-Bar, Flanged Base		6.56 (167)			0.81 lb. (365 g)
GH-22190	Long U-Bar, Straight Base		6.56 (167)			0.81 lb. (365 g)
GH-22195	Long Solid Bar, Flanged Base		6.56 (167)			0.81 lb. (365 g)
GH-22200	Long Solid Bar, Straight Base	6.56 (167)	6.56 (167)	1.63 (41)	10.95 (278)	0.81 lb. (365 g)

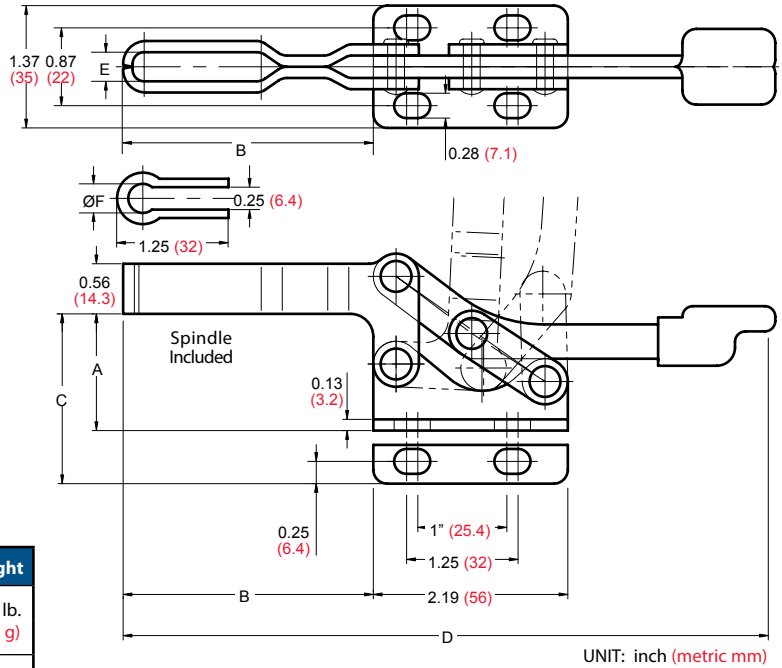

UNIT: inch (metric mm)

Model	E	ØF
All	0.33 (8.4)	0.33 (8.3)

UNIT: inch (metric mm)

21383

- Holding Capacity: 550 lbs. (250kg)
- Weight: 0.46 lb. (209 g)
- Bar opens: 72°, Handle 72°
- Spindle Supplied: GH-SA-56212

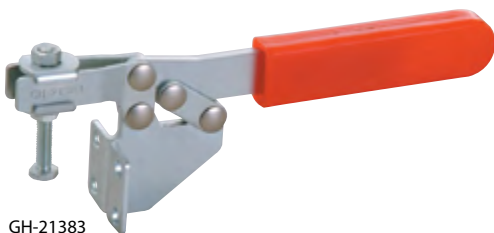

GH-21383

Model	A	B
GH-21383	0.37 (9.4)	0.55 (14)

UNIT: inch (metric mm)

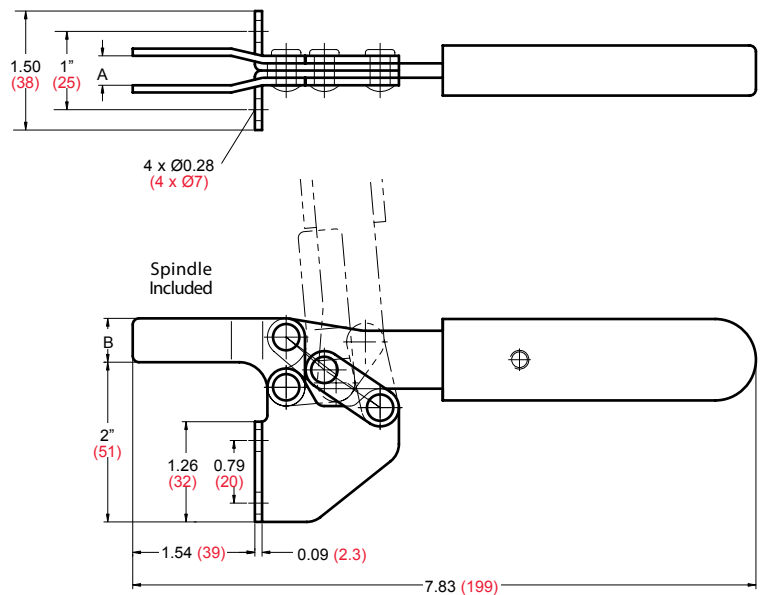

UNIT: inch (metric mm)

25383

- Holding Capacity: 600 lbs. (280 kg)
- Weight: 0.96 lb. (435 g)
- Bar opens: 80°, Handle 80°
- Spindle Supplied

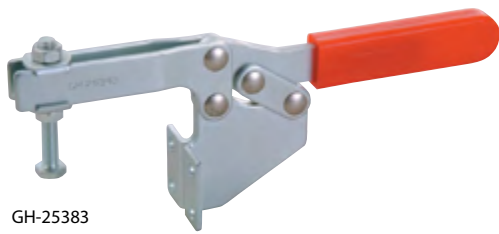

GH-25383

Model	A	B	C
GH-25383	0.43 (11)	0.79 (20)	0.12 (3)

UNIT: inch (metric mm)

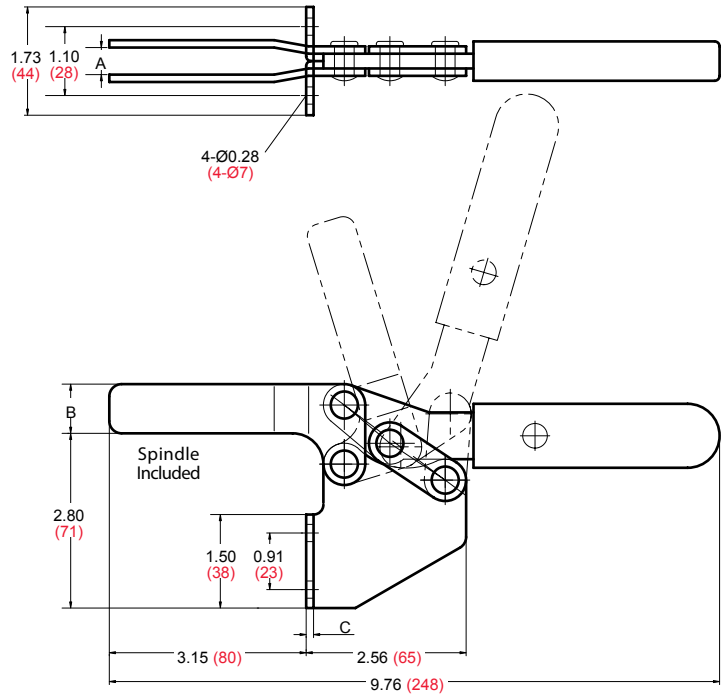

UNIT: inch (metric mm)

22235

- Holding Capacity: 600 lbs. (273 kg)
- Weight: 1.41 lbs. (640 g)
- Bar opens: 111°, Handle 94°
- Spindle Supplied: GH-FC-56212



GH-22235

Model	A	B	C
GH-22235	0.31 (8)	0.69 (17.5)	0.16 (4)

UNIT: inch (metric mm)

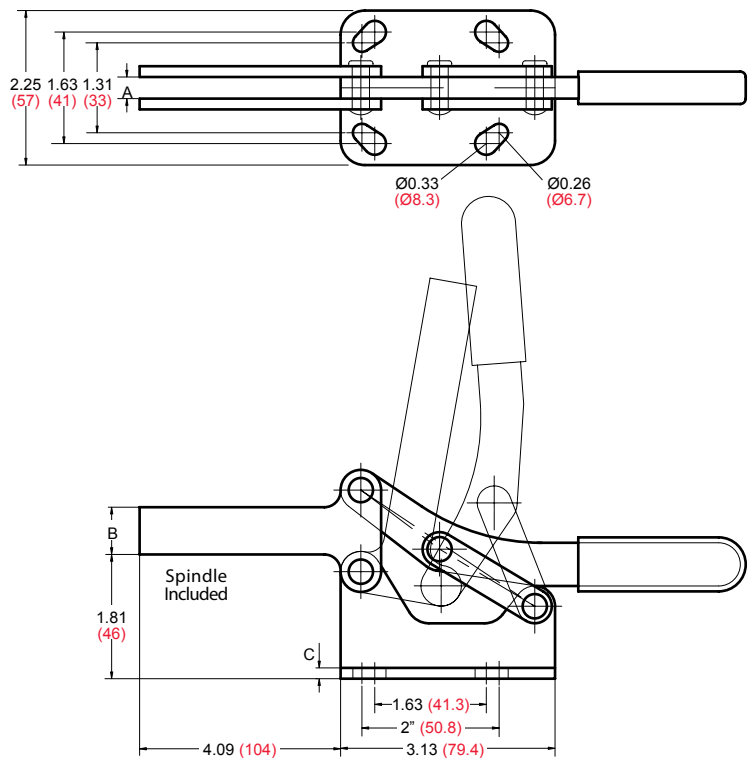

UNIT: inch (metric mm)

25382

- Holding Capacity: 620 lbs. (280 kg)
- Weight: 0.84 lb. (380 g)
- Bar opens: 80°, Handle 80°
- Spindle Supplied

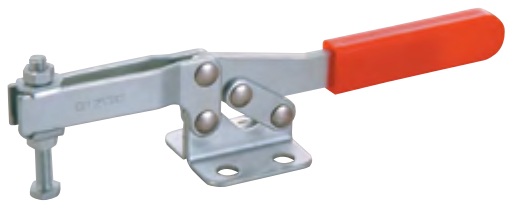

GH-25382

Model	A	B	C
GH-25382	0.47 (12)	0.79 (20)	1.18 (30)

UNIT: inch (metric mm)

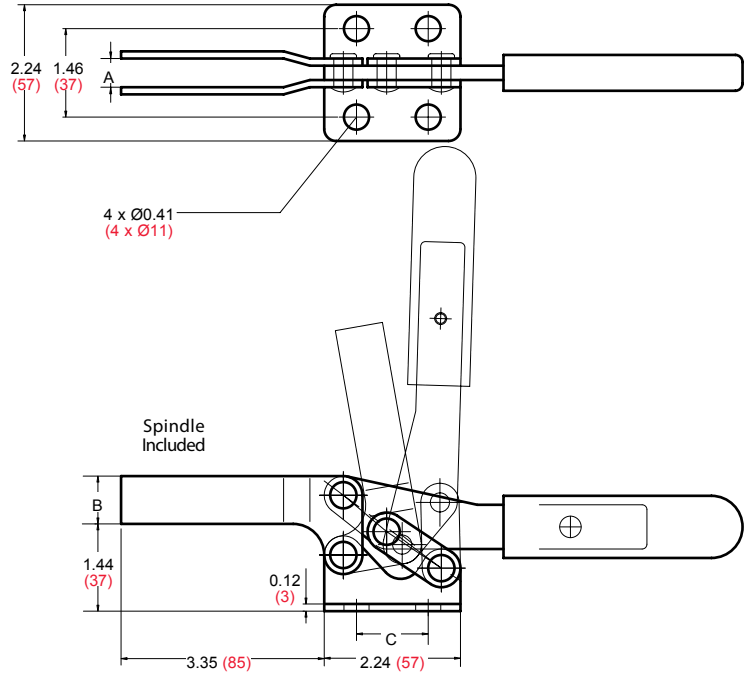

UNIT: inch (metric mm)

21385

- Holding Capacity: 660 lbs. (300 kg)
- Weight: 1.08 lb. (490 g)
- Bar opens: 80°, Handle 85°
- Spindle Supplied: GH-SA-38200

GH-21385 features an easy release lever.



GH-21385

Model	A	B	C
GH-21385	0.43 (11)	0.79 (20)	1.46 (34)

UNIT: inch (metric mm)

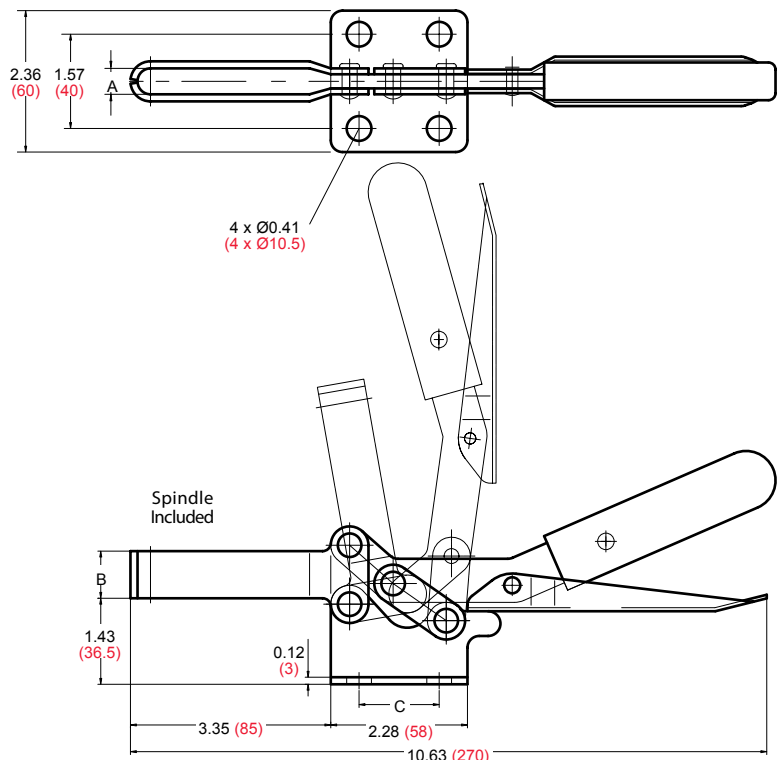

UNIT: inch (metric mm)

Series 20235

- Holding Capacity: 750 lbs. (340 kg)
- Weight: 1.41 lbs. (640 g)
- Bar opens: 85°, Handle 50°
- Spindle Supplied: GH-FC-38312



GH-20235

Model	Description	A	B	C
GH-20235	U-Bar, Flanged Base	0.43	0.75	0.16
GH-20235-SS	Stainless Steel Model of GH-20235	(11)	(19)	(4)
GH-20236	U-Bar, Straight Base			

UNIT: inch (metric mm)

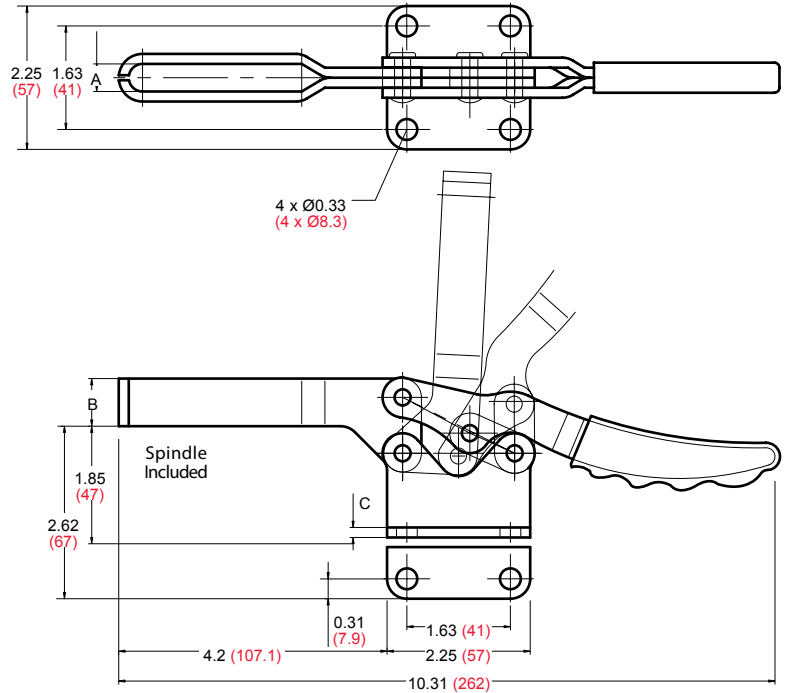

UNIT: inch (metric mm)

Series 200-W

- Holding Capacity: 880 lbs. (400 kg)
- Bar opens: 84°, Handle 85°

Woodworking models

These clamps have an extra high and long spindle bar. The 220-WH and 220-WLH have an extra lever to increase clamping leverage.



GH-200-W



GH-200-WLH

Model	Spindle	A	B	C	D	E	Weight
GH-200-W	GH-FC-38312	2.13 (54)	2.36 (60)	9.45 (240)			1.32 lbs. (600 g)
GH-200-WL			4.33 (110)	11.42 (290)			1.41 lbs. (640 g)
GH-200-WH	GH-FC-38412	3.11 (79)	2.36 (60)	9.45 (240)	0.50 (12.6)	0.81 (20.5)	1.54 lbs. (700 g)
GH-200-WLH			4.33 (110)	11.42 (290)			1.64 lbs. (745 g)
GH-220-WH			2.36 (60)	9.45 (240)			1.74 lbs. (790 g)
GH-220-WLH			4.33 (110)	11.42 (290)			1.83 lbs. (830 g)

UNIT: inch (metric mm)

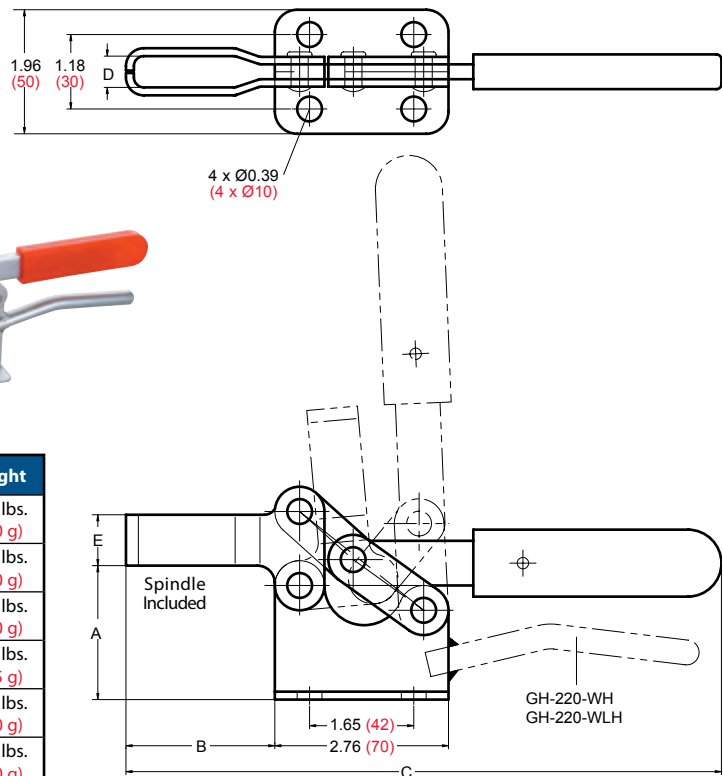

UNIT: inch (metric mm)

Series 204-GB

- Holding Capacity: 1,400 lbs. (630 kg)
- Bar opens: 91°, Handle 94°
- Spindle Supplied: GH-SA-12300

This clamp is based on the GH-204-G design, without the cast iron base.

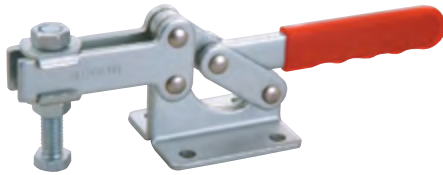

GH-204-GB



GH-204-GBLH

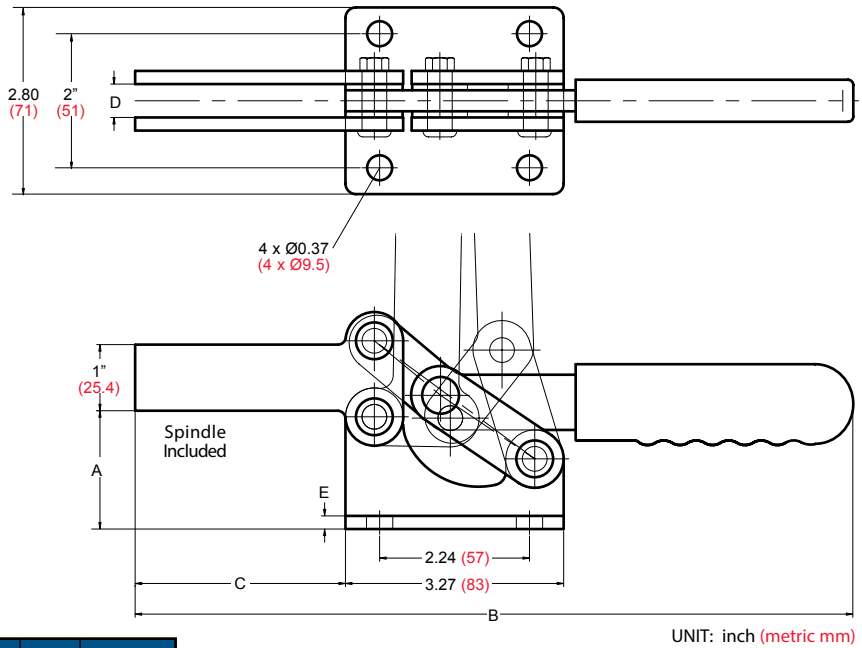

Model	Description	A	B	C	D	E	Weight
GH-204-GB	Short Bar, Low Base	1.77 (45)	10.59 (269)	3.15 (80)			2.60 lbs. (1,180 g)
GH-204-GBL	Long Bar, Low Base	1.77 (45)	12.44 (316)	5" (127)	0.50 (12.7)	0.24 (6)	2.78 lbs. (1,260 g)
GH-204-GBLH	Long Bar, High Base	2.79 (71)	12.44 (316)	5" (127)			3.23 lbs. (1,465 g)

UNIT: inch (metric mm)

Series 204-G

- Holding Capacity: 1,400 lbs. (636 kg)
- Weight: 2.69 lbs. (1,220 g)
- Bar opens: 91°, Handle 94°
- Spindle Supplied: GH-SA-12300

Heavy Duty Model

This clamp has five mounting holes on the cast iron base. Constructed with extra thick plate stock with hardened ground pins and bushings for smooth action and long life.

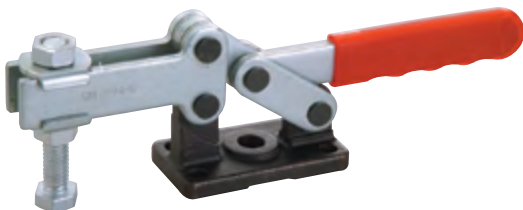

GH-204-G

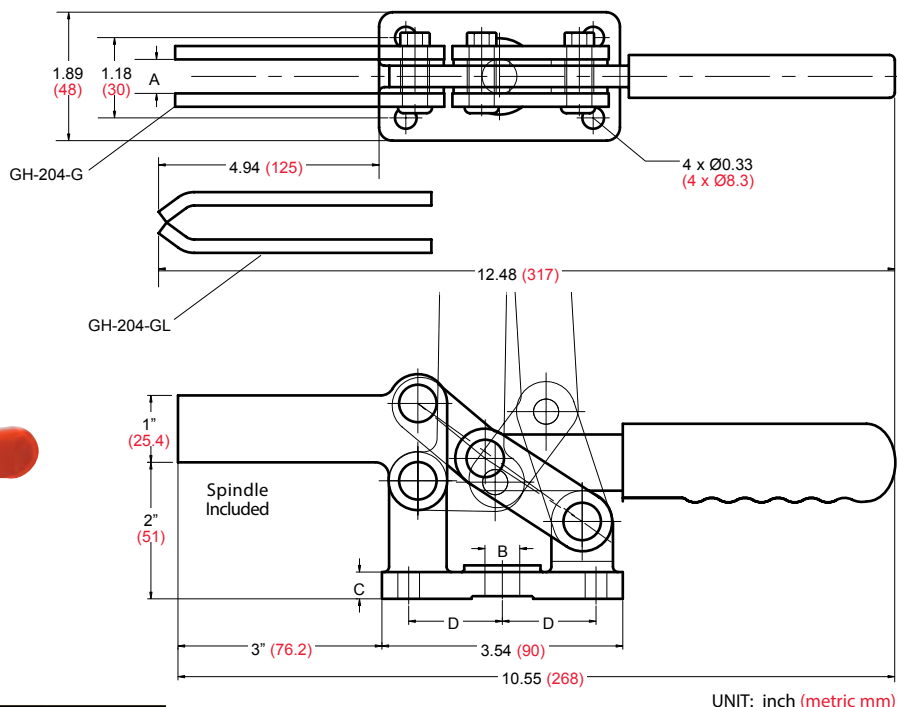

Model	Description	A	B	C	D
GH-204-G	Open Bar, Ductile Iron Base	0.50 (12.7)	0.50 (13)	0.39 (10)	1.38 (35)
GH-204-GL	Long Closed Bar, Ductile Iron Base				

UNIT: inch (metric mm)

301-A & 301-B

- Cross Ref.: DE-STA-CO Model 601
- Holding Capacity: 100 lbs. (45 kg)
- Weight: 0.11 lb. (50 g)
- Handle opens: 190°
- Plunger stroke: 0.63" (15.9 mm)
- Spindle supplied: GH-SA-08034 (Nylon)

Economical, miniature push-pull clamp with long plunger stroke.

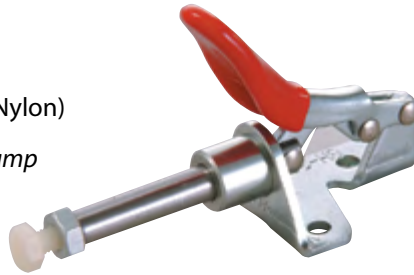

GH-301-A

Model	Description	A	B	C	D
GH-301-A	8-32 Thread	0.25 (6.4)	0.63 (15.9)	0.39 (10)	0.50 (12.7)
GH-301-B	1/4-20 Thread				

UNIT: inch (metric mm)

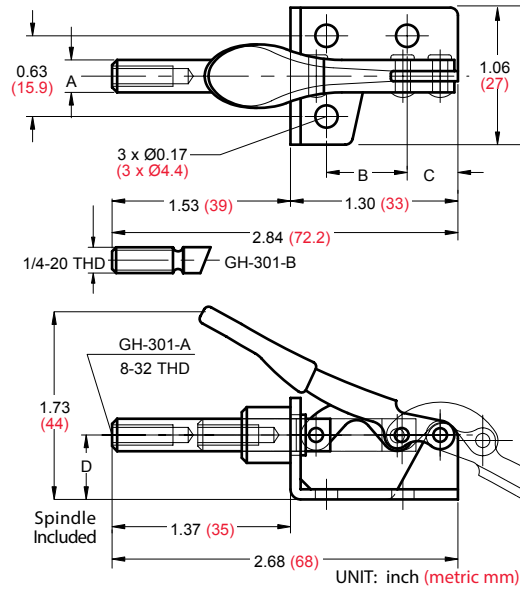

36006

- Holding Capacity: 110 lbs. (50 kg)
- Weight: 0.15 lb. (70 g)
- Handle opens: 93°
- Plunger stroke: 0.43" (11 mm)
- Spindle supplied

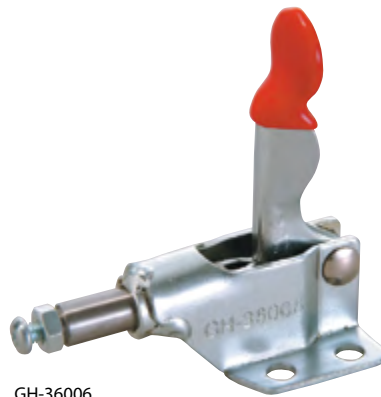

GH-36006

Model	A	B	C	D	E	F	G
GH-36006	0.59 (15)	0.85 (21.6)	0.06 (1.6)	0.39 (10)	0.55 (14)	0.75 (19)	0.59 (15)

UNIT: inch (metric mm)

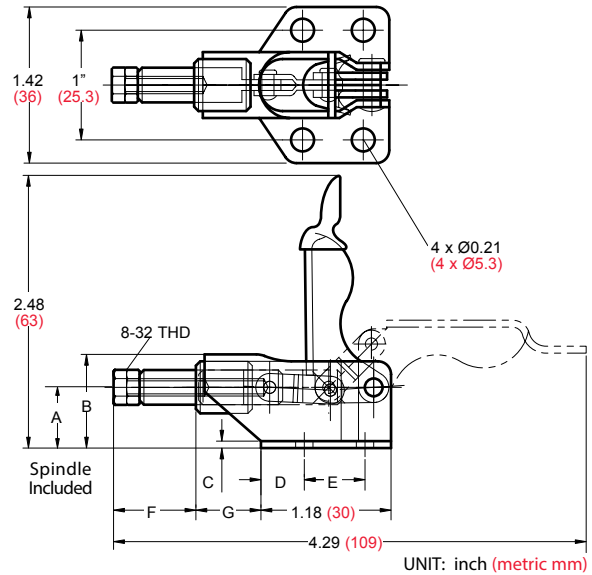

UNIQUE

36070 REVERSE ACTION

- Holding Capacity: 110 lbs. (50kg)
- Weight: 0.22 lb. (100 g)
- Handle opens: 66°
- Plunger stroke: 0.39" (10mm)
- Spindle supplied



GH-36070

Model	ØA	B	C	ØD	E	F	G
GH-36070	0.32 (8)	0.30 (7.5)	0.71 (18)	0.20 (5.2)	0.50 (12.7)	0.50 (112.7)	0.94 (24)

UNIT: inch (metric mm)

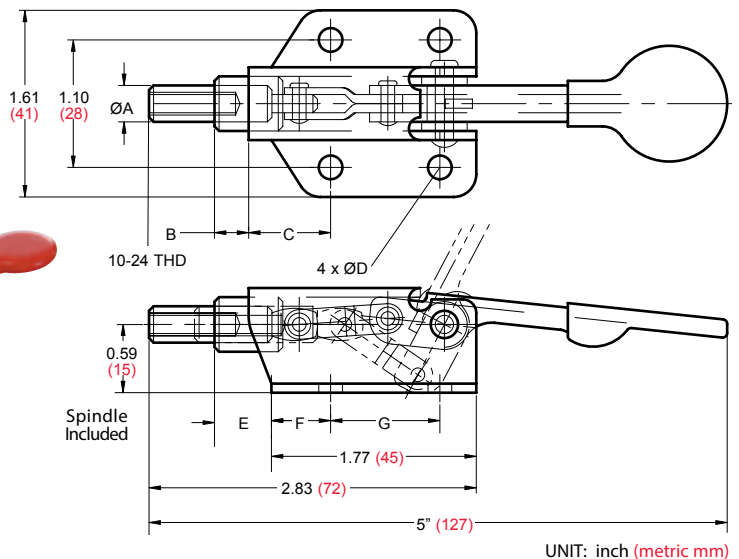

302-F & 302-FSS Popular!

- Cross Ref.: DE-STA-CO Model 605
- Holding Capacity: 300 lbs. (136 kg)
- Weight: 0.66 lb. (300 g)
- Handle opens: 180°
- Plunger stroke: 1.25" (32 mm)
- Spindle supplied: GH-SA-56200
- **Stainless Steel** model GH-302-FSS available

The best selling mid-size push-pull clamp. Accepts all 5/16-18 spindles.

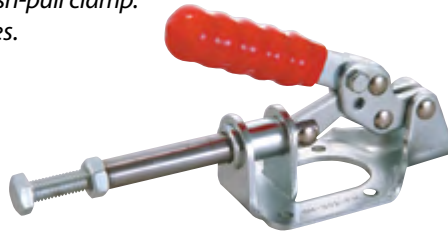

GH-302-F

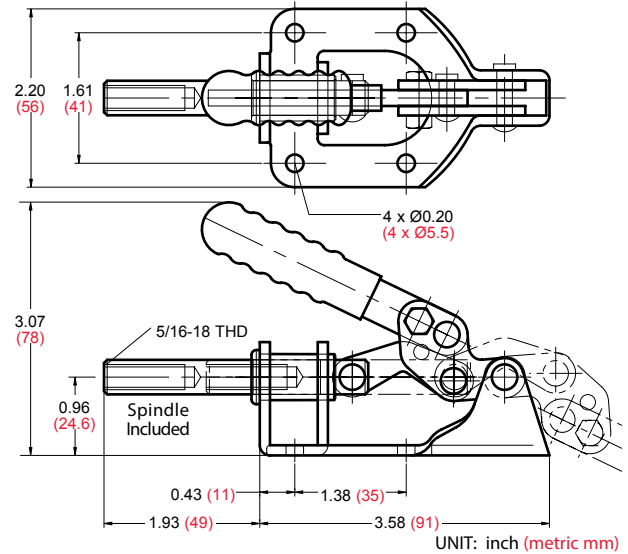

UNIT: inch (metric mm)

UNIQUE

302-D & 30282 REVERSE ACTION

- Holding Capacity: 350 lbs. (160 kg)
- Weight: 1.00 lb. (454 g)
- Handle opens: 45°
- Plunger stroke: 0.47" (12 mm)
- **Stainless Steel** model GH-302-FSS available

Plunger locks in extended position only.

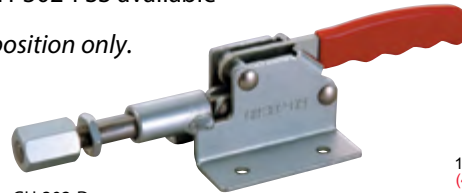

GH-302-D

Model	Description	A	B
GH-302-D	Flanged Base	0.12	0.41
GH-30282	Straight Base	(3)	(10.5)

UNIT: inch (metric mm)

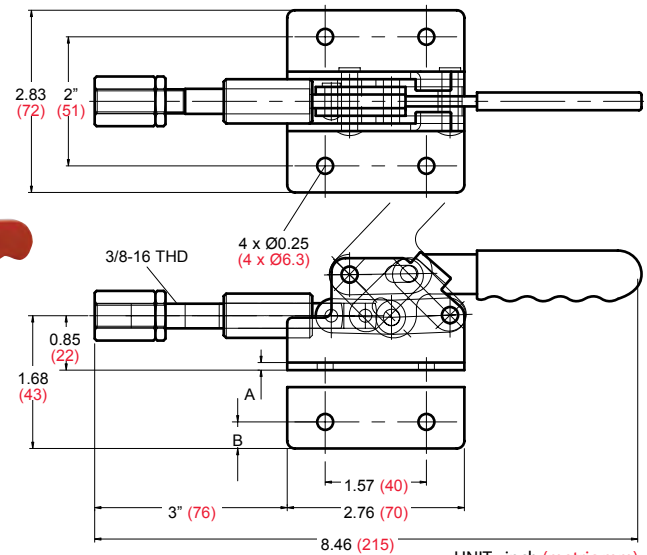

UNIT: inch (metric mm)

36092

- Cross Ref.: DE-STA-CO Model 609
- Holding Capacity: 400 lbs. (180 kg)
- Weight: 0.85 lb. (397 g)
- Handle opens: 180°
- Plunger stroke: 1.25" (31.8 mm)
- Spindle supplied: GH-SA-56200
- Accepts all 5/16-18 diameter spindles

Similar to GH-302-F. Addition of safety pins minimizes finger pinch.



GH-36092

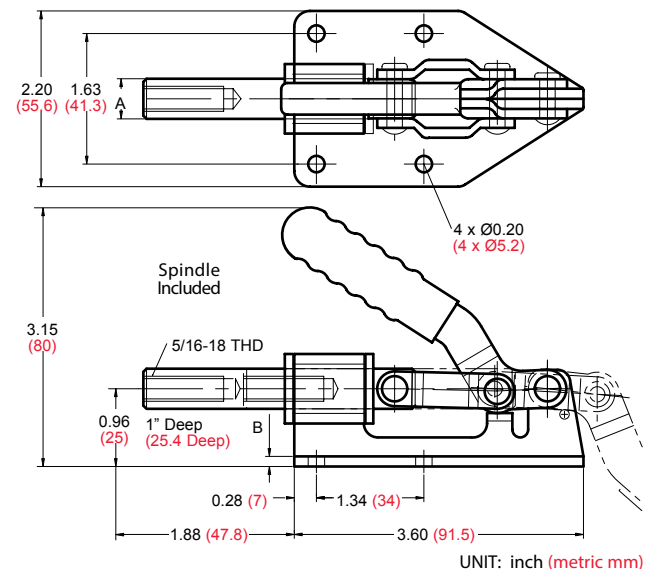

UNIT: inch (metric mm)

Model	ØA	B
GH-36092	0.50 (12.7)	0.13 (3.2)

UNIT: inch (metric mm)

36020

- Holding Capacity: 400 lbs. (180 kg)
- Weight: 0.76 lb. (345 g)
- Handle opens: 145°
- Plunger stroke: 1.18" (30 mm)
- Spindle supplied: GH-SA-56200
- Accepts all 5/16-18 diameter spindles

Model	ØA	B	C
GH-36020	0.47 (12)	0.12 (3)	0.31 (8)

UNIT: inch (metric mm)

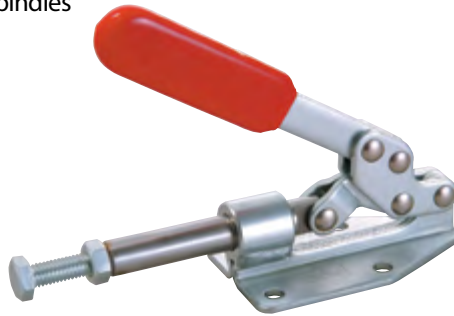

GH-36020

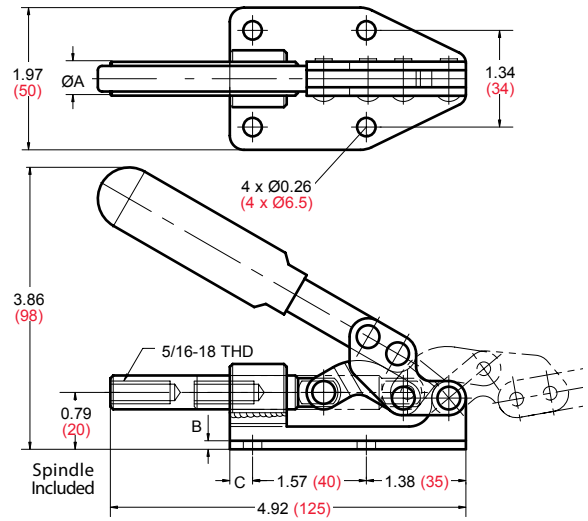

UNIT: inch (metric mm)

36003

- Cross Ref.: DE-STA-CO Model 603
- Holding Capacity: 600 lbs. (272 kg)
- Weight: 0.78 lb. (355 g)
- Handle opens: 180°
- Plunger stroke: 1.25" (31.8 mm)
- Spindle supplied: GH-SA-56200
- Accepts all 5/16-18 diameter spindles

This clamp has a forged alloy steel base, and lower profile handle.

Model	ØA	B	C	D
GH-36003	0.44 (11.1)	1.25 (31.8)	1" (25.4)	0.19 (4.8)

UNIT: inch (metric mm)

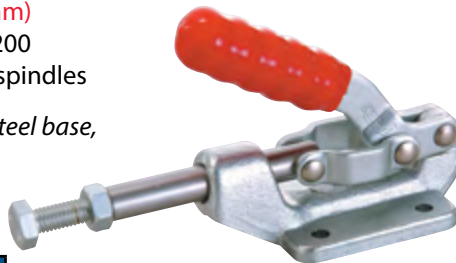

GH-36003

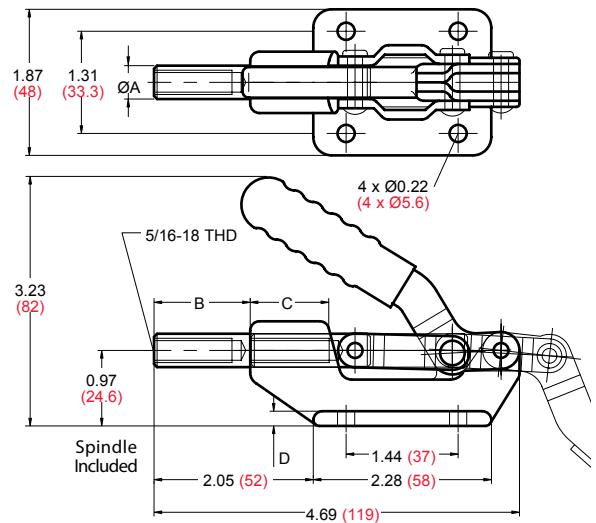

UNIT: inch (metric mm)

UNIQUE

30290 & 30292 REVERSE ACTION

- Holding Capacity: 650 lbs. (295 kg)
- Weight: 2.80 lb. (1270 g)
- Handle opens: 45°
- Plunger stroke: 0.91" (23 mm)

Plunger locks in extended position only.



GH-30290

Model	Description	A	B	C	D
GH-30290	Flanged Base	0.94 (24)	0.18 (4.5)	0.48 (12.2)	1.97 (50)
GH-30292	Straight Base				

UNIT: inch (metric mm)

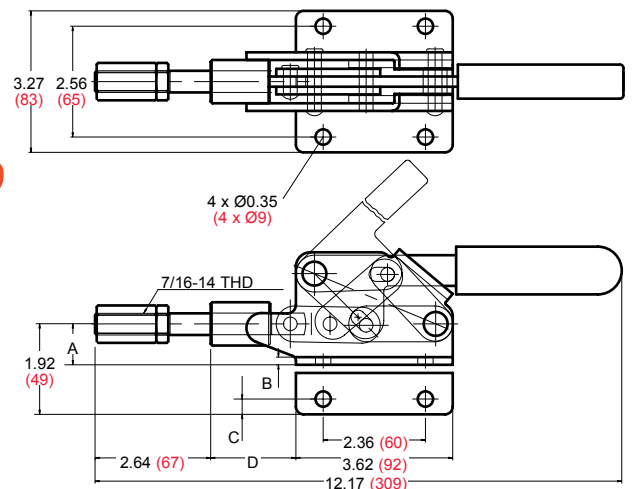

UNIT: inch (metric mm)

UNIQUE

36060 REVERSE ACTION

- Cross Ref.: DE-STA-CO Model 620
- Holding Capacity: 660 lbs. (300 kg)
- Weight: 1.36 lb. (615 g)
- Handle opens: 76°
- Plunger stroke: 1.10" (28 mm)
- Spindle supplied
- Accepts all 5/16-18 diameter spindles

Plunger locks in extended position only.

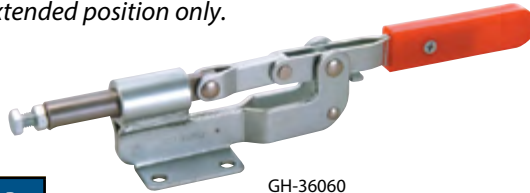

GH-36060

Model	ØA	B
GH-36060	0.13 (3.2)	0.35 (9)

UNIT: inch (metric mm)

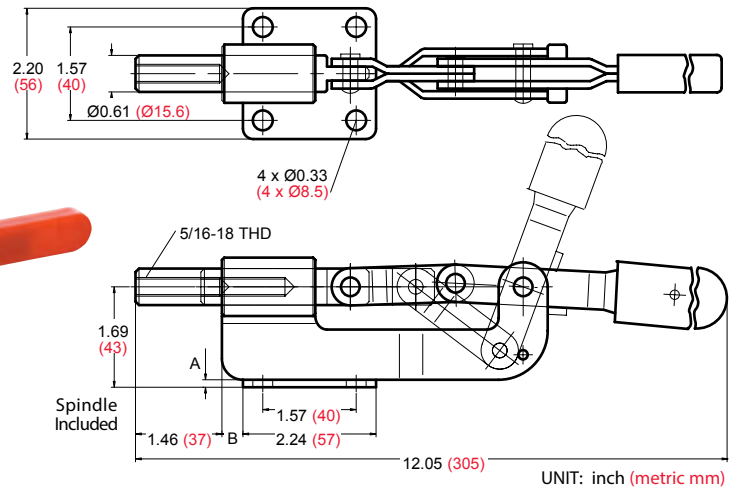

UNIT: inch (metric mm)

30607 LOW PROFILE

- Cross Ref.: DE-STA-CO Model 607
- Holding Capacity: 700 lbs. (318 kg)
- Weight: 1.54 lb. (700 g)
- Handle opens: 180°
- Plunger stroke: 1.63" (41.3 mm)
- Spindle supplied: GH-SA-56200
- Accepts all 5/16-18 diameter spindles

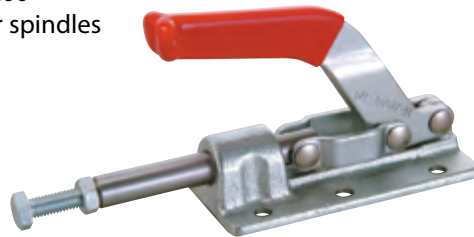

GH-30607

Model	A	B	C
GH-30607	0.69 (17.5)	0.19 (4.8)	0.63 (16)

UNIT: inch (metric mm)

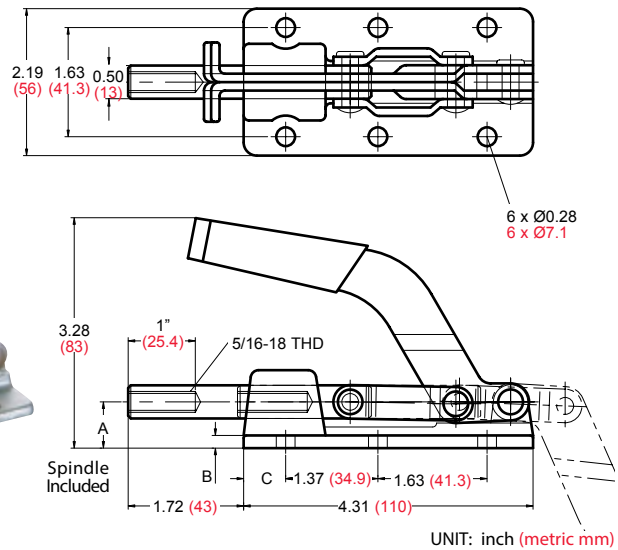

UNIT: inch (metric mm)

36010 & 36012

- Cross Ref.: DE-STA-CO Model 610, 618
- Holding Capacity: 800 lbs. (364 kg)
- Weight: 1.76 lb. (800 g)
- Handle opens: 180°
- Plunger stroke: 1.63" (41.3 mm)
- Spindle supplied: GH-SA-38300
- Accepts all 3/8-16 diameter spindles

Constructed with heavy gage sheet metal, this is an economical long stroke push-pull clamp.

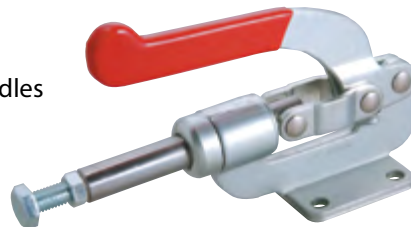

GH-36010

Model	Description	A	B	ØC
GH-36010	Flanged Base	0.25	0.31	0.62
GH-36012	Straight Base	(6.4)	(8)	(15.7)

UNIT: inch (metric mm)

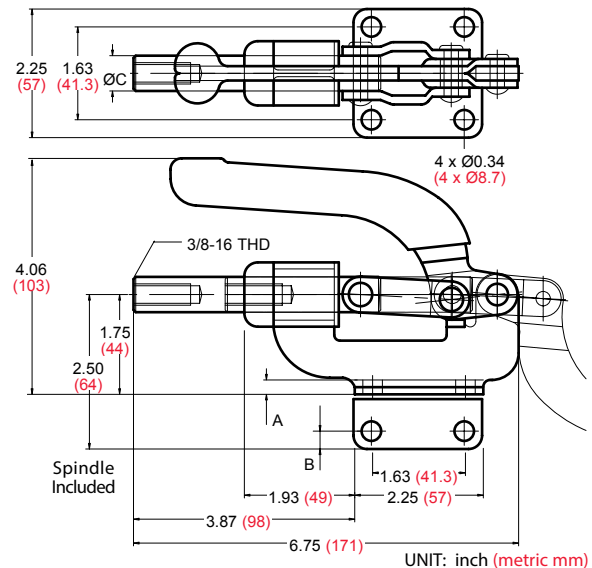

UNIT: inch (metric mm)

303-EK

- Holding Capacity: 1,000 lbs. (454 kg)
- Weight: 2.13 lb. (965 g)
- Handle opens: 190°
- Plunger stroke: 1.97" (50 mm)

This clamp has a key way to keep the plunger from rotating.



GH-303-EK

Model	A	B	C
GH-303-EK	1 (25.4)	1.81 (46)	0.16 (4)

UNIT: inch (metric mm)

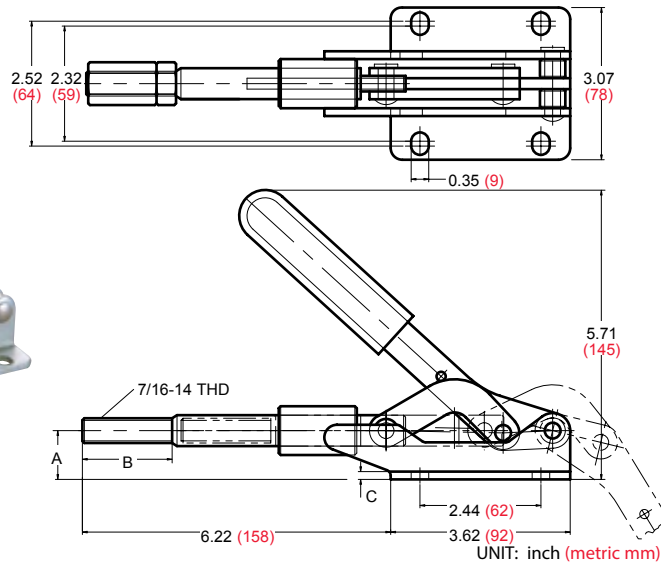

36330

- Cross Ref.: DE-STA-CO Model 630
- Holding Capacity: 2,500 lbs. (1135 kg)
- Weight: 2.06 lb. (935 g)
- Handle opens: 180°
- Plunger stroke: 2" (50.8 mm)
- Spindle supplied
- Accepts all 3/8-16 diameter spindles

This heavy duty clamp has a forged alloy steel base.



GH-36330

Model	ØA	B	C	D	E
GH-36330	0.62 (15.8)	1.25 (31.8)	0.81 (20.6)	0.20 (5)	0.50 (12.7)

UNIT: inch (metric mm)

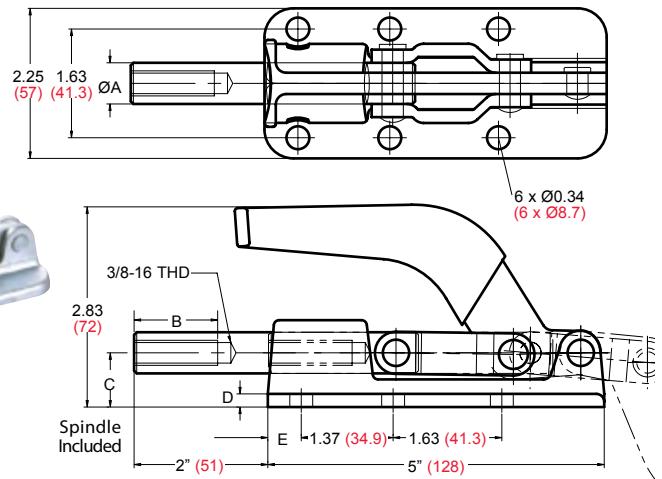

UNIQUE

30250 & 30450

This push-pull clamp has a small, special space-saving base that easily detaches for reverse positioning. Spindle Supplied.



GH-30450

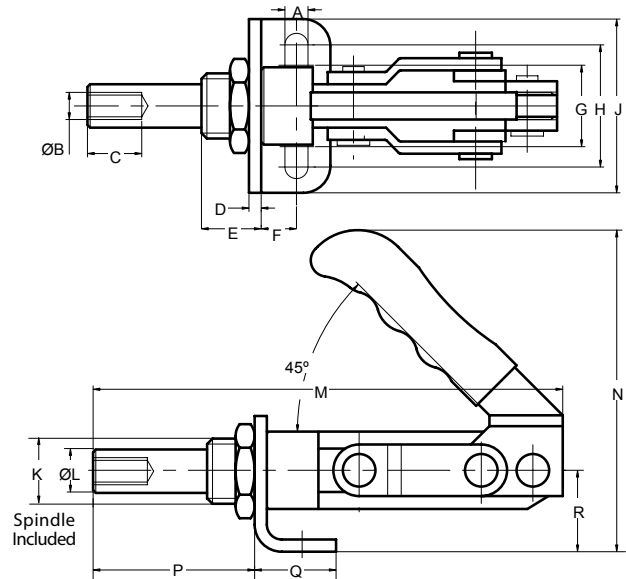

Model	Holding Capacity	Handle Opens	Plunger Stroke	A	ØB	C	D	E	F	G	H	J	K	ØL	M	N	P	Q	R	Weight
GH-30250	550 lbs. (250 kg)	190°	1.26 (32)	0.26 (6.5)	1/4-20 (M6x1)	0.47 (12)	0.16 (4)	0.67 (17)	0.39 (10)	1.18 (30)	1.65 (42)	2.24 (57)	1/4-20	0.43 (11)	5.35 (136)	3.35 (85)	2" (51)	0.91 (23)	0.98 (25)	0.85 lb. (385 g)
GH-30450	990 lbs. (450kg)	185°	1.50 (38)	0.33 (8.5)	3/8-16 (M10x1.5)	0.79 (20)	0.18 (4.5)	0.87 (22)	0.51 (13)	1.18 (30)	1.77 (45)	2.52 (64)	3/8-16	0.63 (16)	6.81 (173)	4.72 (120)	2.34 (60)	1.18 (30)	1.18 (30)	1.70 lbs. (774 g)

UNIT: inch (metric mm)

Series 36202

· Supplied with jam nut on the work side

All three of these plunger type push/pull clamps have threaded collars for mounting in threaded, or through holes. All clamps are supplied with thin lock nuts. Threaded mounting plates and brackets are also available as options.



GH-36205

GH-36225

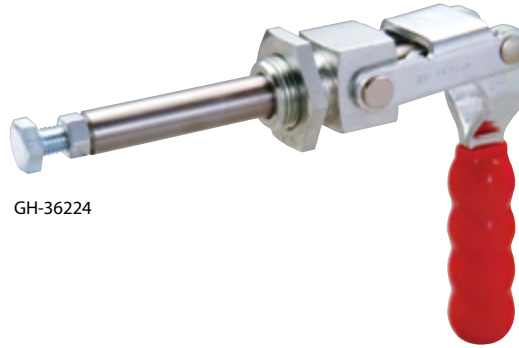

GH-36224

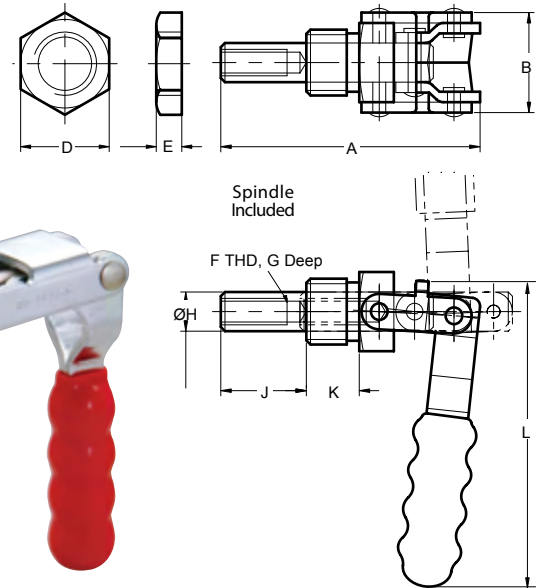

Model	Description
GH-36205	Mounting Plate for GH-36204
GH-36225	Mounting Plate for GH-36224

Model	Cross Ref. DE-STA-CO	Holding Capacity	Spindle Supplied	Plunger Stroke	A	B	D	E	F	G	ØH	J	K	L	Weight
GH-36202	602	200 lbs. (91 kg)	GH-SA-14112	0.75 (19)	2.48 (63)	0.95 (24)	0.91 (23)	0.25 (6.4)	1/4-20	0.62 (15.8)	0.37 (9.4)	0.81 (20.6)	0.50 (12.7)	2.96 (75)	0.25 lb. (113 g)
GH-36204	604	300 lbs. (136 kg)	GH-SA-56200	1.50 (38)	4.53 (115)	1.22 (31)	1.18 (30)	0.25 (6.4)	5/16-18	1" (25.4)	0.43 (11)	1.56 (39.7)	0.63 (16)	3.86 (98)	0.60 lb. (270 g)
GH-36204-SS	604-SS	Stainless Steel Model of GH-36204													
GH-36224	624	700 lbs. (318 kg)	GH-SA-38300	2.63 (66.8)	6.67 (170)	1.54 (39)	1.61 (41)	0.25 (6.4)	3/8-16	1.25 (31.8)	0.62 (15.8)	2.72 (69)	0.87 (22)	5.39 (137)	1.52 lbs. (690 g)

UNIT: inch (metric mm)

Series 304 & 305

All six of these push/pull clamps have a ductile iron base for close fit machining, strength and durability. All the shafts are ground to fit the reamed hole, so the plunger can be used for locating purposes as well as clamping. The plunger locks in both forward and retracted positions. The H model clamps are made with hardened pins and bushings for durability.

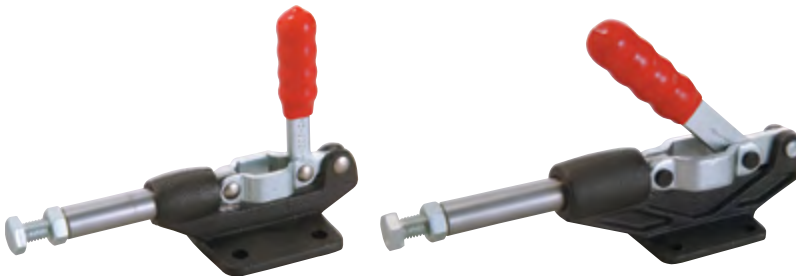

GH-305-C

GH-304-H

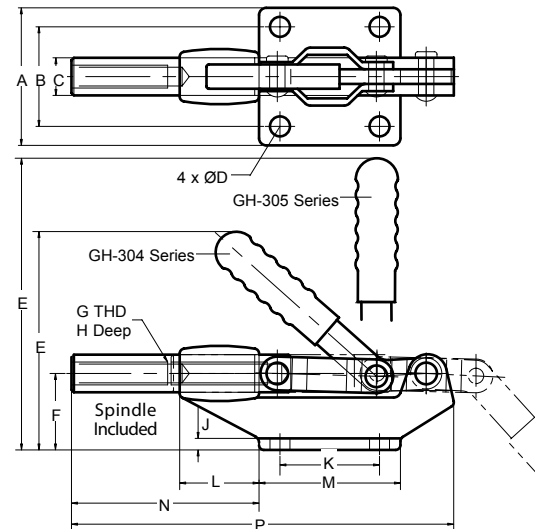

Model	Description	Holding Capacity	Spindle Supplied	Plunger Stroke	A	B	ØC	ØD	E	F	G	H	J	K	L	M	N	P	Weight
GH-304-C	45° Handle	500 lbs. (227 kg)	GH-SA-56200	1.26 (32)	2.25 (57.2)	1.62 (41.1)	0.50 (12.7)	0.26 (6.7)	2.94 (75)	1"	5/16-18	1.19 (30.2)	0.19 (4.8)	1.38 (35)	0.81 (20.6)	2.06 (52.4)	2.06 (52.4)	4.94 (125)	0.75 lb. (340 g)
GH-305-C	90° Handle	500 lbs. (227 kg)							3.56 (91)										0.75 lb. (340 g)
GH-304-E	45° Handle	850 lbs. (386 kg)	GH-SA-38300	1.65 (42)	2.25 (57.2)	1.62 (41.1)	0.63 (16)	0.33 (8.3)	3.87 (98)	1.25	3/8-16	1.54 (39.2)	0.19 (4.8)	1.62 (41.1)	1.25 (31.8)	2.31 (58.8)	3.19 (81)	6.25 (159)	1.28 lbs. (580 g)
GH-305-E	90° Handle	850 lbs. (386 kg)							4.83 (123)										1.28 lbs. (580 g)
GH-304-H	45° Handle	1,500 lbs. (680 kg)	GH-SA-12300	2.36 (60)	2.81 (71.4)	2" (50.8)	0.76 (19.2)	0.33 (8.3)	5.25 (133)	1.75	1/2-13	1.94 (49.2)	0.25 (6.4)	2" (50.8)	2" (50.8)	2.88 (73.2)	4.76 (121)	9.38 (238)	3.26 lbs. (1,480 g)
GH-305-H	90° Handle	1,500 lbs. (680 kg)							6.76 (172)										3.26 lbs. (1,480 g)

UNIT: inch (metric mm)

27 Heavy Duty Models

- High strength steel construction, broached body and precise ground plunger.
- Hardened steel pins and bushings are used for pivot joints.
- Supplied with separate handle and base. Users can weld them at desired position.
- These clamps can be mounted using base (supplied) or by drilling a hole in fixture and welding in place.
- Clamp handle can be rotated to any position.

30509 & 30609

Compact design with maximum plunger travel. Plunger locks in extended position only.



GH-30509

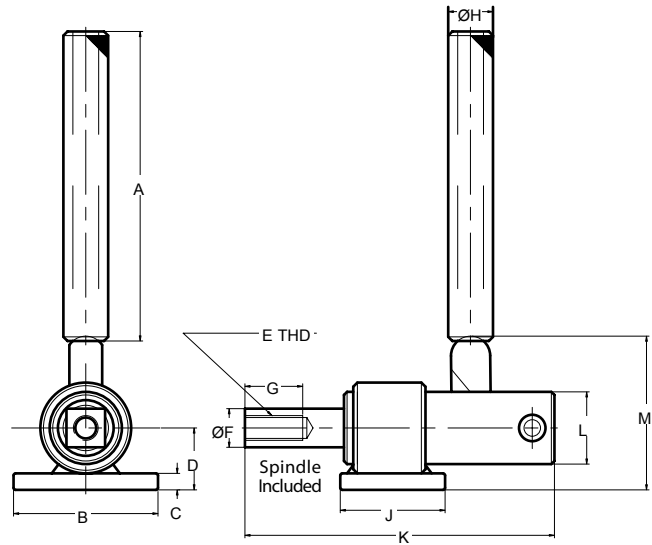

Model	Holding Capacity	Spindle Supplied	Plunger Stroke	A	B	C	D	E	ØF	G	ØH	J	K	L	M	Weight
GH-30509	2,500 lbs (1,136 kg)	GH-SA-12300	1.81 (46)	6" (152.4)	2.76 (70)	0.31 (8)	1.19 (30)	7/16-14 (M12 x 1.75)	0.75 (19)	1" (25.4)	0.85 (21.7)	2" (50.8)	5.91 (150)	1.37 (34.9)	2.91 (74)	2.93 lbs. (1,330 g)
GH-30609	5,000 lbs (2,273 kg)	GH-SA-58500	2.34 (60)	6" (152.4)	3.56 (90.5)	0.44 (11.2)	1.58 (40)	5/8-11 (M16 x 2)	1" (25.4)	1.5 (38.1)	1.07 (27.2)	2.69 (68.3)	7.80 (198)	1.75 (44.4)	3.43 (87)	6.22 lbs. (2,820 g)

UNIT: inch (metric mm)

30519 & 30619

Plunger locks at both ends of travel.



GH-30519

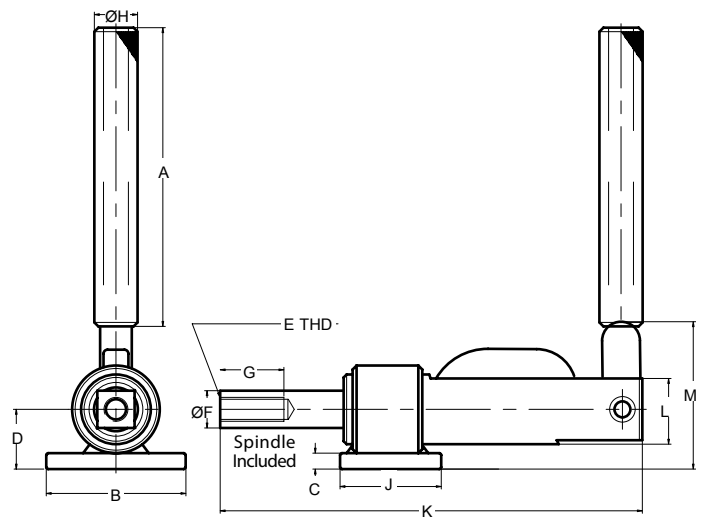

Model	Holding Capacity	Spindle Supplied	Plunger Stroke	A	B	C	D	E	ØF	G	ØH	J	K	L	M	Weight
GH-30519	2,500 lbs (1,136 kg)	GH-SA-12300	2.34 (60)	6" (152.4)	2.76 (70)	0.31 (8)	1.19 (30)	7/16-14 (M12 x 1.75)	0.75 (19)	1" (25.4)	0.85 (21.7)	2" (50.8)	8.34 (212)	1.37 (34.9)	2.91 (74)	3.62 lbs. (1,640 g)
GH-30619	5,000 lbs (2,273 kg)	GH-SA-58500	3.06 (78)	6" (152.4)	3.56 (91)	0.44 (11.2)	1.58 (40)	5/8-11 (M16 x 2)	1" (25.4)	1.5 (38.1)	1.07 (27.2)	2.69 (68.3)	11.14 (283)	1.75 (44.4)	3.43 (87)	7.72 lbs. (3,500 g)

UNIT: inch (metric mm)

Series 431

- Supplied with latch plate and standard U-bolt
- Optional Long U-Bolts available

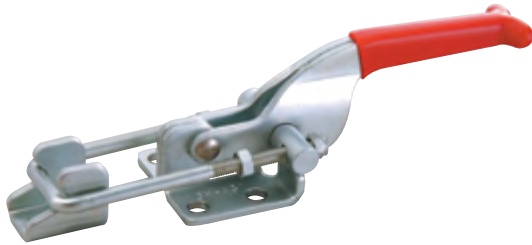

GH-431

Model	Description
GH-40323-SS	Stainless Steel Model of GH-40323
GH-431-SS	Stainless Steel Model of GH-431
GH-40341-SS	Stainless Steel Model of GH-40341

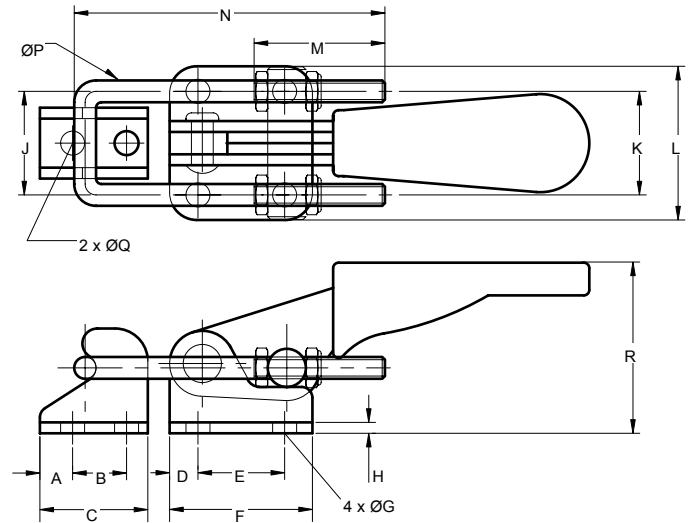

Model	Cross Ref. DE-STA-CO	Holding Capacity	A	B	C	D	E	F	G	H	J	K	L	M	N	P	Q	R	Weight
GH-40323	323	360 lbs. (163 kg)	0.24 (6)	0.39 (9.9)	0.78 (19.8)	0.20 (5.2)	0.63 (15.9)	1.03 (26.2)	0.17 (4.4)	0.08 (2)	0.75 (19)	0.75 (19)	1.11 (28.2)	0.94 (24)	2.24 (57)	0.16 (4)	0.17 (4.4)	1.15 (29.3)	0.16 lb. (70 g)
GH-431	331	700 lbs. (318 kg)	0.27 (6.8)	0.45 (11.5)	1" (25.4)	0.25 (6.4)	0.75 (19)	1.56 (39.7)	0.26 (6.7)	0.13 (3.2)	1.25 (31.8)	1.05 (26.6)	1.75 (44.4)	1.50 (38)	2.87 (73)	0.20 (5)	0.25 (6.3)	1.63 (41.3)	0.50 lb. (225 g)
GH-40341	341	2,000 lbs. (900 kg)	0.37 (9.5)	0.75 (19.1)	1.50 (38.1)	0.37 (9.5)	1.63 (41.3)	2.37 (60.3)	0.34 (8.6)	0.16 (4)	1.50 (38.1)	1.75 (44.5)	2.13 (54)	2.05 (52)	4.50 (114.5)	0.31 (8)	0.33 (8.5)	2.91 (74)	1.5 lbs. (680 g)

UNIQUE

Optional Long U-Bolts

When you need a longer reach, you need the LUB's; Long-Reach U-Bolts for use with latches.

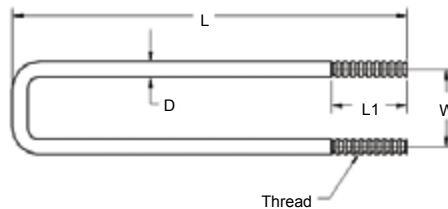

Model	Use with Model No.	Thread	L	L1	W	D
GH-40323-LUB	GH-40323	8-32	2.75	1.25	0.75	0.16
GH-40323-LUBSS			(70)	(31.8)	(19)	(4.1)
GH-431-LUB	GH-431	10-24	4.5	2	1.25	0.2
GH-431-LUBSS			(114)	(50.4)	(31.8)	(5.1)
GH-40341-LUB	GH-40341	5/16-18	6.25	3.13	1.50	0.3
GH-40341-LUBSS			(159)	(79.5)	(38.1)	(7.6)

UNIT: inch (metric mm)

Series 40840

- The unique latch offers dual mounting options: *horizontal and vertical*.
- Two pivot hole patterns are provided to accommodate two mounting positions.
- Supplied latch plate offers low profile clamping for side mounting applications.



GH-40870

GH-40840



GH-40820 mounted on a vertical position.

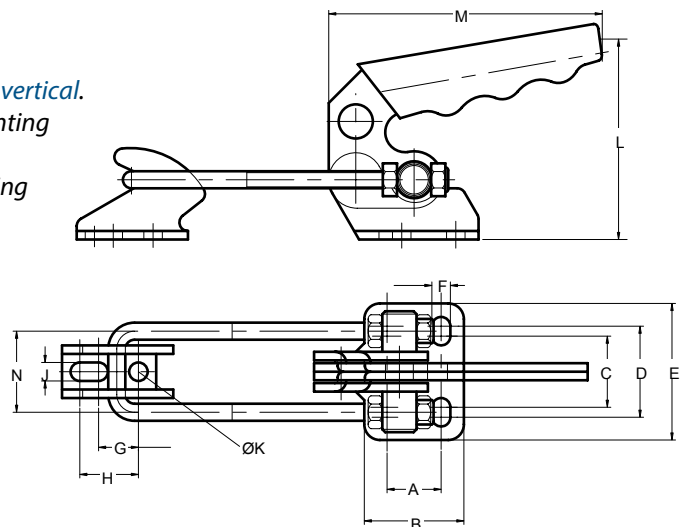

Model	Holding Capacity	A	B	C	D	E	F	G	H	J	ØK	L	M	N	Weight
GH-40820	440 lbs. (200 kg)	0.51 (13)	1.02 (26)	0.75 (19)	.95 (24)	1.42 (36)	0.20 (5.2)	0.43 (11)	-	0.20 (5.2)	0.20 (5.2)	1.81 (46)	2.56 (65)	0.83 (21)	0.24 lb. (110 g)
GH-40840	550 lbs. (250 kg)	0.75 (19)	1.38 (35)	0.98 (25)	1.26 (32)	1.89 (48)	0.26 (6.5)	0.55 (14)	0.81 (20.6)	0.26 (6.5)	0.26 (6.5)	2.87 (73)	3.82 (97)	1.12 (28.5)	0.67 lb. (306 g)
GH-40870	1,540 lbs. (700 kg)	1.26 (32)	2" (50.5)	1.42 (36)	1.77 (45)	2.50 (63.5)	0.33 (8.5)	0.75 (19)	1.06 (27)	0.33 (8.5)	0.33 (8.5)	3.46 (88)	4.61 (117)	1.75 (44.5)	1.54 lbs. (700 g)

UNIT: inch (metric mm)

Series 40324

· Supplied with latch plate

These unique latch clamps are designed for enclosure applications where the clamps are perpendicular to the latches.



GH-40324

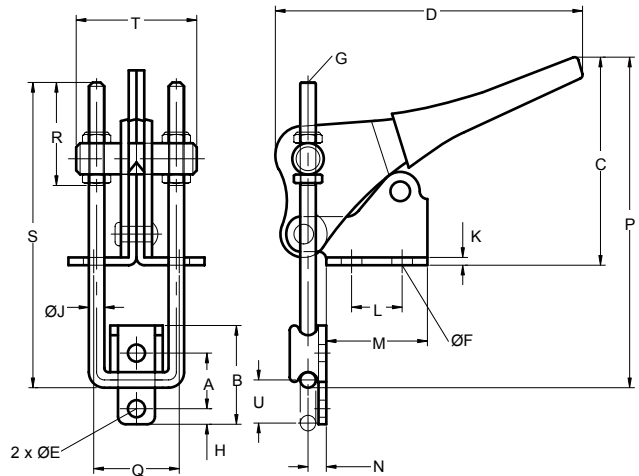

Model	Cross Ref. DE-STA-CO	Holding Capacity	A	B	C	D	ØE	ØF	G	H	ØJ	K	L	M	N	P	Q	R	S	T	U	Weight
GH-40324	324	500 lbs. (225 kg)	0.56 (14.3)	1" (25.4)	2.09 (53.3)	3.11 (79)	0.17 (4.4)	0.21 (5.3)	8-32	0.16 (4)	0.16 (4)	0.08 (2)	0.51 (13)	1.02 (26)	0.19 (4.7)	2.76 (70)	0.87 (22)	1.04 (26.5)	3.09 (78.5)	1.22 (31)	0.44 (11.1)	0.25 lb. (113 g)
GH-40334	334	1,000 lbs. (450 kg)	0.81 (20.6)	1.50 (38.1)	2.44 (61.9)	4.72 (120)	0.28 (7.1)	0.28 (7.1)	1/4-20	0.28 (7.1)	0.25 (6.4)	0.12 (3)	0.75 (19.1)	1.31 (33.3)	0.34 (8.7)	4.02 (102)	1" (25.4)	1.59 (40.5)	4.49 (114)	1.63 (41.3)	0.39 (17.5)	0.56 lb. (250 g)
GH-40344	344	2,000 lbs. (900 kg)	1.06 (27)	2.13 (54)	3.31 (84.1)	5.13 (130)	0.34 (8.7)	0.21 (5.3)	5/16-18	0.37 (9.5)	0.31 (7.9)	0.16 (4)	1.25 (31.8)	1.87 (47.6)	0.50 (12.7)	5.91 (150)	1.44 (36.5)	2.28 (58)	6.06 (154)	2.37 (60.3)	1.13 (28.6)	1.54 lbs. (700 g)

UNIT: inch (metric mm)

Series 451

These are the most popular latch clamps with adjustable single hook design. Model GH-451 has a flanged base, while Model GH-452 has a narrow base which is less tolerant to twisting motions. Stainless steel models are available. Optional Latch Plates are also available.



GH-452

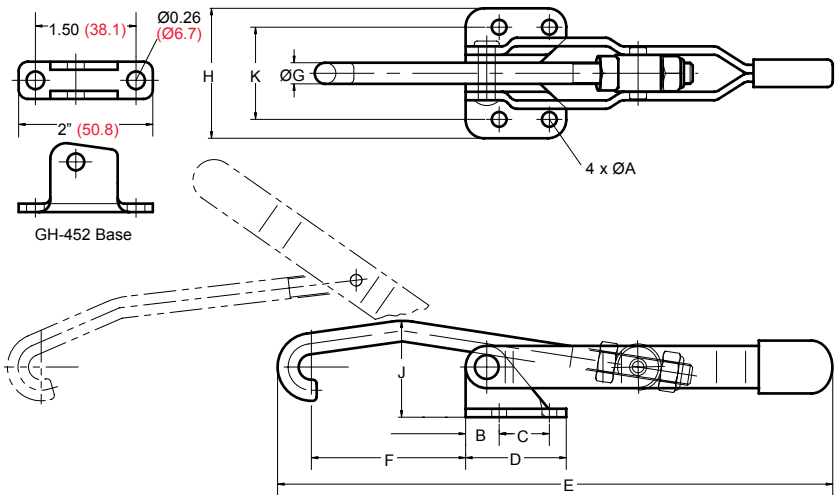

UNIT: inch (metric mm)

Model	Cross Ref.: DE-STA-CO	Description	Holding Capacity	A	B	C	D	E	F	ØG	H	J	K	Weight	Optional Latch Plate
GH-451	351	Flanged Base	375 lbs. (170 kg)	0.22 (5.6)	0.50 (12.7)	0.75 (19)	1.50 (38.1)	8.31 (211)	2.30 (58.4)	0.31 (8)	1.94 (49.2)	1.44 (36.5)	1.37 (34.9)	0.59 lb. (270 g)	GH-451-LP
GH-451-SS	351-SS	Stainless Steel Model of GH-451													GH-451-LPSS
GH-452	351-B	Narrow Base	375 lbs. (170 kg)	0.26 (6.7)	-	1.50 (38.1)	2" (50.8)	8.31 (211)	1.76 (44.8)	0.31 (8)	-	1.44 (36.5)	-	0.56 lb. (255 g)	GH-452-LP
GH-452-SS	351-BSS	Stainless Steel Model of GH-452													GH-452-LPSS
GH-40371	371	Flanged Base	750 lbs. (340 kg)	0.34 (8.7)	0.31 (7.9)	1.25 (31.8)	1.87 (47.6)	11.22 (285)	3.13 (79.4)	0.37 (9.5)	2.59 (65.7)	2.25 (57.3)	1.94 (49.2)	1.38 lbs. (624 g)	GH-40371-LP
GH-43810	381	Flanged Base	1,000 lbs. (450 kg)	0.41 (10.3)	0.50 (12.7)	1.13 (28.6)	2.13 (54)	13.23 (336)	3" (76.2)	0.50 (12.7)	3.37 (85.7)	2.68 (68)	2.37 (60.3)	2.56 lbs. (1,130 g)	GH-43810-LP

UNIT: inch (metric mm)

43101

- Cross Ref.: DE-STA-CO Model 301
- Holding Capacity: 375 lbs. (170 kg)
- Weight: 0.68 lb. (310 g)
- Optional latch plate model *GH-43101-LP*



GH-43101

Model	A	B	C	D	E	F
GH-43101	0.57 (14.4)	0.40 (10)	0.13 (3.2)	0.75 (19)	1.37 (34.8)	0.50 (12.7)

UNIT: inch (metric mm)

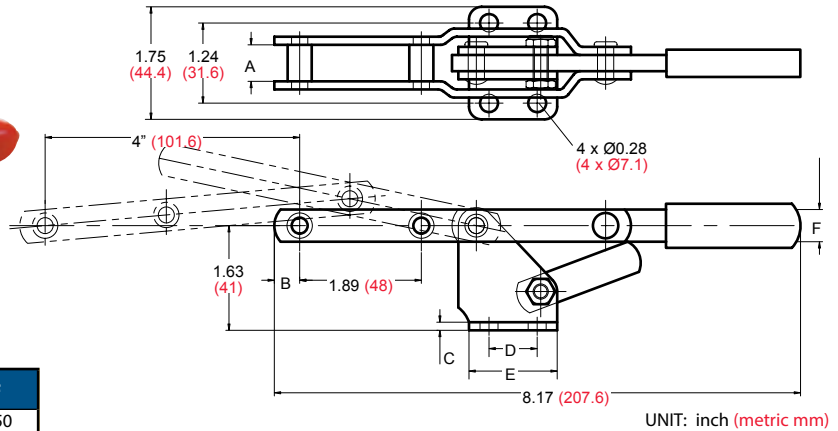

UNIT: inch (metric mm)

43110 & 43120

- Holding Capacity: 375 lbs. (170 kg)
- Weight: 0.40 lb. (180 g)
- GH-43110 supplied with 1/4-20 hook bolt
- GH-43120 supplied with hex head spindle assembly.

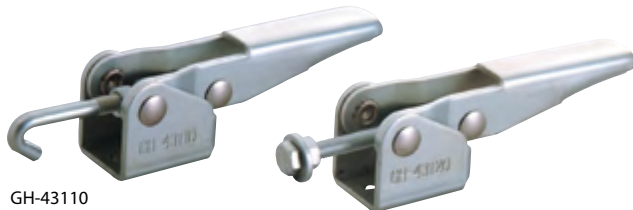

GH-43110

Optional latch plate
model *GH-43110-LP*

GH-43120

Optional latch plate
model *GH-43120-LP*

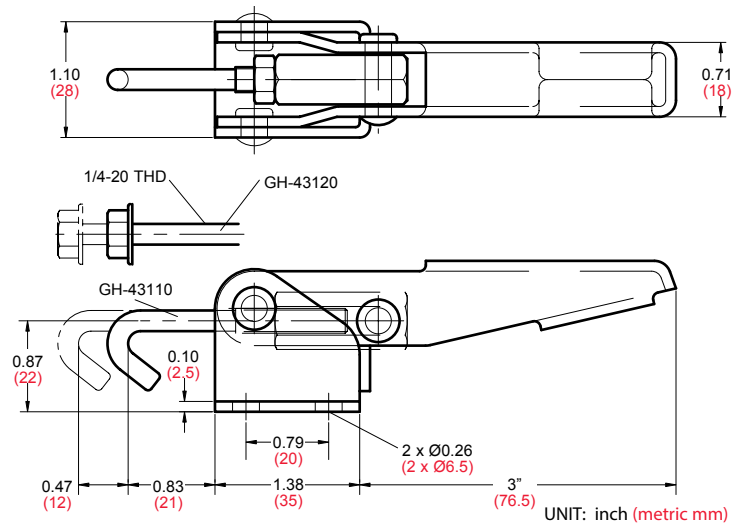

UNIT: inch (metric mm)

43150 & 43160

- Holding Capacity: 660 lbs. (300 kg)
- Weight: 0.85 lb. (385 g)
- GH-43150 supplied with 3/8-16 hook bolt
- GH-43160 supplied with hex head spindle assembly.



GH-43150

Optional latch plate
model *GH-43150-LP*

GH-43160

Optional latch plate
model *GH-43160-LP*

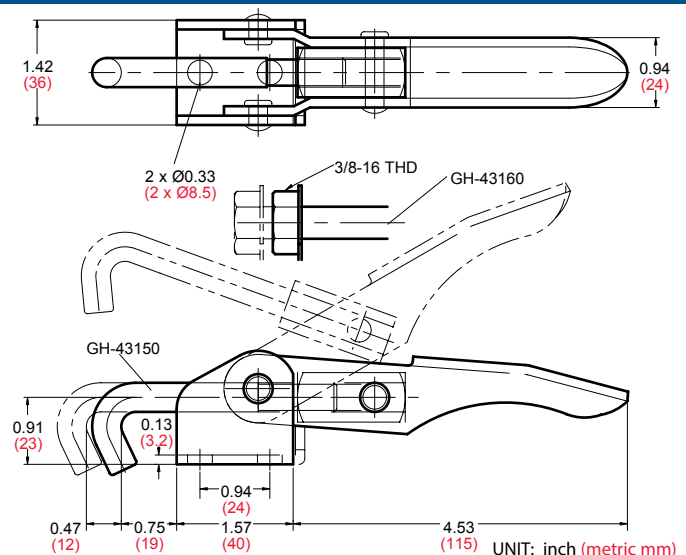

UNIT: inch (metric mm)

40370

- Cross Ref.: DE-STA-CO Model 375
- Holding Capacity: 4,000 lbs. (1,818 kg)
- Weight: 2.78 lbs. (1,260 g)

Both the alloy steel base and the optional latch plate are forged for strength and durability.



GH-40370-LP GH-40370

Model	A	B	C
GH-40370	0.75 (19)	1.37 (34.9)	2.25 (57)

UNIT: inch (metric mm)

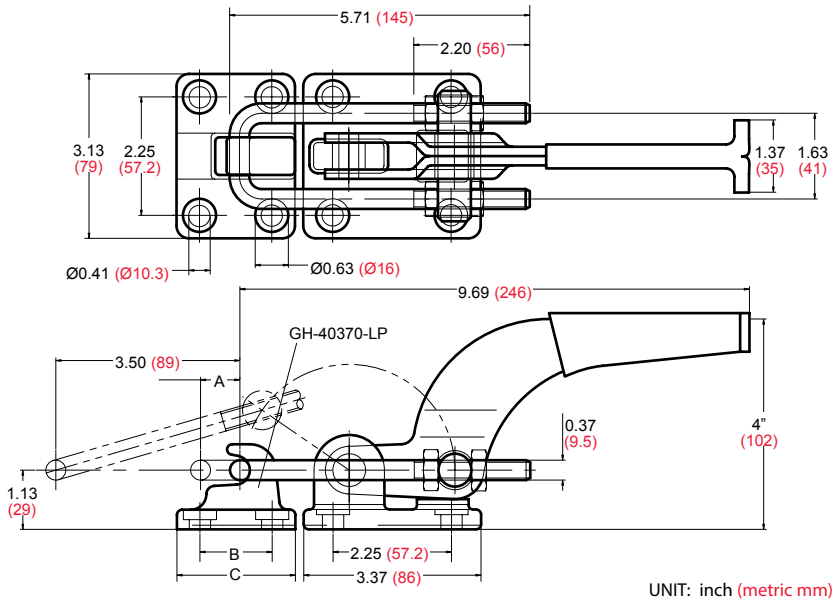

UNIT: inch (metric mm)

40380

- Cross Ref.: DE-STA-CO Model 385
- Holding Capacity: 7,500 lbs. (3,400 kg)
- Weight: 3.25 lbs. (1,480 g)

This extra heavy model and optional latch plate has all forged part construction.



GH-40380-LP GH-40380

Model	ØA	ØB	C	D
GH-40380	0.43 (10.3)	0.63 (16)	1.13 (28.6)	1.37 (34.9)

UNIT: inch (metric mm)

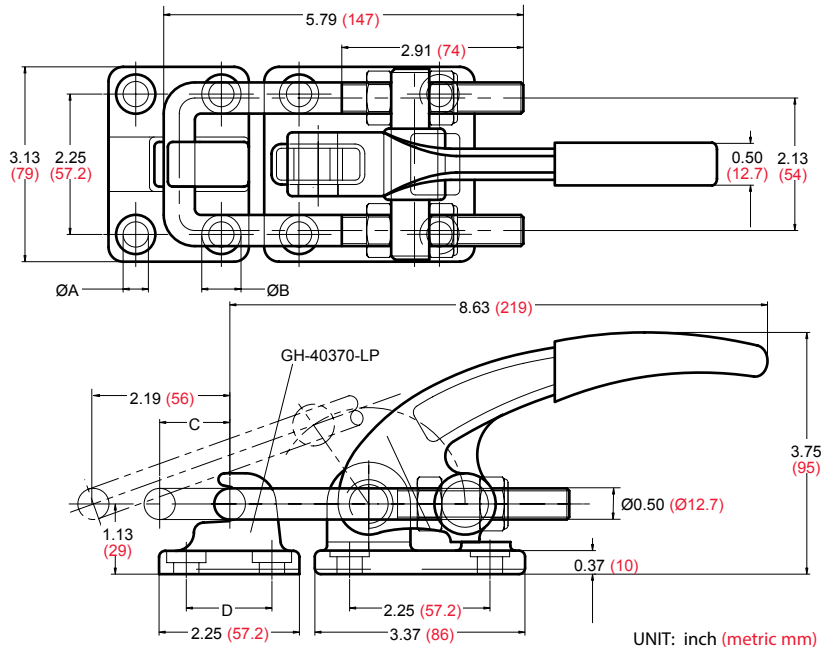

UNIT: inch (metric mm)

All Pliers are forged from alloy steel with stainless steel rivots for durability.

50350

- Cross Ref.: DE-STA-CO Model 424
- Holding Capacity: 200 lbs. (90 kg)
- Weight: 0.41 lb. (185 g)
- Spindle Supplied: GH-SA-14112

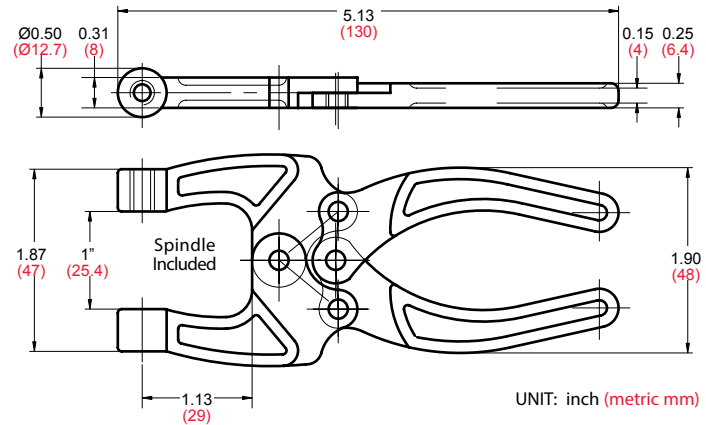

50360

- Cross Ref.: DE-STA-CO Model 441
- Holding Capacity: 350 lbs. (159 kg)
- Weight: 0.64 lb. (290 g)
- Spindle Supplied: GH-SA-56200

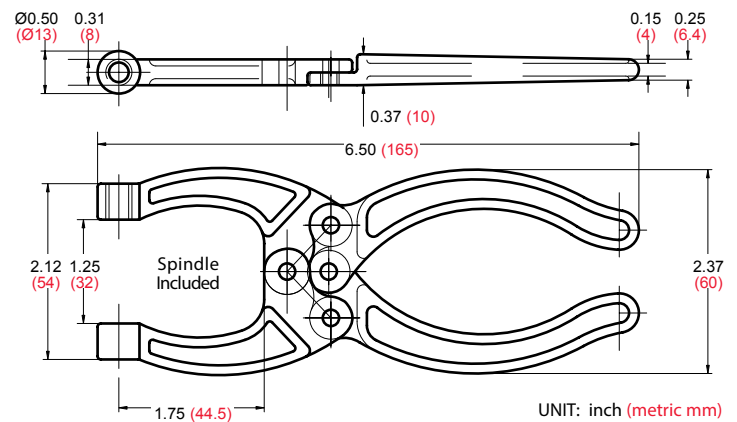

50380

- Cross Ref.: DE-STA-CO Model 462
- Holding Capacity: 700 lbs. (318 kg)
- Weight: 1.46 lbs. (660 g)
- Spindle Supplied: GH-SF-38300

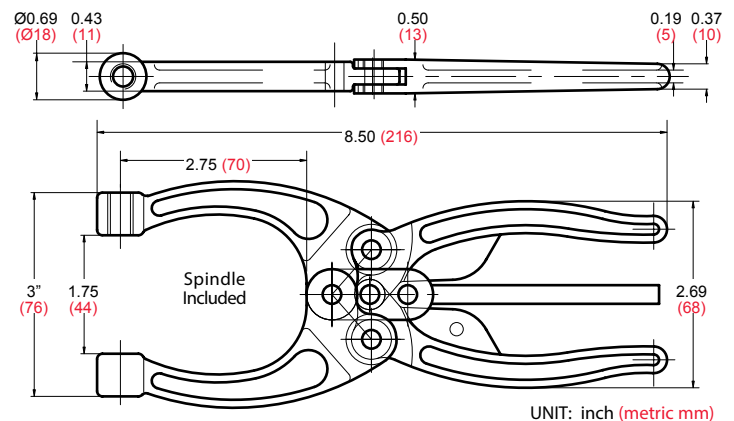

50385

- Holding Capacity: 1,800 lbs. (820 kg)
- Weight: 1.56 lbs. (710 g)
- Spindle Supplied: GH-SF-38114

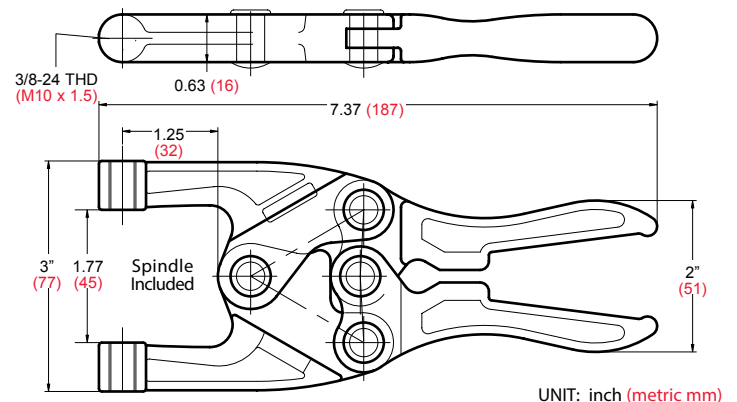

61352

- Holding Capacity: 200 lbs. (90 kg)
- Weight: 0.3 lb. (130 g)

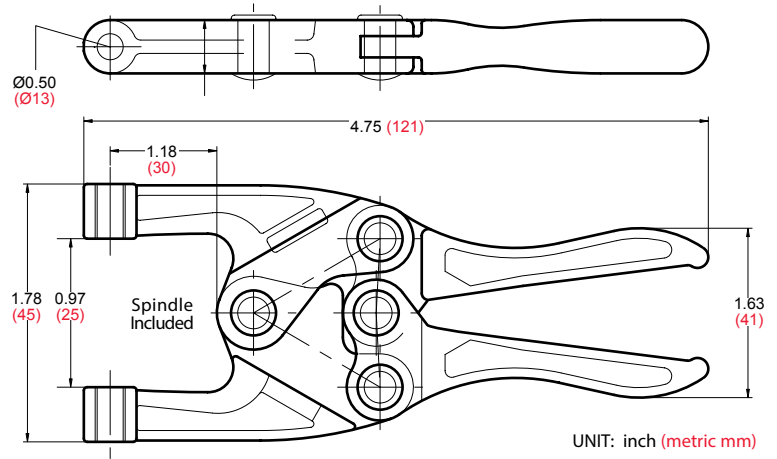

50450

- Cross Ref.: DE-STA-CO Model 463
- Holding Capacity: 700 lbs. (318 kg)
- Weight: 1.63 lbs. (740 g)
- Spindle Supplied: GH-SF-38300 swivel foot and GH-SA-38300 hex head spindle assembly

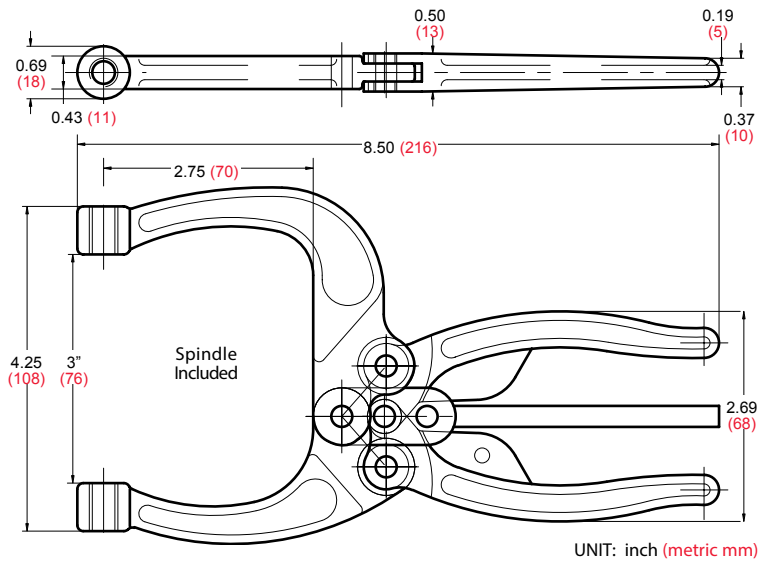

50480

- Cross Ref.: DE-STA-CO Model 480
- Holding Capacity: 1,100 lbs. (500 kg)
- Weight: 1.32 lbs. (600 g)

Two stub jaws for easy linking to special jaw extensions

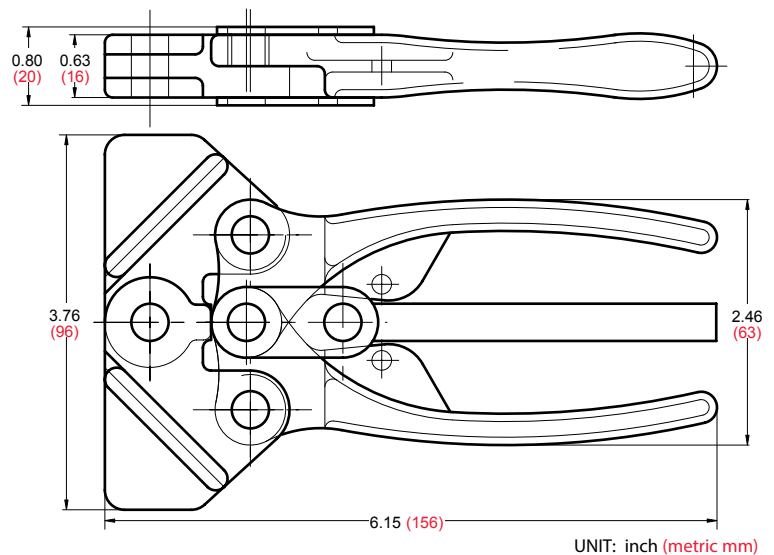

60130 & 60131

- Designed to hold work-piece with inconsistent height.
- Cam Action permits hold down material deviation of 0.125" (3.2 mm) in height.
- Ideal for castings and forgings, etc.

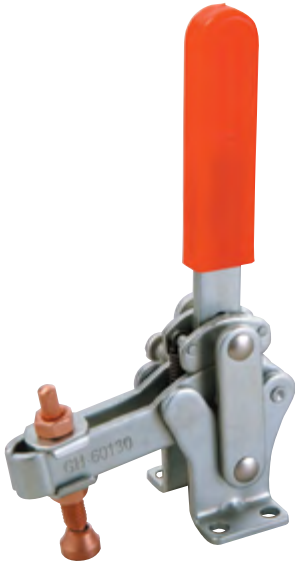

GH-60130

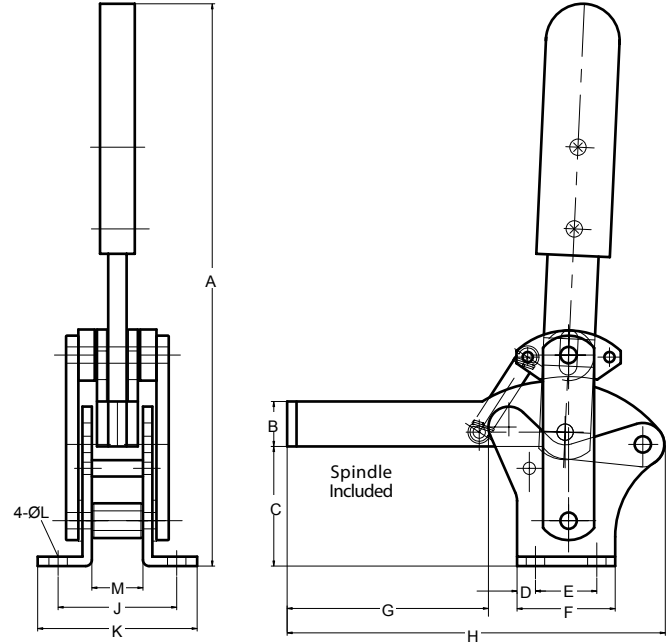

Model	Holding Capacity	Spindle Supplied	Bar Opens	Handle Opens	A	B	C	D	E	F	G	H	J	K	ØL	M	Weight
GH-60130	550 lbs. (250 kg)	GH-SF-38300	70°	165°	8.66 (220)	0.75 (19)	1.54 (39)	0.25 (6.5)	0.87 (22)	1.38 (35)	2.28 (58)	4.65 (118)	1.89 (48)	2.44 (62)	0.31 (8)	0.79 (20)	1.50 lb. (680g)
GH-60131	770 lbs. (350kg)	GH-SF-12400	85°	170°	10.83 (275)	0.87 (22)	2.36 (60)	0.35 (9)	1.18 (30)	1.89 (48)	3.94 (100)	7" (178)	2.24 (57)	3.03 (77)	0.35 (9)	0.98 (25)	3.51 lbs. (1,590g)

UNIT: inch (metric mm)

35 These heavy-duty clamps provide the strong, durable holding power to meet the requirements of the auto industry. These clamps are forged from alloy steel, hardened, and ground to close tolerance. Pins are also hardened and grounded. A separate handle is included with each clamp for welding in the desired position.

Series 701 & 702

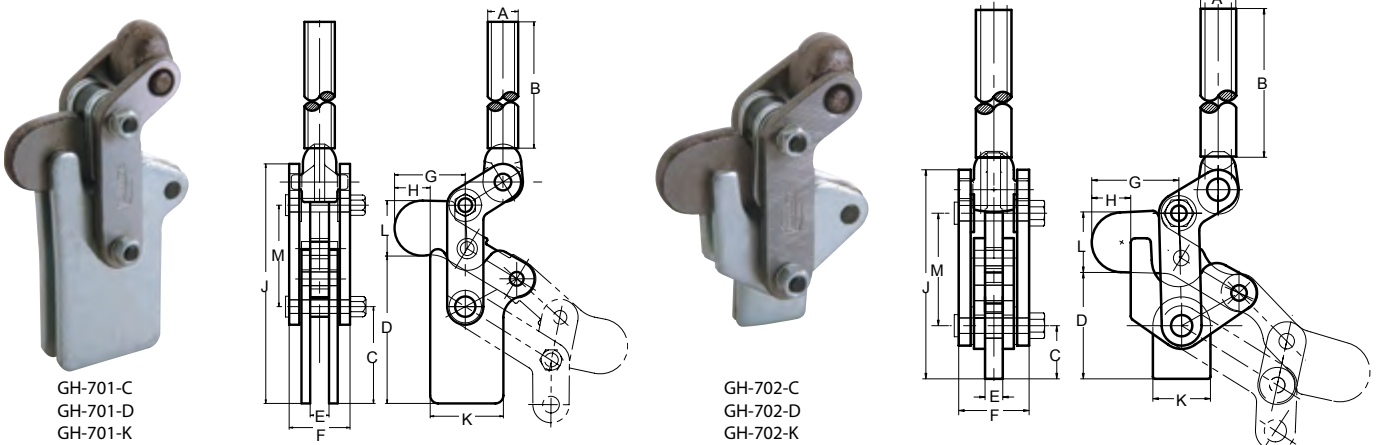

Model	Holding Capacity	Arm Opens	Handle Opens	ØA	B	C	D	E	F	G	H	J	K	ØL	M	Weight
GH-701-C	440 lbs. (200 kg)	194°	123°	0.68 (17.3)	6" (152.4)	1.96 (50)	0.57 (14.5)	0.31 (8)	1.25 (31.8)	1.57 (40)	0.67 (17)	4.75 (121)	1.75 (44.5)	1.10 (28)	2" (50.8)	1.32 lbs. (598g)
GH-701-D	1,100 lbs. (500 kg)	191°	122°	0.85 (21.7)		2.69 (66.8)	4" (102)	0.51 (13)	1.65 (42)	1.92 (48.8)	0.97 (24.6)	6.50 (165)	1.97 (50)	1.54 (39)	2.75 (70)	3.50 lbs. (1,587 g)
GH-701-K	2,200 lbs. (1,000 kg)	197°	128°	1.07 (27.2)		3.15 (80)	4.84 (123)	0.63 (16)	1.81 (46)	2.09 (53)	0.98 (25)	8.07 (205)	2.48 (63)	2.05 (52)	3.54 (90)	5.84 lbs. (2,650 g)
GH-702-C	440 lbs. (200 kg)	194°	123°	0.68 (17.3)		0.94 (23.8)	1.89 (48)	0.31 (8)	1.25 (31.8)	1.57 (40)	0.67 (17)	3.66 (93)	1.02 (26)	1.10 (28)	2" (50.8)	1.50 lbs. (680 g)
GH-702-D	1,100 lbs. (500 kg)	191°	122°	0.85 (21.7)		1.33 (33.7)	2.72 (69)	0.51 (13)	1.65 (42)	1.92 (48.8)	0.97 (24.6)	5.20 (132)	1.43 (36.4)	1.54 (39)	2.75 (70)	3.24 lbs. (1,469 g)
GH-702-K	2,200 lbs. (1,000 kg)	197°	128°	1.07 (27.2)		1.46 (37.2)	3.30 (84)	0.63 (16)	1.81 (46)	2.09 (53)	0.98 (25)	6.57 (167)	2.13 (54)	2.05 (52)	3.54 (90)	5.75 lbs. (2,608 g)

Series 70305

Model	Cross Ref.: DE-STA-CO	Holding Capacity	Arm Opens	Handle Opens
GH-70305	503-M	1,100 lbs. (500 kg)	214°	134°
GH-70310	503-MB			
GH-70315	503-MLB			
GH-70505	505-M	2,200 lbs. (1,000 kg)	206°	130°
GH-70510	505-MB			
GH-70515	505-MLB			
GH-70605	506-M	4,400 lbs. (2,000 kg)	206°	130°
GH-70610	506-MB			
GH-70615	506-MLB			



Model	ØA	B	C	D	D1	E	F	G	H	K	K1	L	Weight
GH-70305	0.69 (17.5)	4.9 (125)	0.19 (4.8)	-	-	0.39 (10)	1.25 (31.8)	1.57 (40)	0.59 (15)	-	-	2" (51)	1.68 lbs. (760g)
GH-70310				0.79 (20)	-					1.14 (29)	-		1.87 lbs. (850 g)
GH-70315				1.97 (50)	1.97 (50)					-	1.77 (45)		2.07 lbs. (940 g)
GH-70505	0.87 (22.2)	4.9 (125)	0.19 (4.8)	-	-	0.48 (12.3)	1.59 (40.3)	2.24 (57)	1.02 (26)	-	-	2.87 (73)	2.93 lbs. (1,330 g)
GH-70510				1.10 (28)	-					1.50 (38)	-		3.28 lbs. (1,490 g)
GH-70515				2.50 (63.5)	2.50 (63.5)					-	2" (51)		3.51 lbs. (1,590 g)
GH-70605	1.06 (27)	4.9 (125)	0.25 (6.3)	-	-	0.63 (16)	1.91 (48.6)	2.93 (74.3)	1.30 (33)	-	-	3.58 (91)	5.62 lbs. (2,550 g)
GH-70610				1.30 (33)	-					2" (51)	-		6.24 lbs. (2,830 g)
GH-70615				3" (76)	3" (76)					-	2.50 (63.5)		6.50 lbs. (2,950 g)

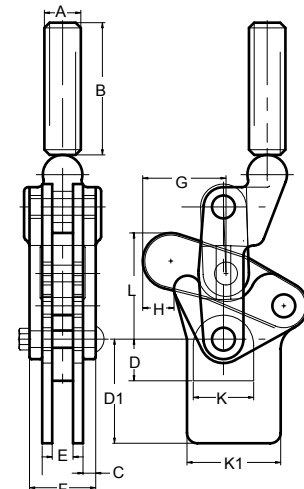

75027 & 75027-SM

- Cross Ref.: DE-STA-CO Model 527 & 527-F
- Holding Capacity: 1,000 lbs. (450 kg)
- Weight: 2.51 lbs. (1,140 g)
- Bar Opens: 195°
- Handle Moves: 65°



GH-75027

Model	A	B	C	ØD	ØE
GH-75027	0.75 (19)	0.75 (19)	1.50 (38)	0.41 (10.3)	0.69 (17.5)

UNIT: inch (metric mm)

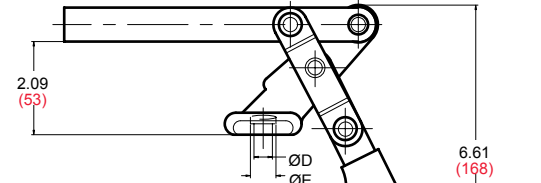
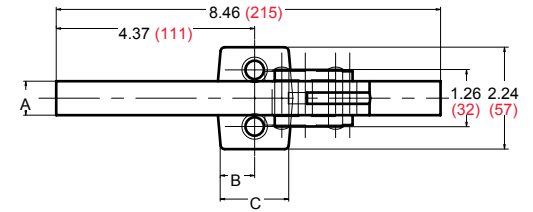

UNIT: inch (metric mm)



GH-75027-SM

Model	A	B	ØC	ØD
GH-75027-SM	0.75 (19)	0.75 (19)	0.41 (10.3)	0.69 (17.5)

UNIT: inch (metric mm)

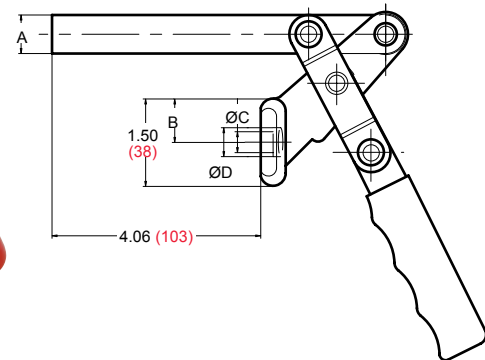
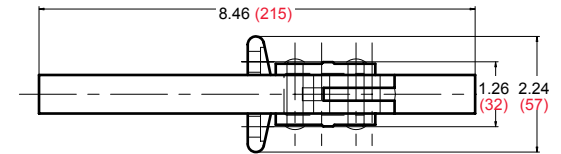

UNIT: inch (metric mm)

75048 & 75078

- Cross Ref.: DE-STA-CO Model 548 & 578



GH-75048

Model	Holding Capacity	Arm Opens	Handle Opens	A	B	C	D	E	F	G	Weight
GH-75048	1,500 lbs. (700 kg)	200°	110°	3.25 (82.6)	2.65 (67.2)	4.26 (108)	1" (25.4)	9.92 (252)	2.20 (56)	0.75 (19)	5.95 lbs. (2,700 g)
GH-75078	3,500 lbs. (1,600 kg)	200°	110°	4" (101.6)	2.72 (69.2)	4.63 (117.5)	1.26 (32)	10.87 (276)	2.57 (65.2)	0.87 (22.2)	9.26 lbs. (4,200 g)

UNIT: inch (metric mm)

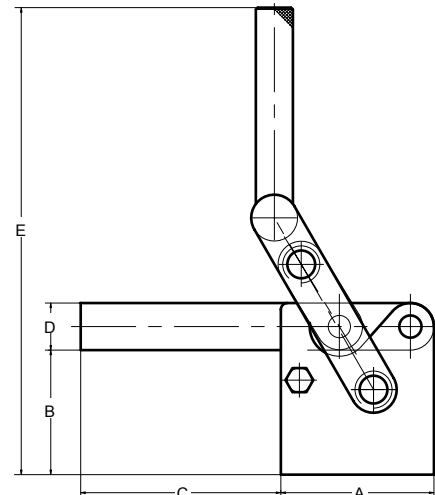
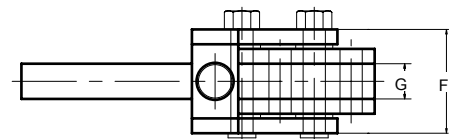

80070

- Holding Capacity: 440 lbs. (200 kg)
- Weight: 0.22 lbs. (100 g)
- Screw stroke: 3.35" (85 mm)



GH-80070

Model	A	B	C	D	E	F	G
GH-80070	0.67 (17)	0.31 (8)	0.63 (16)	0.51 (13)	0.59 (15)	0.51 (13)	0.63 (16)

UNIT: inch (metric mm)

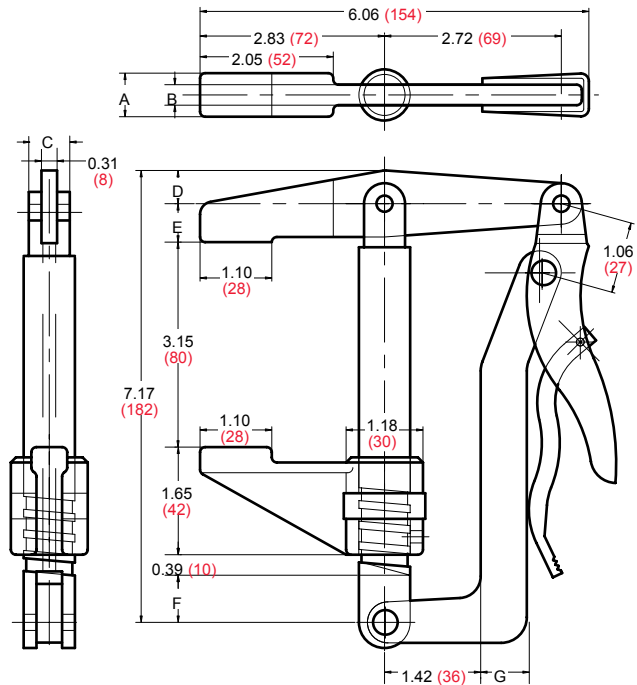

UNIT: inch (metric mm)

80325 & 80325-SS

- Cross Ref.: DE-STA-CO Model 325 & 325-SS
- Holding Capacity: 750 lbs. (340 kg)
- Weight: 1.10 lbs. (500 g)
- Handle Opens: 50°
- Jaw Opens: 90°
- Spindle Supplied
- **Stainless Steel** Model GH-80325-SS available

The bottom jaw is designed to be welded to container or cover. The forged jaw swings 90° for easy job loading. 1/2-13 Hex spindle supplied.



GH-80325

Model	A	B
All	0.59 (31.8)	0.29 (7.5)

UNIT: inch (metric mm)

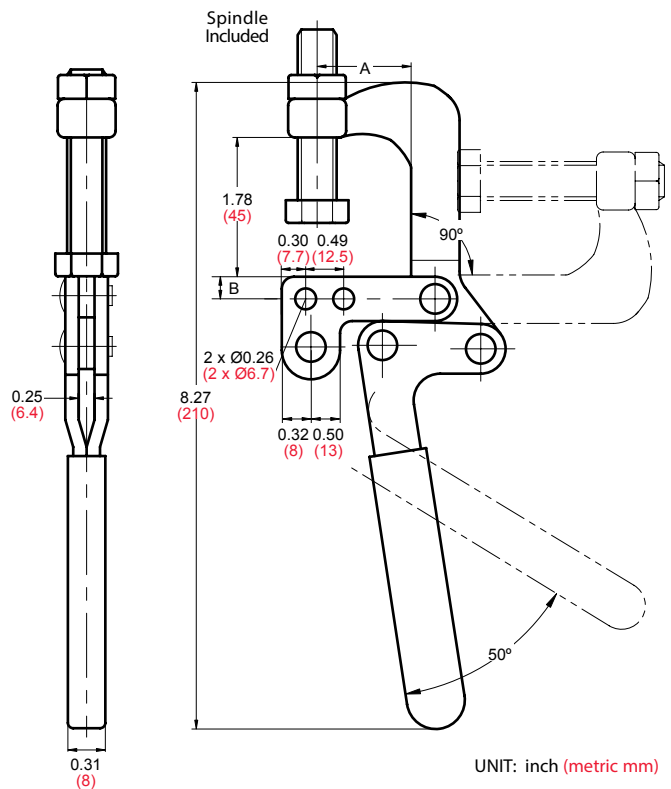

UNIT: inch (metric mm)

All these fast acting air clamps use standard toggle clamps as the basic platform. All have 1/8 NPT port standard. Maximum air pressure allowed in the cylinder is 140 PSI.



GH-10101-A



GH-12050-A

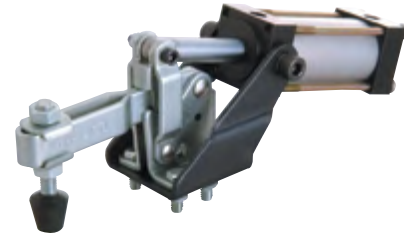

GH-12130-A & GH-12132-A

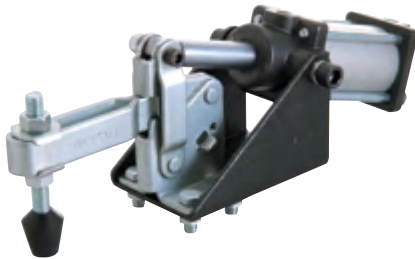

GH-12265-A & GH-12275-A



GH-10247-A & GH-10249-A



GH-20820-A

Specifications

Model	Basic Model	Holding Capacity	Spindle Supplied	Bar Opens	Cylinder Bore	Cylinder Stroke
GH-10101-A	GH-101-A	150 lbs (68 kg)	GH-FC-10138	82°	0.78 (20)	1.24 in. ² (31.4 mm ²)
GH-12050-A	GH-12050	200 lbs (90 kg)	GH-FC-14134	95°	1.18 (30)	2.78 in. ² (70.7 mm ²)
GH-12130-A	GH-12130	350 lbs (160 kg)	GH-FC-56212	92°	1.18 (30)	2.78 in. ² (70.7 mm ²)
GH-12132-A	GH-12132	350 lbs (160 kg)	GH-FC-56212	92°	1.18 (30)	2.78 in. ² (70.7 mm ²)
GH-12265-A	GH-12265	600 lbs (272 kg)	GH-FC-38312	95°	1.57 (40)	4.94 in. ² (125.6 mm ²)
GH-12275-A	GH-12275	600 lbs (272 kg)	GH-FC-38312	95°	1.57 (40)	4.94 in. ² (125.6 mm ²)
GH-10247-A	GH-10247	800 lbs (364 kg)	GH-FC-12300	95°	2 (50)	7.73 in. ² (196.3 mm ²)
GH-10249-A	GH-10249	800 lbs (364 kg)	GH-FC-12300	95°	2 (50)	7.73 in. ² (196.3 mm ²)
GH-20820-A	GH-20820	350 lbs (160 kg)	GH-FC-56212	90°	1.18 (30)	2.78 in. ² (31.4 mm ²)

UNIT: inch (metric mm)

Dimensions

Model	A	B	C	ØD	E	F	G	H
GH-10101-A	0.94 (23.8)	0.20 (4.8)	0.63 (15.9)	0.13 (4.4)	1.60 (40.7)	0.69 (17.5)	0.94 (24)	6.63 (168.5)
GH-12050-A	1.06 (27)	0.25 (6.3)	0.50 (12.7)	0.20 (5.2)	2.19 (55.7)	1.06 (27)	1.38 (35)	7.28 (185)
GH-12130-A	1.26 (32)	0.39 (10)	0.75 (19)	0.28 (7.1)	2.97 (75.4)	1.33 (33.8)	2.68 (68)	9.31 (236.5)
GH-12132-A	1.26 (32)	0.39 (10)	0.75 (19)	0.28 (7.1)	2.97 (75.4)	1.35 (34.2)	3.47 (88.2)	10.24 (260)
GH-12265-A	1.78 (45.2)	0.37 (9.5)	1.25 (31.8)	0.33 (8.3)	3.69 (93.7)	1.75 (44.2)	3.47 (88.2)	15.43 (392)
GH-12275-A	1.78 (45.2)	0.37 (9.5)	1.25 (31.8)	0.33 (8.3)	3.69 (93.7)	1.75 (44.2)	3.47 (88.2)	11.89 (302)
GH-10247-A	1.78 (45.2)	0.74 (19)	1.25 (31.8)	0.33 (8.3)	4.33 (110)	2.18 (55.3)	4.52 (114.8)	16.02 (407)
GH-10249-A	1.78 (45.2)	0.74 (19)	1.25 (31.8)	0.33 (8.3)	4.33 (110)	2.18 (55.3)	4.52 (114.8)	16.02 (407)
GH-20820-A	0.98 (25)	0.65 (17)	0.63 (16)	0.28 (7)	7.68 (195)	2.75 (70)	2.36 (60)	6.50 (165)

UNIT: inch (metric mm)

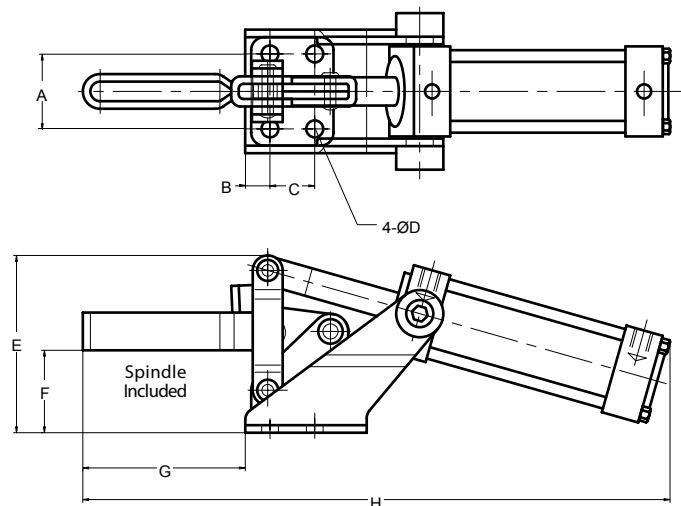



GH-36301-A

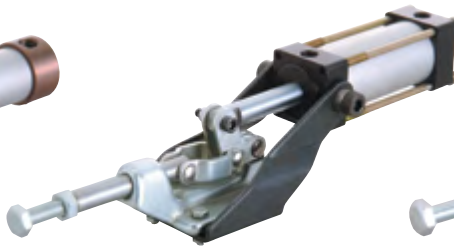

GH-36003-A



GH-36330-A

Specifications

Model	Basic Model	Holding Capacity	Spindle Supplied	Cylinder Bore	Cylinder Stroke
GH-36301-A	GH-301-A	100 lbs (454 kg)	GH-SA-08034	0.75 (20)	1.24 in. ² (3.14 cm ²)
GH-36003-A	GH-36003	600 lbs (273 kg)	GH-SA-56200	1.18 (30)	2.78 in. ² (7.07 cm ²)
GH-36330-A	GH-36330	2,500 lbs (1,136 kg)	GH-SA-38300	1.57 (40)	4.94 in. ² (12.56 cm ²)

UNIT: inch (metric mm)

Dimensions

Model	A	B	ØC	D	E	F	G	H	J	K
GH-36301-A	0.63 (15.9)	0.25 (6.4)	0.17 (4.4)	1.27 (32.2)	1.57 (40)	0.63 (15.9)	-	0.47 (12)	0.54 (13.6)	7.36 (187)
GH-36003-A	1.31 (33.3)	0.44 (11.1)	0.22 (5.6)	2.28 (58)	2.74 (69.5)	1.44 (36.5)	-	0.78 (19.7)	1.09 (27.7)	9.84 (250)
GH-36330-A	1.63 (41.3)	0.63 (15.9)	0.34 (8.7)	2.03 (51.5)	3.30 (84)	1.37 (34.9)	1.63 (41.3)	1.18 (30)	1.05 (26.6)	13.66 (347)

UNIT: inch (metric mm)

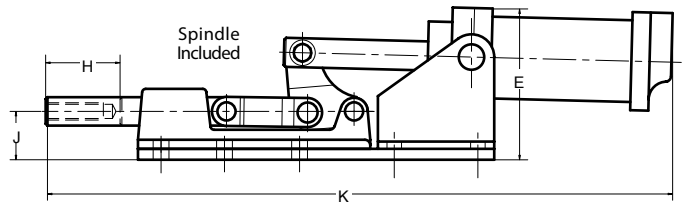
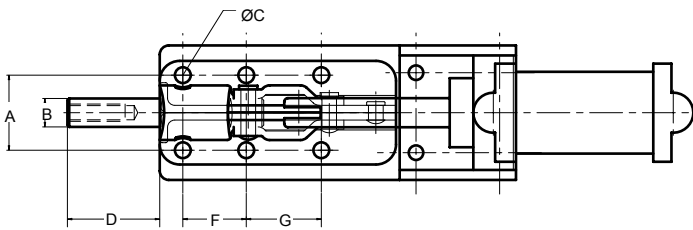

Yoke Assemblies

Hold two workpieces, or long pieces of fabric or metal. The yokes have spring loaded, extra-wide spindles that provide strong, no-mar holding power that can be adjusted to accommodate varying material thicknesses and sizes.



GH-YP-3145 Yoke attached to GH-304-E Clamp (Sold separately)

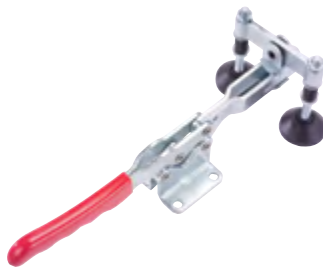

GH-YP-3130 Yoke attached to GH-20235 Clamp (Sold separately)



GH-YP-3160 Yoke attached to GH-12265 Clamp (Sold separately)

Plastic Pad Part No.	Neoprene Cap Part No.	Plain Spindle Part No.	A	L
GH-YP-3130	GH-YN-3130	GH-YB-3130	5/16-18	3" (76.2)
GH-YP-3145	GH-YN-3145	GH-YB-3145	5/16-18	4.5" (114.3)
GH-YP-3160	GH-YN-3160	GH-YB-3160	5/16-18	6" (152.4)
GH-YP-3730	GH-YN-3730	GH-YB-3730	3/8-16	3" (76.2)
GH-YP-3745	GH-YN-3745	GH-YB-3745	3/8-16	4.5" (114.3)
GH-YP-3760	GH-YN-3760	GH-YB-3760	3/8-16	6" (152.4)

UNIT: inch (metric mm)

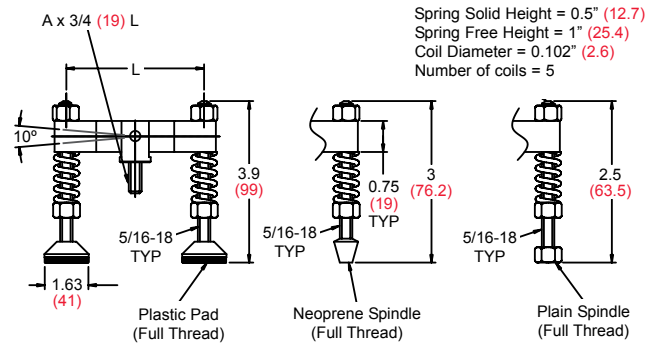

UNIT: inch (metric mm)

Adjustable Spindle Assemblies

Flat Cushion Tip Bonded Neoprene Cap

Zinc-plated finish

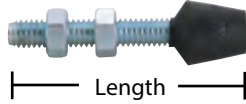

Part No.	Description
GH-FC-10138	10-24 x 1-3/8
GH-FC-14134	1/4-20 x 1-3/4
GH-FC-14218	1/4-20 x 2-1/8
GH-FC-56212	5/16-18 x 2-1/2
GH-FC-56300	5/16-18 x 3
GH-FC-38312	3/8-16 x 3-1/2
GH-FC-38412	3/8-16 x 4-1/2
GH-FC-12334	1/2-13 x 3-3/4

Standard Adjustable

Zinc-plated finish

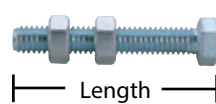

Part No.	Description
GH-SA-08034	8-32 x 3/4 (nylon)
GH-SA-10118	10-24 x 1-1/8
GH-SA-14112	1/4-20 x 1-1/2
GH-SA-14134	1/4-20 x 1-3/4
GH-SA-56200	5/16-18 x 2
GH-SA-56212	5/16-18 x 2-1/2
GH-SA-38300	3/8-16 x 3
GH-SA-38400	3/8-16 x 4
GH-SA-12300	1/2-13 x 3
GH-SA-12412	1/2-13 x 4-1/2
GH-SA-58500	5/8-11 x 5

Cone Cushion Tip Bonded Neoprene Cap

Zinc-plated finish

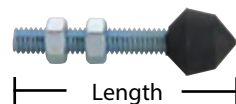

Part No.	Description
GH-CC-10138	10-24 x 1-3/8
GH-CC-14134	1/4-20 x 1-3/4
GH-CC-14218	1/4-20 x 2-1/8
GH-CC-56212	5/16-18 x 2-1/2
GH-CC-38312	3/8-16 x 3-1/2

Swivel Foot Adjustable Spindle Assemblies

Copper-plated finish

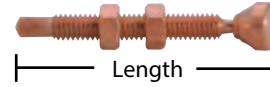

Part No.	Description
GH-SF-14214	1/4-20 x 2-1/4
GH-SF-56234	5/16-18 x 2-3/4
GH-SF-38200	3/8-16 x 2
GH-SF-38300	3/8-16 x 3
GH-SF-12300	1/2-13 x 3
GH-SF-12400	1/2-13 x 4

Flanged Washers for U-Bar Clamps

Zinc-plated finish



Part No.	Description
GH-FW-080	For 8 spindle
GH-FW-100	For 10 spindle
GH-FW-140	For 1/4 spindle
GH-FW-516	For 5/16 spindle
GH-FW-380	For 3/8 spindle
GH-FW-120	For 1/2 spindle
GH-FW-580	For 5/8 spindle

Neoprene Caps



Part No.	Description
GH-NC-140	For 1/4 spindle
GH-NC-516	For 5/16 spindle
GH-NC-380	For 3/8 spindle
GH-NC-120	For 1/2 spindle

Bolt Retainers

Zinc-plated finish



Part No.	Description
GH-BR-140	For 1/4 spindle
GH-BR-516	For 5/16 spindle
GH-BR-380	For 3/8 spindle
GH-BR-120	For 1/2 spindle
GH-BR-580	For 5/8 spindle



PART NO.	PAGE
101-A	1
101-AI	1
101-AIT	1
101-AT	1
101-ASS	1
101-B	4
101-H	9
101-J	9
101-JS	9
102-B	4
106-B	5
200-W	19
200-WH	19
200-WL	19
200-WLH	19
201	10
201-A	10
201-AI	10
201-AL	10
201-AR	10
201-ASS	10
201-B	13
201-BHB	13
201-BI	13
201-BS	13
201-BSI	13
201-BSS	13
201-BSM	13
201-I	10
201-L	10
201-R	10
201-SS	10
202-F	14
202-FL	14
203-F	14
203-FL	14
204-G	20
204-GB	20
204-GBL	20
204-GBLH	20
204-GL	20
220-WH	19
220-WLH	19
225-D	15
225-DHB	15
225-DI	15
225-DSM	15
225-DSS	15
301-A	21
301-B	21
302-D	22
302-F	22
302-FSS	22
303-EK	25
304-C	26
304-E	26
304-H	26
305-C	26
305-E	26
305-H	26
431	28
431-LUB	28
431-LUBSS	28
431-SS	28
451	29
451-LP	29
451-LPSS	29
451-SS	29
452	29
452-LP	29
452-LPSS	29
452-SS	29
701-C	35
701-D	35
701-K	35
702-C	35
702-D	35
702-K	35
10101-A	38
10247	8
10247-A	39

PART NO.	PAGE
10248	8
10249	8
10249-A	8
10250	8
10444	8
10448	8
11002-B	1
12002-B	1
12050	3
12050-A	38
12050-HB	3
12050-SM	3
12050-SS	3
12050-U	3
12050-UL	3
12055	3
12060	3
12065	3
12070	3
12075	3
12080	3
12085	3
12130	6
12130-A	38
12130-HB	6
12130-SM	6
12130-SS	6
12131	6
12132	6
12132-A	38
12133	6
12135	6
12136	6
12137	6
12138	6
12140	6
12141	6
12142	6
12143	6
12145	6
12146	6
12147	6
12148	6
12205	5
12265	7
12265-A	38
12265-SS	7
12270	7
12275	7
12275-A	38
12280	7
12285	7
12290	7
12295	7
12300	7
12305	7
12310	7
12315	7
12320	7
13002-B	1
13005	2
13005-HB	2
13005-SM	2
13005-SS	2
13007	2
13007-SM	2
13008	2
20235	19
20235-SS	19
20236	19
20300	11
20752-B	12
20800	11
20800-SS	11
20820	14
20820-A	39
21383	16
21385	18
21502-B	12
22005	10
22010	10

PART NO.	PAGE
22025	10
22030	10
22100	12
22105	12
22165	16
22170	16
22175	16
22180	16
22185	16
22190	16
22195	16
22200	16
22235	17
22502-B	12
25382	18
25383	17
30250	25
30282	22
30290	23
30292	23
30450	25
30509	27
30519	27
30607	24
30609	27
30619	27
36003	23
36003-A	40
36006	21
36010	24
36012	24
36020	23
36060	24
36070	21
36092	22
36202	26
36204	26
36204-SS	26
36205	26
36224	26
36225	26
36301-A	40
36330	25
36330-A	40
40323	28
40323-LUB	28
40323-LUBSS	28
40323-SS	28
40324	29
40334	29
40341	28
40341-LUB	28
40341-LUBSS	28
40341-SS	28
40344	29
40370	31
40370-LP	31
40371	29
40371-LP	29
40380	31
40820	28
40840	28
40870	28
43101	30
43101-LP	30
43110	30
43110-LP	30
43120	30
43120-LP	30
43150	30
43150-LP	30
43160	30
43160-LP	30
43810	30
43810-LP	30
50350	32
50360	32
50380	32
50385	32
50450	33
50480	33

PART NO.	PAGE
60130	34
60131	34
61352	33
70305	35
70310	35
70315	35
70505	35
70510	35
70515	35
70605	35
70610	35
70615	35
75027	36
75027-SM	36
75048	36
75078	36
80070	37
80325	37
80325-SS	37
BR-120	42
BR-140	42
BR-380	42
BR-516	42
BR-580	42
CC-10138	42
CC-14134	42
CC-38312	42
CC-56212	42
FC-10138	42
FC-12334	42
FC-14134	42
FC-14218	42
FC-38312	42
FC-38412	42
FC-56212	42
FC-56300	42
FW-080	42
FW-100	42
FW-120	42
FW-140	42
FW-380	42
FW-580	42
FW-516	42
NC-120	42
NC-140	42
NC-380	42
NC-516	42
SA-08034	42
SA-10118	42
SA-12300	42
SA-12412	42
SA-14112	42
SA-14134	42
SA-38300	42
SA-38400	42
SA-56200	42
SA-56212	42
SA-58500	42
SF-12400	42
SF-14214	42
SF-38300	42
SF-56234	42
YB-3130	41
YB-3145	41
YB-3160	41
YB-3730	41
YB-3745	41
YB-3760	41
YN-3130	41
YN-3145	41
YN-3160	41
YN-3730	41
YN-3745	41
YN-3760	41
YP-3130	41
YP-3145	41
YP-3160	41
YP-3730	41
YP-3745	41
YP-3760	41

Please call 800.989.5244 to request the full line catalog.

Our Valtra catalog features a wide range of Operating Accessories (Handles, Handwheels, Cranks, Levers, and Knobs), and Tooling Components. Modifications to standard parts and custom orders welcome.

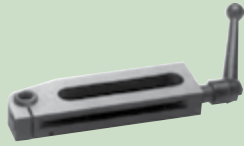

Bedding Support

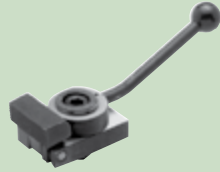

Cam Action Clamp



Forged Adjusta-Clamps



Adjustable Handles



Leveling Clamp

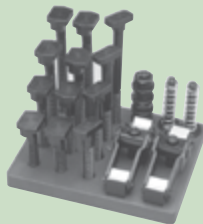

Economy Adapta-Clamp Kit



Handwheels

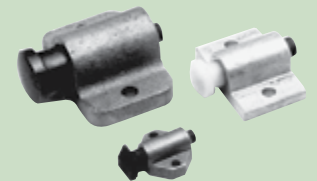

Spring Stops



Handknobs



Inserta Clamp



Speed Ball Handles



Crank Handles



Clamping Levers



Lifting Eyebolts



Leveling Pads



Heavy Duty Fixed Glides



T-Slot Bolts



Rotary T-Slot Bolts



Plain Eyebolts



T-Strap Bolts

Please call 800.989.5244 to request the full line catalog.

Multi-function, time saving Strong Hand[®] Clamps, Magnets, and Pliers are Quick Acting, so you save time and money by completing work setups faster.

Adjust-O Magnet Group

The magnets with the ON/OFF switch - Fast, Easy, Convenient.



Adjust-O Magnet Square
The Original ON/OFF Magnet



Mag-Level
Magnet Level with an ON/OFF Switch



Adjust-O Dual Switch Magnet
Heavy Duty 150 lbs. Force

Multi-Purpose Pliers & Vises



Round Tip Pliers
Improved Locking Mechanism



Pipe Pliers
The Easy Way to butt-weld pipes



3-Axis Fixture Vise
3-Axis Welding in One Setup

Welding Tables



Nomad™
Affordable, Fully Adjustable, Easily Movable



BuildPro™
Faster Fixturing, Consistent Results, Greater Productivity

The **4-IN-1** Clamp

Introducing the 4-IN-1 Clamping System. Strong Hand® has transformed the sliding arm clamp from a one dimensional to a **multi-purpose** clamp.

The 4-IN-1 Clamp Kit comes complete with the V-Pad & Extender Block accessories.



V-Pad



Extender Block

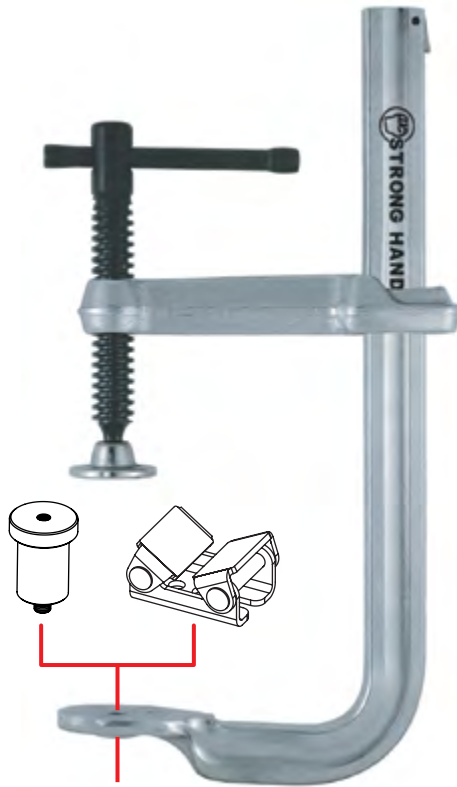

Threaded Hole

All models have a threaded hole to mount different accessories.

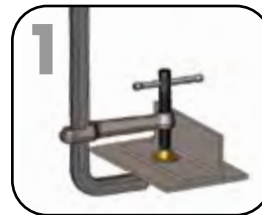

Standard

The Sliding Arm Clamp is 10x faster than a C-Clamp!



Pipe

Add the exclusive V-Pad to create a Pipe Clamp!



Spreader

Slide the clamp arm OFF and reverse to create a Spreader Clamp.

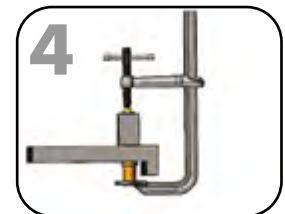

Step-Over

Add the Extender Block to create a Step-Over Clamp.



UF, UG & UM Models

Push the lever to slide the clamping arm ON & OFF.



UD Models

Remove the key ring to slide the clamping arm ON & OFF.



Heavy Duty Replaceable Pad
UM125-C3 & UM205-C3 only



Standard Swivel Pad
All models

Part No.	Description	Rail Sizes	Clamping Pressure
UD45-C3	UD45 4-1/2" Utility Clamp, V-Pad (#XDV) & Extender Block (#XDB1)	5/8 x 5/16	500 lbs.
UF65-C3	UF65 6-1/2" Utility Clamp, V-Pad (#XFV) & Extender Block (#XFB)	7/8 x 7/16	1,000 lbs.
UG85-C3	UG85 8-1/2" Utility Clamp, V-Pad (#XFV) & Extender Block (#XFB)	1" x 15/32	1,200 lbs.
UG125-C3	UG125 12-1/2" Utility Clamp, V-Pad (#XFV) & Extender Block (#XFB)	1" x 15/32	1,200 lbs.
UM85P-C3	UM85P 8-1/2" Utility Clamp, V-Pad (#XMV) & Extender Block (#XMB2)	1-3/16 x 9/16	2,400 lbs.
UM105P-C3	UM105P 10-1/2" Utility Clamp, V-Pad (#XMV) & Extender Block (#XMB2)	1-3/16 x 9/16	2,400 lbs.
UM125-C3	UM125 12-1/2" Utility Clamp, V-Pad (#XMV) & Extender Block (#XMB2)	1-3/16 x 9/16	2,400 lbs.
UM205-C3	UM205 20-1/2" Utility Clamp, V-Pad (#XMV) & Extender Block (#XMB2)	1-3/16 x 9/16	2,400 lbs.

All sliding arm clamps are made of heat treated alloy steel and nickel/chrome plated for strength and durability.

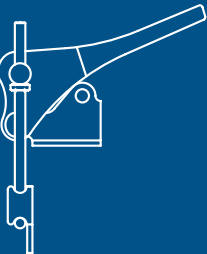
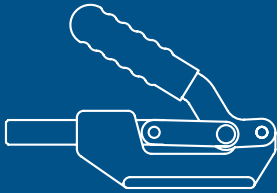
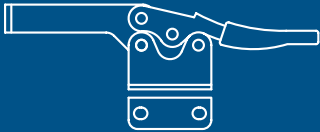
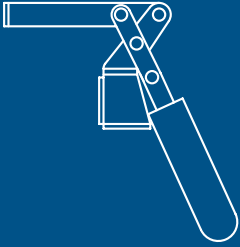
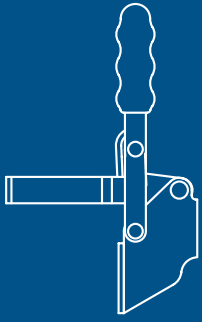

Good Hand Inc.

Toll Free
(800) 989 5244

Tel
(562) 949 8625

Fax
(562) 949 4875

Address
7141 Paramount Blvd.,
Pico Rivera, California, 90660

Web
www.goodhandinc.com

E-Mail
sales@valtrainc.com

QUALITY • DIVERSITY • ECONOMY