

Starrett®

PRECISION, QUALITY, INNOVATION

Since 1880



PRECISION, QUALITY, INNOVATION

Welcome to our new edition, Catalog 33. We remain as dedicated today to the making of great tools for our customers as we were when L.S. Starrett founded the company in 1880. He created a business and a brand that has become synonymous with precision, quality and innovation, backed by unmatched service and support.

We accomplish this by offering application-designed precision tools, saws, and custom solutions that optimize job and process performance. Our confidence hinges over 130 years of experience focusing on your needs and your success. We take great pride in manufacturing long-lasting, easy-to-use tools that provide consistent and reliable performance.

Today, Starrett offers five product categories: Precision Measurement Tools, Metrology Equipment, Granite-based Engineered Solutions, Saw Blades, and Jobsite and Shop Tools.

Whether you need to modify a standard tool, require assistance in selecting the best saw blade for your cutting application, or desire a custom solution for your business, we have the breadth of knowledge to assist you.

We are committed to providing you with complete solutions created for your exact needs. Problem solving is part of what we do every day. If the right tool for your application does not exist, contact us – we would appreciate the opportunity to build it.



D.A. Starrett

President and CEO



MICROMETERS

In the hands of a skilled operator, the precision micrometer is the most accurate hand-held tool available. When close measurements are necessary, the micrometer is the ideal tool for the job because measurement and reading are on the same axis and the anvil end is supported by a strong frame.

19



SLIDE CALIPERS

Our calipers are light, comfortable, easy-to-use, and constructed with features that have made Starrett slide calipers the machinist's first choice for many years.

89

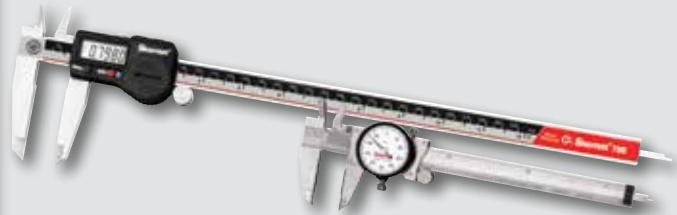

HEIGHT GAGES

Height gages measure the distance from a reference surface, such as a surface plate, to some feature of a part, and can do so with exceptional accuracy. We also offer a comprehensive range of scribes, attachments and accessories for all of your height gaging needs.

107



DEPTH GAGES

We offer a choice of depth products varying in form, complexity, cost and accuracy, from the most accurate depth micrometers (electronic, dial and vernier) to the less complex precise rule gages and combination rule gages.

123



INDICATORS AND GAGES

We offer a variety of each of the major classes: mechanical dial, electronic display, lever style test and back plunger. Indicator requirements are very specific and Starrett offers everything you need: a broad line of each indicator type, an extensive range of accessories to configure and position the gage, and as needed, an indicator-based, custom engineered solution.

133



PRECISION TOOLS



BORE GAGES

Our line of bore gages is extensive, with products available for a broad range of applications. Some are available with interchangeable measuring heads for different diameters or extensions for depth. They can have electronic displays (some with output), micrometer-type vernier scales or a dial (similar to an indicator).

203



TOOL SETS

We offer a selection of tool sets that combine basic tools such as a 0-1" micrometer, 0-6" caliper and a few other fundamental measuring tools in a single set for apprentices or beginners. Some are designed for the requirements of a type of application or are industry-specific.

221



DATA COLLECTION SYSTEMS

DataSure® Wireless Data Collection is a state-of-the-art system for real-time collection and recording of measurement data. From measurement to input, it reduces steps, saves time and can completely eliminate error in the data collection process. We also offer several newer technology products for wire-based data collection, SmartCable for single tools and the 4-Port Gage Multiplexer.

223



GAGE AMPLIFIERS, HARDNESS AND SURFACE TESTERS

We have added to and updated our tester line significantly in recent years. Our bench hardness testers range from relatively simple analog models to electronic versions with broad capabilities. We also offer several portable hardness testers, two new surface roughness testers, an electronic durometer, an ultrasonic thickness gage and a full range of test blocks and accessories.

231



SPECIAL GAGING

Standing out from other precision tool providers through our willingness to work directly with customers to design and manufacture custom tools for applications that standard products cannot perform. For over 50 years, we have provided solutions to industries including energy, aerospace, automotive, food packaging, high-technology plastics, medical components, and to NASA and other government agencies.

251

SQUARES

Invented by our founder, the combination square was our first product and today, our brand is considered to be the best available. This section offers a range of high quality solid squares, tri-squares specialty products and accessories that is especially broad and deep.

265

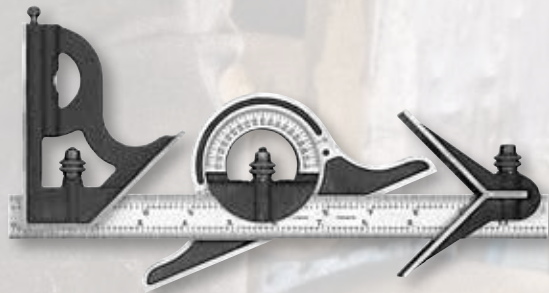

PRECISION RULES, STRAIGHT EDGES AND PARALLELS

Our comprehensive line offers a choice of temper, 10 English and 8 metric graduation styles with several width, thickness and length options and a full range of accessories and holders. Straight edges and parallels made with the same care and accuracy as our precision rules are also available.

283

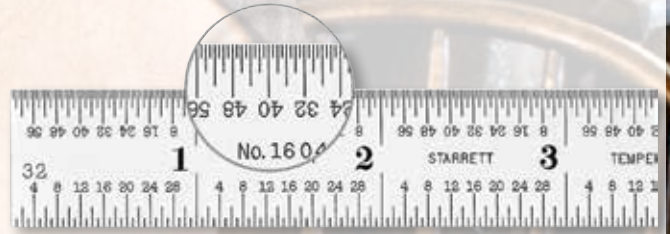

PROTRACTORS AND ANGLE MEASUREMENT

We offer a variety of tools with a sharply graduated 180° scales intersected by a movable blade, a bevel protractor, protractor/depth gages and special drill point gage. We also have available an indicator protractor head for use with custom engineered applications.

305



CALIPERS, DIVIDERS AND TRAMMELS

Manufacturing calipers and dividers since about 1890, we continue to build them with the same level of quality today. Even with many more options available today, these tools are still the best choice for many measurement transfer, scribing and other jobs. We also offer trammel heads, divider points and attachments.

311



HOLE AND SLOT GAGES

We offer several varieties of small hole gage sets as well as telescoping gages for larger holes. Our taper gages are inserted into a hole or slot, with the diameter determined by the reading on the tool's etched scale.

319



PRECISION TOOLS



FIXED GAGE STANDARDS

Fixed Gage Standards include a comprehensive choice of standard gages that quickly check dimensions on a variety of workpieces. They are very useful for in-process and final inspection. Products include pin gages, drill gages, sheet and wire gages, center gages, screw pitch gages, radius gages, ball and diameter gages, angle gages, thickness gages and feeler stock.

325



PRECISION SHOP TOOLS

This section offers quality tools that do not measure, but are needed frequently in manufacturing. Tools such as work positioning tools, scribers, punches, vises and lubricant are an integral part of any shop or manufacturing industry.

341



MACHINISTS' LEVELS

We offer a selection of machinists' levels to suit a variety of precision work typically required in industry. Our machinists' levels are manufactured with ground surfaces designed specifically for machine shop and tool room use.

369



STARRETT-WEBBER GAGE BLOCKS

We offer high-grade steel gage blocks for shop floor use, longer-lasting and non-corroding ceramic blocks. Top-of-the-line croblox[®] Chromium Carbide, are very stable, non-corrosive and have excellent wringability. A variety of sets are available in square- and rectangular-block versions. We also offer individual replacement blocks and a range of related accessories.

375



PRECISION GRANITE PRODUCTS

Products and services range from standard surface plates and metrology accessories to engineering collaboration for unique solutions and complex assemblies. Our skilled technicians build your product in our state-of-the-art, environmentally controlled manufacturing facility.

409

VISION SYSTEMS

Video-based measurement systems combine high-resolution images, powerful-intuitive software and precision mechanical platforms to deliver superb accuracy and repeatable measurement results for a wide range of precision measurement applications

423



VIDEO INSPECTION SYSTEMS

The KineMic™ video based microscopes are a family of versatile and affordable inspection and measurement systems.

445



OPTICAL COMPARATORS

Optical comparators provide a time tested, cost effective solution for non-contact measurement. Optical comparators are used for an exceptionally wide range of dimensional inspection and measurement applications.

449



SOFTWARE

Starrett offers multiple software and metrology readout solutions to meet the needs of Quality Departments, Engineering and Manufacturing alike.

475



MATERIAL TESTING AND FORCE MEASUREMENT

Turnkey system solutions for material testing, force analysis and force measurement. Our systems distinguish themselves from the competition by making it easy to create and perform a test, and manage test results. We offer a full range of test frames, software, load cell sensors, test fixtures and more.

481



PRECISION TOOLS



LASER MEASUREMENT

We offer the Profile360 for in-line measurement of rubber and plastic extrusions, roll-formed metal profiles, pipe, and shaped wire profiles. We have a suite of tire industry products for in-process and off-line measurement in tread extrusion, calendering, tire building, bulge and depression measurement, and cured tire inspection.

527

PRECISION GROUND FLAT STOCK AND DRILL ROD

We stock a full range of sizes in O1, A2, D2, A6, W1 and Low Carbon Steel. Specials can be produced in as little as 5 days at our North Carolina manufacturing facility. Starrett Ground Flat Stock and Drill Rod is of the highest quality, in fact we use it in the production of many of our own Precision Measuring Tools.

549

VOCATIONAL AND EDUCATIONAL

Our educational literature is used as a resource in the machinist's shop, the classroom or for the everyday end-user. It ranges from posters that can be hung in the workshop to booklets that explain how to utilize your Starrett tools. Pocket cards and memo pads are also available for those who need precise measurements while on the job or in the classroom.

571

REFERENCE TABLES

577

INDEX

593

Collaboration and Creative Thinking

**PRODUCES
REAL
SOLUTIONS**
for global industrial markets.



ABOUT STARRETT

FACTORIES AROUND THE WORLD



1-Athol, Massachusetts, USA
L.S. STARRETT COMPANY WORLD HEADQUARTERS



2-Laguna Hills, California, USA



3-Waite Park, Minnesota, USA



4-Cleveland, Ohio, USA

FACTORIES



A GLOBAL MANUFACTURER FOR OVER HALF A CENTURY

Starrett's success as a global manufacturer began in the 1950's with the establishment of facilities in Brazil and the United Kingdom. Today, Starrett has nine manufacturing locations worldwide: Brazil, The U.K., China, and six in the United States.

Most of the products in this catalog are made at a Starrett U.S. facility. The rest are sourced from one of our global locations.

Regardless of the country of origin, the Starrett name is your assurance of unmatched precision and quality. After more than 130 years, Starrett remains "The World's Greatest Toolmaker" – setting the continuing standard of excellence.

 Factories and Distribution Centers  Starrett Distribution Centers and Offices





5-Mount Airy, North Carolina, USA



6-Columbus, Georgia, USA



7-Itu, São Paulo, Brazil



8-Jedburgh, Scotland



9-Suzhou, China



CONTACT INFORMATION

CORPORATE HEADQUARTERS AND MAIN FACTORY

THE L.S. STARRETT COMPANY

121 Crescent Street
Athol, MA 01331-1915 U.S.A.
Telephone: (978) 249-3551
Fax: (978) 249-8495

U.S. DIVISIONS

STARRETT SAW DIVISION

1372 Boggs Drive
P.O. Box 1268
Mount Airy, NC 27030-1268
Telephone: (336) 789-5141
Fax: (336) 789-8160

STARRETT METROLOGY DIVISION

Starrett Kinematic Engineering, Inc.
26052 Merit Circle, Suite 103
Laguna Hills, CA 92653
Telephone: (949) 348-1213
Fax: (949) 582-8040

STARRETT CONSTRUCTION DIVISION

4130 Faber Place Drive, Suite 105
N. Charleston, SC 29405

STARRETT WEBBER GAGE DIVISION

24500 Detroit Road
Cleveland, OH 44145-2579
Telephone: (440) 835-0001
Fax: (440) 892-9555

STARRETT GRANITE DIVISION

Starrett Tru-Stone Technologies
P. O. Box 430
1101 Prosper Drive
Waite Park, MN 56387
Telephone: (320) 251-7171
Fax: (320) 259-5073

STARRETT LASER MEASUREMENT DIVISION

Starrett-Bytewise Measurement Systems
1150 Brookstone Centre Pkwy.
Columbus, GA 31904
Telephone: (706) 323-5142

INDUSTRIAL DISTRIBUTION

Ample stocks of Starrett products to meet your needs are maintained by leading industrial distributors worldwide.

Your Starrett distributors have a thorough knowledge of the Starrett line and can help you with your inquiries. They are readily available to provide you with quick and reliable support. Be sure to make use of their valuable services.

INTERNATIONAL LOCATIONS

BRAZIL

Starrett Indústria e Comércio Ltda.

Itu, São Paulo, Brazil
Telephone: 55 11 2118-8000
Fax: 55 11 2118-8003

SCOTLAND

The L.S. Starrett Company Ltd. Starrett Precision Optical Ltd.

Jedburgh, Scotland
Telephone: 44 (0) 1835 863501
Fax: 44 (0) 1835 863018

China

Starrett Tools (Suzhou) Company Limited

Suzhou, China
Telephone: 86 512 6741940
Fax: 86 512 67415697

Starrett (Asia) Pte Ltd. Singapore

Singapore
Telephone: +65 6365 1088
Fax: +65 6365 5125
starrett_asia@starrett.com.sg

BRANCH OFFICES AND WAREHOUSES

SALTILLO MEXICO

The L.S. Starrett Company
of Mexico S. de R.L. de C.V.
Saltillo, Coah, Mexico
Telephone: (844) 432-46-60
Fax: (844) 432-46-61

ARGENTINA

Starrett Argentina S.A.
Buenos Aires, Argentina
Telephone: 54 11 4756-6222
Fax: 54 11 4756-1144

GERMANY

Starrett GmbH
Schmitten/Taunus, Germany
Telephone: 49 6084 959510
Fax: 49 6084 959511

AUSTRALIA

The L.S. Starrett Company of Australia Pty. Ltd.
Seven Hills, Australia
Telephone: 61 2 9620 6944
Fax: 61 2 9620 6988



PRECISION

At Starrett, we understand precision. For generations, the precision that we build into our products has allowed our customers to ensure the quality of their products. Precision is something we take very seriously.

PRIMARY STANDARDS

To ensure accuracy, manufacturers must enforce strict quality control processes. This starts with applying primary standards for measurement and inspection. This will ultimately lead to consistent, reliable gaging results.

Precision gage blocks are the primary standards vital to dimensional quality control in the manufacture of interchangeable parts. These blocks are used for calibrating precision measuring tools and for setting numerous comparative type gages.

However, even gage blocks are held to their own level of higher standards: Grand Master Blocks.

ACCURATE REFERENCE SURFACES

Every linear measurement depends on an accurate reference surface from which final dimensions are taken.

Precision Granite Surface Plates provide the best reference plane for work inspection and layout prior to machining.

They are also ideal bases for making height measurements and gaging surfaces, parallelism, etc. A high degree of flatness, stability, overall quality and workmanship also make them ideal bases for mounting sophisticated mechanical, electronic and optical gaging systems.



ACCURACY

Starrett precision measuring tool accuracies are based on their traceability through our grand master gage blocks as certified by the National Institute of Standards and Technology (NIST).

Worldwide, no one else has produced the accuracy and stability of Starrett-Webber croblox® Grand Masters.

They were produced in 1955 out of chromium carbide material to an accuracy within one millionth of an inch (.0000254mm) and have been checked periodically by the National Bureau of Standards and the National Institute of Standards and Technology (NIST). They have remained stable over this period.

QUALITY

Starrett precision measuring products are inspected for accuracy with standards traceable to our grand master gage blocks. After a period of use, precision measuring tools require regular preventative maintenance, periodic calibration and, sometimes, repair.

Starrett offers calibration services at several of our facilities, each with different emphasis, capabilities and certificates as detailed below.

CALIBRATION AND REPAIR

STARRETT TOOLS AND GAGES – ATHOL, MA

- Calibration of Starrett Precision Tools
- Repair, refurbishing, and rebuilding of your Starrett tools by the same craftsmen who originally made them
- Accredited by A2LA in accordance with ANSI/NCSL Z540-1 and ISO/IEC 17025



Cert. No. 760.01



*STARRETT WEBBER GAGE DIVISION – CLEVELAND, OH

- Accredited calibrations of Linear Gage Blocks, Webber Height Gages and Standard Reference Bars, Angle Gage Blocks, True Squares, Optical Cubes, Optical Polygons and Optical Flats
- Accredited by NVLAP in accordance with ANSI/NCSL Z540-1 and ISO/IEC 17025*
- Calibrations also performed in accordance with ISO 10012-1 and former MIL-STD-45662A



Administered by N.I.S.T.
Lab Code 200038-0



*STARRETT GRANITE DIVISION – WAITE PARK, MN

- Calibration of granite surface plates, granite parallels, granite straight edges, granite tri-squares, granite angle plates and granite squares.
- Surface plate, granite metrology and accessory resurfacing
- Starrett Granite Surface Plates meet or exceed U.S. Federal Specification GGG-P-463c
- NIST-traceable calibration certificate provided that is ISO/IEC 17025* compliant
- ISO 9001:2000 certified and A2LA accredited per the ISO/IEC 17025* standard



Cert. No. 200.01



STARRETT METROLOGY DIVISION – LAGUNA HILLS, CA

- Factory or field calibration and repairs of Optical Comparator and Vision Systems performed by our factory trained experts
- First generation NIST traceable documentation for all calibration artifacts and standards

*STARRETT CALIBRATION SERVICES™ – DUNCAN, SC

321 Tucapau Road, PO Box 537, Duncan, SC 29334 | Tel.: 864-433-8407

- Fast, economical calibration for all major brands
- Repair of all major brands with parts in stock
- Accredited by A2LA in accordance with ANSI/NCSL Z540-1, and ISO/IEC 17025*



Cert. No. 1387.02



*Accreditations are site-specific and tool-specific. The Scope of Accreditation is available upon request to each location. Specifications and Certifications are subject to change.

CALIBRATION CERTIFICATE

(AVAILABLE BY REQUEST)

The Calibration Certificate includes the information that is on the SLC and the actual readings taken during the calibration of that tool. The certificate includes an environmental control statement, actual before and after data, standards used to perform calibration, applicable NIST test number, and uncertainty statement. The certificate conforms to the requirements of ANSI/NCSL Z540-1, ISO/IEC 17025 and ISO Guide 25.

STANDARD LETTER OF CERTIFICATION (SLC)

The Standard Letter of Certification certifies that the listed tool is a product of The L.S. Starrett Company and meets all applicable federal or manufacturing specifications. It has a unique serial number, tolerance parameter, and traceability to The National Institute of Standards and Technology (NIST).

Many of our tools are available with a redemption card for a Standard Letter of Certification. Their catalog numbers have the letters "W/SLC".



INNOVATION

NEW PRODUCTS

Product and technology innovation has been at the core of The L. S. Starrett Company since our inception. The restless, creative energy of our founder, dedicated to "continuous improvement" long before that phrase came into common usage, is as much a part of our company in the 21st century as it was in the 19th.

The table below lists products we have added to our Precision Tool Catalog since its last printing.

Beyond catalog products, we devote significant resources to developing highly innovative, application-focused solutions, as described on the following pages.

| New Product Summary | Page |
|---|------|
| T444.1 Outside Micrometers | 31 |
| 430 Indicating Micrometers | 73 |
| EC799 Electronic Micrometers | 91 |
| 3202 Dial Calipers | 98 |
| 3754 Electronic Height Gages | 112 |
| 258 Digi-Check™ Electronic Height Gage | 118 |
| 3259-AC Digital Height Gage Scriber Carrier Holder | 121 |
| 3809, 3809 Dial Test Indicators | 140 |
| 3908, 3909 Dial Test Indicators | 140 |
| 2900 Electronic Indicators | 170 |
| 2700 Backlight Indicators | 171 |
| 2700 Group 1 Digital Indicators | 174 |
| 3900 Electronic Indicators | 174 |
| 3670 Dial Indicator Stands | 175 |
| 781BXT AccuBore® Electronic Bore Gages with Output | 204 |
| 770BXT Electronic Bore Gages with IP67 Protection (with output) | 207 |
| 3089 Bore Gage Setter | 213 |
| RMS Remote Display and Probes | 233 |
| 3814 Digital Replacement for Bench Hardness Tester | 237 |
| SR160 Surface Roughness Testers and Accessories | 245 |
| C636MEC-500 Steel Rule | 296 |
| Waterless Surface Plate Cleaner Wipes | 421 |
| HDV500 Digital Video Comparator | 440 |
| VB300 Vertical Bench-Top Optical Comparator | 456 |
| TOV2 Optical Comparator Telecentric Video Adapter | 471 |
| L1 Systems | 500 |
| FMM Digital Force Testers | 505 |
| Digital Force Gages | 516 |
| DFG Digital Force Controller | 517 |
| MTL Manual Testers | 520 |
| MTH Manual Testers | 521 |
| Profile360™ - G4 | 528 |
| Off-Line Profilometer 3D (3DP) | 540 |
| Tire360 | 544 |
| GEO-360 | 545 |



T444.1XRL-1



EC799B-6/150



3202-6



DFC-100



HDV500



3900-5

2700-800



Granite Surface Plate Cleaner Wipes



3754-12/300



Tire360



FMM-110X



INNOVATION

APPLICATION-FOCUSED CUSTOM SOLUTIONS

WHEN YOU HAVE A SPECIAL MEASUREMENT PROBLEM, WE WILL HELP YOU FIND THE SOLUTION.

One way Starrett stands out from other precision tool providers is our willingness to work directly with customers to develop custom tools.

Over 50 years, Starrett Special Gage has developed and built thousands of innovative custom measuring solutions. Customers include the energy, aerospace, automotive, food packaging, high-technology plastics and medical components industries as well as NASA and the military.

Even with our broad catalog of products, some jobs require a custom solution. After we determine that no "off-the-shelf" product is applicable, our engineers begin a dialog with the customer to develop a custom tool for the specific task. Through a process of consultation, design, prototype machining and testing, we develop a specification to the full satisfaction of our customer.

Similarly, the Starrett Metrology and Starrett Tru-Stone Granite Technologies Divisions work interactively with customers to create custom solutions utilizing their specific expertise and technologies.

At the conclusion of the process, something that could not be measured is measured, and a difficult problem is transformed into an innovative, often elegant solution.

THE CUSTOM SOLUTIONS DEVELOPMENT PROCESS

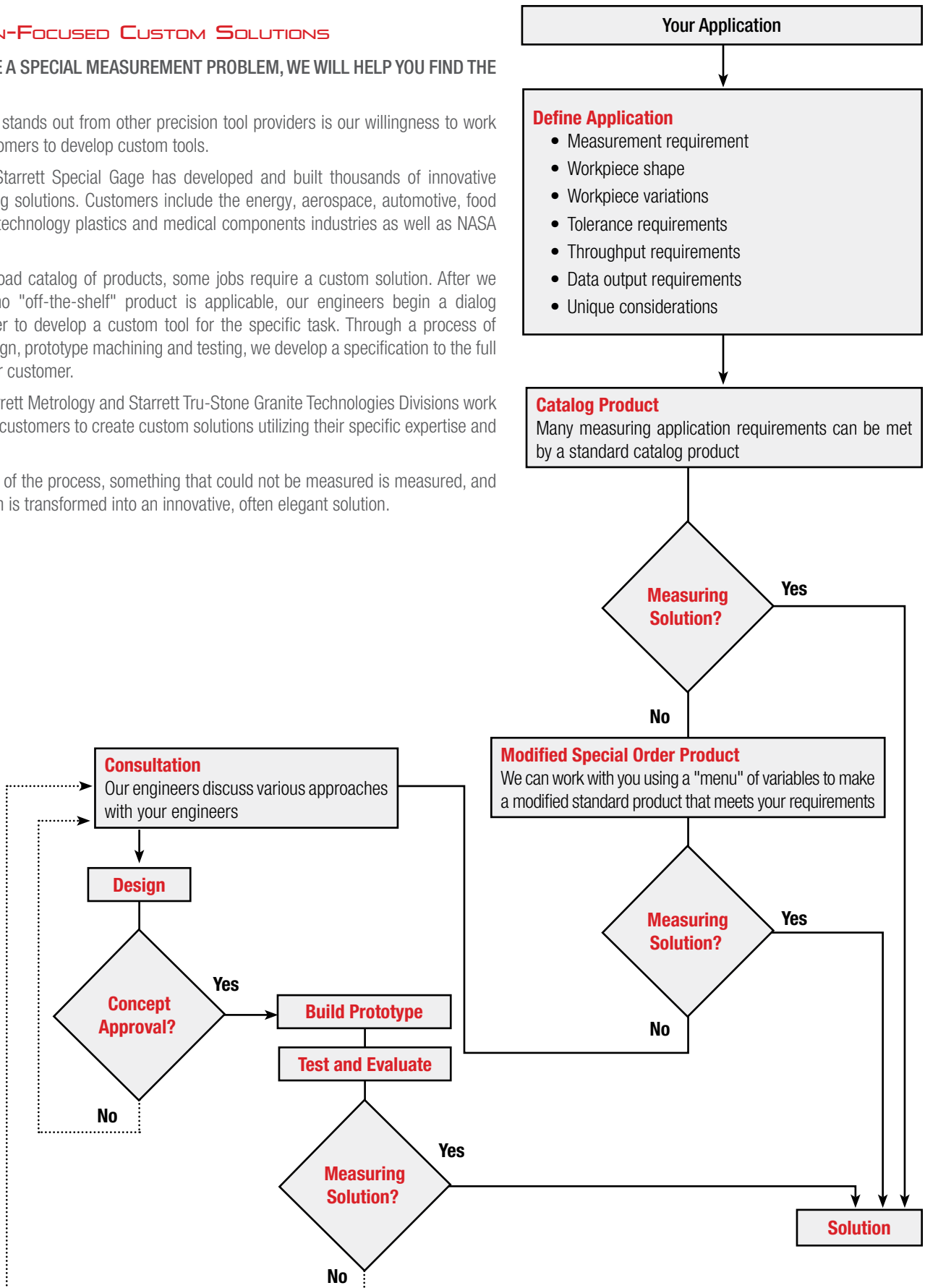

CUSTOM ENGINEERED SOLUTIONS

HANDHELD TOOLS AND GAGES

An interactive process between customer and Starrett engineering staffs created a gage that measures the diameter of hot steel flat stock while in the heat treatment process. An accurate measurement takes only two seconds of contact, reducing radiant heat transfer and part spoilage.

Its electronic indicator locks the reading in the display for safe reading and is accurate to within $\pm.003$ ".



ENGINEERED METROLOGY SYSTEMS

This application was custom developed with vision and touch probe sensors. As is the case with many recent systems, two or even three sensors are part of the custom solution.

The Starrett Metrology Division works closely with customers to find solutions for complex applications on a regular basis. Their expertise is as important to the solution as the excellence of our system hardware.



CUSTOM GAGE FIXTURES

We have worked with many customers to develop a gage to measure a specific food container, some with lids that must fit precisely – not too tight or loose. These containers are a perfect example of something that defies measurement with a standard tool.

The gage below uses pneumatics to withdraw probes for fast, easy and accurate placement and unloading.



GRANITE-BASED ENGINEERED SOLUTIONS

A medical devices manufacturer could not reliably measure a moving tube on a complex 7-axis laser micro machining system because of persistent vibration.

After extensive design consultation with our Starrett Granite Division, the vibration-dampening attributes of granite stabilized beam delivery, allowing measurement of the tubes at a molecular level.



GENERAL INFORMATION

SPECIFICATIONS AND AVAILABILITY

The information and specifications in this catalog were accurate at the time of publication. Specifications and availability of products, however, are subject to change without notice.

QUALITY ASSURANCE

Starrett tools are made to the highest standard of quality and workmanship. We want every tool in the hands of our customers to be accurate and satisfactory. If any tool is found not to be of Starrett quality, please contact our customer service department to arrange a return of that tool. Any tool proved to be defective in material or workmanship will, at our discretion, be repaired or replaced at no charge.

Please note that we cannot replace or give credit for tools that have been improperly used, stamped or mutilated, or tools that have been altered or repaired by personnel not authorized by The L.S. Starrett Company. We will be pleased to quote a price to repair such tools.

ACCURACY

At the time of manufacture, Starrett precision measuring tools meet or exceed accuracy and performance requirements of national and international standards, and are traceable to the United States National Institute of Standards and Technology.

STARRETT VALUE

No manufacturer's precision tools are guaranteed to work for life, regardless of the use or abuse they receive. It is worthy to note, however, that we at The L.S. Starrett Company regularly service and repair our precision measuring tools that have been passed from generation to generation. You can count on Starrett for full value.

REPAIR AND CALIBRATION

We offer expert repair and calibration services at several of our facilities as noted on previous pages. Please contact the appropriate facility to arrange for these services.

CUSTOM SOLUTIONS AND SPECIAL ORDERS

As noted, we have built thousands of special tools to meet the unique needs of our customers, and we welcome the opportunity to work with you to meet your special requirements. Please contact our Special Gage Division at (978) 249-3551, or contact the international location that is your supplier.

HOW AND WHERE TO ORDER STARRETT PRODUCTS

Starrett tools are sold through authorized distributors. Orders should be placed with a Starrett distributor in your area. Please check our website or contact us for assistance in locating your nearest distributor.

Please note that we do not list distributors for our Metrology Products (Vision Systems and Optical Comparators) due to their technically complex and application-specific nature. Please contact our Metrology Division in Laguna Hills, CA at (949) 348-1213 for assistance in finding the best distributor for your application, product and location.

PRODUCT PRICE

Please contact your distributor for prices of Starrett products. In most cases, we do not quote prices directly to customers. From time to time, we offer promotions with stated prices valid for a defined period. Such promotions are listed on our website and detailed in printed promotional material. If you require help finding a participating distributor, please contact us.

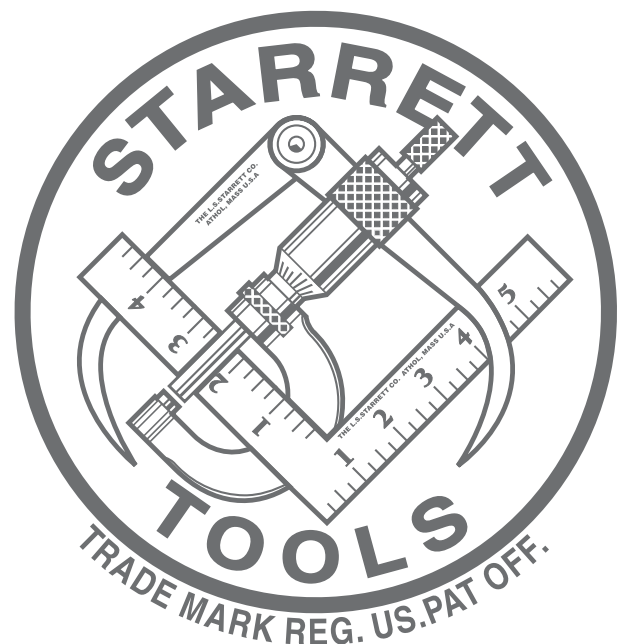



MICROMETERS

STARRETT RELIABLE PRECISION MICROMETER DESIGN AND MANUFACTURING FEATURES

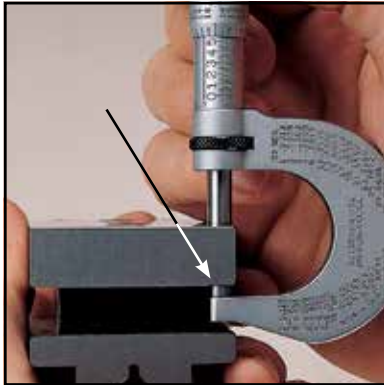

Tapered Frame – a Starrett original feature – permits measurements in narrow slots and tight places. Standard with Starrett.

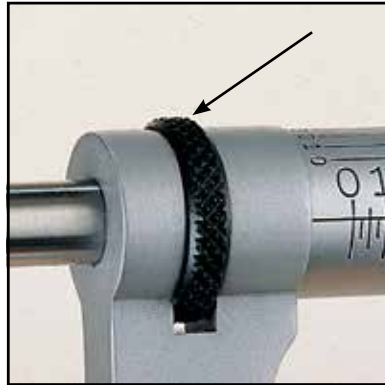

Ring-type lock nut convenient to use. Permits locking of spindle at any reading.

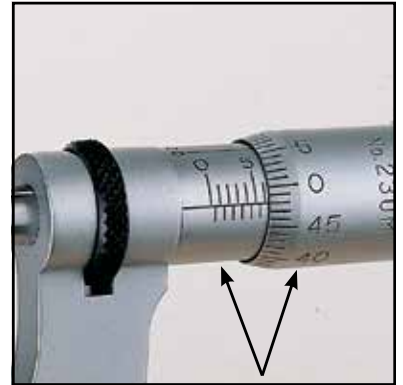

Easy to read with distinct black figures against satin-chrome finish.



Staggered graduations, advanced design, a Starrett original feature. Quick reading figures on inch reading micrometers. Every graduation numbered for quick, positive identification. Easy to read with distinct black figures against satin-chrome finish.



Friction thimble, smooth uniform pressure independent of "feel."



Ratchet stop/speeder for consistent measurements and to speed opening or closing of tool.

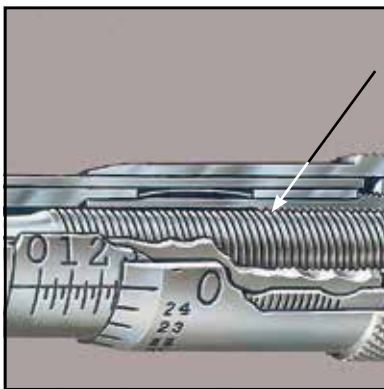

Extra Hard Threads with Extreme Lead Accuracy. Special high carbon steel gives harder threads which are hardened, stabilized, and precision ground from the solid to ensure long and accurate life.

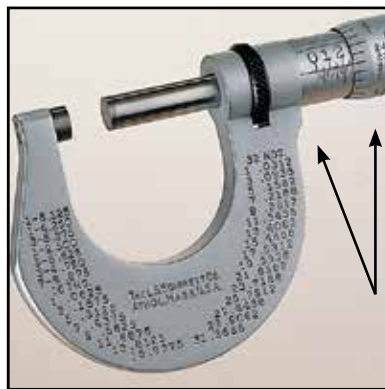

Balanced design; plus no-glare satin chrome finish makes the tool easy to hold and read, as well as resistant to stains, corrosion and wear.

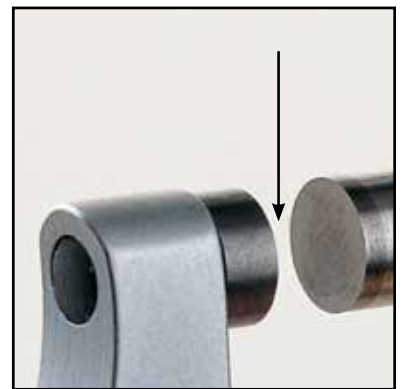

Micro-Lapped "Mirror" Finish on the measuring faces – a Starrett original feature that ensures more accurate measurements. Available with carbide faces or hardened, high-carbon steel faces.

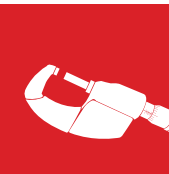

MICROMETER QUALITY AND ACCURACY

Product quality and accuracy cannot be valid unless referenced to a quality and accuracy standard.

All Starrett precision measuring tool standards meet or exceed accuracy and performance specifications of national and international standards and are traceable to the National Institute of Standards and Technology.

The Starrett Company does not rely on statistical sampling inspection. Every precision measuring tool is individually inspected.

All Starrett micrometers have the same accurate heads as outlined in the chart. Inaccuracies because of size can be minimized if the tools are set accurately to standard, and measurements are carried out in a similar position with similar pressure.

HOW TO ADJUST STARRETT MICROMETERS

Adjustments to Starrett Micrometers are rarely needed; however, if it becomes necessary, they can be readily adjusted in two easy operations as follows:



1. If any play should develop in the spindle screw threads due to wear of the spindle nut after long use, first back off the thimble, insert the spanner wrench in the slot of the adjusting nut and tighten just enough to eliminate play. Illustration shows how easily this is done.

2. After carefully cleaning all dirt or grit from the measuring faces of anvil and spindle, bring them together and insert the spanner wrench in the small slot of the sleeve. Then turn the sleeve until the line on the sleeve coincides with the zero line on the thimble as shown.

| Starrett Micrometer Accuracy Standards (Unless Otherwise Noted on the Catalog Page) | | | |
|--|-------|---------|----------|
| Type | Range | Readout | Accuracy |
| Mechanical | 1" | .001" | ±.0001" |
| | 1" | .0001" | ±.00005" |
| | 25mm | 0.01mm | ±0.002mm |
| | 25mm | 0.001mm | ±0.002mm |
| Electronic | 1" | .00005" | ±.0001" |
| | 25mm | 0.001mm | ±0.002mm |

KEY TO STARRETT MICROMETER NUMBERING SYSTEM

Key to Starrett Micrometer Numbering System

Prefixes

| | |
|---|--|
| R | Reverse Reading |
| S | Micrometer Set |
| T | .0001" Reading |
| V | 0.001mm or 0.002mm Reading, as specified |

Suffixes

| | |
|-------|--------------------------------------|
| F | Friction Thimble |
| L | Lock Nut |
| M | Metric |
| N | Non-Rotating |
| P | Plain |
| R | Ratchet Stop |
| S | Speeder |
| TN | Threaded Hub and Check Nut |
| W/SLC | Standard Letter of Certification |
| X | Micro-lapped Carbide Measuring Faces |
| Z | With Case |
| ZZ | Case Only |

MEASURING TIPS FROM OUR EXPERIENCE

- Most obvious to everyone is to keep the work to be measured and the micrometer anvil and spindle faces clean.
- For very fine measurements, the micrometer should be set to zero or to a standard by your "feel", by the friction thimble, or by the ratchet, whichever you will be using.
- The most popular micrometer option has been the ratchet speeder because it does three things well: it speeds opening and closing, it applies uniform pressure from the ratchet, and it allows for using the thimble for individual "feel".
- The speeder is helpful because it takes forty turns to cover the range of a typical English-reading tool and fifty turns to cover the range of a metric-reading tool.
- Large micrometers especially should be set to a standard in the same approximate position in which they will be used, that is, vertical or horizontal, to minimize any frame flexure influence.
- Too much speed in approaching the work will result in an inaccurate measurement.
- If the micrometer has been set to a flat standard, you can get approximately .0001" (0.0025mm) difference when measuring over a round because the same pressure is being applied to a point or line contact.
- Carbide or hardened steel measuring faces are a matter of choice. Carbide wears longer but many craftsmen think they get a better "feel" with highly finished steel measuring surfaces.
- Insulating pads on micrometers are a matter of personal preference. With the Starrett balanced micrometer design, there is no need for insulation. Insulation from hand heat is usually more beneficial on long sections, such as end measuring rods.



HOW TO READ A STARRETT MICROMETER

GRADUATED IN THOUSANDTHS OF AN INCH

.001"

The pitch of the screw thread on the spindle is 40 threads per inch. One revolution of the thimble advances the spindle face toward or away from the anvil face precisely 1/40" or .025 inches.

The reading line on the sleeve is divided into 40 equal parts by vertical lines that correspond to the number of threads on the spindle. Therefore, each vertical line designates 1/40" or .025 inches. Lines vary in length for easy reading. Every fourth line, which is longer than the others, designates a hundred thousandth. For example: the line marked "1" represents .100" and the line marked "2" represents .200", etc.

The beveled edge of the thimble is divided into 25 equal parts with each line representing .001" and every line numbered consecutively. Rotating the thimble from one of these lines to the next moves the spindle longitudinally 1/25 of .025", or .001". Rotating two divisions represents .002", etc. Twenty-five divisions indicate a complete revolution of .025" or 1/40 of an inch.

To read the micrometer in thousandths, multiply the number of vertical divisions visible on the sleeve by .025", and to this add the number of thousandths indicated by the line on the thimble which coincides with the reading line on the sleeve.

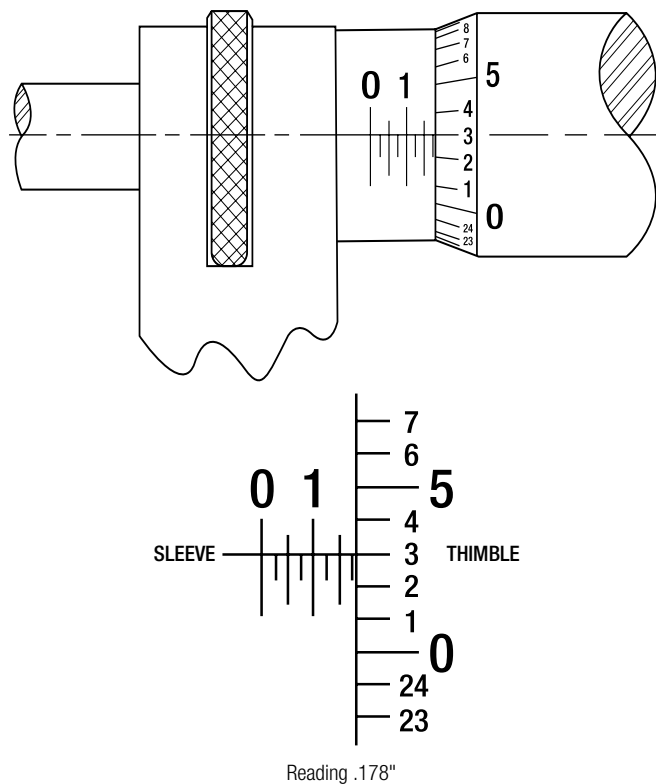

EXAMPLE:

The "1" line on sleeve is visible, representing 100"
 There are 3 additional lines visible, each representing .025"; 3 x .025" = .075
 Line "3" on the thimble coincides with the reading line on the sleeve,
 each line representing .001"; 3 x .001" = .003"
 The micrometer reading is 178"

GRADUATED IN TEN-THOUSANDTHS OF AN INCH

.0001"

Starrett micrometers graduated in ten-thousandths of an inch read like micrometers graduated in thousandths, except that an additional reading in ten-thousandths is obtained from a vernier scale on the sleeve.

The vernier consists of ten divisions on the sleeve, which occupy the same space as nine divisions on the thimble (Fig. B). Therefore, the difference between the width of one of the ten spaces on the vernier and one of the nine spaces on the thimble is one-tenth of a division on the thimble, or one ten-thousandth (.0001").

To read a ten-thousandths micrometer, first obtain the thousandths reading, then see which of the lines on the vernier coincides with a line on the thimble. If it is the line marked "1" on the sleeve, add one ten-thousandth, if it is the line marked "2", add two ten-thousandths, etc.

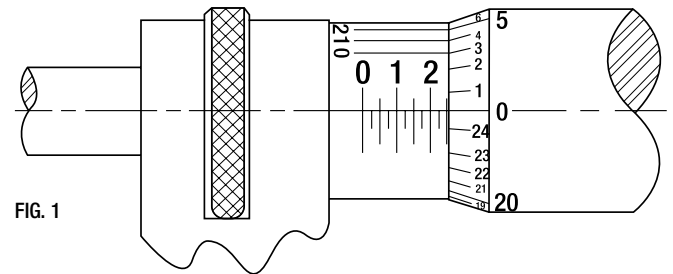

FIG. 1

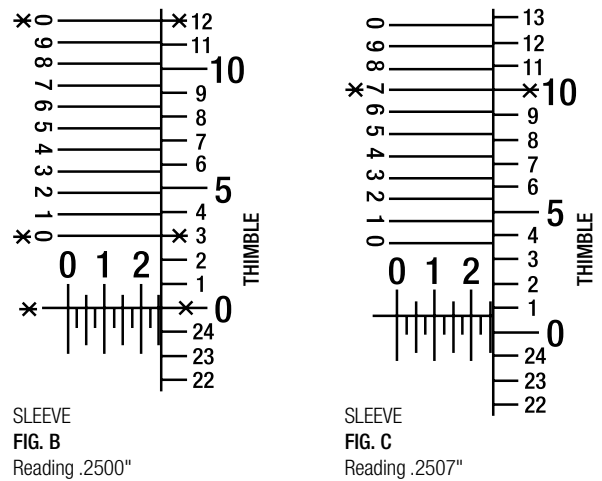

FIGURE C – READING .2507"

The "2" line on sleeve is visible, representing 200"
 There are two additional lines visible, each representing .025" 050"
 The reading line on the sleeve lies between the "0" and "1" on the
 thimble indicating that a vernier reading must be added
 The "7" line is the only line on the vernier that coincides with a line on
 the thimble, representing 7 x .0001" = .0007"
 The micrometer reading is 2507"



GRADUATED IN HUNDREDTHS OF A MILLIMETER

0.01MM

The screw head pitch is one-half millimeter (0.5mm). One revolution of the thimble advances the spindle face toward or away from the anvil face precisely 0.5mm.

The reading line on the sleeve is graduated above the line in millimeters (1.0mm) with every fifth millimeter being numbered. Each millimeter is also divided in half (0.5mm) below the reading line. Two revolutions of the thimble to advances the spindle 1.0mm.

The beveled edge of the thimble is divided into fifty equal parts, with each line representing 0.01mm and every fifth line being numbered. Rotating the thimble from one of these lines to the next moves the spindle longitudinally 0.01mm; rotating two divisions represents 0.02mm, etc.

To read the micrometer, add the number of millimeters and half-millimeters visible on the sleeve to the number of hundredths of a millimeter indicated by the thimble graduation indicated by the reading line.

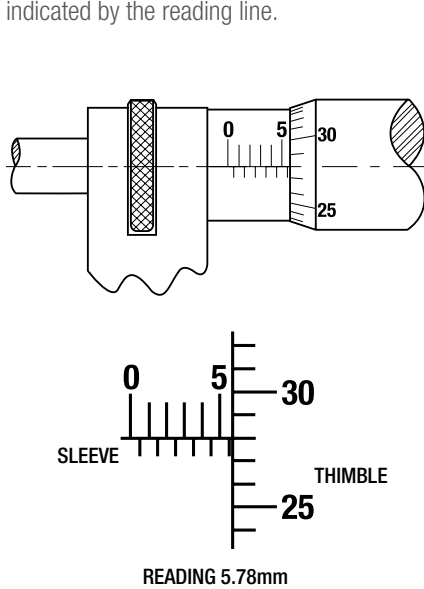

EXAMPLE:

The 5mm sleeve graduation is visible 5.00mm
 One additional 0.5mm line is visible on the sleeve 0.50mm
 Line 28 on the thimble coincides with the reading line on the sleeve, so $28 \times 0.01\text{mm} = 0.28\text{mm}$
 The micrometer reading is 5.78mm

GRADUATED IN TWO-THOUSANDTHS OF A MILLIMETER

0.002MM

Metric vernier micrometers graduated in 0.002mm are used like those graduated in hundredths of a millimeter (0.01mm), except that an additional reading in two-thousandths of a millimeter (0.002mm) is obtained from a vernier scale on the sleeve.

The vernier consists of five divisions on the sleeve, which occupy the same space as nine divisions on the thimble (Fig. B). Therefore, the difference between the width of one of the five spaces on the vernier and one of the nine spaces on the thimble is one-fifth or two-tenths of a division on the thimble, or two-thousandths (0.002mm).

To read a 0.002mm micrometer, first obtain the hundredth of a millimeter (0.01mm) reading, then see which of the lines on the vernier coincides with a line on the thimble. If it is the line marked "2" add 0.002mm, if it is the line marked "4" add 0.004mm, etc.

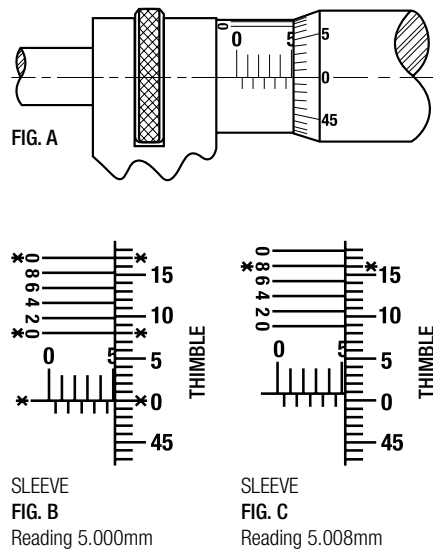

FIGURE C – READING 5.008mm

The 5mm sleeve graduation is visible 5.000mm
 No additional lines on the sleeve are visible 0.000mm
 The reading line on the sleeve lies between zero and the first line on the thimble, indicating that a vernier reading must be added.
 Line 8 on the vernier is the only line that coincides with a line on the thimble 0.008mm
 The micrometer reading is 5.008mm

GRADUATED IN ONE-THOUSANDTH OF A MILLIMETER

0.001MM

Reading a 0.001mm micrometer is exactly like reading a 0.002mm micrometer except that there are ten divisions on the vernier occupying the same space as nine divisions on the thimble (Fig. B). Therefore, the difference between the width of one of the spaces on the vernier and one of the nine spaces on the thimble is one-tenth of a division on the thimble, or one-thousandth (0.001mm).

First obtain the hundredth of a millimeter (0.01mm) reading. Next, see which of the lines on the vernier coincides with a line on the thimble. If it is the first line add

0.001mm to the reading, if it is the second line add 0.002mm, etc. Only every second vernier line is numbered on a 0.001mm reading tool because of space congestion.

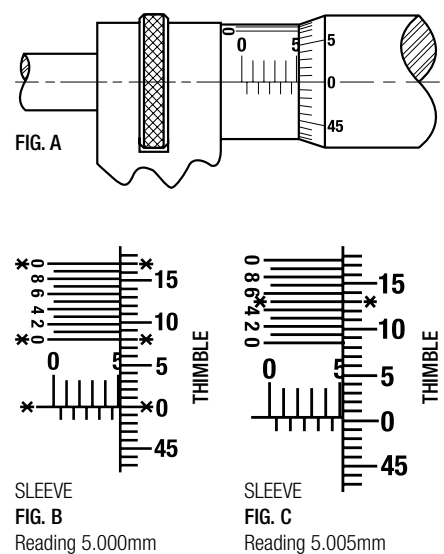

FIGURE C – READING 5.005mm

The 5mm sleeve graduation is visible, representing 5.000mm
 No additional lines on the sleeve are visible ... 0.000mm
 The reading line on the sleeve lies between zero and the first line on the thimble, indicating that a vernier reading must be added
 Line 5 on the vernier is the only line that coincides with a line on the thimble 0.005mm
 The micrometer reading is 5.005mm



ELECTRONIC MICROMETERS

795.1 ELECTRONIC MICROMETERS (WITH OUTPUT)

0-4"/0-100MM

796.1 ELECTRONIC MICROMETERS (WITHOUT OUTPUT)

0-4"/0-100MM

The expanded 795.1 and 796.1 Micrometer offering now includes measuring ranges up to 4" (100mm). All are IP67 protected against coolant, water, chips, dirt and dust. The 795.1 is equipped with an RS232 output port and is ideal for use with DataSure® Wireless Data Collection Systems or Multiplexer Inupt. Sets available upon request.

FEATURES AND SPECIFICATIONS



- Large, easy-to-read .275" (7mm), high-contrast LCD digital readout
- Starrett no-glare satin chrome finish on thimble and sleeve
- Balanced and tapered frame
- Extremely hard and stable one-piece spindle
- Micro-lapped carbide measuring faces
- Auto OFF after 20 minutes of nonuse
- Inch/millimeter conversion on English versions
- Measurement HOLD button
- Zero at any position
- Retain and return to true zero reading
- Resolution: .00005" (0.001mm)
- Accuracy: $\pm .0001$ " ($\pm .002$ mm)

| 795.1 Electronic Micrometers with Output | | | | | | |
|---|-------|---|---|---|-------|-------------------|
| Friction Thimble, Spindle Lock, Shell and Thimble Inch Grads. | EDP | Ratchet Stop, Lock Nut, Shell and Thimble Inch Grads. | EDP | Ratchet Thimble, Spindle Lock, Shell and Thimble Metric Grads.* | EDP | Range |
| Cat. No. | | Cat. No. | | Cat. No. | | |
| 795.1XFL-1 | 01100 | 795.1XRL-1 | 01108 | 795.1MXRL-25 | 01112 | 0-1" and 0-25mm |
| 795.1XFL-2 | 01101 | 795.1XRL-2 | 01109 | 795.1MXRL-50 | 01113 | 1-2" and 25-50mm |
| 795.1XFL-3 | 01102 | 795.1XRL-3 | 01110 | 795.1MXRL-75 | 01114 | 2-3" and 50-75mm |
| 795.1XFL-4 | 01103 | 795.1XRL-4 | 01111 | 795.1MXRL-100 | 01115 | 3-4" and 75-100mm |
| 796.1 Electronic Micrometers without Output | | | | | | |
| 796.1XFL-1 | 01104 | 796.1XRL-1 | 01116 | 796.1MXRL-25 | 01120 | 0-1" and 0-25mm |
| 796.1XFL-2 | 01105 | 796.1XRL-2 | 01117 | 796.1MXRL-50 | 01121 | 1-2" and 25-50mm |
| 796.1XFL-3 | 01106 | 796.1XRL-3 | 01118 | 796.1MXRL-75 | 01122 | 2-3" and 50-75mm |
| 796.1XFL-4 | 01107 | 796.1XRL-4 | 01119 | 796.1MXRL-100 | 01123 | 3-4" and 75-100mm |
| Sets | | | | | | |
| Cat. No. | EDP | Range | Description | | | |
| S795.1AXFLZ | 72534 | 0-3" (0-75mm) | Electronic micrometer set (set of 3), includes 795.1XFL-1, 795.1XFL-2, 795.1XFL-3 | | | |
| S795.1BXFLZ | 72535 | 0-4" (0-100mm) | Electronic micrometer set (set of 4), includes 795.1XFL-1, 795.1XFL-2, 795.1XFL-3, 795.1XFL-4 | | | |
| Cables and Accessories | | | | | | |
| Cat. No. | EDP | Description | | | | |
| 795.1SCM | 01124 | SmartCable to multiplexer | | | | |
| 795.1SCKB | 01125 | USB cable to PC (In focused window) | | | | |
| 795.1SCU | 01126 | SmartCable with USB keyboard output | | | | |
| PT99492 | 65650 | Two 3-Volt Batteries, CR2032 | | | | |

*Metric Only

All 795.1 and 796.1 Micrometers include a protective case. All except 1" and 0-25mm sizes furnished with standards.



IP PROTECTION

An IP number is composed of two numbers, the first referring to protection against solid objects and the second against liquids.



First number 6: Totally protected against dust

Second number 7: Protection against submersion in water under standardized conditions of pressure for 30 minutes

All 795.1 and 796.1 Micrometers include IP67 protection

ELECTRONIC MICROMETERS

3732 ELECTRONIC MICROMETERS (WITHOUT OUTPUT)

0-6"/0-150MM

The 3732 Electronic Micrometer is a full-featured precision measuring tool built with customary Starrett quality and workmanship. The 3732 includes a large, easy-to-read, high contrast LCD digital readout for clear readings. With its automatic OFF functionality, smooth friction thimble for uniform pressure, and balanced frame design, the 3732 provides comfortable and accurate measuring.

3732 Inch/Metric Micrometers without Output

| Cat. No. | EDP | Range in | Approx. mm | Resolution | | Accuracy | |
|-----------|-------|-------------|------------|------------|-------|-----------|---------|
| | | | | in | mm | in | mm |
| 3732XFL-1 | 12268 | 0-1 | 0-25.4 | 0.0001 | 0.001 | ± 0.0001 | ± 0.002 |
| 3732XFL-2 | 12269 | 1-2 | 25.4-50.8 | 0.0001 | 0.001 | ± 0.0001 | ± 0.003 |
| 3732XFL-3 | 12270 | 2-3 | 50.8-76.2 | | | | |
| 3732XFL-4 | 12271 | 3-4 | 76.2-101.6 | 0.0001 | 0.001 | ± 0.00015 | ± 0.004 |
| 3732XFL-5 | 12272 | 4-5 | 101.6-127 | 0.0001 | 0.001 | ± 0.00015 | ± 0.004 |
| 3732XFL-6 | 12273 | 5-6 | 127-152.4 | | | | |

3732 Metric/Inch Micrometers without Output

| Cat. No. | EDP | mm | Approx. in | mm | | in | |
|---------------|-------|---------|-------------|-------|--------|---------|----------|
| | | | | mm | in | mm | in |
| 3732MEXFL-25 | 12274 | 0-25 | 0-.984 | 0.001 | 0.0001 | ± 0.002 | ± 0.0001 |
| 3732MEXFL-50 | 12275 | 25-50 | .984-1.968 | 0.001 | 0.0001 | ± 0.003 | ± 0.0001 |
| 3732MEXFL-75 | 12276 | 50-75 | 1.968-2.953 | | | | |
| 3732MEXFL-100 | 12277 | 75-100 | 2.953-3.937 | 0.001 | 0.0001 | ± 0.004 | ± 0.0001 |
| 3732MEXFL-125 | 12278 | 100-125 | 3.937-4.921 | 0.001 | 0.0001 | ± 0.004 | ± 0.0001 |
| 3732MEXFL-150 | 12279 | 125-150 | 4.921-5.905 | | | | |

3732 Inch/Metric Micrometer Sets without Output

| Cat. No. | EDP | in | mm | Description |
|------------|-------|------------|-----------------------|---|
| S3732BXLZ | 12726 | 0-1 to 3-4 | 0-25.4 to 76.2-101.6 | 0 to 4 inch set of four micrometers in metal case |
| S3732CXFLZ | 12727 | 0-1 to 5-6 | 0-25.4 to 101.6-152.4 | 0 to 6 inch set of six micrometers in metal case |

3732 Micrometer Accessories

| Part No. | EDP | Description |
|----------|-------|--|
| PT99492 | 65650 | CR2032 3-volt battery for 3732 Micrometers |

All electronic micrometers include protective case

FEATURES AND SPECIFICATIONS

- Automatic OFF after 30 minutes of nonuse
- .250" (6.35mm) spindle diameter
- No-glare black wrinkle finish on frame
- No-glare satin chrome finish on thimble and sleeve
- Ring-type knurled lock nut for quick and sure locking
- English/Metric models feature inch graduations on shell and thimble
- Metric/English (ME) models have mm graduations on shell and thimble
- Instant inch/millimeter conversion
- Measurement HOLD button
- Ability to zero tool at any position
- Ability to retain and return to the true zero reading of the micrometer
- PRESET button to install any reading at any position
- Includes one 3-volt battery for over one year of normal usage



ELECTRONIC MICROMETERS

733 ELECTRONIC MICROMETERS (WITH OUTPUT)

0-24"/0-600MM

- With output to cable or DataSure® Wireless Systems

MICROMETERS

| 733 Electronic Micrometers with Standard Inch Graduations | | | | | |
|---|-------|---------|-------------|------------|-------|
| Cat. No. | EDP | Range | | Resolution | |
| | | in | mm | in | mm |
| 733XFL-1 | 64239 | 0 - 1 | 0 - 25.4 | 0.0001 | 0.001 |
| 733XFL-1 W/SLC | 66905 | | | | |
| 733XFLZ-2 | 64241 | 1 - 2 | 25.4 - 50.8 | 0.0001 | 0.001 |
| 733XFLZ-3 | 64242 | | | | |
| 733XFLZ-4 | 64243 | 3 - 4 | 76 - 101 | 0.0001 | 0.001 |
| 733XFLZ-5 | 64244 | | | | |
| 733XFLZ-6 | 64245 | 4 - 5 | 101 - 127 | 0.0001 | 0.001 |
| 733XFLZ-7 | 64246 | | | | |
| 733XFLZ-8 | 64247 | 5 - 6 | 127 - 152 | 0.0001 | 0.001 |
| 733XFLZ-9 | 64248 | | | | |
| 733XFLZ-10 | 64249 | 6 - 7 | 152 - 178 | 0.0001 | 0.001 |
| 733XFLZ-11 | 64250 | | | | |
| 733XFLZ-12 | 64251 | 7 - 8 | 178 - 203 | 0.0001 | 0.001 |
| 733XFLZ-13 | 64415 | | | | |
| 733XFLZ-14 | 64416 | 8 - 9 | 203 - 228 | 0.0001 | 0.001 |
| 733XFLZ-15 | 64417 | | | | |
| 733XFLZ-16 | 64418 | 9 - 10 | 228 - 254 | 0.0001 | 0.001 |
| 733XFLZ-17 | 64419 | | | | |
| 733XFLZ-18 | 64420 | 10 - 11 | 254 - 279 | 0.0001 | 0.001 |
| 733XFLZ-19 | 64421 | | | | |
| 733XFLZ-20 | 64422 | 11 - 12 | 279 - 305 | 0.0001 | 0.001 |
| 733XFLZ-21 | 64423 | | | | |
| 733XFLZ-22 | 64424 | 12 - 13 | 305 - 330 | 0.0001 | 0.001 |
| 733XFLZ-23 | 64425 | | | | |
| 733XFLZ-24 | 64426 | 13 - 14 | 330 - 355 | 0.0001 | 0.001 |
| | | | | | |
| | | 14 - 15 | 355 - 381 | 0.0001 | 0.001 |
| | | | | | |
| | | 15 - 16 | 381 - 406 | 0.0001 | 0.001 |
| | | | | | |
| | | 16 - 17 | 406 - 432 | 0.0001 | 0.001 |
| | | | | | |
| | | 17 - 18 | 432 - 457 | 0.0001 | 0.001 |
| | | | | | |
| | | 18 - 19 | 457 - 482 | 0.0001 | 0.001 |
| | | | | | |
| | | 19 - 20 | 482 - 508 | 0.0001 | 0.001 |
| | | | | | |
| | | 20 - 21 | 508 - 533 | 0.0001 | 0.001 |
| | | | | | |
| | | 21 - 22 | 533 - 559 | 0.0001 | 0.001 |
| | | | | | |
| | | 22 - 23 | 559 - 584 | 0.0001 | 0.001 |
| | | | | | |
| | | 23 - 24 | 584 - 609 | 0.0001 | 0.001 |
| | | | | | |

All except 1" size furnished with standards.

| 733 Electronic Micrometers with Standard Millimeter Graduations | | | | | |
|---|-------|-----------|-----------------|------------|--------|
| Cat. No. | EDP | Range | | Resolution | |
| | | mm | in | mm | in |
| 733MEXFL-25 | 65440 | 0 - 25 | 0 - .984 | 0.001 | 0.0001 |
| 733MEXFLZ-50 | 65441 | | | | |
| 733MEXFLZ-75 | 66079 | 25 - 50 | .984 - 1.968 | 0.001 | 0.0001 |
| 733MEXFLZ-100 | 66080 | | | | |
| 733MEXFLZ-125 | 66081 | 50 - 75 | 1.968 - 2.950 | 0.001 | 0.0001 |
| 733MEXFLZ-150 | 66082 | | | | |
| 733MEXFLZ-175 | 66083 | 75 - 100 | 2.950 - 3.930 | 0.001 | 0.0001 |
| 733MEXFLZ-200 | 66084 | | | | |
| 733MEXFLZ-225 | 66085 | 100 - 125 | 3.930 - 4.920 | 0.001 | 0.0001 |
| 733MEXFLZ-250 | 66086 | | | | |
| 733MEXFLZ-275 | 66087 | 125 - 150 | 4.920 - 5.900 | 0.001 | 0.0001 |
| 733MEXFLZ-300 | 66088 | | | | |
| 733MEXFLZ-325 | 66089 | 150 - 175 | 5.900 - 6.890 | 0.001 | 0.0001 |
| 733MEXFLZ-350 | 66090 | | | | |
| 733MEXFLZ-375 | 66091 | 175 - 200 | 6.890 - 7.870 | 0.001 | 0.0001 |
| 733MEXFLZ-400 | 66092 | | | | |
| 733MEXFLZ-425 | 66093 | 200 - 225 | 7.870 - 8.850 | 0.001 | 0.0001 |
| 733MEXFLZ-450 | 66094 | | | | |
| 733MEXFLZ-475 | 66095 | 225 - 250 | 8.850 - 9.840 | 0.001 | 0.0001 |
| 733MEXFLZ-500 | 66096 | | | | |
| 733MEXFLZ-525 | 66097 | 250 - 275 | 9.840 - 10.820 | 0.001 | 0.0001 |
| 733MEXFLZ-550 | 66098 | | | | |
| 733MEXFLZ-575 | 66099 | 275 - 300 | 10.820 - 11.810 | 0.001 | 0.0001 |
| 733MEXFLZ-600 | 66100 | | | | |
| | | 300 - 325 | 11.810 - 12.790 | 0.001 | 0.0001 |
| | | | | | |
| | | 325 - 350 | 12.790 - 13.770 | 0.001 | 0.0001 |
| | | | | | |
| | | 350 - 375 | 13.770 - 14.760 | 0.001 | 0.0001 |
| | | | | | |
| | | 375 - 400 | 14.760 - 15.740 | 0.001 | 0.0001 |
| | | | | | |
| | | 400 - 425 | 15.740 - 16.730 | 0.001 | 0.0001 |
| | | | | | |
| | | 425 - 450 | 16.730 - 17.710 | 0.001 | 0.0001 |
| | | | | | |
| | | 450 - 475 | 17.710 - 18.700 | 0.001 | 0.0001 |
| | | | | | |
| | | 475 - 500 | 18.700 - 19.680 | 0.001 | 0.0001 |
| | | | | | |
| | | 500 - 525 | 19.680 - 20.660 | 0.001 | 0.0001 |
| | | | | | |
| | | 525 - 550 | 20.660 - 21.650 | 0.001 | 0.0001 |
| | | | | | |
| | | 550 - 575 | 21.650 - 22.630 | 0.001 | 0.0001 |
| | | | | | |
| | | 575 - 600 | 22.630 - 23.620 | 0.001 | 0.0001 |
| | | | | | |

All except 1" and 0-25mm sizes furnished with standards.



733 Micrometer with DataSure End Node

733 Electronic Micrometer Accessories

| Cat. No. | EDP | Description |
|----------|-------|---|
| 957 | 66565 | Protective case for 733 Micrometers |
| 949 | 63874 | Deluxe padded case for 25mm 733 Micrometers |
| 733SCKB | 69888 | USB cable to PC (In focused window) |
| 733SCU | 69898 | USB cable to computer running SPC Data Collection Software |
| 733SCM | 69893 | SmartCable connection to Multiplexer (7612, 7613 or RMS 2704) |
| PT61963 | 66636 | Computer Interface Cable Complete to PC (RS232C) |
| PT61120 | 65446 | One 3-volt battery CR2450 for 733 Micrometers |

733 Micrometer Specifications

| Description | in | mm |
|-------------------------------|--------|--------|
| Resolution through 4" (100mm) | .00005 | 0.001 |
| Resolution over 4" (100mm) | .0001 | 0.001 |
| Accuracy* | ±.0001 | ±0.002 |

* Accuracies above 1" (25mm) are as good as setting to a gage because the mechanical and electronic components are the same on all ranges.
All electronic micrometers include protective case.



DIGITAL MICROMETERS

216 DIGITAL MICROMETERS

0-12"/0-300MM

This is the 216 Mechanical Digital Micrometer – simple to use even by the inexperienced. The anvil and spindle are sized at .250" (6.35mm).

READABILITY FEATURES

- Clear, easily read numbers reduce errors
- No-glare black finish on the frame
- Starrett no-glare satin chrome finish on thimble and sleeve
- .001" or .01mm is read directly from the counter
- .0001" or .001mm is read from the vernier scale on the micrometer sleeve

EASE-OF-HANDLING FEATURES

- Balanced frame design for comfortable and accurate measuring
- Ring-type knurled lock nut for quick and sure locking
- A choice of smooth friction thimble for uniform pressure on the 1-4" sizes or the combination ratchet and speeder for uniform pressure and quicker adjustment on all sizes
- Gracefully designed tapered frame for use in narrow slots and tight places

ACCURACY AND LONG-LIFE FEATURES

- Extremely hard and stable one-piece spindle (the heart of our accuracy)

S216 DIGITAL MICROMETER SET

0-3"

Set of three digital micrometers – furnished with ratchet stop, lock nut, and standards, in case.

- Set consists of three micrometers: 0-1", 1-2", and 2-3"
- .001" is read directly from the counter
- .0001" is read from the sleeve
- Clear, easily read numbers
- Balanced frame design and extremely hard and stable one-piece spindle



| 216 Digital Micrometers | | | | | | | | | |
|---------------------------|-------|-------------------------------|-------|----------|-------|--------|-----------|-----------------|--|
| Ratchet Stop and Lock Nut | | Friction Thimble and Lock Nut | | Plain | | Grads. | Range | Measuring Faces | |
| Cat. No. | EDP | Cat. No. | EDP | Cat. No. | EDP | | | | |
| 216RL-1 | 55953 | 216FL-1 | 55954 | 216P-1 | 55952 | .001 | 0-1" | Steel | |
| 216XRL-1 | 55955 | 216XFL-1 | 55956 | | | | | Carbide | |
| 216RL-2 | 56153 | 216FL-2 | 56257 | | | | 1-2" | | |
| 216RL-3 | 56205 | 216FL-3 | 56206 | | | | 2-3" | | |
| 216RL-4 | 56208 | 216FL-4 | 56209 | | | .001" | 3-4" | Steel | |
| 216RL-5 | 63470 | | | | | | 4-5" | | |
| 216RL-6 | 63471 | | | | | | 5-6" | | |
| 216XRL-7 | 63628 | | | | | | 6-7" | | |
| 216XRL-8 | 63629 | | | | | | 7-8" | | |
| 216XRL-9 | 63630 | | | | | .001" | 8-9" | Carbide | |
| 216XRL-10 | 63631 | | | | | | 9-10" | | |
| 216XRL-11 | 63632 | | | | | | 10-11" | | |
| 216XRL-12 | 63633 | | | | | | 11-12" | | |
| T216XRL-1 | 55959 | T216XFL-1 | 55960 | | | | 0-1" | | |
| T216XRL-1 W/SLC | 66904 | T216XFL-1 W/SLC | 66903 | | | | | | |
| T216XRL-2 | 56156 | T216XFL-2 | 56157 | | | | 1-2" | | |
| T216XRL-3 | 63491 | T216XFL-3 | 63634 | | | | 2-3" | | |
| T216XRL-4 | 63492 | | 63635 | | | | 3-4" | | |
| T216XRL-5 | 63493 | | | | | .0001" | 4-5" | Carbide | |
| T216XRL-6 | 63494 | | | | | | 5-6" | | |
| T216XRL-7 | 63495 | | | | | | 6-7" | | |
| T216XRL-8 | 63496 | | | | | | 7-8" | | |
| T216XRL-9 | 63497 | | | | | | 8-9" | | |
| T216XRL-10 | 63498 | | | | | | 9-10" | | |
| T216XRL-11 | 63499 | | | | | | 10-11" | | |
| T216XRL-12 | 63500 | | | | | | 11-12" | | |
| 216MXRL-25 | 55983 | 216MXFL-25 | 55984 | | | | 0-25mm | | |
| 216MXRL-50 | 65602 | | | | | | 25-50mm | | |
| 216MXRL-75 | 65603 | | | | | | 50-75mm | | |
| 216MXRL-100 | 65604 | | | | | | 75-100mm | | |
| 216MXRL-125 | 64351 | | | | | .01mm | 100-125mm | Carbide | |
| 216MXRL-150 | 64352 | | | | | | 125-150mm | | |
| 216MXRL-175 | 64353 | | | | | | 150-175mm | | |
| 216MXRL-200 | 64354 | | | | | | 175-200mm | | |
| 216MXRL-225 | 64355 | | | | | | 200-225mm | | |
| 216MXRL-250 | 64356 | | | | | | 225-250mm | | |
| 216MXRL-275 | 64357 | | | | | | 250-275mm | | |
| 216MXRL-300 | 64358 | | | | | | 275-300mm | | |
| V216MXRL-25 | 56037 | V216MXFL-25 | 56036 | | | | 0-25mm | | |
| V216MXRL-50 | 64348 | | | | | .001mm | 25-50mm | Carbide | |
| V216MXRL-75 | 64349 | | | | | | 50-75mm | | |
| V216MXRL-100 | 64350 | | | | | | 75-100mm | | |

| S216 Digital Micrometer Set | |
|-----------------------------|-------|
| Cat. No. | EDP |
| ST216AXRLZ | 66526 |

Cases Only for 216 and 216M Digital Micrometers

| Cat. No. | EDP | Fits Micrometer Range | |
|----------|-------|-----------------------|---------|
| | | in | mm |
| 942 | 55961 | 0-1 | 0-25 |
| 216ZZ-2 | 56171 | 1-2 | 25-50 |
| 922 | 55222 | 2-3 | 50-75 |
| 952 | 55223 | 3-4 | 75-100 |
| 953 | 55224 | 4-5 | 100-125 |
| 954 | 55225 | 5-6 | 125-150 |
| 930 | 55276 | 6-7 | 150-175 |
| 931 | 55277 | 7-8 | 175-200 |
| 932 | 55278 | 8-9 | 200-225 |
| 933 | 55279 | 9-10 | 225-250 |
| 934 | 55280 | 10-11 | 250-275 |
| 935 | 55281 | 11-12 | 275-300 |



OUTSIDE MICROMETERS



230 OUTSIDE MICROMETERS

0-1"/0-25MM

This is the jewel of precision micrometers used by skilled workmen worldwide. The spindle and anvil are sized at .235" (6mm) to reach places most micrometers cannot reach.

FEATURES AND SPECIFICATIONS

- Same as our 232 Outside Micrometers plus quick-reading figures – every thousandth numbered on inch tools
- Same as our 232 Outside Micrometers with a choice of smooth friction thimble for uniform pressure or the combination ratchet and speeder for uniform pressure and quicker adjustment

230 and 230M Outside Micrometers (0-1" Range)

| Cat. No. | EDP | Graduation |
|---------------|-------|------------|
| 230P | 50932 | .001" |
| 230RL | 50935 | |
| 230FL | 50938 | |
| T230RL | 50943 | .0001" |
| T230XRL | 50944 | |
| T230XRL W/SLC | 64401 | |
| T230FL | 50946 | |
| T230XFL | 50947 | |
| T230XFL W/SLC | 66916 | 0.001mm |
| V230MXRL | 56017 | |
| V230MXFL | 56016 | |

Deluxe Padded Case for 230 and 230M Outside Micrometers

| Cat. No. | EDP | Description |
|----------|-------|--------------------------------|
| 910 | 55397 | Case for 1" (25mm) Micrometers |

Case not included.

232 OUTSIDE MICROMETERS

0-1/2"/0-12.5MM

These micrometers are the 1/2" (13mm) companions of the top-of-the-line 230 Micrometers. The spindle and anvil are sized at .200" (5mm).

FEATURES AND SPECIFICATIONS

- Starrett satin chrome finish – no glare – resists rust
- Advanced sleeve design with staggered lines and distinct figures for precise and easy readability
- Convenient decimal equivalents on inch tools
- Rigid one-piece frame of drop forged steel
- Extremely hard and stable one-piece spindle (the heart of our accuracy)
- Quick and easy adjustment
- Balanced frame and thimble design ensure easy handling and better readability
- Ring-type knurled lock nut for quick and sure locking
- Combination ratchet and speeder for uniform pressure and quicker adjustment
- Gracefully designed tapered frame for use in narrow slots and tight places

232 and 232M Outside Micrometers

| Cat. No. | EDP | Range | Graduation |
|----------|-------|--------|------------|
| 232RL | 50953 | 0-1/2" | .001" |
| T232RL | 50955 | | .0001" |
| T232XRL | 50968 | | |
| 232MRL | 50954 | 0-13mm | 0.01mm |
| V232MXRL | 64231 | | 0.002mm |

Attractive, Protective Case for 232 and 232M Outside Micrometers

| Cat. No. | EDP | Description |
|----------|-------|----------------------------------|
| 921 | 55213 | Case for 1/2" (13mm) Micrometers |

Case not included.



OUTSIDE MICROMETERS

2 OUTSIDE MICROMETERS

1-2"/25-50MM

These micrometers are the 2" (50mm) companions of the top-of-the-line 230 Micrometer.

The spindle and anvil are sized at .235" (6mm) to reach places other micrometers cannot.

READABILITY FEATURES

- Starrett satin chrome finish – no glare – resists rust
- Advanced sleeve design with staggered and distinct figures for precise and easy readability
- Convenient decimal equivalents on inch tools

EASE-OF-HANDLING FEATURES

- Balanced frame and thimble design ensure easy handling and better readability
- Ring-type knurled lock nut for quick and sure locking
- A choice of smooth friction thimble for uniform pressure or the combination ratchet and speeder for uniform pressure and quicker adjustment
- Gracefully designed tapered frame for use in narrow slots and tight places

ACCURACY AND LONG-LIFE FEATURES

- Rigid one-piece frame of drop forged steel
- Extremely hard and stable one-piece spindle (the heart of our accuracy)
- Appropriate 1" or 25mm gage block standard furnished with micrometers

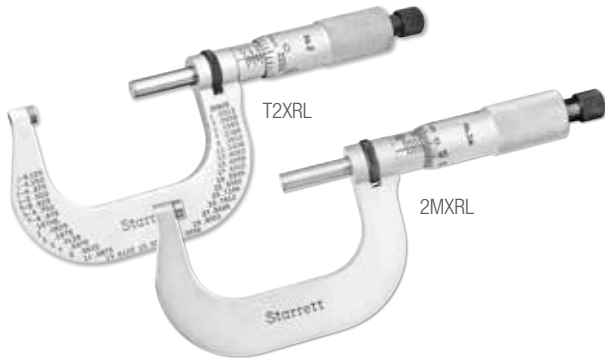

2A OUTSIDE MICROMETERS WITH ATTACHMENT

0-2"/0-50MM

These micrometers are versions of the 2 and 2M that include an attachment to handle measurements from 0-1" or 0-25mm, thereby extending the total range from 0-2" or 50mm.

Easily and quickly attached to the anvil of the micrometer, it is only necessary to tighten a locking screw to make the conversion. The anvil extension is hardened, ground and lapped. No-glare satin chrome finish.

2 and 2M Outside Micrometers

| Cat. No. | EDP | Range | Graduation |
|----------|-------|---------|------------|
| T2XRL | 50024 | 1-2" | .0001" |
| T2XFL | 50025 | | |
| 2MXRL | 50026 | 25-50mm | 0.01mm |
| V2MXRL | 63793 | | |

2A and 2MA Outside Micrometer

| Cat. No. | EDP | Range | Graduation |
|----------|-------|--------|------------|
| 2ARL | 50027 | 0-2" | .001" |
| 2MARL | 50029 | 0-50mm | 0.01mm |

Deluxe Padded Case for 2, 2A, 2M and 2MA Outside Micrometers

| Cat. No. | EDP | Description |
|----------|-------|----------------------------------|
| 912 | 55399 | Case for 2" and 50mm Micrometers |

Micrometers furnished in a protective case.

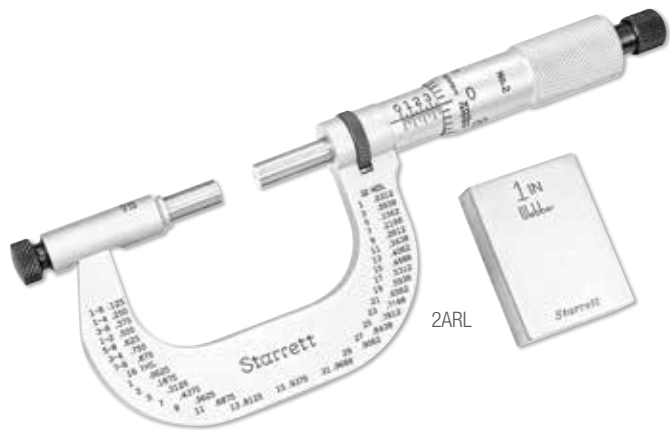

STAINLESS STEEL MICROMETERS

1230 STAINLESS STEEL MICROMETERS

0-1"/0-25MM

1212 STAINLESS STEEL MICROMETERS

1-2"/25-50MM

This micrometer is made from stainless steel for use under adverse atmospheric and operating conditions.

1230 and 1230M Stainless Steel Micrometers

| Cat. No. | EDP | Range | Graduation |
|-----------|-------|--------|------------|
| 1230XRL | 53196 | 0-1" | .001" |
| T1230XRL | 53197 | | .0001" |
| V1230MXRL | 64263 | 0-25mm | 0.001mm |

1212 and 1212M Stainless Steel Micrometers

| Cat. No. | EDP | Range | Graduation |
|-----------|-------|---------|------------|
| 1212XRL | 53178 | 1-2" | .001" |
| T1212XRL | 53179 | | .0001" |
| V1212MXRL | 64264 | 25-50mm | 0.001mm |

Deluxe Padded Cases for 1212 and 1212M Stainless Steel Micrometers

| Cat. No. | EDP | Description |
|----------|-------|--------------------------------|
| 910 | 55397 | Case for 1" (25mm) Micrometers |
| 912 | 55399 | Case for 2" (50mm) Micrometers |

1" and 25mm Models sent in fitted case. 2" and 50mm Models packed one in a box without case.

READABILITY FEATURES

- Satin finish stainless steel – no glare – rust and stain resistant
- Advanced sleeve design with staggered lines and distinct figures for precise and easy readability
- Convenient decimal equivalents on inch tools

EASE-OF-HANDLING FEATURES

- Balanced frame and thimble design ensure easy handling and better readability
- Ring-type knurled lock nut for quick and sure locking
- The combination ratchet and speeder for uniform pressure and quicker adjustment
- Gracefully designed tapered frame for use in narrow slots and tight places

ACCURACY AND LONG-LIFE FEATURES

- Rigid one-piece frame of drop forged steel
- Extremely hard and stable one-piece spindle (the heart of our accuracy)
- Quick and easy adjustment
- Gage block standard supplied for 1-2" micrometer

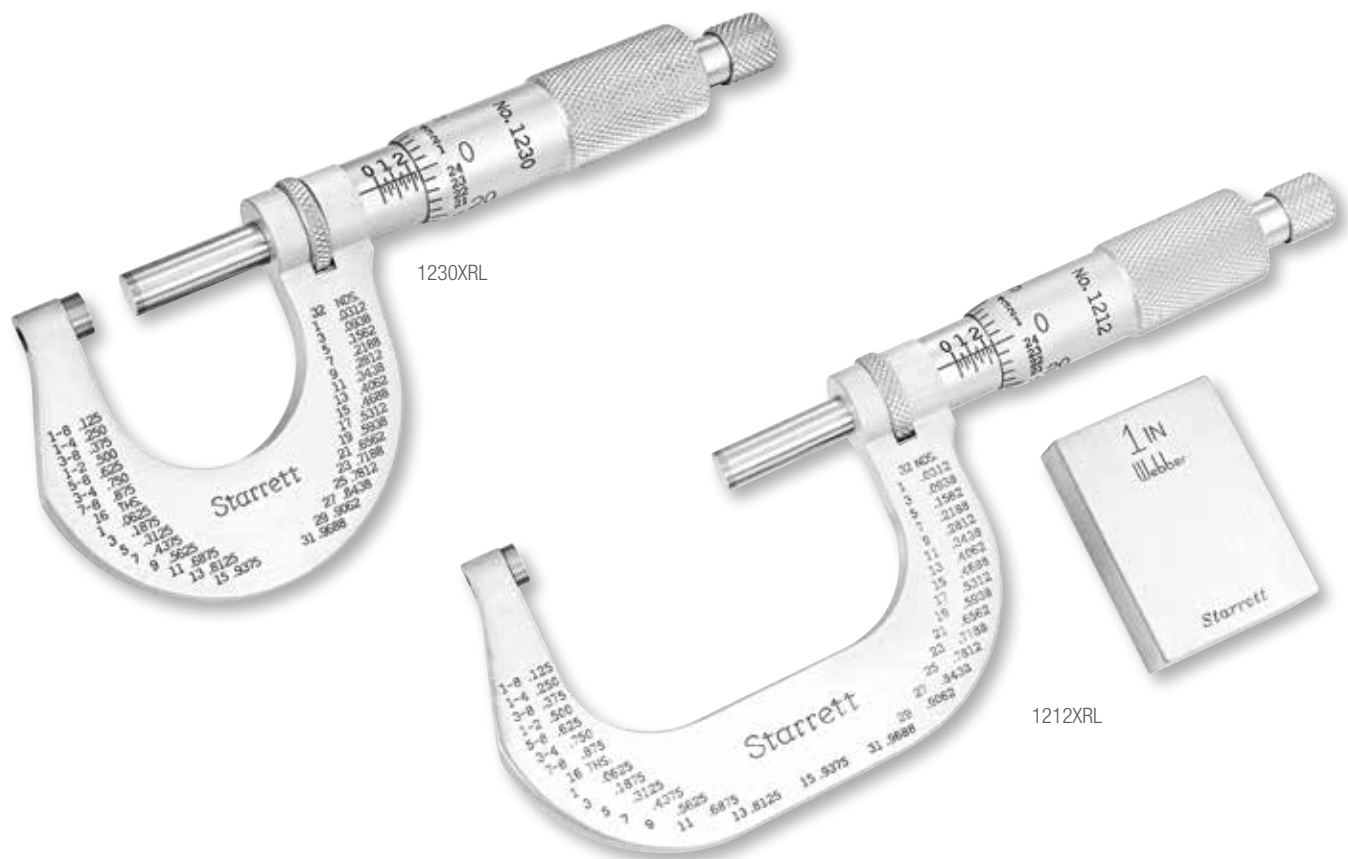

OUTSIDE MICROMETERS

NEW!

T444.1 OUTSIDE MICROMETER

The T444.1 Outside Micrometers have a heat-insulator on the frame to help reduce temperature-related expansion or contraction. The spindle and anvil have flat measuring faces and are carbide-tipped for wear resistance. A spindle lock helps provide secure locking of the measurement.

FEATURES

- No-glare satin chrome finish which resists rust
- Advanced sleeve design with staggered lines and distinct figures for precise and easy readability
- Balanced frame and thimble design to ensure easy handling and better readability
- Insulated frame for prevention of temperature related expansion and contraction
- Provides quick and easy adjustment
- Reading in ten-thousandths of an inch (.0001") with a vernier scale on the sleeve

MICROMETERS

| Cat. No. | EDP | Graduation | Range |
|---------------|-------|------------|-----------|
| T444.1XRL-1 | 52083 | .0001" | 0-1" |
| T444.1XRL-2 | 52084 | .0001" | 1-2" |
| T444.1XRL-3 | 52085 | .0001" | 2-3" |
| T444.1XRL-4 | 52086 | .0001" | 3-4" |
| T444.1XRL-5 | 52087 | .0001" | 4-5" |
| T444.1XRL-6 | 52088 | .0001" | 5-6" |
| 444.1MXRL-25 | 51072 | .01mm | 0-25mm |
| 444.1MXRL-50 | 51073 | .01mm | 25-50mm |
| 444.1MXRL-75 | 51085 | .01mm | 50-75mm |
| 444.1MXRL-100 | 51088 | .01mm | 75-100mm |
| 444.1MXRL-125 | 51091 | .01mm | 100-125mm |
| 444.1MXRL-150 | 91094 | .01mm | 125-150mm |

| Sets | | | | |
|--------------|-------|------------|---------|---------------------------------------|
| Cat. No. | EDP | Graduation | Range | Description |
| ST444.1BXRLZ | 72531 | .0001" | 0-4" | Set of four micrometers in metal case |
| ST444.1CXRLZ | 72532 | .0001" | 0-6" | Set of four micrometers in metal case |
| S444.1MBXRLZ | 21089 | .01mm | 0-100mm | Set of four micrometers in metal case |
| S444.1MCXRLZ | 21090 | .01mm | 0-150mm | Set of four micrometers in metal case |

All micrometers and sets furnished with a protective case.



T444.1XRL-4

T444.1XRL-1



MICROMETERS

231, 231M MICROMETERS WITH INSULATED FRAMES

0-1"/0-25MM

This is a slightly heavier micrometer with thermal insulators mounted on the frame front and rear. This spindle and anvil are sized at .250" (6.35mm).

READABILITY FEATURES

- Starrett satin chrome finish – no glare – resists rust
- Advanced sleeve design with staggered lines and distinct figures for precise and easy readability
- Quick-reading figures – every thousandth numbered on inch tools

EASE-OF-HANDLING FEATURES

- Balanced frame and thimble design ensure easy handling and better readability
- Ring-type knurled lock nut for quick and sure locking
- A combination ratchet and speeder for uniform pressure and quicker adjustment on all sizes
- Gracefully designed tapered frame for use in narrow slots and tight places

ACCURACY AND LONG-LIFE FEATURES

- Rigid one-piece frame of drop forged steel
- Extremely hard and stable one-piece spindle (the heart of our accuracy)
- Quick and easy adjustment

221 HI-PRECISION MICROMETER

0-1"

- Permits direct readings in ten-thousandths of an inch (.0001") without a vernier, plus automatic control of spindle pressure
- Black graduated inner thimble and sleeve reading in thousandths and red graduated outer thimble and sleeve with large, widely spaced graduations which give direct readings in ten-thousandths

READABILITY FEATURES

- Exclusive constant pressure mechanism eliminates "feel" and ensures constant spindle pressure for all readings
- Starrett satin chrome finish – no glare – resists rust
- Advanced sleeve design with staggered lines and distinct figures for precise and easy readability
- Convenient decimal equivalents on inch tools

EASE-OF-HANDLING FEATURES

- Balanced frame and thimble design for easy handling and better readability
- Ring-type knurled lock nut for quick and sure locking
- Gracefully designed tapered frame for use in narrow slots and tight places

ACCURACY AND LONG-LIFE FEATURES

- Rigid one-piece frame of drop forged steel
- Extremely hard and stable one-piece spindle (the heart of our accuracy)
- Quick and easy adjustment

| 231 and 231M Micrometers (0-1" Range) | | | |
|---|-------|--------------------------------|------------|
| Cat. No. | EDP | Range | Graduation |
| T231XRL | 63967 | 0-1" | .0001" |
| V231MXRL | 63969 | 0-25mm | 0.001mm |
| Deluxe Padded Case for 231 and 231M Micrometers | | | |
| Cat. No. | EDP | Description | |
| 942 | 55961 | Case for 1" (25mm) Micrometers | |

| 221 Hi-Precision Micrometer (0-1" Range) | | |
|--|-------|--------------------------------|
| Cat. No. | EDP | Graduation |
| T221XL | 50754 | .0001" |
| Deluxe Padded Case for 221 Hi-Precision Micrometer | | |
| Cat. No. | EDP | Description |
| 910 | 55397 | Case for 1" (25mm) Micrometers |



V231MXRL

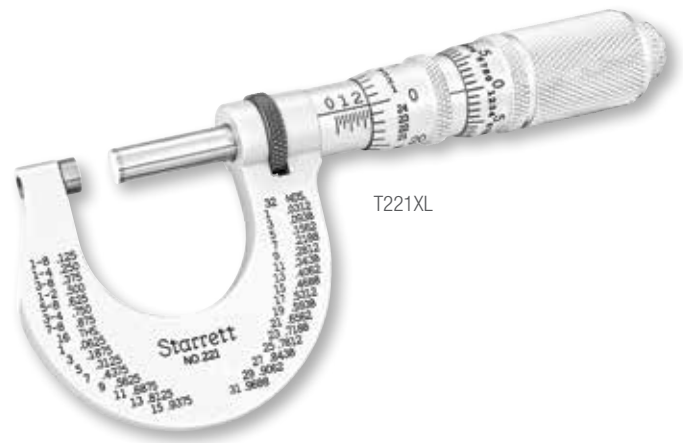

T221XL



ST226AXRLZ



T226XRL-1

OUTSIDE MICROMETERS

226 OUTSIDE MICROMETERS

1-6"/25-150MM

- Rugged construction and extremely attractive design
- For craftsmen who want a precision micrometer with a distinctive Starrett design and finish
- Strong ribbed frame with smooth black enamel finish and polished steel ribs and hub

226 Outside Micrometers (.001" Graduation)

| Ratchet Stop and Lock Nut | | Standard (extra) | | Range |
|---------------------------|-------|------------------|-------|-------|
| Cat. No. | EDP | Cat. No. | EDP | |
| 226RL-1 | 12209 | | | 0-1" |
| 226RL-2 | 50820 | 234B-1 | 51017 | 1-2" |
| 226RL-3 | 50825 | 234B-2 | 51019 | 2-3" |
| 226RL-4 | 50830 | 234B-3 | 51021 | 3-4" |
| 226RL-5 | 50835 | 234B-4 | 51023 | 4-5" |
| 226RL-6 | 50840 | 234B-5 | 51025 | 5-6" |

226 Outside Micrometers, Carbide Faces (.0001" Graduation)

| | | | | |
|-----------|-------|--------|-------|------|
| T226XRL-1 | 12211 | | | 0-1" |
| T226XRL-2 | 50903 | 234B-1 | 51017 | 1-2" |
| T226XRL-3 | 50904 | 234B-2 | 51019 | 2-3" |
| T226XRL-4 | 50905 | 234B-3 | 51021 | 3-4" |
| T226XRL-5 | 50906 | 234B-4 | 51023 | 4-5" |
| T226XRL-6 | 50907 | 234B-5 | 51025 | 5-6" |

226M Outside Micrometers, Carbide Faces (0.001mm Graduation)

| | | | | |
|--------------|-------|-----------|-------|-----------|
| V226MXRL-25 | 12212 | | | 0-25mm |
| V226MXRL-50 | 64265 | 234MB-25 | 51018 | 25-50mm |
| V226MXRL-75 | 64266 | 234MB-50 | 51020 | 50-75mm |
| V226MXRL-100 | 64267 | 234MB-75 | 51022 | 75-100mm |
| V226MXRL-125 | 64268 | 234MB-100 | 51024 | 100-125mm |
| V226MXRL-150 | 64269 | 234MB-125 | 51026 | 125-150mm |

Micrometer Cases for 226 and 226M Outside Micrometers

| Cat. No. | EDP | Description |
|----------|-------|----------------|
| 910 | 55397 | for 1" (25mm) |
| 913 | 55400 | for 2" (50mm) |
| 922 | 55222 | for 3" (75mm) |
| 952 | 55223 | for 4" (100mm) |
| 953 | 55224 | for 5" (125mm) |
| 954 | 55225 | for 6" (150mm) |

Furnished in an attractive protective case.

S226 MICROMETER SETS WITH STANDARDS IN CASE

0-6"/0-150MM

These sets are recommended for mechanics, automotive service and machine shops, toolrooms, inspection departments, and wherever gaging involves a wide range of measurements.

READABILITY FEATURES

- Starrett satin chrome finish – no glare – resists rust
- Advanced sleeve design with staggered lines and distinct figures for precise and easy readability
- Quick-reading figures – every thousandth numbered on inch tools

EASE-OF-HANDLING FEATURES

- Balanced frame and thimble design ensure easy handling and better readability
- Ring-type knurled lock nut for quick and sure locking

ACCURACY AND LONG-LIFE FEATURES

- Rugged frame ribbed for extra strength
- Extremely hard and stable one-piece spindle (the heart of our accuracy)
- Quick and easy adjustment

S226 and S226M Micrometer Sets

| Cat. No. | EDP | Range | Graduation | Set Description |
|-------------|-------|---------|------------|--|
| S226ARLZ | 50854 | 0-3" | .001" | Includes 1", 2" and 3" Micrometers, Two Standards, Adjusting Wrench |
| ST226AXRLZ | 56448 | | .0001" | |
| S226BRLZ | 50862 | | .001" | Includes 1", 2", 3", 4", 5" and 6" Micrometers, Set of Five Standards, Adjusting Wrench |
| ST226BXRLZ | 56798 | 0-6" | .0001" | |
| SV226MAXRLZ | 65237 | 0-75mm | 0.001mm | Includes 25mm, 50mm and 75mm Micrometers, Two Standards, Adjusting Wrench |
| SV226MBXRLZ | 65238 | 0-150mm | 0.001mm | Includes 25mm, 50mm, 75mm, 100mm, 125mm and 150mm Micrometers, Set of Five Standards, Adjusting Wrench |

Cases Only for S226 and S226M Micrometer Sets

| Cat. No. | EDP | Description |
|----------|-------|---|
| 955 | 55226 | Case for 0-3" and 0-75mm Micrometer Sets |
| 956 | 55227 | Case for 0-6" and 0-150mm Micrometer Sets |



OUTSIDE MICROMETERS

436.1 OUTSIDE MICROMETERS

0-6"

These are the most popular precision micrometers used by skilled workmen worldwide. They are accurate, rugged, and easy to use.

The 0-6" and 0-150mm sizes have rugged spindles and anvils at .250" (6.35mm) diameter.

| 436.1 Outside Micrometers (0-1" Range) | | 436.1 Outside Micrometers (1-2" Range) | | |
|--|-------|--|-------|------------|
| Cat. No. | EDP | Cat. No. | EDP | Graduation |
| 436.1P-1 | 67990 | 436.1P-2 | 68001 | .001" |
| 436.1XP-1 | 67991 | | | |
| 436.1RL-1 | 67993 | 436.1RL-2 | 68002 | |
| 436.1XRL-1 | 67994 | 436.1XRL-2 | 68003 | |
| 436.1XRL-1 W/SLC | 67995 | | | |
| 436.1FL-1 | 67996 | 436.1FL-2 | 68004 | |
| T436.1XP-1 | 67992 | | | |
| T436.1XRL-1 | 67997 | T436.1XRL-2 | 68005 | |
| T436.1XRL-1 W/SLC | 67998 | T436.1XRL-2 W/SLC | 68006 | |
| T436.1XFL-1 | 67999 | T436.1XFL-2 | 68007 | |
| T436.1XFL-1 W/SLC | 68000 | T436.1XFL-2 W/SLC | 68008 | |
| | | | | .0001" |
| | | | | |
| | | | | |
| | | | | |
| | | | | |
| | | | | |
| | | | | |
| | | | | |
| | | | | |
| | | | | |
| | | | | .001" |
| | | | | |
| | | | | |
| | | | | |
| | | | | |
| | | | | |
| | | | | |
| | | | | |
| | | | | |
| | | | | |
| | | | | .0001" |
| | | | | |
| | | | | |
| | | | | |
| | | | | |
| | | | | |
| | | | | |
| | | | | |
| | | | | |
| | | | | |
| | | | | .001" |
| | | | | |
| | | | | |
| | | | | |
| | | | | |
| | | | | |
| | | | | |
| | | | | |
| | | | | |
| | | | | |
| | | | | .0001" |
| | | | | |
| | | | | |
| | | | | |
| | | | | |
| | | | | |
| | | | | |
| | | | | |
| | | | | |
| | | | | |

Sent in fitted plastic case.

FEATURES AND SPECIFICATIONS

- Starrett satin chrome finish – no glare – resists rust
- Advanced sleeve design with staggered lines and distinct figures for precise and easy readability
- Balanced frame and thimble design ensure easy handling
- Ring-type knurled lock nut for quick and sure locking
- Smooth friction thimble for uniform pressure, the combination ratchet and speeder for uniform pressure and quicker adjustment, or a plain micrometer that depends on your own "feel"
- Gracefully designed tapered frame for use in narrow slots and tight places
- Rigid steel frame ribbed for extra strength on sizes through 6" (150mm)
- Extremely hard and stable one-piece spindle (the heart of our accuracy)
- Quick and easy adjustment



T436.1XRL-2

436.1P-1

See following page for listing of Cases and Standards

OUTSIDE MICROMETERS

436.1 OUTSIDE MICROMETERS

6-24" (0-600MM)

Same balanced design as the smaller sizes but proportioned to these larger sizes with .300" (7.6mm) anvil and spindle diameters for ease of use on larger work.

All the same features as the 0-6" and 0-150mm ranges 436.1 Micrometers, except:

- Larger sizes are furnished with combination ratchet and speeder for uniform pressure and quicker adjustment
- Rigid and stable special cast iron frame with perforations for lightness and ribbed for strength and stability

| 436 Outside Micrometers | | | |
|-------------------------|-------|--------|------------|
| Cat. No. | EDP | Range | Graduation |
| 436.1RL-7 | 72710 | 6-7" | .001" |
| 436.1XRL-7 | 72716 | | |
| T436.1XRL-7 | 72734 | | |
| 436.1RL-8 | 72711 | 7-8" | .001" |
| 436.1XRL-8 | 72717 | | |
| T436.1XRL-8 | 72735 | | |
| 436.1RL-9 | 72712 | 8-9" | .001" |
| 436.1XRL-9 | 72718 | | |
| T436.1XRL-9 | 72736 | | |
| 436.1RL-10 | 72713 | 9-10" | .001" |
| 436.1XRL-10 | 72719 | | |
| T436.1XRL-10 | 72737 | | |
| 436.1RL-11 | 72714 | 10-11" | .001" |
| 436.1XRL-11 | 72720 | | |
| T436.1XRL-11 | 72738 | | |
| 436.1RL-12 | 72715 | 11-12" | .001" |
| 436.1XRL-12 | 72721 | | |
| T436.1XRL-12 | 72739 | | |
| 436.1XRLZ-13 | 72722 | 12-13" | .001" |
| 436.1XRLZ-14 | 72723 | 13-14" | |
| 436.1XRLZ-15 | 72724 | 14-15" | |
| 436.1XRLZ-16 | 72725 | 15-16" | |
| 436.1XRLZ-17 | 72726 | 16-17" | |
| 436.1XRLZ-18 | 72727 | 17-18" | |
| 436.1XRLZ-19 | 72728 | 18-19" | |
| 436.1XRLZ-20 | 72729 | 19-20" | |
| 436.1XRLZ-21 | 72730 | 20-21" | |
| 436.1XRLZ-22 | 72731 | 21-22" | |
| 436.1XRLZ-23 | 72732 | 22-23" | |
| 436.1XRLZ-24 | 72733 | 23-24" | |

7-12" models sent without case, packed one each to a box.
13-24" models are furnished in a case at no extra charge.

| 436 Outside Micrometers | | | |
|-------------------------|-------|-----------|------------|
| Cat. No. | EDP | Range | Graduation |
| 436.1MP-25 | 68047 | 0-25mm | 0.01mm |
| 436.1MRL-25 | 68048 | | |
| 436.1MXFL-25 | 68050 | | |
| V436.1MXRL-25 | 68051 | | |
| 436.1MXRL-25 | 68049 | 0-25mm | 0.001mm |
| 436.1MRL-50 | 68052 | 25-50mm | 0.01mm |
| 436.1MXRL-50 | 68053 | | |
| V436.1MXRL-50 | 68054 | 25-50mm | 0.001mm |
| 436.1MRL-75 | 68055 | 50-75mm | 0.01mm |
| 436.1MXRL-75 | 68056 | | |
| V436.1MXRL-75 | 68057 | 50-75mm | 0.001mm |
| 436.1MRL-100 | 68058 | 75-100mm | 0.01mm |
| 436.1MXRL-100 | 68059 | | |
| V436.1MXRL-100 | 68060 | 75-100mm | 0.001mm |
| 436.1MRL-125 | 68061 | 100-125mm | 0.01mm |
| 436.1MXRL-125 | 68062 | | |
| V436.1MXRL-125 | 68063 | 100-125mm | 0.001mm |
| 436.1MRL-150 | 68064 | 125-150mm | 0.01mm |
| 436.1MXRL-150 | 68065 | | |
| V436.1MXRL-150 | 68066 | 125-150mm | 0.001mm |
| 436.1MXRL-175 | 72740 | 150-175mm | 0.01mm |
| 436.1MXRL-200 | 72741 | 175-200mm | |
| 436.1MXRL-225 | 72742 | 200-225mm | |
| 436.1MXRL-250 | 72743 | 225-250mm | |
| 436.1MXRL-275 | 72744 | 250-275mm | |
| 436.1MXRL-300 | 72745 | 275-300mm | |
| 436.1MXRLZ-325 | 72746 | 300-325mm | |
| 436.1MXRLZ-350 | 72747 | 325-350mm | |
| 436.1MXRLZ-375 | 72748 | 350-375mm | |
| 436.1MXRLZ-400 | 72749 | 375-400mm | |
| 436.1MXRLZ-425 | 72750 | 400-425mm | |
| 436.1MXRLZ-450 | 72751 | 425-450mm | |
| 436.1MXRLZ-475 | 72752 | 450-475mm | |
| 436.1MXRLZ-500 | 72453 | 475-500mm | |
| 436.1MXRLZ-525 | 72754 | 500-525mm | |
| 436.1MXRLZ-550 | 72755 | 525-550mm | |
| 436.1MXRLZ-575 | 72756 | 550-575mm | |
| 436.1MXRLZ-600 | 72757 | 575-600mm | |

25-150mm models sent in fitted plastic case. 175-300mm models sent without case, packed one each to a box.
325-600mm models are furnished in a case at no extra charge.

MEASURING RODS AND STANDARDS CAN BE FOUND ON PAGE 76



| Holster and Cases for Inch and Millimeter Micrometers | | |
|---|-------|---|
| Cat. No. | EDP | Description |
| 914 | 64165 | Leather holster for 1" (25mm) micrometers |
| 910 | 55397 | Case for 1" (25mm) micrometers |
| 913 | 55400 | Case for 2" (50mm) micrometers |
| 922 | 55222 | Case for 3" (75mm) micrometers |
| 952 | 55223 | Case for 4" (100mm) micrometers |
| 953 | 55224 | Case for 5" (125mm) micrometers |
| 954 | 55225 | Case for 6" (150mm) micrometers |
| 930 | 55276 | Case for 7" (175mm) micrometers |
| 931 | 55277 | Case for 8" (200mm) micrometers |
| 932 | 55278 | Case for 9" (225mm) micrometers |
| 933 | 55279 | Case for 10" (250mm) micrometers |
| 934 | 55280 | Case for 11" (275mm) micrometers |
| 935 | 55281 | Case for 12" (300mm) micrometers |



MICROMETER SETS

S436.1 MICROMETER SETS WITH STANDARDS, IN ATTRACTIVE, PROTECTIVE CASES

0-24" (0-600MM)

Recommended for mechanics, automotive service and machine shops, toolrooms, inspection departments, and wherever gaging involves a wide range of measurements. All sets come with attractive, protective cases which keep micrometers and standards together, readily accessible.

For further information on each type of micrometer, refer to the listing on the previous pages.



ST436.1AXRLZ

S436.1 Micrometer Sets

| Cat. No. | EDP | Range | Graduation | Set Description |
|--------------|-------|-------|------------|---|
| S436.1ARLZ | 68035 | 0-3" | .001" | Each Set Includes: 1", 2" and 3" micrometers, with two standards |
| S436.1AXRLZ | 68036 | | | |
| ST436.1AXRLZ | 68037 | | | |
| ST436.1AXFLZ | 68038 | | .0001" | |
| S436.1BRLZ | 68039 | 0-4" | .001" | Each Set Includes: 1", 2", 3" and 4" micrometers, with three standards |
| S436.1BXRLZ | 68040 | | | |
| ST436.1BXRLZ | 68041 | | | |
| ST436.1BXFLZ | 68042 | | .0001" | |
| S436.1CRLZ | 68043 | 0-6" | .001" | Each Set Includes: 1", 2", 3", 4", 5" and 6" micrometers, with five standards |
| S436.1CXRLZ | 68044 | | | |
| ST436.1CXRLZ | 68045 | | | |
| ST436.1CXFLZ | 68046 | | .0001" | |

S436 Micrometer Sets

| Cat. No. | EDP | Range | Graduation | Set Description |
|------------|-------|--------|------------|--|
| S436ERLZ | 51931 | 0-12" | .001" | Each Set Includes: 1", 2", 3", 4", 5", 6", 7", 8", 9", 10", 11" and 12" micrometers, with eleven standards |
| S436EXRLZ | 52012 | | | |
| ST436EXRLZ | 52030 | | .0001" | |
| S436DRLZ | 51919 | 6-12" | .001" | Each Set Includes: 7", 8", 9", 10", 11" and 12" micrometers, with six standards |
| S436DXRLZ | 64463 | | | |
| ST436DXRLZ | 64465 | | .0001" | |
| S436FXRLZ | 64466 | 12-24" | .001" | Set Includes: 13", 14", 15", 16", 17", 18", 19", 20", 21", 22", 23" and 24" micrometers, with twelve standards |

Box type cases available for sets 0-6", 6-12", 12-24" with 6, 12, or 24 micrometers and flat type cases available for sets 0-3" or 0-4" with 3 or 4 micrometers.

S436.1M Micrometer Sets

| Cat. No. | EDP | Range | Graduation | Set Description |
|---------------|-------|---------|------------|--|
| S436.1MARLZ | 68067 | 0-75mm | 0.01mm | Each Set Includes: 25mm, 50mm and 75mm micrometers, with two standards |
| S436.1MAXRLZ | 68068 | | | |
| SV436.1MAXRLZ | 68069 | | 0.001mm | |
| S436.1MBRLZ | 68070 | 0-100mm | 0.01mm | Each Set Includes: 25mm, 50mm, 75mm and 100mm micrometers with three standards |
| S436.1MBXRLZ | 68071 | | | |
| SV436.1MBXRLZ | 68072 | | 0.001mm | |
| S436.1MCRLZ | 68073 | 0-150mm | 0.01mm | Each Set Includes: 25mm, 50mm, 75mm, 100mm, 125mm and 150mm micrometers, with five standards |
| S436.1MCXRLZ | 68074 | | | |
| SV436.1MCXRLZ | 68075 | | 0.001mm | |

S436M Micrometer Sets

| Cat. No. | EDP | Range | Graduation | Set Description |
|------------|-------|-----------|------------|--|
| S436MEXRLZ | 52014 | 0-300mm | 0.01mm | Set Includes: 25, 50, 75, 100, 125, 150, 175, 200, 225, 250, 275 and 300mm micrometers, with eleven standards |
| S436MDXRLZ | 64461 | 150-300mm | 0.01mm | Set Includes: 175, 200, 225, 250, 275 and 300mm micrometers, with six standards |
| S436MFXRLZ | 64462 | 300-600mm | 0.01mm | Set Includes: 325, 350, 375, 400, 425, 450, 475, 500, 525, 550, 575 and 600mm micrometers, with twelve standards |

Box type cases available for sets 0-150mm, 150-300mm, 300-600mm with 6, 12, or 24 micrometers and flat type cases available for sets 0-75mm or 0-100mm with 3 or 4 micrometers.

Cases for S436.1 and S436 Micrometer Sets

| Cat. No. | EDP | Description |
|----------|-------|--------------------------|
| 955 | 55226 | Case only for S436A sets |
| 936 | 55295 | Case only for S436B sets |
| 956 | 55227 | Case only for S436C sets |
| 938 | 55298 | Case only for S436E sets |
| 937 | 55297 | Case only for S436D sets |
| S436FZZ | 64339 | Case only for S436F sets |

* Includes redemption card for Standard Letter of Certification (SLC).

MEASURING RODS AND STANDARDS CAN BE FOUND ON PAGE 76



ANVIL MICROMETERS

224.1 MECHANICAL INTERCHANGEABLE ANVIL MICROMETER

0-24"/0-600MM

Increased flexibility by offering a wide range of measurements. The 224 Satin-Chrome Micrometers are very popular in machine or automotive repair shops and for all applications requiring a single micrometer with range greater than 1".

Each micrometer is equipped with a series of easily interchangeable anvils, thus providing the full range in steps of 1" or 25mm with a single micrometer. Suitable wrenches are furnished to make necessary adjustments.

These larger sizes have .300" (7.6mm) anvil and spindle diameters for ease of use on larger work.

224, 224M, 224.1, 24.1M Interchangeable Anvil Micrometers

| With Ratchet Stop, Lock Nut, In Case | | Range | Graduation | 234 Standards Furnished |
|--------------------------------------|-------|-----------|--------------------|--------------------------------|
| Cat. No. | EDP | | | |
| 224AARLZ | 50770 | 0-4" | .001" | 1", 2", 3" |
| 224ARLZ | 50772 | 2-6" | | 2", 3", 4", 5" |
| 224.1BRLZ | 72700 | 6-9" | | 6", 7", 8" |
| 224.1GRLZ | 72704 | 6-12" | | 6", 7", 8", 9", 10", 11" |
| 224.1CRLZ | 72701 | 9-12" | | 9", 10", 11" |
| 224.1DRLZ | 72702 | 12-16" | | 12", 13", 14", 15" |
| 224.1ERLZ | 72703 | 16-20" | | 16", 17", 18", 19" |
| 224.1JRLZ | 72705 | 20-24" | 20", 21", 22", 23" | |
| 224MAARLZ | 50771 | 0-100mm | 0.01mm | 25, 50, 75mm |
| 224MARLZ | 50773 | 50-150mm | | 50, 75, 100, 125mm |
| 224.1MGRLZ | 72708 | 150-300mm | | 150, 175, 200, 225, 250, 275mm |
| 224.1MDRLZ | 72706 | 300-400mm | | 300, 325, 350, 375mm |
| 224.1MERLZ | 72707 | 400-500mm | | 400, 425, 450, 475mm |
| 224.1MJRLZ | 72709 | 500-600mm | | 500, 525, 550, 575mm |

Micrometer furnished in attractive, protective case.

READABILITY FEATURES

- Starrett satin chrome finish – no glare – resists rust
- Advanced sleeve design with staggered lines and distinct figures for precise and easy readability
- Large thimble diameter with distinct figures

EASE-OF-HANDLING FEATURES

- Balanced frame and thimble design ensure easy handling and better readability
- Ring-type knurled lock nut for quick and sure locking
- Combination ratchet and speeder for uniform pressure and quicker adjustment

ACCURACY AND LONG-LIFE FEATURES

- Rigid and stable special cast iron frame with appropriate perforations for lightness and ribbed for strength and stability
- Extremely hard and stable one-piece spindle (the heart of our accuracy)
- Quick and easy sleeve adjustment



224.1CRLZ



ANVIL MICROMETERS

714 ELECTRONIC INTERCHANGEABLE ANVIL OUTSIDE MICROMETERS (WITH OUTPUT)

0-24"/0-600MM

This micrometer is the same as our 224 Micrometers except that it has an electronic readout and the following extra features and benefits:

714 Electronic Interchangeable Anvil Micrometers With Standard Inch Graduations on Shell and Thimble

| Cat. No. | EDP | Range | | Resolution | |
|----------|-------|-------|------------|------------|-------|
| | | in | Approx. mm | in | mm |
| 714AAFLZ | 64427 | 0-4 | 0-101 | .00005 | 0.001 |
| 714AFLZ | 64428 | 2-6 | 51-152 | .0001 | 0.001 |
| 714BFLZ | 64429 | 6-9 | 152-228 | | |
| 714GFLZ | 64430 | 6-12 | 152-305 | | |
| 714CFLZ | 64431 | 9-12 | 228-305 | | |
| 714DFLZ | 64432 | 12-16 | 305-406 | | |
| 714EFLZ | 64433 | 16-20 | 406-508 | | |
| 714JFLZ | 64434 | 20-24 | 508-609 | | |

714M Electronic Interchangeable Anvil Micrometers With Standard Millimeter Graduations on Shell and Thimble

| Cat. No. | EDP | Range | | Resolution | |
|------------|-------|---------|---------------|------------|--------|
| | | mm | Approx. in | mm | in |
| 714MEAAFLZ | 66108 | 0-100 | 0-3.930 | 0.001 | .00005 |
| 714MEAFLZ | 66109 | 50-150 | 1.968-5.900 | 0.001 | .0001 |
| 714MEGFLZ | 66111 | 150-300 | 5.900-11.810 | | |
| 714MEDFLZ | 66112 | 300-400 | 11.810-15.740 | | |
| 714MEEFLZ | 66113 | 400-500 | 15.740-19.680 | | |
| 714MEJFLZ | 66110 | 500-600 | 19.680-23.620 | | |

Cable Information for 714 and 714M Electronic Interchangeable Anvil Micrometers

| Part No. | EDP | Description |
|----------|-------|--|
| PT61963 | 66636 | Computer Interface Cable Complete to PC (RS232C) |
| 733SCKB | 69888 | USB cable to PC (In focused window) |
| 733SCU | 69898 | USB cable to computer running SPC Data Collection Software |
| 733SCM | 69893 | Connection to Multiplexer (7612, 7613 or RMS 2704) |
| PT61120 | 65446 | One 3-Volt Battery CR2450 |

Adjusting wrenches furnished with each tool.
Micrometer furnished in protective case with 234 Standards.

READABILITY FEATURES

- Large, right-sized, high-contrast LCD digital readout is easy to read and reduces errors
- Resolution – .00005" and 0.001mm
- Conventional inch or millimeter graduations standard
- Starrett no-glare satin chrome finish on thimble and sleeve

ACCURACY AND LONG-LIFE FEATURES

- One 3-volt battery furnished for dependable power and over one year's normal usage
- Automatic OFF after 30 minutes of nonuse

FULL-FUNCTION ACTION FEATURES

- Instant inch/millimeter conversion
- "ME" millimeter models will turn on in the millimeter mode after installation of a new battery
- Measurement HOLD button
- Ability to zero tool at any position
- Ability to retain and return to the true zero reading of the micrometer
- PRESET button to install any reading at any position
- Ability to install minimum and maximum limits
- Output data to Starrett SPC Plus hardware and software and to PCs
- Works well with Starrett DataSure® Wireless Data Collection Systems



714MEAAFLZ

714EFLZ



TUBULAR MICROMETERS

724 TUBULAR BOW TYPE MICROMETERS WITH INTERCHANGEABLE ANVILS

12-60"/300 -1500MM

These micrometers are made for more precise measurements on large outside dimensions. They provide perfect balance, sensitive feel, ease of handling, and less measuring effort due to their advanced tubular design. Frames are built of special steel formed to exacting tubular design specifications and welded by a carefully controlled process. This produces a hollow tubular frame of the lightest weight, extreme rigidity, and a standard coefficient of expansion.

Because of the interchangeable anvils, the 724 is well suited for diversified gaging and provides a wide range of measurement in steps of 1 inch or 25mm.

The micrometer head has a larger diameter anvil and spindle at .300" (7.6mm). This provides greater balance and larger bearing surface on the threads.

| 724 Tubular Bow Type Micrometers | | | | |
|-----------------------------------|-------|------------|------------|--------------------------------|
| With Lock Nut, In Case | | | | |
| Cat. No. | EDP | Range (in) | Graduation | 234 Standards Furnished |
| 724LZ-18 | 52994 | 12-18 | .001" | 12", 13", 14", 15", 16", 17" |
| 724LZ-24 | 52995 | 18-24 | | 18", 19", 20", 21", 22", 23" |
| 724LZ-30 | 52996 | 24-30 | | 25", 27", 29" |
| 724LZ-36 | 52997 | 30-36 | | 31", 33", 35" |
| 724LZ-42 | 52998 | 36-42 | | 37", 39", 41" |
| 724LZ-48 | 52999 | 42-48 | | 43", 45", 47" |
| 724LZ-54 | 53000 | 48-54 | | 49", 51", 53" |
| 724LZ-60 | 53001 | 54-60 | | 55", 57", 59" |
| 724M Tubular Bow Type Micrometers | | | | |
| With Lock Nut, In Case | | | | |
| Cat. No. | EDP | Range (mm) | Graduation | 234 Standards Furnished |
| 724MLZ-450 | 64318 | 300-450 | 0.01mm | 300, 325, 350, 375, 400, 425mm |
| 724MLZ-600 | 64319 | 450-600 | | 450, 475, 500, 525, 550, 575mm |
| 724MLZ-750 | 64320 | 600-750 | | 625, 675, 725mm |
| 724MLZ-900 | 64321 | 750-900 | | 775, 825, 875mm |
| 724MLZ-1050 | 64322 | 900-1050 | | 925, 975, 1025mm |
| 724MLZ-1200 | 64323 | 1050-1200 | | 1075, 1125, 1175mm |
| 724MLZ-1350 | 64324 | 1200-1350 | | 1225, 1275, 1325mm |
| 724MLZ-1500 | 64325 | 1350-1500 | | 1375, 1425, 1475mm |

Adjusting wrenches furnished with each tool.
Furnished with 234 Standards in attractive, protective case.

READABILITY FEATURES

- Starrett satin chrome finish – no glare – resists rust
- Advanced sleeve design with staggered lines and distinct figures for precise and easy readability
- Large thimble diameter with distinct figures

EASE-OF-HANDLING FEATURES

- Balanced frame and thimble design for easy handling and better readability
- Ring-type knurled lock nut for quick and sure locking
- Hollow tubular frame design combining lightest possible weight with rigidity

ACCURACY AND LONG-LIFE FEATURES

- Extremely hard and stable one-piece spindle (the heart of our accuracy)
- Standards with insulated grips
- It is recommended that these micrometers be checked with standards in the approximate position (vertical or horizontal) that they will be used. We do not recommend .0001" or 0.001mm readings on these micrometers. Larger sizes, carbide faces and ratchet stop are available on special order.



724LZ-18



TUBULAR MICROMETERS

736 TUBULAR BOW TYPE MICROMETERS WITH FIXED ANVIL

12-30"/300-750MM

This micrometer is similar to the 724 Micrometer. All features are identical to the 724, except that it has a fixed anvil, and is furnished in inch and millimeter sizes from 12-30" and 25mm increments from 300-750mm.

Order by catalog number and range through our Special Order Department. Example: 736LZ-28 (this orders a micrometer with a 27-28" range with lock nut and standard, in an attractive, protective case.)

A fixed anvil makes it easier to gage an outside diameter because the balance of the gage is proportional to the part being measured.

READABILITY FEATURES

- Starrett satin chrome finish – no glare – resists rust
- Advanced sleeve design with staggered lines and distinct figures for precise and easy readability
- Large thimble diameter with distinct figures

EASE-OF-HANDLING FEATURES

- Balanced frame and thimble design ensure easy handling and better readability
- Ring-type knurled lock nut for quick and sure locking

ACCURACY AND LONG-LIFE FEATURES

- Hollow tubular frame design combining lightest possible weight with rigidity
- Extremely hard and stable one-piece spindle (the heart of our accuracy)
- 234 Standards furnished with micrometers



736LZ-31

ULTRALIGHT "C" FRAME GAGES

Rigid honeycomb aluminum diameter gage weighs five times less than solid frame gages. Unit shown has interchangeable anvils for 36-42" range. The gage is used as a dial indicator snap gage set to produce nominal dimension, or as an indicating micrometer. The micrometer head with .0001" graduations and the .0005" dial indicator ensure quick, accurate readings.

Ultralights are available from 24-72" (600-1800mm) I.D. or O.D. and can be designed for up to 72" (1800mm) throat depth for thickness measurement.

MICROMETER STANDS

3206 OUTSIDE MICROMETER STAND

- This stand converts outside micrometers to a sturdy bench gage for batch inspection of small parts
- Useful as a handy bench vise or assembly fixture
- Gripping surfaces are two nylon pads which are replaceable
- Ball joint construction allows head to be positioned as much as 30° off perpendicular in any direction
- Positive lock on the base
- Base dimension is 6-3/8" long x 3-1/2" wide x 3/4" thick (162mm long x 89mm wide x 19mm thick)
- Tilting head clamping capability is 3/4" (19mm) thick x 1" (25mm) throat depth
- Accommodates all Starrett 1/2" (13mm) and 1" (25mm) outside micrometers, 2 and 2A 2" outside micrometers and 210, 220, 430, 483, 485 and 569 Special Purpose Outside Micrometers

3206 Outside Micrometer Stand

| Cat. No. | EDP | Description |
|----------|-------|--------------------------|
| 3206 | 68917 | Outside Micrometer Stand |



SPECIAL FUNCTION MICROMETERS

MICROMETER HEAD SPEEDS GAGING

Unique applications can require unique tools. Starrett is constantly building special tools in large and small quantities with unique functionality. Special function micrometers have unique frames, contacts, readouts, or other components that will meet your requirements. Quotations and a concept print for your application can be obtained by submitting a product drawing with the thickness dimension(s) circled to:

The L.S. Starrett Co.
 Special Gage Division
 121 Crescent Street
 Athol, MA 01331-1915.



Special 436 Micrometer with dial indicator head. Range 3-4" (75-100mm). Other ranges also available.



Starrett can manufacture extra large micrometers, like this special 724 Micrometer of tubing type construction, range 72-78" (1800-1950mm), with interchangeable anvils.

CONTACTS

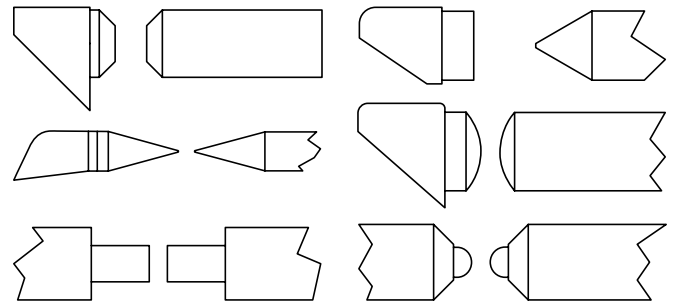

SPECIAL 725 DEEP THROAT TUBULAR MICROMETER

With sliding, interchangeable anvils and locking lever, 7-1/2" (185mm) depth, 0-6" (0-150mm) range.



SPECIAL FUNCTION MICROMETERS

Throughout its history, The L.S. Starrett Company has manufactured a multitude of special hand tools and gages for thousands of customers in many different industries. Illustrated on these first two pages are typical examples of Starrett special toolmaking. The following pages show special function tools that we make as regular items because they are commonly used in industry.

Special toolmaking activities are coordinated under the direction of special order sales engineers who oversee each order from the time it is entered until shipment is made. Complete manufacturing facilities and engineering counsel are available.

Customers are invited to submit drawings and specifications for prompt quotation. Please direct these to the attention of:

The L.S. Starrett Company
 Special Order Department
 121 Crescent Street
 Athol, MA 01331-1915



MUL-T-ANVIL MICROMETERS

220 MUL-T-ANVIL MICROMETERS

0-2"/0-50MM

This tool was a new development in micrometer design and patent is held by Starrett. This micrometer will handle a wide variety of measurements impossible to obtain with regular micrometers, such as measuring the wall thickness of tubing, cylindrical walls from a hole or slot to an edge, many hard-to-reach locations, and the thickness of screw heads, shoulder lengths, etc.

This micrometer can be furnished with .0001" graduations, but we recommend .001" or 0.01mm for easier and more accurate readings. The Starrett Company, with our years of experience, recommends this because the anvils on this type of tool are not backed up by a frame as in a regular micrometer and could bend slightly.

220 Mul-T-Anvil Micrometers with Round and Flat Anvils and Carbide Faced Spindle

| Ratchet Stop, Lock Nut | | Friction Thimble, Lock Nut | | Range | Graduation |
|------------------------|-------|----------------------------|-------|------------------|------------|
| Cat. No. | EDP | Cat. No. | EDP | | |
| 220XRL-1 | 66430 | 220XFL-1 | 50746 | 0-1" | .001" |
| 220MXRL-25 | 65050 | | | 0-25mm | 0.01mm |
| 220ZZ-1 | 55209 | | | Deluxe Case Only | |

220M Mul-T-Anvil Micrometers With Round and Flat Anvils, Carbide Faced Spindle and 234B-1" or 234MB-25mm End Measuring Rod or Standard

| Ratchet Stop, Lock Nut | | Friction Thimble, Lock Nut | | Range | Graduation |
|------------------------|-------|----------------------------|-------|------------------|------------|
| Cat. No. | EDP | Cat. No. | EDP | | |
| 220XRL-2 | 66432 | 220XFL-2 | 66433 | 1-2" | .001" |
| 220MXRL-50 | 66434 | | | 25-50mm | 0.01mm |
| 220ZZ-2 | 55210 | | | Deluxe Case Only | |

V-Anvil only: Order PT13017, EDP 71399
 1" and 25mm models sent in fitted case.
 2" and 50mm models packed one in a box without case.

READABILITY FEATURES

- Starrett satin chrome finish – no glare – resists rust
- Advanced sleeve design with staggered lines and distinct figures for precise and easy readability
- Quick-reading figures – every thousandth numbered on inch tools

EASE-OF-HANDLING FEATURES

- Balanced frame and thimble design ensure easy handling, better readability
- Ring-type knurled lock nut for quick and sure locking
- A choice of friction thimble or combination ratchet/speeder for uniform pressure
- Interchangeable anvils are rigidly held in the vise type frame and quickly interchanged by a single lock screw adjustment
- Two hardened anvils furnished – round anvil approximately .120" diameter (3mm) and flat anvil approximately .125" (3mm) and .060" (1.5mm) thick
- "V" Anvil for measuring thickness of screw heads and shoulder lengths available separately
- Accommodates special anvils up to 5/16" (8mm) thick
- Can be used as a height gage by removing the vise jaw

ACCURACY AND LONG-LIFE FEATURES

- Rigid one-piece frame of drop forged steel
- Extremely hard and stable one-piece spindle (the heart of our accuracy)
- Quick and easy adjustment
- Tool is accurate to $\pm .0002"$ or $\pm 0.004\text{mm}$



220XRL-2



MUL-T-ANVIL MICROMETERS

790 ELECTRONIC MULTI-ANVIL MICROMETERS (WITH OUTPUT)

0-1"/0-25MM

Same as our 220 Micrometer with electronic readout.

790 Electronic Multi-Anvil Micrometers with Standard Inch Graduations on Shell and Thimble with Round and Flat Anvils

| Cat. No. | EDP | Description |
|----------|-------|-------------------|
| 790AFL-1 | 64048 | 0-1"/0-25mm Range |

790M Electronic Multi-Anvil Micrometers with Standard Millimeter Graduations on Shell and Thimble with Round and Flat Anvils

| Cat. No. | EDP | Description |
|-------------|-------|-------------------|
| 790MEAFL-25 | 66071 | 0-25mm/0-1" Range |

Cable Information

| Cat. No. | EDP | Description |
|----------|-------|--|
| 733SCKB | 69888 | USB cable to PC (In focused window) |
| 733SCU | 69898 | USB cable to computer running SPC Data Collection Software |
| 733SCM | 69893 | Connection to Multiplexer (7612, 7613 or RMS 2704) |
| PT61963 | 66636 | Computer Interface Cable Complete to PC (RS232C) |
| PT61120 | 65446 | One 3-Volt Battery CR2450 |



790AFL

READABILITY FEATURES

- Large LCD digital readout is easy to read and reduces errors
- Resolution – .00005" and 0.001mm
- Conventional inch or millimeter graduations standard
- Attractive no-glare black wrinkle finish on the frame
- Starrett no-glare satin chrome finish on thimble and sleeve

ACCURACY AND LONG-LIFE FEATURES

- One 3-volt battery furnished for over a year of normal usage
- Automatic OFF after 30 minutes of nonuse
- Tool is accurate to $\pm .0002"$ or $\pm 0.004mm$

FULL-FUNCTION ACTION FEATURES

- Instant inch/millimeter conversion
- "ME" millimeter model will turn on in the millimeter mode after installation of a new battery
- Measurement HOLD button
- Ability to zero tool at any position
- Ability to retain and return to the true zero reading of the micrometer
- PRESET button to install any reading at any position
- Ability to install minimum and maximum limits
- Output data to Starrett SPC Plus hardware and software and to PCs
- Works well with Starrett DataSure® Wireless Data Collection Systems



SHEET METAL MICROMETERS

222 SHEET METAL MICROMETERS

0-1"/0-25MM

These micrometers reach over the edge of sheet metal and take measurements away from the edge toward the center. Also for other gaging jobs where a deep throat micrometer is needed. Rounded anvil on 1" (25mm) size gives a point contact for more accurate gaging; flat anvil is also available. The 1/2" and 13mm micrometers have satin chrome frames; 1" and 25mm micrometer frames have black wrinkle finish.

| 222 Sheet Metal Micrometers, 2" Throat Depth (0-1/2" Range) | | | |
|---|-------|--------------------------|------------|
| Cat. No. | EDP | Anvil | Graduation |
| 222RL-1/2 | 50756 | Flat | .001" |
| 222XRL-1/2 | 50757 | Flat | .001" |
| 222 Sheet Metal Micrometers, 6" Throat Depth (0-1" Range) | | | |
| Cat. No. | EDP | Anvil | Graduation |
| 222AXR-1 | 50762 | Rounded | .001" |
| 222BXR-1 | 50763 | Flat | .001" |
| 222M Sheet Metal Micrometers, 50mm Throat Depth (0-13mm Range) | | | |
| Cat. No. | EDP | Anvil | Graduation |
| 222MRL-13 | 50758 | Flat | 0.01mm |
| 222M Sheet Metal Micrometers, 150mm Throat Depth (0-25mm Range) | | | |
| Cat. No. | EDP | Anvil | Graduation |
| 222MAXR-25 | 66435 | Rounded | 0.01mm |
| 222MBXR-25 | 66436 | Flat | 0.01mm |
| Case for 222 and 222M Sheet Metal Micrometers | | | |
| Cat. No. | EDP | Description | |
| 222ZZ-1 | 55212 | Case for 222 Micrometers | |

0-1" range and 0-25mm range micrometers sent with rounded anvil unless otherwise ordered. Packed one in a box without case.

READABILITY FEATURES

- Starrett satin chrome finish – no glare – resists rust
- Advanced sleeve design with staggered lines and distinct figures for precise and easy readability
- Convenient decimal equivalents on Inch tools

EASE-OF-HANDLING FEATURES

- Balanced frame and thimble design ensure easy handling and better readability
- Combination ratchet and speeder for uniform pressure and quicker adjustment
- Ring-type knurled lock nut for quick and sure locking (on 1/2" and 13mm range models)

ACCURACY AND LONG-LIFE FEATURES

- Rigid one-piece frame of drop forged steel, ribbed for strength and stability
- Extremely hard and stable one-piece spindle (the heart of our accuracy)
- Quick and easy adjustment

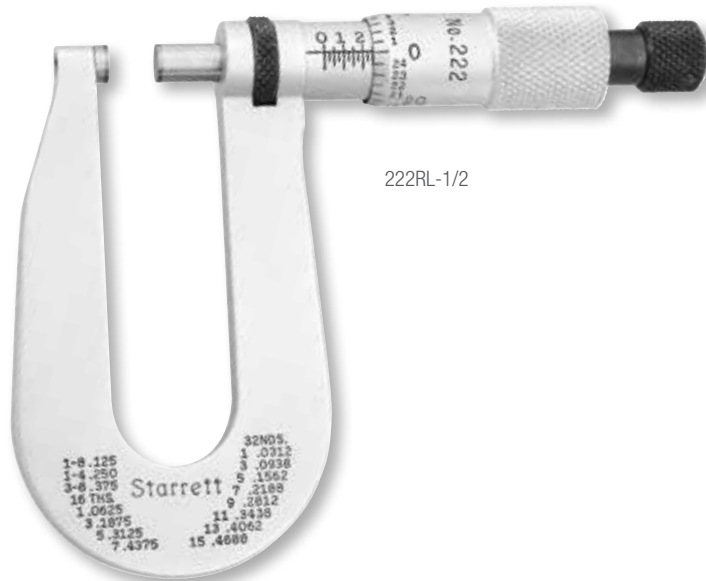

SHEET METAL MICROMETERS

764 ELECTRONIC SHEET METAL MICROMETERS (WITH OUTPUT)

0-1"/0-25MM

This micrometer is the same as our 222 Micrometer, except that it has an electronic readout and is available in the 1" (25mm) and 25mm ranges. Rounded anvil gives a point contact for more accurate gaging; flat anvil also available.

764 Electronic Sheet Metal Micrometers, 6" Throat Depth with Standard Inch Graduations on Shell and Thimble

| Cat. No. | EDP | Description |
|----------|-------|--------------------------------|
| 764AXFL | 66445 | 0-1"/0-25mm Range, Round Anvil |
| 764BXFL | 66525 | 0-1"/0-25mm Range, Flat Anvil |

764M Electronic Sheet Metal Micrometers, 150mm Throat Depth with Standard Millimeter Graduations on Shell and Thimble

| Cat. No. | EDP | Description |
|-----------|-------|--------------------------------|
| 764MEAXFL | 66446 | 0-25mm/0-1" Range, Round Anvil |

Cable Information for 764 and 764M Electronic Sheet Metal Micrometers

| Part No. | EDP | Description |
|----------|-------|--|
| PT61963 | 66636 | Computer Interface Cable Complete to PC (RS232C) |
| 733SCKB | 69888 | USB cable to PC (In focused window) |
| 733SCU | 69898 | USB cable to computer running SPC Data Collection Software |
| 733SCM | 69893 | Connection to Multiplexer (7612, 7613 or RMS 2704) |
| PT61120 | 65446 | One 3-Volt Battery CR2450 |

Packed one in a box without case.



764AXFL

READABILITY FEATURES

- Large, right-sized, high-contrast LCD digital readout is easy to read and reduces errors
- Resolution: .00005" and 0.001mm
- Conventional inch or millimeter graduations standard
- Attractive no-glare black wrinkle finish on the frame
- Starrett no-glare satin chrome finish on thimble and sleeve

ACCURACY AND LONG-LIFE FEATURES

- One 3-volt battery furnished for over a year of normal usage
- Automatic OFF after 30 minutes of nonuse

FULL-FUNCTION ACTION FEATURES

- Instant inch/millimeter conversion
- "ME" millimeter model will turn on in the millimeter mode after installation of a new battery
- Measurement HOLD button
- Ability to zero tool at any position
- Ability to retain and return to the true zero reading of the micrometer
- PRESET button to install any reading at any position
- Ability to install minimum and maximum limits
- RS232 data output port
- Works well with Starrett DataSure® Wireless Data Collection Systems

TUBE MICROMETERS

569 TUBE MICROMETERS

0-1"/0-25MM

For measuring the wall thickness of tubing and other parts with cylindrical walls. Also for measuring from a hole to an edge (note minimum hole sizes in table). Rigid steel "half" frame with smooth black enamel finish. Anvil diameter = 0.185".

READABILITY FEATURES

- Starrett satin chrome finish – no glare – resists rust
- Advanced sleeve design with staggered lines and distinct figures for precise and easy readability
- Convenient decimal equivalents on inch tools

EASE-OF-HANDLING FEATURES

- Balanced frame and thimble design ensure easy handling and better readability

ACCURACY AND LONG-LIFE FEATURES

- Rigid steel frame ribbed for strength and stability
- Extremely hard and stable one-piece spindle (the heart of our accuracy)
- Quick and easy adjustment

| 569 Tube Micrometers (0-1" Range) | | | | |
|---|-------|------------------------------|-------------------|-----------------------|
| Cat. No. | EDP | Graduation | Minimum Hole Size | Description |
| 569AXP | 66437 | .001" | 3/16" | Carbide Faced Spindle |
| 569BXP | 66439 | | 3/8" | Carbide Faced Spindle |
| 569M Tube Micrometers (0-25mm Range) | | | | |
| Cat. No. | EDP | Graduation | Minimum Hole Size | Description |
| 569MAXP | 66438 | 0.01mm | 4.8mm | Carbide Faced Spindle |
| 569MBXP | 66440 | | 9.5mm | Carbide Faced Spindle |
| Deluxe Case for 569 and 569M Tube Micrometers | | | | |
| Cat. No. | EDP | Description | | |
| 910 | 55397 | Deluxe case only for the 569 | | |

Special anvils also can be furnished, priced on application. Sent in fitted case.

769 ELECTRONIC TUBE MICROMETERS (WITH OUTPUT)

0-1"/0-25MM

This micrometer is the same as our 569 with an electronic readout and the following additional features and benefits:

READABILITY FEATURES

- Large LCD digital readout is easy to read and reduces errors
- Resolution: .00005" and 0.001mm
- Conventional inch or millimeter graduations standard
- Attractive no-glare black wrinkle finish on the frame
- Starrett no-glare satin chrome finish on thimble and sleeve

ACCURACY AND LONG-LIFE FEATURES

- One 3-volt battery furnished for over a year of normal usage
- Automatic OFF after 30 minutes of nonuse

FULL-FUNCTION ACTION FEATURES

- Instant inch/millimeter conversion
- "ME" model turns on in millimeter mode after battery installation
- Measurement HOLD button
- Ability to zero tool at any position
- Ability to retain and return to the true zero reading of the micrometer
- PRESET button to install any reading at any position
- Ability to install minimum and maximum limits
- RS232 data output port
- Works well with Starrett DataSure® Wireless Data Collection Systems

| 769 Electronic Tube Micrometers, Standard Inch Graduations | | |
|--|-------|--|
| Cat. No. | EDP | Description |
| 769AXFL | 66447 | 0-1"/0-25mm Range, Carbide Faced Spindle |
| 769 Electronic Tube Micrometers, Standard Millimeter Graduations | | |
| Cat. No. | EDP | Description |
| 769MEAXFL | 66448 | 0-25mm/0-1" Range, Carbide Faced Spindle |
| Cable Information for 769 Electronic Tube Micrometers | | |
| Part No. | EDP | Description |
| PT61963 | 66636 | Computer Interface Cable Complete to PC (RS232C) |
| 733SCKB | 69888 | USB cable to PC (In focused window) |
| 733SCU | 69898 | USB cable to computer running SPC Data Collection Software |
| 733SCM | 69893 | Connection to Multiplexer (7612, 7613 or RMS 2704) |
| PT61120 | 65446 | One 3-Volt Battery CR2450 |



CRANKSHAFT MICROMETERS

436 AUTOMOTIVE MICROMETERS

1-1/2– 3-1/2"/38-88MM

This micrometer is designed for automotive work and especially for crankshaft measuring. It is also well suited for all other work within its capacity. It measures the diameter of the journal bearing and main bearing of most crankshafts since the micrometer has a range from 1-1/2" (38mm) – 3-1/2" (88mm).

436-3 1/2 Automotive Crankshaft Micrometers (1-1/2 – 3-1/2" Range)

| Cat. No. | EDP | Graduation |
|---------------|-------|------------|
| T436RLS-3 1/2 | 65493 | .0001" |

436M-88 Automotive Crankshaft Micrometers (38-88mm Range)

| Cat. No. | EDP | Graduation |
|-------------|-------|------------|
| V436MRLS-88 | 65600 | 0.002mm |

Case for 436-3 1/2 and 436M-88 Automotive Crankshaft Micrometers

| Cat. No. | EDP | Description |
|----------|-------|-----------------|
| 733ZZ-4 | 66139 | Protective Case |

Carbide measuring faces available on special order. Specify "X" after catalog number.



T436RLS-3 1/2

READABILITY FEATURES

- Starrett satin chrome finish – no glare – resists rust
- Advanced sleeve design with staggered lines and distinct figures for precise and easy readability
- Quick-reading figures – every thousandth numbered on inch tools
- The reading point is on the under side of the sleeve, plainly visible while measuring. It's a very useful feature when measuring between webs.

EASE-OF-HANDLING FEATURES

- Balanced frame and thimble design ensure easy handling and better readability
- Ring-type knurled lock nut for quick and sure locking
- Combination ratchet and speeder for uniform pressure and quicker adjustment
- Gracefully designed tapered frame for use in narrow slots and tight places
- 2" (50mm) range
- 2-5/8" (66mm) throat depth

ACCURACY AND LONG-LIFE FEATURES

- Rigid one-piece frame of drop forged steel, ribbed for extra strength
- Extremely hard and stable one-piece spindle (the heart of our accuracy)
- Appropriate standard included



MICROMETERS

458 AUTOMOTIVE DISC BRAKE MICROMETERS

.300-2"/7.6-50MM

- Measures depth of wear grooves in disc of brake systems
- 3" (75mm) frame with a 3-1/2" (88mm) depth to allow additional reach
- Flat carbide spindle and a carbide anvil with a 60° point

READABILITY FEATURES

- Starrett satin chrome finish – no glare – resists rust
- Advanced sleeve design for precise, easy readability
- Quick-reading figures – every thousandth numbered on inch tools

EASE-OF-HANDLING FEATURES

- Balanced frame and thimble design ensure easy handling and better readability
- Combination ratchet and speeder for uniform pressure and quicker adjustment
- Gracefully designed tapered frame for use in narrow slots and tight places
- 3-1/2" (88mm) throat depth

ACCURACY AND LONG-LIFE FEATURES

- Rigid one-piece steel frame
- Extremely hard and stable one-piece spindle (the heart of our accuracy)
- Carbide measuring face on the spindle and carbide "V" anvil
- Quick and easy adjustment

260 GROOVE MICROMETERS

INCH/MM

Quickly and easily measures widths of internal or external grooves and lands.

READABILITY FEATURES

- Starrett satin chrome finish – no glare – resists rust
- Advanced sleeve design with staggered lines and distinct figures for precise and easy readability
- Quick-reading figures – every thousandth numbered on inch tools

EASE-OF-HANDLING FEATURES

- Balanced design to ensure easy handling and better readability
- Has a reach of 1-5/8" (41mm) maximum hole depth
- Each measuring disc is 9/32" (7mm) diameter and .025" (0.63mm) thick
- Will measure groove widths .050-1.050" (1.27-26.6mm)
- Will measure land widths from 0-1" and 0-25mm

ACCURACY AND LONG-LIFE FEATURES

- Extremely hard and stable one-piece spindle (the heart of our accuracy)
- Hardened, ground, and lapped measuring discs
- Quick and easy adjustment
- This tool is accurate to $\pm .0004"$ or $\pm 0.01\text{mm}$

| .300-2" Range | | | |
|---------------|-------|-------------|------------|
| Cat. No. | EDP | Range | Graduation |
| 458AXR | 67534 | .300-1.300" | .001" |
| 458AXRS* | 67535 | | |
| 458BXR | 67536 | 1-2" | .001" |
| 458BXRS* | 67537 | | |

| 7.6-50mm Range | | | |
|----------------|-------|----------|------------|
| Cat. No. | EDP | Range | Graduation |
| 458MAXR | 67538 | 7.6-33mm | 0.01mm |
| 458MAXRS** | 67539 | | |
| 458MBXR | 67540 | 25-50mm | 0.01mm |
| 458MBXRS** | 67541 | | |

*With 26852-0 Gage Block Standard.

**With 26853-0 Gage Block Standard.



| 260 and 260M Groove Micrometer | | | | | |
|--------------------------------|-------|------------|--------------|-------------|-----------------|
| Cat. No. | EDP | Graduation | Range | Land Widths | Max. Hole Depth |
| 260Z | 67987 | .001" | .050"-1.050" | 0-1.000" | 1-5/8" |
| 260MZ | 67988 | 0.01mm | 1.27-26.27mm | 0-25mm | 41mm |

*Add .050" to 260Z (1.27mm to 260MZ) micrometer reading.

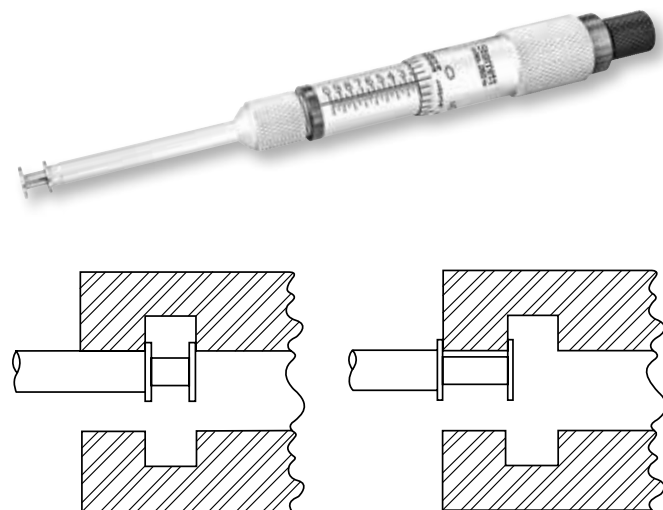

PAPER THICKNESS MICROMETERS

223 PAPER GAGE MICROMETERS

0-11/32"/0-8.75MM

This micrometer is designed for use in paper mills, printing shops, paper warehouses, rubber plants, etc. for accurately, quickly measuring the thickness of paper, cardboard, chipboard, rubber, plastics, and other similar products, up to 11/32" (8.75mm).

223 and 223M Paper Gage Micrometers (0-11/32"/0-8.75mm Range)

| Cat. No. | EDP | Graduation |
|----------|-------|------------|
| 223RL | 50768 | .001" |
| 223MRL | 64336 | 0.01mm |

Case for 223 Paper Gage Micrometers

| Cat. No. | EDP | Description |
|----------|-------|-----------------|
| 921 | 55213 | Protective Case |

READABILITY FEATURES

- Starrett satin chrome finish – no glare – resists rust
- Advanced sleeve design with staggered lines and distinct figures for precise and easy readability
- Convenient decimal equivalents on inch tool

EASE-OF-HANDLING FEATURES

- Balanced frame and thimble design ensure easy handling and readability
- Ring-type knurled lock nut for quick and sure locking
- Combination ratchet and speeder for uniform pressure and quick adjustment
- Anvil and spindle faces are 7/16" (11mm) diameter to prevent compressing the material being measured and to ensure accurate readings
- The floating anvil automatically adjusts itself to any surface condition
- Convenient finger-holding ring is also provided

ACCURACY AND LONG-LIFE FEATURES

- Rigid one-piece frame of drop forged steel
- Extremely hard and stable one-piece spindle (the heart of our accuracy)
- Quick and easy adjustment



223RL

BLADE MICROMETERS

486 BLADE TYPE MICROMETERS WITH NON-ROTATING SPINDLE

0-12"/0-150MM

Here is another special function Starrett micrometer. It is designed for fast and accurate measurements of circular form tools, diameter and depth of narrow grooves, slots, keyways, recesses, and depths between lands and fins.

| 486 Blade Type Micrometers (0-12" Range) | | | |
|---|-------|-----------|------------|
| Cat. No. | EDP | Range | Graduation |
| 486P-1 | 52499 | 0-1" | .001" |
| 486P-2 | 52501 | 1-2" | |
| 486P-3 | 52503 | 2-3" | |
| 486P-4 | 52505 | 3-4" | |
| 486P-5 | 52507 | 4-5" | |
| 486P-6 | 52509 | 5-6" | |
| 486P-7 | 67094 | 6-7" | |
| 486P-8 | 67095 | 7-8" | |
| 486P-9 | 67096 | 8-9" | |
| 486P-10 | 67097 | 9-10" | |
| 486P-11 | 67098 | 10-11" | |
| 486P-12 | 67099 | 11-12" | |
| 486M Blade Type Micrometers (0-150mm Range) | | | |
| Cat. No. | EDP | Range | Graduation |
| 486MP-25 | 64257 | 0-25mm | 0.01mm |
| 486MP-50 | 64258 | 25-50mm | |
| 486MP-75 | 64259 | 50-75mm | |
| 486MP-100 | 64260 | 75-100mm | |
| 486MP-125 | 64261 | 100-125mm | |
| 486MP-150 | 64262 | 125-150mm | |

READABILITY FEATURES

- Starrett satin chrome finish – no glare – resists rust
- Advanced sleeve design with staggered lines and distinct figures for precise and easy readability

EASE-OF-HANDLING FEATURES

- Speeder for quicker adjustment on all sizes
- Non-rotating spindle prevents blade from turning in narrow slots or rolling off shoulder
- The blades are .030" (0.8mm) thick
- Blades will measure to 5/16" (8mm) depths

ACCURACY AND LONG-LIFE FEATURES

- Rigid steel frame ribbed for extra strength on sizes through 6" (150mm)
- Extremely hard and stable one-piece spindle (the heart of our accuracy)
- Quick and easy adjustment

| Cases for 486 and 486M Blade Type Micrometers | | |
|---|-------|------------|
| Cat. No. | EDP | Range |
| 913 | 55400 | 1", 25mm |
| 922 | 55222 | 2", 50mm |
| 952 | 55223 | 3", 75mm |
| 953 | 55224 | 4", 100mm |
| 954 | 55225 | 5", 125mm |
| 930 | 55276 | 6", 150mm |
| 931 | 55277 | 7", 175mm |
| 932 | 55278 | 8", 200mm |
| 933 | 55279 | 9", 225mm |
| 934 | 55280 | 10", 250mm |
| 935 | 55281 | 11", 275mm |
| 436ZZ-13 | 55282 | 12", 300mm |

MICROMETERS



BLADE MICROMETERS

786 ELECTRONIC MICROMETERS WITH NON-ROTATING SPINDLE (WITH OUTPUT)

0-5"/0-125MM

This micrometer is the same as our 486 with electronic readout and the following additional features:

786 Electronic Blade-Type Micrometers with Standard Inch Graduations on Shell and Thimble

| Cat. No. | EDP | Range | | Resolution | |
|----------|-------|-------|------------|------------|---------|
| | | in | Approx. mm | in | mm |
| 786P-1 | 65225 | 0-1 | 0-25.4 | | |
| 786P-2 | 65226 | 1-2 | 25.4-51 | | |
| 786P-3 | 65227 | 2-3 | 51-76 | .00005" | 0.001mm |
| 786P-4 | 65228 | 3-4 | 76-101 | | |
| 786P-5 | 65229 | 4-5 | 101-127 | .0001" | 0.001mm |

786 Electronic Blade-Type Micrometers with Standard Millimeter Graduations on Shell and Thimble

| Cat. No. | EDP | Range | | Resolution | |
|------------|-------|-------------|--------------|------------|---------|
| | | mm | Approx. in | mm | in |
| 786MEP-25 | 66118 | 0 - 25mm | 0-.984" | | |
| 786MEP-50 | 66126 | 25 - 50mm | .984-1.968" | | |
| 786MEP-75 | 66127 | 50 - 75mm | 1.968-2.950" | 0.001mm | .00005" |
| 786MEP-100 | 66128 | 75 - 100mm | 2.950-3.930" | | |
| 786MEP-125 | 66129 | 100 - 125mm | 3.930-4.920" | | |

Cable Information for 786 Electronic Blade-Type Micrometers

| Part No. | EDP | Description |
|----------|-------|--|
| 733SCKB | 69888 | USB cable to PC (In focused window) |
| 733SCU | 69898 | USB cable to computer running SPC Data Collection Software |
| 733SCM | 69893 | Connection to Multiplexer (7612, 7613 or RMS 2704) |
| PT61963 | 66636 | Computer Interface Cable Complete to PC (RS232C) |
| PT61120 | 65446 | One 3-Volt Battery CR2450 |

Attractive, protective case available by ordering 733ZZ and one size larger than the micrometer. Example: For 786P-2, order 733ZZ-3.

READABILITY FEATURES

- Large LCD digital readout is easy to read and reduces errors
- Conventional inch or millimeter graduations standard
- Attractive no-glare black wrinkle finish on the frame
- Starrett no-glare satin chrome finish on thimble and sleeve

ACCURACY AND LONG-LIFE FEATURES

- One 3-volt battery furnished for over a year of normal usage
- Automatic OFF after 30 minutes of nonuse

FULL-FUNCTION ACTION FEATURES

- Instant inch/millimeter conversion
- "ME" millimeter models will turn on in the millimeter mode after installation of a new battery
- Measurement HOLD button
- Ability to zero tool at any position
- Ability to retain and return to the true zero reading of the micrometer
- PRESET button to install any reading at any position
- Ability to install minimum and maximum limits
- RS232 data output port
- Works well with Starrett DataSure® Wireless Data Collection Systems



786P-2

DISC-TYPE MICROMETERS

256 WITH ROTATING OR NON-ROTATING SPINDLES

0-3"/0-75MM

These tools are used to measure the thickness of work sections such as ribs, lands, fins, cutting edges on form tools, and chordal thickness of gear teeth. Because of their large anvil and spindle faces, the 1" and 25mm sizes are also useful for measuring the thickness of sheet materials like paper, cardboard, rubber, and plastics.

| 256 Disc-Type Micrometers (.001" Graduation) | | |
|--|-------|---|
| Cat. No. | EDP | Range |
| 256RL-1 | 51236 | 0-1" |
| 256PN-1 | 56469 | 0-1" |
| 256RL-2 | 55940 | 1-2" |
| 256RL-3 | 55941 | 2-3" |
| 256M Disc-Type Micrometers (0.01mm Graduation) | | |
| Cat. No. | EDP | Range |
| 256MRL-25 | 51238 | 0-25mm |
| 256MPN-25 | 56470 | 0-25mm |
| 256MRL-50 | 55942 | 25-50mm |
| 256MRL-75 | 55943 | 50-75mm |
| Cases for 256 and 256M Disc-Type Micrometers | | |
| Cat. No. | EDP | Description |
| 910 | 55397 | Deluxe case for 1" and 25mm micrometers |
| 912 | 55399 | Deluxe case for 2" and 50mm micrometers |
| 922 | 55222 | Deluxe case for 3" and 75mm micrometers |

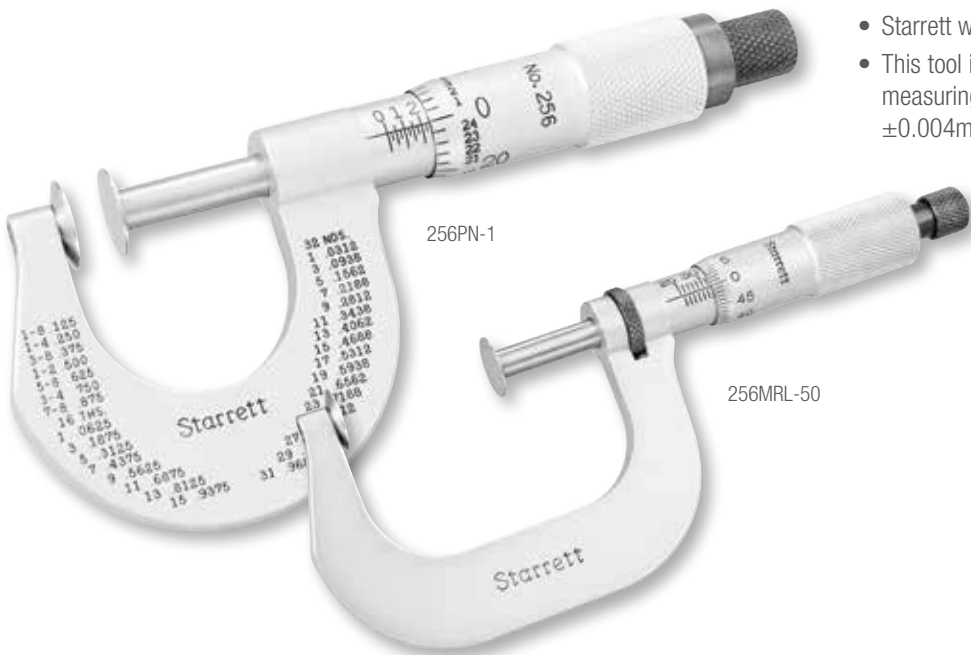

READABILITY FEATURES

- Starrett satin chrome finish – no glare – resists rust
- Advanced sleeve design with staggered lines and distinct figures for precise and easy readability
- Quick-reading figures – every thousandth numbered on inch tools
- Convenient decimal equivalents on 1" and 2" reading tools

EASE-OF-HANDLING FEATURES

- Balanced frame and thimble design ensure easy handling and better readability
- Ring-type knurled lock nut for quick and sure locking
- The combination ratchet and speeder for uniform pressure and quicker adjustment on all sizes
- Gracefully designed tapered frame for use in narrow slots and tight places
- Anvil and spindle discs are 1/2" (12.7mm) diameter tapering to .015" (0.4mm) edge thickness making it possible to enter narrow grooves and recesses
- Available in the 1" and 25mm sizes with rotating or non-rotating spindle

ACCURACY AND LONG-LIFE FEATURES

- Rigid one-piece frame of drop forged steel
- Extremely hard and stable one-piece spindle (the heart of our accuracy)
- Quick and easy adjustment
- Starrett workmanship
- This tool is accurate to $\pm 0.00015"$ or $\pm 0.003mm$ measuring over the whole surface and $\pm 0.0002"$ or $\pm 0.004mm$ measuring on the edges



DISC-TYPE MICROMETERS

756 ELECTRONIC DISC-TYPE MICROMETER WITH ROTATING SPINDLE (WITH OUTPUT)

0-1"/0-25MM

The same as our 256 with an electronic readout and the following additional features and benefits:

756 Electronic Disc-Type Micrometer

| Cat. No. | EDP | Description |
|----------|-------|--|
| 756FL-1 | 64042 | 0-1"/0-25mm range, with standard inch graduations on shell and thimble |

756M Electronic Disc-Type Micrometer

| Cat. No. | EDP | Description |
|------------|-------|--|
| 756MEFL-25 | 66134 | 0-25mm/0-1" range, with standard millimeter graduations on shell and thimble |

Cable Information for 756 and 756M Electronic Disc-Type Micrometers

| Part No. | EDP | Description |
|----------|-------|--|
| 733SCKB | 69888 | USB cable to PC (In focused window) |
| 733SCU | 69898 | USB cable to computer running SPC Data Collection Software |
| 733SCM | 69893 | Connection to Multiplexer (7612, 7613 or RMS 2704) |
| PT61963 | 66636 | Computer Interface Cable Complete to PC (RS232C) |
| PT61120 | 65446 | One 3-Volt Battery CR2450 |

Case for 756 and 756M Electronic Disc-Type Micrometers

| Cat. No. | EDP | Description |
|----------|-------|-----------------|
| 949 | 63874 | Protective case |



756FL-1

READABILITY FEATURES

- Large, right-sized, high-contrast LCD digital readout is easy to read and reduces errors
- Resolution: .00005" and 0.001mm
- Conventional inch or millimeter graduations standard
- Attractive no-glare black wrinkle finish on the frame
- Starrett no-glare satin chrome finish on thimble and sleeve

ACCURACY AND LONG-LIFE FEATURES

- One 3-volt battery furnished for dependable power and over one year's normal usage
- Automatic OFF after 30 minutes of nonuse
- Anvil and spindle discs are 1/2" (12.7mm) diameter tapering to 0.15" (0.4mm) edge thickness making it possible to enter narrow grooves and recesses
- Tool is accurate to ± 0.00015 " or ± 0.003 mm measuring over the whole surface and ± 0.0002 " or ± 0.004 mm measuring on the edge

FULL-FUNCTION ACTION FEATURES

- Instant inch/millimeter conversion
- "ME" millimeter model will turn on in the millimeter mode after installation of a new battery
- Measurement HOLD button
- Ability to zero tool at any position
- Ability to retain and return to the true zero reading of the micrometer
- PRESET button to install any reading at any position
- Ability to install minimum and maximum limits
- RS232 data output port
- Works well with Starrett DataSure® Wireless Data Collection Systems

ROUNDED ANVIL MICROMETERS

576, 577, 211 MICROMETERS

0-1/2"/0-13MM; 0-1"/0-25MM

These three micrometers are all extremely useful for measuring the wall thickness of parts such as solid and split bearings, tubing, sleeves, collars, rings, various cylinders, and also measuring from the inside of a hole to an edge. All three have a rounded anvil which contacts the inside curved surface and a flat spindle for contacting the outside of the work, thus producing single point contact. This permits accurate gaging of curved surface thickness in thousandths of an inch or hundredths of a millimeter.

Rounded anvils are also available on the 222 Sheet Metal Micrometer or by special order.

| 576, 577 and 211 Micrometers (0-1" Range) | | | |
|--|-------|--|------------|
| Cat. No. | EDP | Range | Graduation |
| 576XR | 66441 | 0-1/2" | .001" |
| 577XP | 66443 | 0-1" | |
| 211XP | 66428 | 0-1" | |
| 576M and 577M Micrometers (0-25mm Range) | | | |
| Cat. No. | EDP | Range | Graduation |
| 576MXR | 66442 | 0-13mm | 0.01mm |
| 577MXP | 66444 | 0-25mm | |
| Cases for 576, 576M, 577, 577M and 211 Micrometers | | | |
| Cat. No. | EDP | Description | |
| 910 | 55397 | Attractive protective case for 211 and 577 Micrometers | |
| 921 | 55213 | Attractive protective case for 576 Micrometers | |

Ball Attachment 247 used for rounded anvil effect is also available for other standard micrometers.

CAPACITY

- The 576 can get into holes as small as 5/16 of an inch (8mm) and measure up to 1/2 inch (13mm)
- The 577 can get into holes as small as 3/8 of an inch (9.5mm) and measure up to 1 inch (25mm)
- The 211 can get into holes as small as 5/8 of an inch (16mm) and measure up to 1 inch (25mm)

READABILITY FEATURES

- Starrett satin chrome finish – no glare – resists rust
- Advanced sleeve design with staggered lines and distinct figures for precise and easy readability
- Convenient decimal equivalents on inch tools

EASE-OF-HANDLING FEATURES

- Balanced frame and thimble design ensure easy handling and readability
- Gracefully designed tapered frame for narrow slots and tight places

ACCURACY AND LONG-LIFE FEATURES

- Rigid steel frames
- Extremely hard and stable one-piece spindle (the heart of our accuracy)
- Quick and easy adjustment

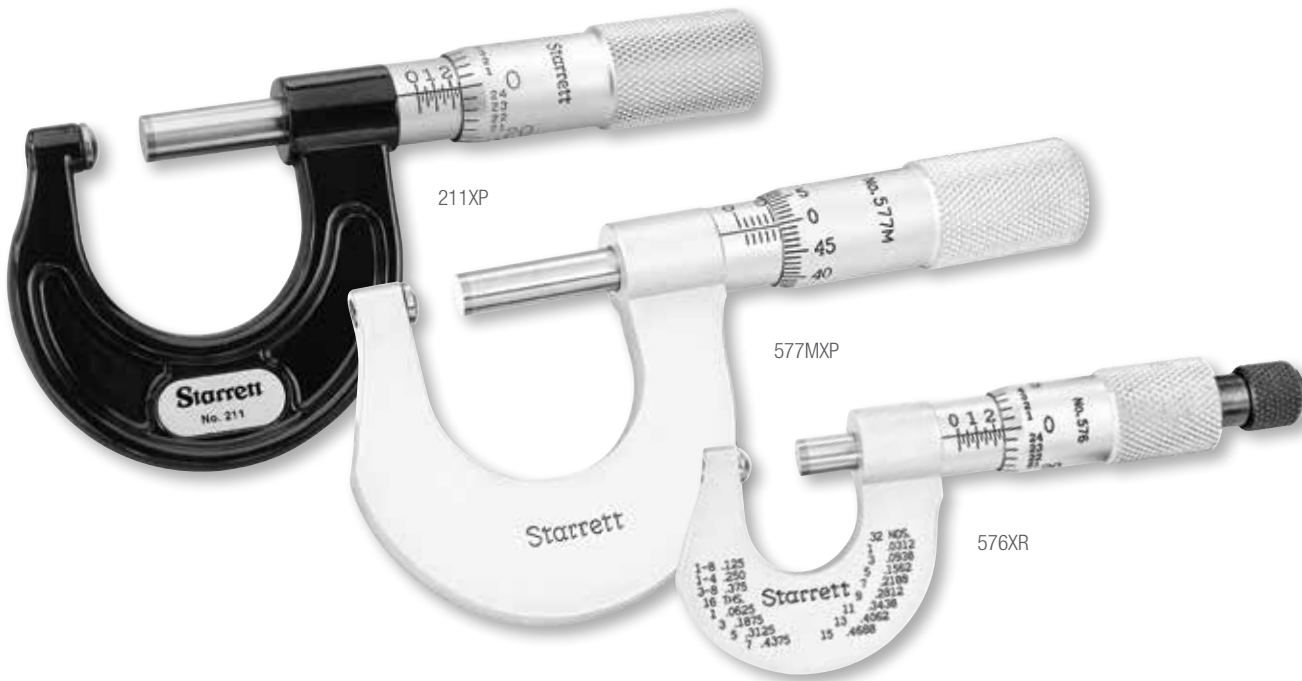

MICROMETERS

788 ELECTRONIC MICROMETERS WITH ROUNDED ANVIL (WITH OUTPUT)

0-1"/0-25MM

This micrometer is similar to our 211, except that it has an electronic readout and the following extra features and benefits:

788 and 788M Electronic Micrometers

| Cat. No. | EDP | Description |
|----------|-------|--|
| 788XFL | 66449 | 0-1"/0-25mm range, with standard inch graduations on shell and thimble |
| 788MEXFL | 66450 | 0-25mm/0-1" range, with standard millimeter graduations on shell and thimble |

Cable Information for 788 Electronic Micrometers

| Part No. | EDP | Description |
|----------|-------|--|
| 733SCKB | 69888 | USB cable to PC (In focused window) |
| 733SCU | 69898 | USB cable to computer running SPC Data Collection Software |
| 733SCM | 69893 | Connection to Multiplexer (7612, 7613 or RMS 2704) |
| PT61963 | 66636 | Computer Interface Cable Complete to PC (RS232C) |
| PT61120 | 65446 | One 3-Volt Battery CR2450 |

Case for 788 and 788M Electronic Micrometers

| Cat. No. | EDP | Description |
|----------|-------|--------------------------|
| 949 | 63874 | Case for 788 Micrometers |

READABILITY FEATURES

- Large, high-contrast LCD digital readout reduces errors
- Resolution: .00005" and 0.001mm
- Conventional inch or millimeter graduations standard
- Attractive no-glare black wrinkle finish on the frame
- Starrett no-glare satin chrome finish on thimble and sleeve

ACCURACY AND LONG-LIFE FEATURES

- One 3-volt battery furnished for dependable power and over one year's normal usage
- Automatic OFF after 30 minutes of nonuse

FULL-FUNCTION ACTION FEATURES

- Instant inch/millimeter conversion
- "ME" millimeter model will turn on in the millimeter mode after installation of a new battery
- Measurement HOLD button
- Ability to zero tool at any position
- Ability to retain and return to the true zero reading of the micrometer
- PRESET button to install any reading at any position
- Ability to install minimum and maximum limits
- RS232 data output port
- Works well with Starrett DataSure® Wireless Data Collection Systems



788XFL

MICROMETERS

205 STEEL MILL MICROMETER

0-1"

This micrometer is specially designed for gaging hot metal sheet in steel mills and has many features for safer, faster, and more accurate measurements. Micrometer has rugged construction throughout, and is attached to a convenient wooden handle, correctly shaped for a firm grip. Allows measurements to be made while the micrometer can be comfortably held at a safe distance from the hot metal.

READABILITY FEATURES

- Starrett satin chrome finish – no glare – resists rust
- Advanced sleeve design with staggered lines and distinct figures for precise and easy readability
- Quick-reading figures – every thousandth numbered on inch tools
- Convenient decimal equivalents on inch tools
- Extra long bevel on thimble with heavy cut graduations

EASE-OF-HANDLING FEATURES

- Both spindle and anvil are beveled to easily slide onto the work
- Large, reversible wing lock nut is easy to lock or release, even when wearing heavy gloves
- Rugged frame construction and heavy duty spindle of .270" diameter

ACCURACY AND LONG-LIFE FEATURES

- Rigid one-piece frame of drop forged steel
- Extremely hard and stable one-piece spindle (the heart of our accuracy)
- Quick and easy adjustment by either the anvil or by a simple sleeve adjustment

| 205 Steel Mill Micrometer | | | | |
|---------------------------|-------|-------|------------|-----------------------|
| Cat. No. | EDP | Range | Graduation | Description |
| 205HL | 50730 | 0-1" | .001" | Lock nut, with handle |



247 MICROMETER BALL ATTACHMENTS

INCH/MM

Outside micrometers and micrometer heads having spindle sizes listed below can be instantly converted for measuring wall thickness of tubing, split and full bearings, sleeves and other parts with rounded surfaces by means of the 247 Ball Attachment.

FEATURES

- Easily applied by snapping on to end of either anvil or spindle, thus permitting two attachments to be used together
- Balls are hardened, measure .200" and 5mm in diameter, and move freely in the retainer, insuring positive contact with anvil and spindle
- The diameters, .200" or 5mm, of each ball used must be subtracted from the micrometer reading
- All metal construction

247 Micrometer Ball Attachments, .200" Diameter Balls

| Cat. No. | EDP | Description |
|----------|-------|--|
| 247A | 51174 | For 2, 226 (old style), 230 and 577 Micrometers and 263 Micrometer Heads, .235" diameter Anvil and Spindle |
| 247B | 51175 | For 224A, 224AA and 436 Micrometers, .270" diameter anvil and spindle |
| 247C | 51176 | For 232 Micrometers and 463 Micrometer Heads, .200" diameter anvil and spindle |
| 247D | 51177 | For 216, 226 (new style), 231, 436.1, 733, 795, 796, 3732, 1212 and 1230 Micrometers, .250" diameter anvil and spindle |
| 247E | 51178 | For 224B through J, 238, 239, 436 Micrometers and 663 Micrometer Heads, .300" diameter anvil and spindle |

247M Micrometer Ball Attachments, 5mm Diameter Balls

| Cat. No. | EDP | Description |
|----------|-------|---|
| 247MA | 51179 | For 2M and 230M Micrometers and 263M Micrometer Heads, 6mm diameter anvil and spindle |
| 247MB | 51180 | For 436M Micrometers, 6.8mm diameter anvil and spindle |
| 247MD | 56691 | For 216M and 436.1M Micrometers, 6.35mm diameter anvil and spindle |
| 247ME | 56692 | For 224MB through J, 238M, 436M Micrometers and 663M Micrometer Heads, 7.6mm diameter anvil and spindle |



SCREW THREAD MICROMETERS

575, 585 MICROMETERS FOR MEASURING PITCH DIAMETER

0-1"/0-25MM; 1-2"/25-50MM

These micrometers have a pointed spindle and a double V-anvil, both shaped to contact the screw thread as shown in the drawing. The micrometer reading therefore gives the pitch diameter.*

575 and 585 Screw Thread Micrometers (.001" Graduation)

| Cat. No. | EDP | Range, Threads Per inch | Capacity, Pitch Diameter |
|----------|-------|-------------------------|--------------------------|
| 575AP | 56159 | 7-9 | 0-1" |
| 575BP | 56160 | 10-13 | |
| 575CP | 56161 | 14-18 | |
| 575DP | 56162 | 20-24 | |
| 575EP | 56163 | 28-30 | |
| 575FP | 56164 | 32-40 | |
| 585AP | 56165 | 4 1/2 - 6 | 1-2" |
| 585BP | 56166 | 7-9 | |
| 585CP | 56167 | 10-13 | |
| 585DP | 56168 | 14-18 | |
| 585EP | 56169 | 20-24 | |
| 585FP | 56170 | 28-30 | |

575M and 585M Screw Thread Micrometers (0.01mm Graduation)

| Cat. No. | EDP | Range, Pitch in mm | Capacity, Pitch Diameter |
|----------|-------|--------------------|--------------------------|
| 575MAP | 56321 | 3-4 | 0-25mm |
| 575MBP | 56322 | 2-2.5 | |
| 575MCP | 56323 | 1.25-1.75 | |
| 575MDP | 56324 | 0.75-1 | |
| 575MEP | 56325 | 0.5-0.7 | |
| 575MFP | 56326 | 0.35-0.45 | |
| 585MAP | 56327 | 4.5-6 | 25-50mm |
| 585MBP | 56328 | 3-4 | |
| 585MCP | 56329 | 2-2.5 | |
| 585MDP | 56330 | 1.25-1.75 | |

Cases

| Cat. No. | EDP | Description |
|----------|-------|------------------------------------|
| 910 | 55397 | Attractive protective case for 575 |
| 912 | 55399 | Attractive protective case for 585 |

Swivel anvil available on special order – also in capacities over 2" (50mm).

575 sent in fitted case.

585 packed one in a box without case.

READABILITY FEATURES

- Starrett satin chrome finish – no glare – resists rust
- Advanced sleeve design with staggered lines and distinct figures for precise and easy readability
- Decimal equivalents on inch tools

EASE-OF-HANDLING FEATURES

- Balanced frame and thimble design for easy handling and better readability
- Gracefully designed tapered frame for use in narrow slots and tight places
- Furnished with fixed (non-rotating) anvil, but swivel anvils available on special order
- Available in capacity over 2" or 50mm (special order)

ACCURACY AND LONG-LIFE FEATURES

- One-piece frame of drop forged steel
- Extremely hard and stable one-piece spindle (the heart of our accuracy)
- Quick and easy adjustment
- Design allows 50% to 75% contact with the thread to be measured, thereby insuring contact with the pitch diameter at all times
- Design also ensures against contact with the root area of the thread
- Tools are accurate to $\pm .0002"$ or 0.004mm

575 AND 585 – INCH

For measuring American Unified National series and Unified J series screw threads. 585 micrometers come with a one-inch standard at no extra cost.

575M AND 585M – METRIC

For measuring I.S.O. metric and MJ screw threads. 585M micrometers come with a 25mm standard at no extra cost.

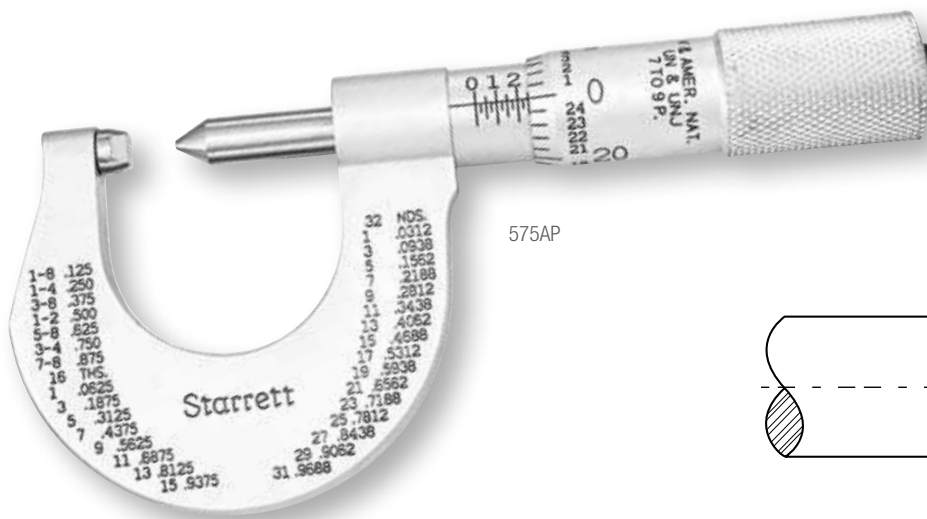

575AP

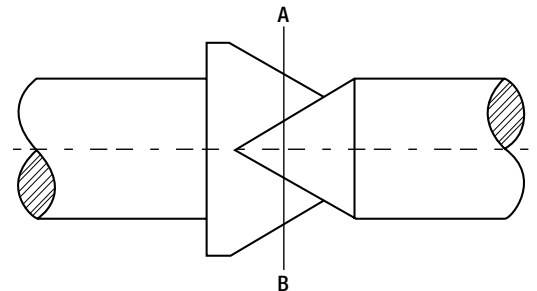

* MEASURING TIP: These tools are accurate for general purposes, especially if set to a thread plug gage of the size to be measured.

With the 575AP 0-1", pitch diameter is read directly in inches, since the line AB corresponds to the 0 reading.

POINT MICROMETERS

210 SCREW THREAD COMPARATOR MICROMETERS

0-7/8"/0-22MM

This micrometer is ideal for quick comparisons of thread accuracy in screw cutting operations, measuring in small grooves or recesses where regular micrometers cannot be used, and for many other applications.

NOTE: Does not measure pitch diameter. For such measurements, 575 or 585 Thread Micrometers are recommended.

READABILITY FEATURES

- Starrett satin chrome finish – no glare – resists rust
- Advanced sleeve design with staggered lines and distinct figures for precise and easy readability
- Convenient decimal equivalents on inch reading tools

EASE-OF-HANDLING FEATURES

- Balanced frame and thimble design ensure easy handling and better readability
- Gracefully designed tapered frame for narrow slots and tight places

ACCURACY AND LONG-LIFE FEATURES

- Rigid steel frame
- Extremely hard and stable one-piece spindle (the heart of our accuracy)
- The 210 has 60° conical anvil and spindle faces with 1/64" (0.4mm) flats on the ends of the points
- Quick and easy adjustment

760 ELECTRONIC SCREW THREAD COMPARATOR MICROMETER (WITH OUTPUT)

0-1"/0-25MM

Same features as our 210 with electronic readout and the following additional features and benefits:

READABILITY FEATURES

- Large LCD digital readout is easy to read and reduces errors
- Resolution: .00005" and 0.001mm
- Conventional inch or millimeter graduations standard
- Attractive no-glare black wrinkle finish on the frame
- Starrett no-glare satin chrome finish on thimble and sleeve

ACCURACY AND LONG-LIFE FEATURES

- One 3-volt battery furnished for over a year of normal usage
- Automatic OFF after 30 minutes of nonuse

FULL-FUNCTION ACTION FEATURES

- Instant inch/millimeter conversion
- "ME" millimeter model turns on in millimeter mode after battery installation
- Measurement HOLD button
- Zero tool at any position and return to true zero reading
- PRESET button to install any reading at any position
- Ability to install minimum and maximum limits
- RS232 data output port
- Works well with Starrett DataSure® Wireless Data Collection Systems

210 and 210M Screw Thread Comparator Micrometers (0-7/8" Range)

| Cat. No. | EDP | Range | Graduation |
|----------|-------|--------|------------|
| 210AP | 50731 | 0-7/8" | .001" |
| 210MAP | 64334 | 0-22mm | 0.01mm |

Case for 210 and 210M Screw Thread Comparator Micrometers

| Cat. No. | EDP | Description |
|----------|-------|----------------------------|
| 910 | 55397 | Attractive protective case |

760 and 760M Electronic Screw Thread Comparator Micrometer

| Cat. No. | EDP | Description |
|----------|-------|---|
| 760FL | 64051 | 0-1"/0-25mm range, standard inch graduations on shell and thimble |
| 760MEFL | 66135 | 0-25mm/0-1" range, standard millimeter graduations on shell and thimble |

Case for 760 and 760M Electronic Screw Thread Comparator Micrometers

| Cat. No. | EDP | Description |
|----------|-------|----------------------------|
| 731ZZ-2 | 65163 | Attractive protective case |

Cable Information for 760 and 760M Electronic Screw Thread Comparator Micrometers

| Part No. | EDP | Description |
|----------|-------|--|
| 733SCKB | 69888 | USB cable to PC (In focused window) |
| 733SCU | 69898 | USB cable to computer running SPC Data Collection Software |
| 733SCM | 69893 | Connection to Multiplexer (7612, 7613 or RMS 2704) |
| PT61963 | 66636 | Computer Interface Cable Complete to PC (RS232C) |
| PT61120 | 65446 | One 3-Volt Battery CR2450 |



MICROMETERS

483, 485 V-ANVIL MICROMETERS

.093-2"/2-25MM | .078-1"

Used to check out-of-roundness from centerless grinding or other machining operations. Also used for measuring odd fluted taps, milling cutters, and reamers.

READABILITY FEATURES

- Direct measuring of three and five-fluted tools
- Starrett satin chrome finish – no glare – resists rust
- Advanced sleeve design for precise and easy readability
- Quick-reading figures – every thousandth numbered on inch tools

EASE-OF-HANDLING FEATURES

- Balanced frame and thimble design ensure easy handling and readability
- Ring-type knurled lock nut for quick and sure locking
- Combination ratchet and speeder for uniform pressure and quick adjustment

ACCURACY AND LONG-LIFE FEATURES

- Rigid one-piece frame of drop forged steel
- Extremely hard and stable one-piece spindle (the heart of our accuracy)
- Carbide facing on spindle and anvils for extra long wear
- Quick and easy adjustment

483, 483M and 485 V-Anvil Micrometers

| Cat. No. | EDP | Range | Graduation | No. of Flutes it will Measure |
|------------|-------|---------|------------|-------------------------------|
| T483XRL-1 | 52491 | .093-1" | .0001" | 3 |
| T483XRL-2 | 52494 | 1-2" | .0001" | 3 |
| T485XRL | 52497 | .078-1" | .0001" | 5 |
| 483MXRL-25 | 56046 | 2-25mm | 0.01mm | 3 |
| 485MXRL | 56047 | | | 5 |

Cases for 483, 483M and 485 V-Anvil Micrometers

| Cat. No. | EDP | Description |
|----------|-------|--|
| 939 | 55331 | Attractive protective case for 1" and 25mm sizes |
| 483ZZ-2 | 55332 | Attractive protective case for 2" size |



225 WIRE MICROMETERS

0-.400"/0-10MM

This is another regularly offered special function Starrett micrometer designed to measure diameter of wire up to .400" (10mm).

READABILITY FEATURES

- Starrett satin chrome finish – no glare – resists rust
- Advanced sleeve design with staggered lines and distinct figures for precise and easy readability
- Quick-reading figures – every thousandth numbered on inch tools

EASE-OF-HANDLING FEATURES

- Smooth friction thimble for uniform pressure
- Hex body which stops the micrometer from rolling over when placed on a flat surface
- The throat is flat to support the wire when measuring
- The anvil and spindle extend below the flat surface

ACCURACY AND LONG-LIFE FEATURES

- Extremely hard and stable one-piece spindle (the heart of our accuracy)
- Quick and easy adjustment

225 Wire Micrometers (0-.400" Range)

| Cat. No. | EDP | Graduation |
|----------|-------|------------|
| T225F | 50814 | .0001" |

225M Wire Micrometers (0-10mm Range)

| Cat. No. | EDP | Graduation |
|----------|-------|------------|
| V225MF | 64255 | 0.001mm |



T225F



MICROMETERS

207, 208 STAINLESS STEEL CAN SEAM MICROMETERS

207 and 208 Can Seam Micrometers are made of stainless steel and designed to measure the thickness and depth of can seams.

The 207 Micrometer is used to measure the seam at outside bottom edge of dome on top of aerosol cans. The 208 Micrometer is used to measure thickness of seam at top and bottom of flat-topped cans. The 208D Micrometer is used to measure thickness and depth of all standard can seams.

READABILITY FEATURES

- Satin finish stainless steel – no glare – rust and stain resistant
- Advanced sleeve design with staggered lines and distinct figures for precise and easy readability
- Quick-reading figures – every thousandth numbered on inch tools

EASE-OF-HANDLING FEATURES

- The 207 has a snub nose which permits measuring aerosol type cans

ACCURACY AND LONG-LIFE FEATURES

- Extremely hard and stable one-piece spindle (the heart of our accuracy)
- Quick and easy adjustment

| 207 and 208 Stainless Steel Can Seam Micrometers (0-.375" Range) | | | |
|--|-------|------------|-------------------------------|
| Cat. No. | EDP | Graduation | Description |
| 207Z | 56173 | | Snub nose for aerosol cans |
| 208Z | 56175 | .001" | Without depth gage |
| 208DZ | 56176 | | With depth gage (.200" range) |
| 207M and 208M Stainless Steel Can Seam Micrometers (0-9.5mm Range) | | | |
| Cat. No. | EDP | Graduation | Description |
| 207MZ | 64337 | | Snub nose for aerosol cans |
| 208MZ | 64338 | 0.01mm | Without depth gage |
| 208MDZ | 63191 | | With depth fage (5mm range) |

Depth range on 208D is .200". Depth range on 208MD is 5mm.



209 CAN CURL MICROMETERS

0-.500"/0-12.5MM

The 209 features a special rest foot and finger ring for consistent measurement of the curl thickness on aerosol cans with 1" (25mm) diameter domed tops.

READABILITY FEATURES

- Starrett satin chrome finish – no glare – resists rust
- Advanced sleeve design with staggered lines and distinct figures for precise and easy readability
- Quick-reading figures – every thousandth numbered on inch tools
- Convenient decimal equivalents on inch tools

EASE-OF-HANDLING FEATURES

- Balanced frame and thimble design ensure easy handling and better readability
- Ring-type knurled lock nut for quick and sure locking
- Combination ratchet and speeder for uniform pressure and quicker adjustment
- Finger ring for ease of measuring

ACCURACY AND LONG-LIFE FEATURES

- Special rest foot to locate the tool for higher repeatability
- Extremely hard and stable one-piece spindle (the heart of our accuracy)
- Quick and easy adjustment

| 209 Can Curl Micrometers (0-.500" Range) | | |
|--|-------|------------|
| Cat. No. | EDP | Graduation |
| 209RL | 56473 | .001" |
| 209M Can Curl Micrometers (0-12.5mm Range) | | |
| Cat. No. | EDP | Graduation |
| 209MRL | 64364 | 0.01mm |

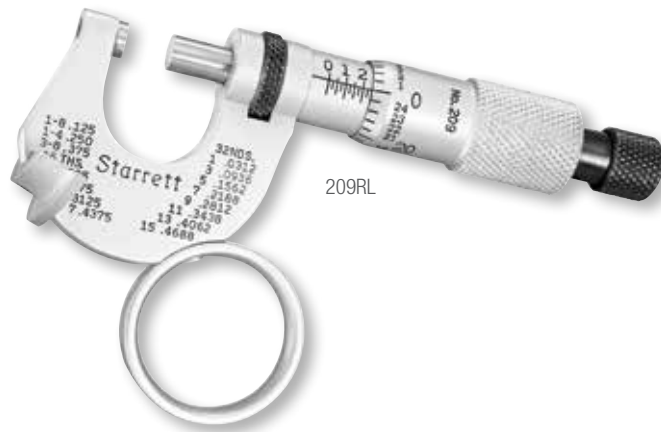

MICROMETERS

228 Hub Micrometer

0-1"

The 228 Hub Micrometer is an ideal tool for precision measuring of hub thickness, for insertion through small holes to measure thickness, and for many other related uses. Micrometer has a specially designed shallow frame which makes it possible to easily pass through a 3/4" (19mm) hole.

| 228 Hub Micrometer (0-1" Range) | | |
|---------------------------------|-------|------------------------------------|
| Cat. No. | EDP | Graduation |
| 228XRL | 50921 | .001" |
| Case | | |
| Cat. No. | EDP | Description |
| 228ZZ | 55228 | Deluxe case for 228 Hub Micrometer |

READABILITY FEATURES

- Starrett satin chrome finish – no glare – resists rust
- Advanced sleeve design with staggered lines and distinct figures for precise and easy readability
- Quick-reading figures – every thousandth numbered on inch tools

EASE-OF-HANDLING FEATURES

- Balanced frame and thimble design ensure easy handling and better readability
- Ring-type knurled lock nut for quick and sure locking
- Combination ratchet and speeder for uniform pressure and quicker adjustment

ACCURACY AND LONG-LIFE FEATURES

- Rigid one-piece frame of drop forged steel
- Extremely hard and stable one-piece spindle (the heart of our accuracy)
- Quick and easy adjustment



228XRL

MICROMETER HEADS

The following pages show the full line of Starrett standard micrometer heads that have been designed and developed over the years working with the needs of our customers. The micrometer heads are invaluable for use on electronic equipment, machine tools, fixtures, special gaging and other equipment where precise movement and adjustment are required.

Dimensional specifications are available upon request.

Special features are described with each tool, but all of these tools have these features that benefit the user:

- Starrett satin chrome finish – no glare – resists rust on all reading surfaces
- Advanced sleeve design with staggered lines and distinct figures for precise and easy readability
- Quick-reading figures on all inch reading tools
- Extremely hard and stable one-piece spindle (the heart of our accuracy and long life)
- Micro-lapped measuring face for flatness and squareness
- Quick and easy adjustment

SPECIAL HEADS

In addition to standard micrometer heads, Starrett has also designed and manufactured many special types of micrometer heads for widely diversified applications requiring micrometer accuracy in settings and adjustments. These special heads are designed to exact specifications for specialized usage with wave meters and other equipment in the electronics industry, machine tools, fixtures, special gages, tools, and all special mountings. They can be furnished to suit your particular requirements in a wide choice of sizes, range and graduations.

We design and build to your special need, so if you don't see what you want, please ask for it.

For quotations or recommendations, write:
The L.S. Starrett Co.
Special Order Department
121 Crescent Street
Athol, MA 01331

MICROMETER HEADS

261L MICROMETER HEADS WITH NON-ROTATING SPINDLES

0-1/2"/0-13MM

Because the spindle does not rotate, these tools are useful in driving positioning tables directly without an intermediate connecting device. They are also useful in gaging jobs where scratches on the work surface cannot be tolerated or where there is risk of distortion when spindle meets work – as in measuring soft or elastic materials. Spindle wear is also reduced since there is no rotational friction as its face contacts the work.

- Ring-type lock nut for quick and sure locking at any setting
- A speeder for quicker adjustment – this is not a ratchet stop. The tool is dependent on your own "feel"

261L Micrometer Heads (0-1/2" Range)

| Cat. No. | EDP | Graduation | Description |
|----------|-------|------------|-------------------|
| 261L | 55944 | .001" | Speeder, lock nut |

261ML Micrometer Heads (0-13mm Range)

| Cat. No. | EDP | Graduation | Description |
|----------|-------|------------|---|
| 261ML* | 64346 | 0.01mm | Specify clamping diameter (9.5mm or 10mm) |

*9.5mm clamping diameter sent unless otherwise specified.



261L

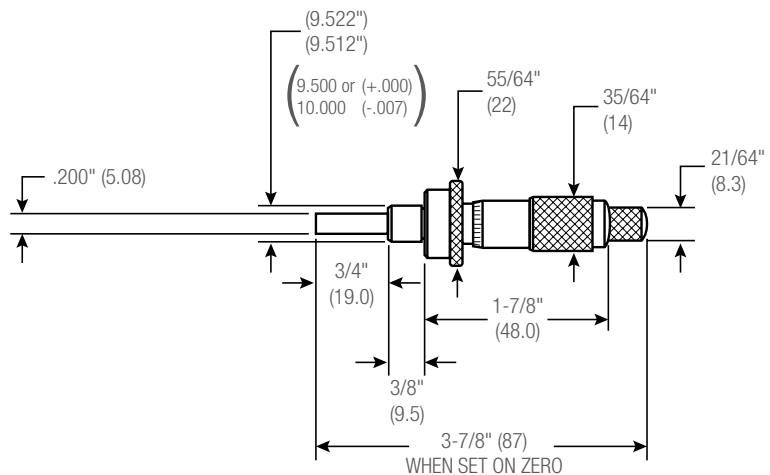

261L (0-1/2") and 261ML (0-13mm) dimensions



MICROMETER HEADS

262 MICROMETER HEADS WITH NON-ROTATING SPINDLES

0-1"/0-25MM

Because the spindle does not rotate, this tool is useful in driving positioning tables directly without an intermediate connecting device. It is also useful in gaging jobs where scratches on the work surface cannot be tolerated, or where there is risk of distortion when spindle meets work – as in measuring soft or elastic materials. Spindle wear is also reduced, since there is no rotational friction when its face contacts the work.

- Ring-type lock nut for quick and sure locking at any setting
- Available with or without the combination ratchet and speeder for uniform pressure and quicker adjustment

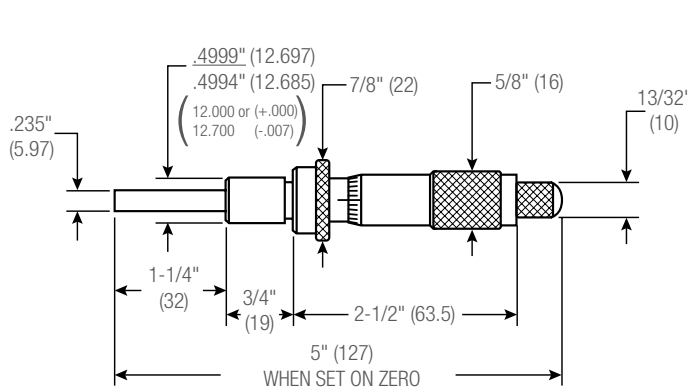

262L (0-1") and 262ML (0-25mm) dimensions

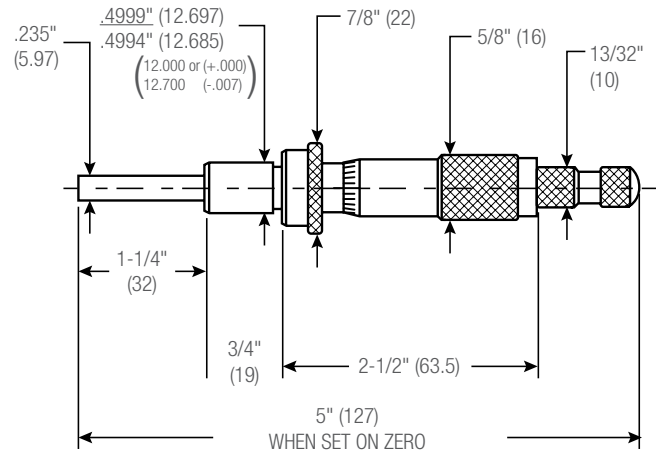

262RL (0-1") and 262MRL (0-25mm) dimensions

| 262 Micrometer Heads (0-1" Range) | | |
|--------------------------------------|-------|------------|
| Cat. No. | EDP | Graduation |
| 262L | 55945 | .001" |
| 262RL | 55946 | |
| 262M Micrometer Heads (0-25mm Range) | | |
| Cat. No. | EDP | Graduation |
| 262ML* | 64347 | 0.01mm |
| 262MRL* | 65051 | |

0-25mm models specify clamping diameter 12mm or 12.7mm. 12.7mm sent unless otherwise ordered.



262L

MICROMETER HEADS

762 ELECTRONIC MICROMETER HEADS WITH ROTATING OR NON-ROTATING SPINDLES (WITH OUTPUT)

0-2"/0-50MM

READABILITY FEATURES

- Large digital readout is easy to read, reducing errors
- Conventional inch or millimeter graduations standard
- Attractive black wrinkle finish on frame
- Starrett no-glare satin chrome finish on thimble and sleeve

EASE-OF-HANDLING FEATURES

- Ring-type knurled lock nut
- Smooth friction thimble for uniform pressure on regular heads and combination ratchet and speeder on non-rotating heads

ACCURACY AND LONG-LIFE FEATURES

- Extremely hard and stable one-piece spindle (the heart of our accuracy)
- One 3-volt battery furnished for over a year of normal usage
- Auto OFF after 30 minutes of nonuse

FULL-FUNCTION ACTION FEATURES

- Inch/millimeter conversion
- "ME" millimeter models turn on in millimeter mode after battery installation
- Measurement HOLD button
- Ability to zero tool at any position
- Ability to retain and return to the true zero reading of the micrometer
- PRESET button to install any reading at any position
- RS232 data output port
- Works well with Starrett DataSure® Wireless Data Collection Systems

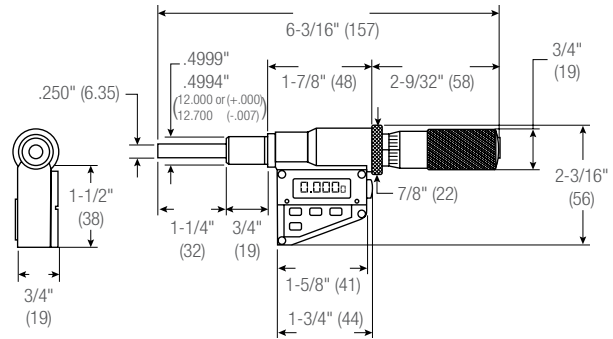

0-1" (0-25mm) dimensions

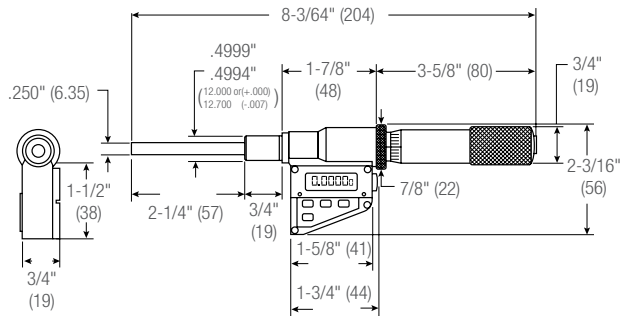

0-2" (0-50mm) dimensions



| 762 Micrometer Specifications | | | |
|-------------------------------|-------|-----------------|-----------------|
| Resolution | | Accuracy | |
| in | mm | in | mm |
| .00005 | 0.001 | ±.0001 per inch | ±0.003 per 25mm |

762 Electronic Micrometer Heads with Standard Inch Graduations on Shell and Thimble

| Cat. No. | EDP | Range | Description* |
|----------|-------|-------------|--|
| 762XFL | 65058 | 0-1"/0-25mm | Friction thimble, lock nut, carbide face |
| 762NXRL | 65060 | | Ratchet stop, lock nut, carbide face, non-rotating spindle |
| 762XFL-2 | 65062 | 0-2"/0-50mm | Friction thimble, lock nut, carbide face |

762M Electronic Micrometer Heads with Standard Millimeter Graduations on Shell and Thimble

| Cat. No. | EDP | Range | Description* |
|-------------|-------|-------------|--|
| 762MEXFL-25 | 66077 | 0-25mm/0-1" | Friction thimble, lock nut, carbide face |
| 762MEXFL-50 | 66137 | 0-50mm/0-2" | Friction thimble, lock nut, carbide face |

Cable Information for 762 and 762M Electronic Micrometer Heads

| Part No. | EDP | Description |
|----------|-------|--|
| 733SCKB | 69888 | USB cable to PC (In focused window) |
| 733SCU | 69898 | USB cable to computer running SPC Data Collection Software |
| 733SCM | 69893 | Connection to Multiplexer (7612, 7613 or RMS 2704) |
| PT61963 | 66636 | Computer Interface Cable Complete to PC (RS232C) |
| PT61120 | 65446 | One 3-Volt Battery CR2450 |

*1/2" (12.7mm) clamping diameter sent unless otherwise specified.



MICROMETER HEADS

464P MICROMETER HEADS

0-1/4"

460A MICROMETER HEADS

0-1/4"/0-6.5MM

460B MICROMETER HEADS

0-1/2"/0-13MM

These are plain micrometer heads with no lock nut or ratchet.

| 464P, 460A, 460MA, 460B and 460MB Micrometer Heads | | | |
|--|-------|---------|------------|
| Cat. No. | EDP | Range | Graduation |
| 464P | 56657 | 0-1/4" | .001" |
| 460A | 64444 | 0-1/4" | .001" |
| 460MA | 64445 | 0-6.5mm | 0.01mm |
| 460B | 64446 | 0-1/2" | .001" |
| 460MB | 64447 | 0-13mm | 0.01mm |



464P

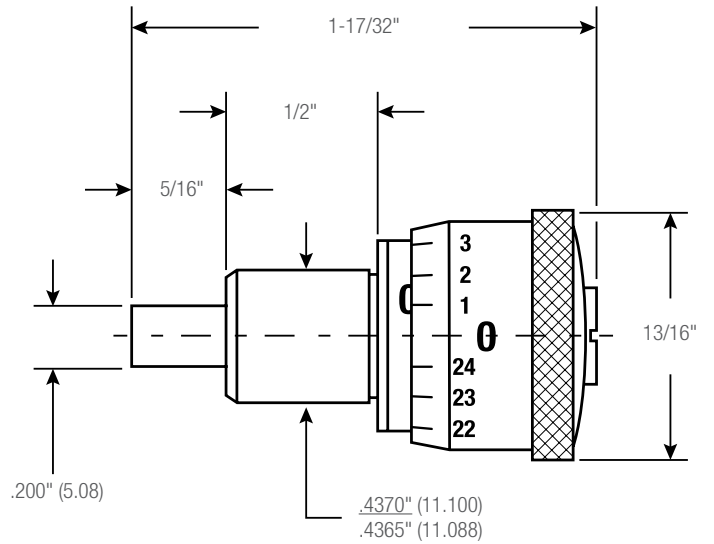

464P (0-1/4") dimensions



460A



460B

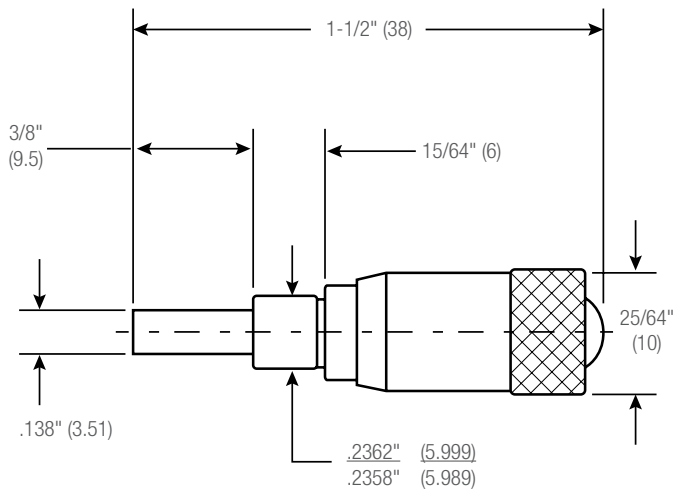

460A (0-1/4") and 460MA (0-6.5mm) dimensions

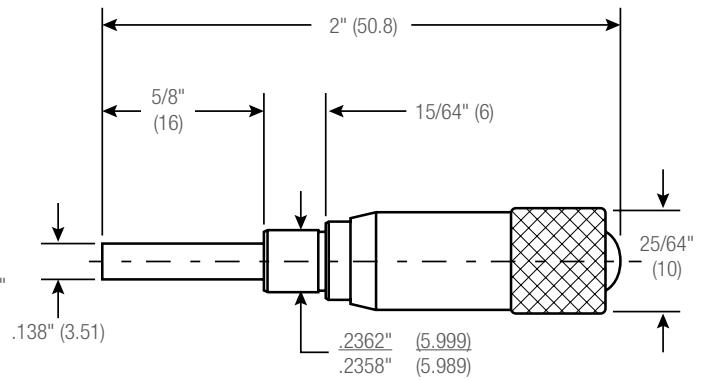

460B (0-1/2") and 460MB (0-13mm) dimensions



MICROMETER HEADS

463 MICROMETER HEADS

0-1/2"/0-13MM

1463 STAINLESS STEEL MICROMETER HEADS

0-1/2"/0-13MM

The 463 and 1463 Micrometer head are exactly the same, except that the 1463 is made from rust-resistant stainless steel. The reading surfaces are satin finished stainless steel for easy readability. Heads are available with the features below:

- Either combination ratchet and speeder for uniform pressure and quicker adjustment, or plain micrometer heads that depend on your own feel
- Ring-type lock nut for quick and sure locking at any setting
- Reverse reading, if needed
- Plain or carbide spindle faces

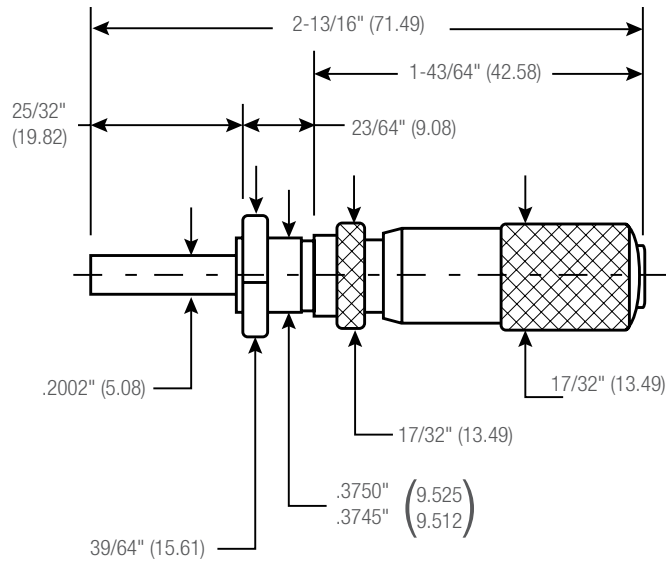

463L-38TN (0-1/2") dimensions

463 and 1463 Micrometer Heads

| Cat. No. | EDP | Range | Graduation |
|-----------|-------|--------|------------|
| 463P | 52440 | 0-1/2" | .001" |
| 463P-38TN | 67112 | | |
| 463L | 52442 | | |
| 463XL | 52451 | | |
| 463L-38TN | 67113 | | |
| 463RL | 52443 | | |
| 463XRL | 64687 | | |
| RV463RL | 57073 | 0-1/2" | .0001" |
| RV463XRL | 64688 | | |
| T463P | 52446 | | |
| T463L | 52448 | | |
| T463XL | 64689 | | |
| T463RL | 52449 | | |
| T463XRL | 65052 | | |
| 463MP | 52444 | 0-13mm | 0.01mm |
| 463MRL | 52452 | | |
| 463MXRL | 64691 | | |
| V463MRL | 65053 | 0-13mm | 0.002mm |
| RV463MRL | 60845 | | |
| 1463RL | 53207 | | |
| T1463RL | 53209 | | |
| V1463MRL | 64344 | 0-13mm | 0.002mm |

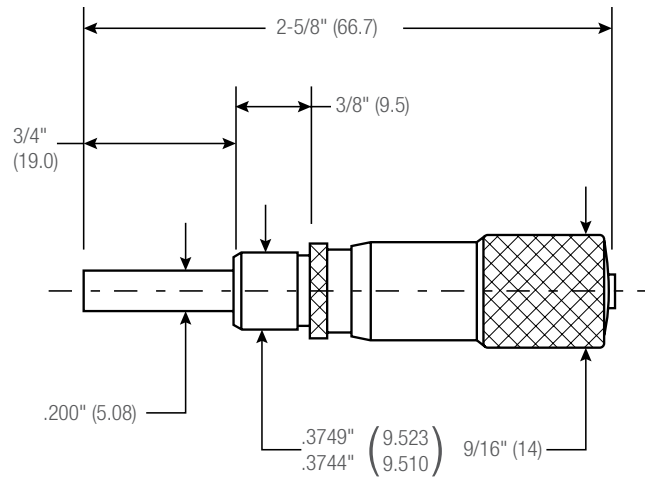

463P (0-1/2") and 463MP (0-13mm) dimensions



463RL

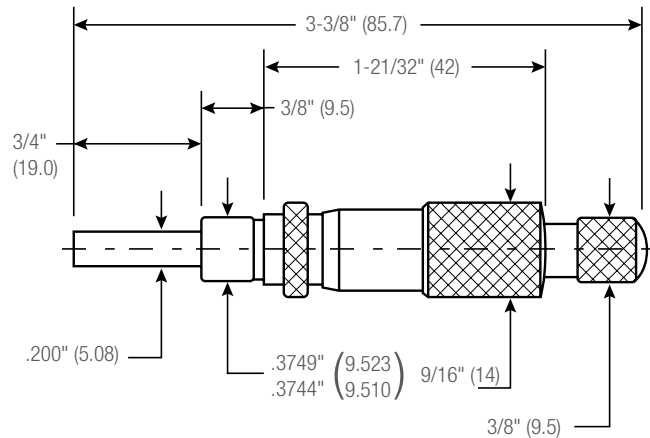

463RL (0-1/2") and 463MRL (0-13mm) dimensions



MICROMETER HEADS

263 AND 1263 MICROMETER HEADS

0-1"/0-25MM

- Reading surfaces satin-finished for easy readability
- No-glare, satin chrome finish on the 263, rust-resistant, stainless steel on the 1263
- Available with reverse reading, if needed
- Ring-type knurled lock nut for quick and sure locking
- Choice of smooth friction thimble for uniform pressure, combination ratchet and speeder for uniform pressure and quicker adjustment, or a plain micrometer head that depends on your own "feel"
- Spindle face available plain or with carbide
- Furnished with 1/2" (12.7mm) or 3/8" (9.5mm) diameter clamping surface

263 and 263M Micrometer Heads

| Cat. No. | EDP | Range | Graduation | | | | |
|-----------|-------|-------|------------|--------|--------|--------|---------|
| 263P | 51251 | 0-1" | .001" | | | | |
| 263P-38 | 67108 | | | | | | |
| 263P-38TN | 67110 | | | | | | |
| 263L | 51253 | | | | | | |
| 263XL | 51265 | | | | | | |
| 263L-38 | 67109 | | | | | | |
| 263L-38TN | 67111 | | | | | | |
| 263RL | 51254 | | | | | | |
| 263FL | 51256 | | | | | | |
| RV263RL | 57071 | | | | | | |
| T263P | 51258 | 0-1" | .0001" | | | | |
| T263L | 51260 | | | | | | |
| T263XL | 65054 | | | | | | |
| T263RL | 51261 | | | | | | |
| 263MP* | 51275 | | | 0-25mm | 0.01mm | | |
| 263ML* | 51276 | | | | | | |
| 263MRL* | 51257 | | | | | | |
| 263MXL* | 65055 | | | | | | |
| V263MRL* | 55962 | | | | | 0-25mm | 0.001mm |
| RV263MRL* | 64948 | | | | | | |
| V263MXRL* | 65056 | | | | | | |

1263 and 1263M Stainless Steel Micrometer Heads

| Cat. No. | EDP | Range | Graduation |
|-----------|-------|--------|------------|
| 1263L | 53200 | 0-1" | .001" |
| 1263RL | 53201 | 0-1" | .001" |
| T1263RL | 53203 | 0-1" | .0001" |
| V1263MRL* | 64345 | 0-25mm | 0.001mm |

*0-25mm models specify clamping diameter 12 or 12.7mm. 12.7mm sent unless otherwise ordered.

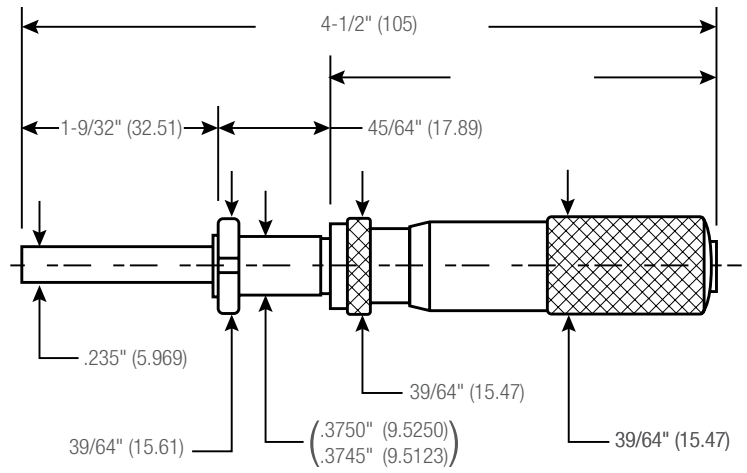

263L-38TN (0-1") dimensions

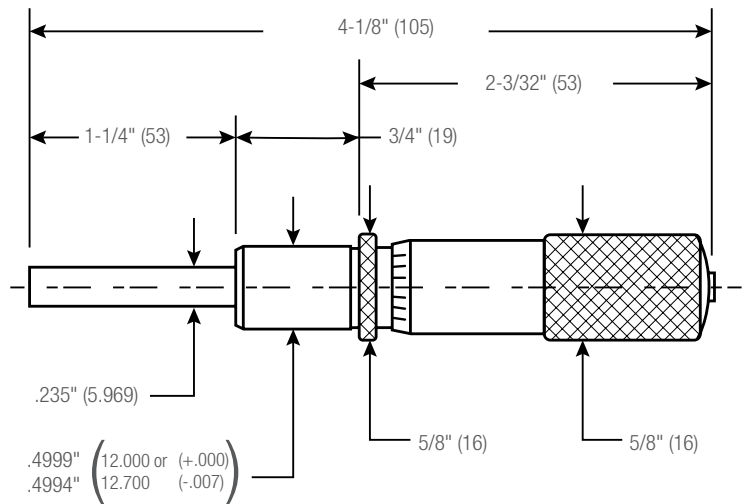

263P (0-1") and 263MP (0-25mm) dimensions

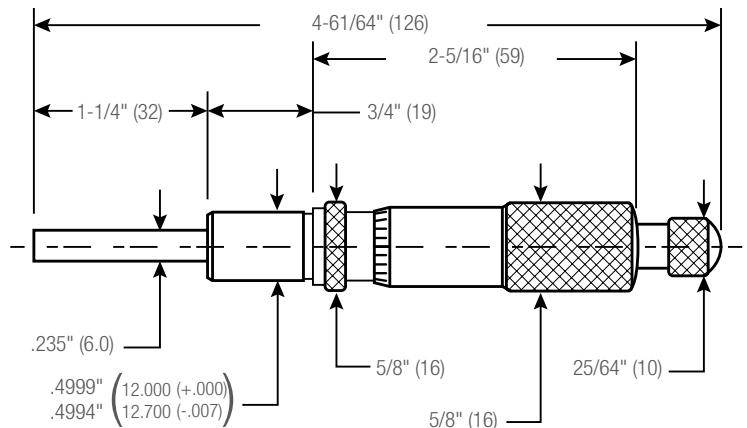

263RL (0-1") and 263MRL (0-25mm) dimensions



MICROMETER HEADS

363 Digital Micrometer Heads

0-1"/0-25MM

READABILITY FEATURES

- Clear, easily read numbers reduce errors
- No-glare black finish on the frame
- Starrett no-glare satin chrome finish on thimble and sleeve
- .001" or 0.01mm is read directly from the counter
- Reverse reading, if needed

EASE-OF-HANDLING FEATURES

- Ring-type knurled lock nut for quick and sure locking
- Choice of smooth friction thimble for uniform pressure or combination ratchet and speeder for uniform pressure and quicker adjustment

ACCURACY AND LONG-LIFE FEATURES

- Extremely hard and stable one-piece spindle (the heart of our accuracy)

363 Digital Micrometer Heads (0-1" Range)

| Cat. No. | EDP | Graduation |
|----------|-------|------------|
| 363L | 56297 | .001" |
| 363RL | 56298 | |
| 363FL | 56299 | |
| RV363RL | 57072 | |

363M Digital Micrometer Heads (0-25mm Range)

| Cat. No. | EDP | Graduation |
|----------|-------|------------|
| 363ML* | 56302 | 0.01mm |
| 363MRL* | 56303 | |
| 363MFL* | 56304 | |

*Specify clamping diameter (12 or 12.7mm). 12.7mm sent unless otherwise ordered.

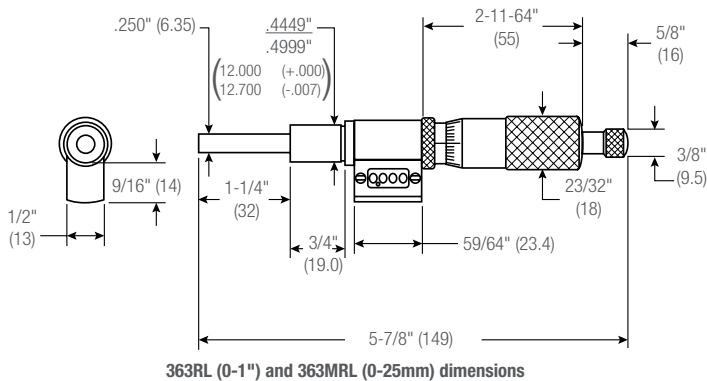

63 LONG RANGE MICROMETER HEADS

0-2"/0-50MM

When long spindle travel is required, the 63 Micrometer heads provide a range that will handle most applications, such as in electronic equipment, machine tools, special gages, tooling, etc.

- With or without ring-type lock nut for quick and sure locking
- With or without the combination ratchet and speeder for uniform pressure and quicker adjustment

63 Micrometer Heads (0-2" Range)

| Cat. No. | EDP | Graduation |
|----------|-------|------------|
| 63P | 50305 | .001" |
| 63L | 50306 | .001" |
| 63RL | 50307 | .001" |
| T63P | 50308 | .0001" |
| T63RL | 50309 | .0001" |

63M Micrometer Heads (0-50mm Range)

| Cat. No. | EDP | Graduation |
|----------|-------|------------|
| 63MRL* | 55939 | 0.01mm |
| V63MRL* | 64343 | 0.002mm |

*0-25mm models specify clamping diameter 12mm or 12.7mm. 12.7mm sent unless otherwise ordered.

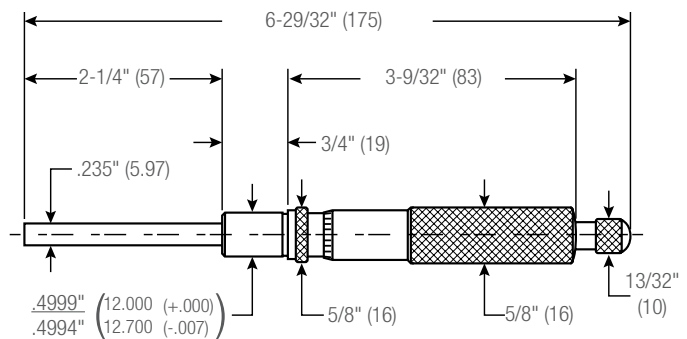
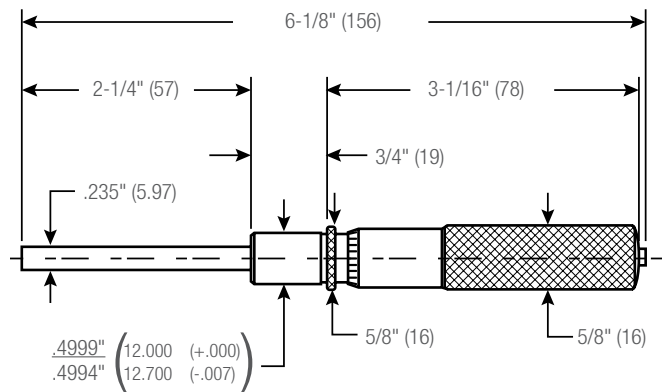

MICROMETER HEADS

663 HEAVY DUTY MICROMETER HEADS

0-1"/0-25MM

The 663 is similar to the 263 but features heavy duty construction with a larger diameter spindle, clamping surface and thimble.

- Available with lock nut and the combination ratchet and speeder for uniform pressure and quicker adjustment, or a plain micrometer head with lock nut only
- Ring-type lock nut for quick and sure locking

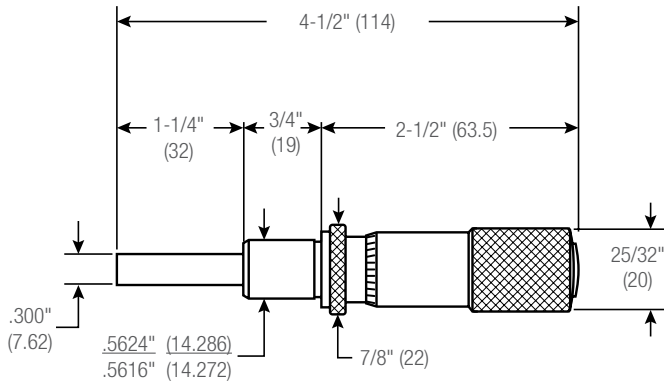

663L (0-1") and 663ML (0-25mm) dimensions

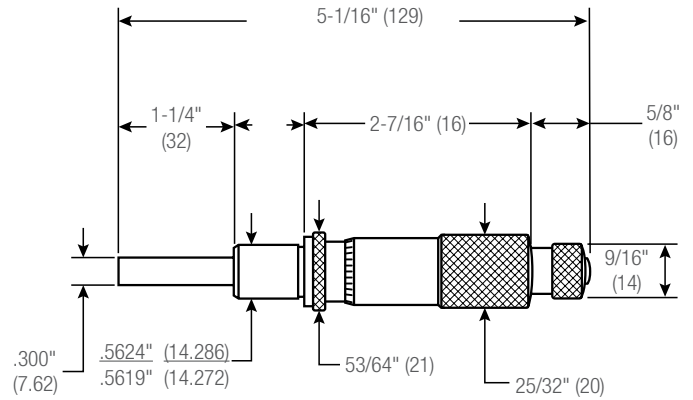

663RL (0-1") and 663MRL (0-25mm) dimensions

| 663 Heavy Duty Micrometer Heads (0-1" Range) | | |
|---|-------|------------|
| Cat. No. | EDP | Graduation |
| 663L | 52772 | .001" |
| 663RL | 52773 | .001" |
| T663L | 52777 | .0001" |
| T663RL | 52778 | .0001" |
| 663M Heavy Duty Micrometer Heads (0-25mm Range) | | |
| Cat. No. | EDP | Graduation |
| 663MRL | 52774 | 0.01mm |
| V663MRL | 64342 | 0.001mm |



663RL

MICROMETER HEADS

465, 468 DIRECT-READING, LARGE MICROMETER HEADS

0-2"/0-50MM

These large micrometer heads are designed for use with electronic equipment requiring ultra-fine adjustment for machine tools, fixtures, special gages and tools, special mountings, or wherever micrometer accuracy in setting and adjustment is required.

Another highly useful feature is the spindle adjustment, which permits adjusting the spindle length approximately $\pm 1/16"$ (1.5mm). If the spindle is to be located against a definite stop and a different zero position is required, first loosen the cap screw in the end of the thimble, position the spindle to the desired location, then holding the spindle in position, rotate the thimble to zero and retighten the cap screw. In achieving this adjustable feature, we have still retained our positive taper-lock large thimble bearing.

The 468 Micrometer heads are exactly the same as the 465, except that they have double figures in red and black on the sleeve and thimble, permitting reading both ways with the spindle moving in either direction. This feature is invaluable on many instruments and microwave applications.

READABILITY, ACCURACY AND LONG-LIFE FEATURES

- 2-1/16" (52mm) thimble diameter with widely spaced .0001" or 0.002mm graduations for direct reading
- All graduations are direct reading – no vernier lines to match
- All reading surfaces have Starrett satin chrome finish as the no-glare background for the sharp lines and figures
- All graduations on sleeves and thimbles have advanced styling with staggered graduations for easy reading
- The spindle is carbide faced for long life
- Thimble and sleeve are made of aluminum to reduce weight
- Furnished with a speeder (not a ratchet) for quicker adjustment
- Extremely hard and stable one-piece spindle for accuracy and long-life
- Micro-lapped measuring face for flatness and squareness
- Quick and easy adjustment

| 465 Micrometer Heads | | | |
|----------------------|-------|--------|------------|
| Cat. No. | EDP | Range | Graduation |
| T465XSP-1 | 67121 | 0-1" | .0001" |
| T465XSP-2 | 67122 | 0-2" | .0001" |
| 465MXSP-25* | 67123 | 0-25mm | 0.002mm |
| 465MXSP-50* | 67124 | 0-50mm | 0.002mm |
| 468 Micrometer Heads | | | |
| Cat. No. | EDP | Range | Graduation |
| T468XSP-1 | 67125 | 0-1" | .0001" |
| T468XSP-2 | 67126 | 0-2" | .0001" |
| 468MXSP-25* | 67127 | 0-25mm | 0.002mm |
| 468MXSP-50* | 67128 | 0-50mm | 0.002mm |

*Metric models specify clamping diameter 25 or 25.4mm. 25.4mm sent unless otherwise ordered.



T465XSP-1

T468XSP-1 with double figures in red and black on sleeve and thimble for reading both ways.

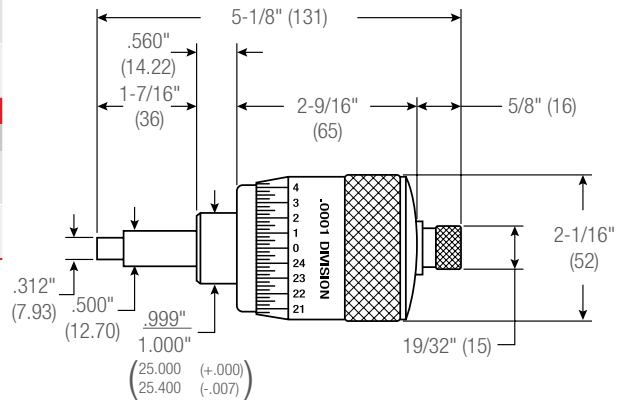

465, 468 Models (0-1"/0-25mm) dimensions

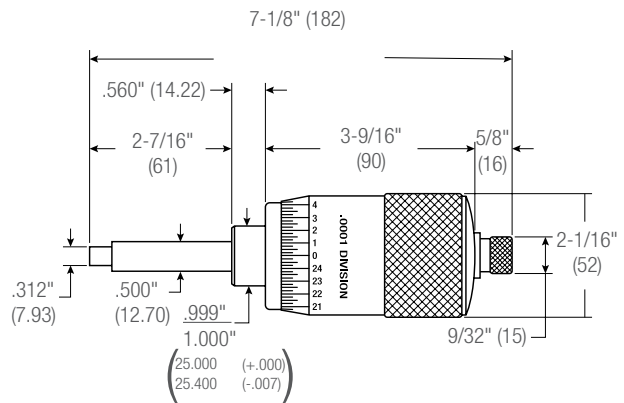

465, 468 Models (0-2"/0-50mm) dimensions



MICROMETER HEADS

469 LARGE, SUPER-PRECISION MICROMETER HEADS

0-1"/0-25MM

These are our most accurate micrometer heads. They are also available on special order with double graduations in red and black on the sleeve and thimble, permitting readings both ways with the spindle moving in either direction.

These micrometer heads have a 4-1/16" (103mm) thimble diameter and are graduated to .0001", .000050", 0.001mm, or 0.002mm for direct reading. They also have staggered graduations for easy counting and reading of lines. Spindle is carbide faced for long life.

| 469 Large, Super-Precision Micrometer Heads (0-1" Range) | | |
|---|-------|------------|
| Cat. No. | EDP | Graduation |
| T469HXSP | 67129 | .000050" |
| T469XSP | 67130 | .0001" |
| 469M Large, Super-Precision Micrometer Heads (0-25mm Range) | | |
| Cat. No. | EDP | Graduation |
| 469MHXSP* | 67131 | 0.001mm |
| 469MXSP* | 67132 | 0.002mm |

*Metric models specify clamping diameter 25 or 25.4mm. 25.4mm sent unless otherwise ordered.
Also available on special order with double graduations for reading both ways with spindle moving in either direction.

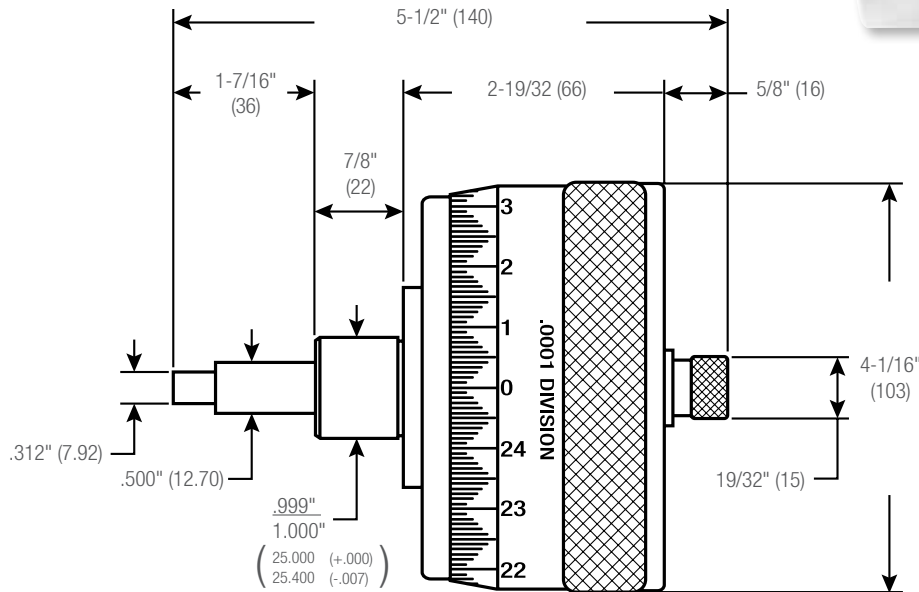
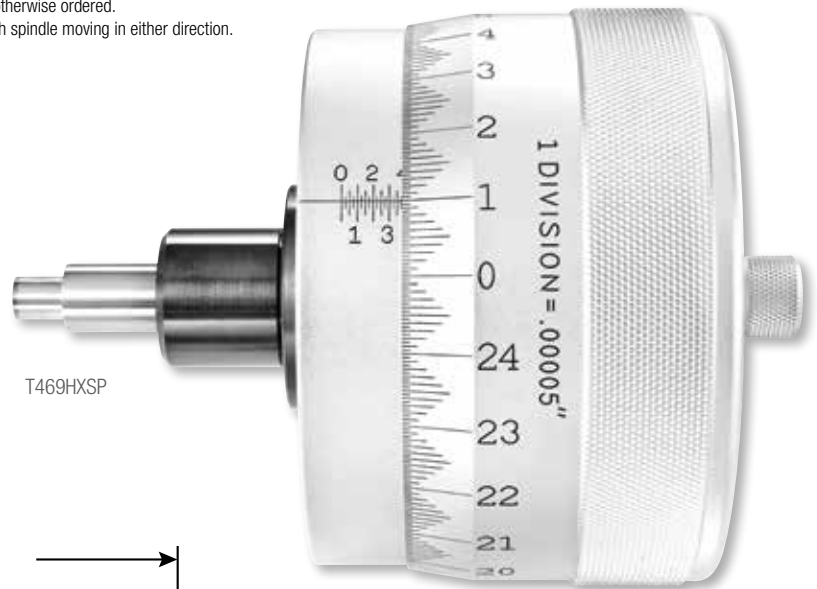

469 (0-1") and 469M (0-25mm) dimensions



INDICATING MICROMETERS

430 INDICATING MICROMETER

The 430 Dial Indicating Micrometer has a Vernier scale in inch for taking precise outside diameter (OD) measurements and dial gage for Go/No-Go (GO/NG) tolerance inspection. A retractable, quick-release anvil allows for uniform consistent pressure during measurement.

| 430 Indicating Micrometers | |
|-------------------------------|--------------------|
| Cat. No. | EDP |
| 430XLZ-1 | 72533 |
| 3206 Outside Micrometer Stand | |
| Cat. No. | EDP |
| 3206 | 68917 |
| Specifications | |
| Micrometer Range | 0-1" |
| Indicator Range | ±.0020" |
| Micrometer Resolution | .0001" |
| Indicator Resolution | .00005" |
| Measuring Force | 5-10N (500-1000gf) |
| Measuring Faces | Carbide |
| Repeatability | ±.00005" |
| Flatness | .000012" |
| Parallelism | .000036" |

FEATURES

- Retractable, quick release anvil for uniform, consistent, and fast measurement
- Insulated frame to prevent thermal expansion/contraction
- Balanced frame and thimble design for ease of use
- Carbide measuring finish on anvils
- Friction thimble
- Satin chrome finish for rust and glare resistance
- Spindle lock
- Supplied with custom wooden case

NEW!

MICROMETERS



430XLZ-1

HOW TO USE FOR DIRECT MEASURE AND AS A COMPARATOR

For direct measuring, the micrometer head is set to zero and the dial indicator is set to zero by the bezel adjustment. Any workpiece within the 1" (25mm) range can then be measured by the micrometer head in ten-thousandths of an inch (.0001" or 0.002mm). The indicator must read zero for each measurement.

If used as a comparator, first set the head and the indicator to zero as previously explained. Then adjust the micrometer head to the desired dimension to be checked. After retracting the anvil, work is placed on the table between anvil and spindle and the anvil is then released so anvil and spindle contact the work. Plus or minus deviation from the nominal work size is then read from the dial indicator in fifty-millionths of an inch (.000050") or 0.002mm.



BENCH MICROMETERS

777 ELECTRONIC BENCH MICROMETERS (WITH OUTPUT)

0-1"/0-25MM

The 777 Electronic Bench Micrometer is especially suited for precision measurements where the work must be brought to the gage.

Work is staged between the anvil and spindle on an adjustable table, which can be raised to a selected height and locked in position by turning a knurled thumb screw on back of the base. Made of cast iron with black wrinkle finish, the base is heavily proportioned to sustain gage accuracy and assure stability in use. It stands on three machined pads.

With Standard Inch Graduations on Shell and Thimble

| Cat. No. | EDP | Description |
|----------|-------|-------------------|
| 777XFLZ | 67135 | 0-1"/0-25mm Range |

With Standard Millimeter Graduations on Shell and Thimble

| Cat. No. | EDP | Description |
|-----------|-------|-------------------|
| 777MEXFLZ | 67136 | 0-25mm/0-1" Range |

Cable Information

| Part No. | EDP | Description |
|----------|-------|--|
| 733SCKB | 69888 | USB cable to PC (In focused window) |
| 733SCU | 69898 | Cable to computer running SPC Data Collection Software |
| 733SCM | 69893 | Connection to 7612, 7613 Multiplexer or RMS 2704 |
| PT61963 | 66636 | Computer Interface Cable Complete to PC (RS232C) |
| PT61120 | 65446 | One 3-Volt Battery CR2450 |

READABILITY FEATURES

- Large, right-sized, high-contrast LCD digital readout is easy to read and reduces errors
- Conventional inch or millimeter graduations standard
- Attractive no-glare black wrinkle finish on the frame

EASE-OF-HANDLING FEATURES

- Ring-type knurled lock nut for quick and sure locking
- Smooth friction thimble for uniform pressure

ACCURACY AND LONG-LIFE FEATURES

- Extremely hard and stable one-piece spindle
- The spindle and anvil are carbide faced for long life
- One 3-volt battery furnished for dependable power and over one year's normal usage
- Automatic OFF after 30 minutes of nonuse
- Starrett workmanship

FULL-FUNCTION ACTION FEATURES

- Instant inch/millimeter conversion
- "ME" millimeter model will turn on in the millimeter mode after installation of a new battery
- Measurement HOLD button
- Ability to zero tool at any position
- Ability to retain and return to the true zero reading of the micrometer
- PRESET button to install any reading at any position
- Ability to install minimum and maximum limits
- RS232 data output port
- Works well with DataSure® Wireless Data Collection Systems



777MEXFLZ

BENCH MICROMETERS

673 DIRECT-READING BENCH MICROMETERS

0-2"/0-50MM

The 673 Bench Micrometer is a high precision instrument, ideal for bench use either in a shop environment or inspection laboratory. It can be used as a comparator measuring to fifty-millionths of an inch (.000050") or two-thousandths of a mm (0.002mm) or for direct measuring to .0001" or 0.002mm. Work lengths up to 2" or 50mm can be measured.

- The base is a heavy, rigid casting, incorporating at the left end a movable anvil which actuates a linear, friction-free motion transfer mechanism between the anvil and the indicator. This assures high accuracy.
- The large thimble diameter, approximately 3" (77mm), makes possible widely spaced graduations that are easy to read without a vernier scale reference
- Advanced, staggered design and quick reading graduations in combination with Starrett no-glare satin chrome finish on both thimble and sleeve also contribute to easier, faster readings
- The head is furnished with a speeder and has a special ring-type lock nut which firmly holds the spindle at any setting without distortion
- Another useful feature is the adjustable work table centered beneath the anvil and spindle. Work can be accurately aligned between the anvil and spindle by adjusting the table to the proper height and locking it in position.
- The spindle and anvil are carbide faced for long life
- To read to ten-millionths of an inch (.000010") or 0.0001mm, this bench micrometer can be used with both the 776 Electronic Digital Gage Amplifier (LVDT probe 776-2Z) or on the 717 Analog Amplifier (LVDT probe 715-2Z). Both require 673A adapter.

673 and 673M Direct-Reading Bench Micrometers

| Cat. No. | EDP | Range Micrometer Head | Dial Indicator | Graduation Micrometer Head | Dial Indicator | Work Table |
|----------|-------|--------------------------|----------------|-------------------------------|----------------|--|
| 673XZ | 67191 | 0-2" | .006" (0-3-0) | .0001" | .000050" | 2-1/4" dia. and 7/8" vertical adjustment |
| 673MXZ | 67192 | 0-50mm | 0.2mm (0-10-0) | 0.002mm | 0.002mm | 57mm dia. and 22mm vertical adjustment |

673 and 673M Accessories

| Cat. No. | EDP | Description |
|----------|-------|--|
| 673A | 52891 | Adapter for 715-2Z LVDT Length Probe (to connect both 717 and 776 Gage Amplifiers) |
| 776-2Z | 68818 | LVDT Length Probe (776 Gage Amplifier) |
| 715-2Z | 64480 | LVDT Length Probe (717 Gage Amplifier) |

Anvil Pressure Adjustment – 8 oz. to 3 lb (0.23 to 1.36kg)



673M with 717 amplifier



HOW TO USE FOR DIRECT MEASURE AND AS A COMPARATOR

For direct measuring, the micrometer head is set to zero and the dial indicator is set to zero by the bezel adjustment. Any workpiece within the 2" (50mm) range can then be measured by the micrometer head in ten-thousandths of an inch (.0001" or 0.002mm). The indicator must read zero for each measurement.

If used as a comparator, first set the head and the indicator to zero as previously explained. Then adjust the micrometer head to the desired dimension to be checked. After retracting the anvil, work is placed on the table between anvil and spindle and the anvil is then released so anvil and spindle contact the work. Plus or minus deviation from the nominal work size is then read from the dial indicator in fifty-millionths of an inch (.000050") or 0.002mm.

END MEASURING RODS AND STANDARDS

234 END MEASURING RODS WITH SPHERICAL ENDS

1-24"/25-600MM

These rods or "standards" are for checking and setting micrometers of 2" capacity and larger, and are also used on machine tools for comparing gages, checking precision measuring tools, for measuring parallel surfaces, and many other types of work.

They are made of special tool steel in rod form with ends hardened and accurately lapped to a spherical radius.

Available plain or with insulated handles to minimize expansion by heat when held in the hand. 1-6" (25-150mm) sizes are 1/4" (6.3mm) diameter; 7-11" (175-275mm) sizes, 3/8" (9.5mm) diameter; 12-24" (300-600mm) sizes are 7/16" (11mm) diameter.

NOTE: These standards are the ones used for all micrometers furnished with standards. Larger sizes available on special order.

234 End Measuring Rods

| With Insulating Handle | | |
|------------------------|-------|--------|
| Cat. No. | EDP | Length |
| 234A-1 | 50969 | 1" |
| 234A-2 | 50971 | 2" |
| 234A-3 | 50973 | 3" |
| 234A-4 | 50975 | 4" |
| 234A-5 | 50977 | 5" |
| 234A-6 | 50979 | 6" |
| 234A-7 | 50981 | 7" |
| 234A-8 | 50983 | 8" |
| 234A-9 | 50985 | 9" |
| 234A-10 | 50987 | 10" |
| 234A-11 | 50989 | 11" |
| 234A-12 | 50991 | 12" |
| 234A-13 | 50993 | 13" |
| 234A-14 | 50995 | 14" |
| 234A-15 | 50997 | 15" |
| 234A-16 | 50999 | 16" |
| 234A-17 | 51001 | 17" |
| 234A-18 | 51003 | 18" |
| 234A-19 | 51005 | 19" |
| 234A-20 | 51007 | 20" |
| 234A-21 | 51009 | 21" |
| 234A-22 | 51011 | 22" |
| 234A-23 | 51013 | 23" |
| 234A-24 | 51015 | 24" |

234M End Measuring Rods

| With Insulating Handle | | |
|------------------------|-------|--------|
| Cat. No. | EDP | Length |
| 234MA-25 | 50970 | 25mm |
| 234MA-50 | 50972 | 50mm |
| 234MA-75 | 50974 | 75mm |
| 234MA-100 | 50976 | 100mm |
| 234MA-125 | 50978 | 125mm |
| 234MA-150 | 50980 | 150mm |
| 234MA-175 | 50982 | 175mm |
| 234MA-200 | 50984 | 200mm |
| 234MA-225 | 50986 | 225mm |
| 234MA-250 | 50988 | 250mm |
| 234MA-275 | 50990 | 275mm |
| 234MA-300 | 50992 | 300mm |
| 234MA-325 | 50994 | 325mm |
| 234MA-350 | 50996 | 350mm |
| 234MA-375 | 50998 | 375mm |
| 234MA-400 | 51000 | 400mm |
| 234MA-425 | 51002 | 425mm |
| 234MA-450 | 51004 | 450mm |
| 234MA-475 | 51006 | 475mm |
| 234MA-500 | 51008 | 500mm |
| 234MA-525 | 51010 | 525mm |
| 234MA-550 | 51012 | 550mm |
| 234MA-575 | 51014 | 575mm |
| 234MA-600 | 51016 | 600mm |

| Standards for S436.1 and S436 Micrometer Sets | | With SLC | | |
|---|-------|-------------|-------|------------------------------|
| Cat. No. | EDP | Cat. No. | EDP | Description |
| S234C | 50852 | | | Set of two standards only |
| S234D | 51897 | | | Set of three standards only |
| S234E | 50860 | S234E W/SLC | 66878 | Set of five standards only |
| S234G | 51929 | S234G W/SLC | 66877 | Set of eleven standards only |
| S234F | 51917 | S234F W/SLC | 66879 | Set of six standards only |
| S234J | 64146 | | | Set of twelve standards only |

| Standards for S436.1M and S436M Micrometer Sets | | |
|---|-------|------------------------------|
| Cat. No. | EDP | Description |
| S234MC | 51893 | Set of two standards only |
| S234MD | 51901 | Set of three standards only |
| S234ME | 51913 | Set of five standards only |
| S234MF | 51925 | Set of six standards only |
| S234MG | 51937 | Set of eleven standards only |
| S234MJ | 64467 | Set of twelve standards only |



234A-2



234A-6

END MEASURING RODS

PRECISION END MEASURING RODS AND INSIDE MICROMETERS

The following pages show our varied line of precision end measuring rods and inside micrometers. The variations are fixed-range or adjustable-range micrometers and solid or tubular measuring rods.

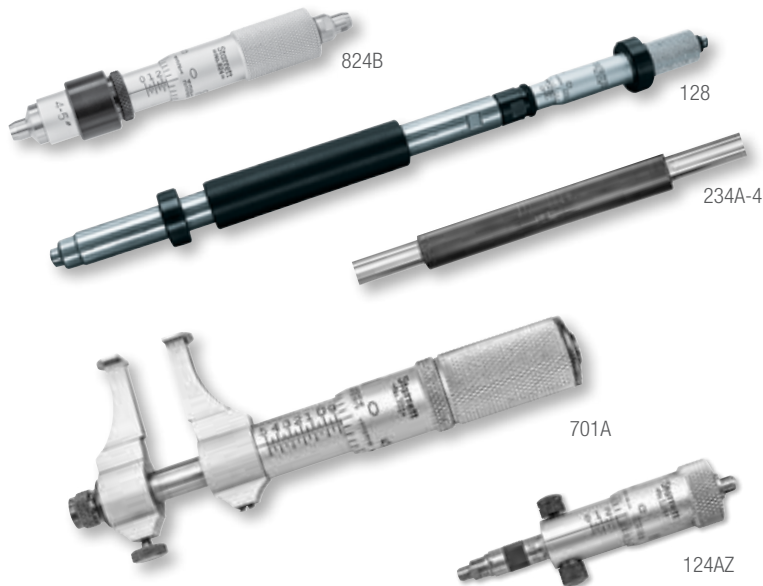

Unless otherwise noted under the individual tools, all have these features:

- Balanced design for better feel and accurate measurement
- All contact points are hardened and ground for better accuracy and long life
- Satin chrome finish on all micrometer heads and reading surfaces that resist rust and also make for easy reading by providing a no-glare background for the sharp lines and figures
- Hardened and stabilized spindle for accuracy and long life
- Advanced sleeve design with staggered lines and distinct figures for precise and easy readability
- Quick and easy adjustment
- Starrett workmanship
- Inside Micrometers 121, 124, 823 and 824 by design have a firmer rotation than regular micrometers. This is to limit the tendency of the micrometer head to rotate when withdrawn from the workpiece.

MEASURING TIPS FOR INSIDE MEASUREMENTS

Whether to use a two-point or three-point contact measuring tool is usually a matter of preference, but there are some differences.

A two-point contact rod-type inside micrometer shown in this section is usually lighter, easier to handle, and more versatile over long ranges from approximately 6-107" (150-2700mm). Any two-point contact micrometer, regardless of range, can probe a hole better to find the geometry of that hole than a three-point contact.

Most three-point contact tools have setting rings to ensure accuracy. If you desire very close tolerance work with two-point contact inside micrometers, it is recommended that they be set to a ring gage or to an outside micrometer.

A three-point contact micrometer shown in the Bore Gages section has an advantage in that it can be seated in position more quickly than a two-point contact tool. Usually these tools can also be read to a finer accuracy. The three-point tool will tell the maximum true diameter that can enter the hole a little faster than a two-point contact tool.

Micrometer heads used in these tools are accurate to ± 0.0001 " or 0.002mm, but overall accuracy on tools that add rods is dependent on good practice and technique.

To ensure accuracy, these practices should be followed:

- Always make sure that there are no specks of dirt between the clamping surfaces of the rods and micrometer heads
- Tighten all rods uniformly, not too tight, not too loose, but a fairly firm assembly
- Assemble long sections vertically or, with support, horizontally
- Because temperature can affect long rods used in these tools, they should be assembled in the same environment in which they will be used

For additional information, refer to the Bore Gage Section.



INSIDE MICROMETERS

128 COMBINATION HEAD WITH INSIDE MICROMETER

The combination head for inside micrometers combines the precision of a dial indicator sensor and the linear accuracy of a micrometer. This combination of indicator and micrometer reduces the need for operator "feel" and provides faster readings with increased reliability.

This head is interchangeable with the 128 End Rods and extension combinations.

For direct measurements, the dial indicator hand and the telltale hand must both register zero before reading the micrometer. As a comparator, the micrometer is first set to the nominal dimension and \pm deviation from zero is read from the dial indicator. The gage should be rocked to obtain a minimum reading on the indicator. Out-of-roundness can also be checked – any variation being shown by the indicator.

For inch-reading tools, the head can be adjusted within a range of 2". It extends the overall range by an additional 5". The special 81-138J Jeweled Non-Shock Indicator is graduated .0005", range \pm .040" and reads 0-40 on both the plus and minus dials.

For millimeter-reading tools, the head can be adjusted within a range of 50mm. This extends the overall range an additional 125mm. The special 81-181J Jeweled Non-Shock Indicator is graduated 0.01mm, range \pm 1mm and reads 0-100mm on both the plus and minus dials.

All inside micrometer masters should be used vertically with the shoulder on the indicator end of the head, seated squarely.

128 SETS

6-294"/150-7350MM

Each set consists of a satin-chrome micrometer head which can be used in combination with any one or more of a series of rigid, tubular steel measuring rods to obtain the required length.

The micrometer head is a modification of our 63, which has a 2" (50mm) range. The head has a basic length of 4" (100mm) which can be lengthened to 6" (150mm) by means of its measuring range. Besides those listed on the lead page of this section, the 128 Sets have these additional features:

- For inside measurements from 6-294" (150-7350mm) (longer sizes are also available on special order)
- Interchangeable tubular steel measuring rods and extension rods are lightweight with extreme rigidity. Rods screw into each other and seat against hardened ground and lapped surfaces necessary for high accuracy. Rod diameter 5/8" (16mm).
- Rods are provided with insulated handles to minimize expansion from hand heat. All rods marked with length
- All rod anvil contacts are hardened and ground
- All measuring rod anvil contacts are adjustable (plain extension rods are not adjustable)
- Adjustable, ground steel supporting collars (placed in "V" grooves when used in the horizontal position)



128CZ

128 and 128M Combination Head with Inside Micrometer Sets

| Cat. No. | EDP | Description |
|----------|-------|---|
| 128 | 64381 | Inch-reading combination head with setting master |
| 128M | 68117 | Millimeter-reading combination head with setting master |



128 with rod

128

128 and 128M Micrometer Head Sets

| Cat. No. | EDP | Range with Micrometer Head | Movement of Screw | Grad. | Description | Range with Combination Head |
|----------|-------|----------------------------|-------------------|--------|--|-----------------------------|
| 128AZ | 64375 | 6-78" | 2" | .001" | With (1) 4-6" head, (1) each 2", 4", 6", 8", 10", 12" rods, (1) 12" ext., (2) 24" ext. | 11-83" |
| 128BZ | 64376 | 6-150" | 2" | .001" | With (1) 4-6" head, (1) each 2", 4", 6", 8", 10", 12" rods, (1) 12" ext., (5) 24" ext. | 11-155" |
| 128CZ | 64377 | 6-294" | 2" | .001" | With (1) 4-6" Head, (1) each 2", 4", 6", 8", 10", 12" rods, (1) 12" ext., (1) 24" ext. | 11-299" |
| 128MAZ | 64378 | 150-1950mm | 50mm | 0.01mm | With (1) 100-150mm head, (1) ea. 50, 100, 150, 200, 250, 300mm rods, (1) 300mm ext., (2) 600mm ext. | 300-2100mm |
| 128MBZ | 64379 | 150-3750mm | 50mm | 0.01mm | With (1) 100-150mm head, (1) ea. 50, 100, 150, 200, 250, 300mm rods, (1) 300mm ext., (5) 600mm ext. | 300-3900mm |
| 128MCZ | 64380 | 150-7350mm | 50mm | 0.01mm | With (1) 100-150mm head, (1) ea. 50, 100, 150, 200, 250, 300mm rods, (1) 300mm ext., (11) 600mm ext. | 300-7500mm |

MICROMETER SETS

124 SOLID-ROD INSIDE MICROMETER SETS

2-32"/50-800MM

These are the most popular inside micrometers because of their lightness, ease of use, and range. They are very useful for measuring inside diameters of cylinders and rings, measuring parallel surfaces, etc.

The desired range is obtained by assembling rods and spacing collars to the micrometer head. Measuring rods are provided with a shoulder that is set accurately in the micrometer head and locked in position. When assembling rods to the A and B heads, the reading line on the micrometer head should be lined up with the marking on each rod (except for the 2-3" and the 50-75mm rods).

Rod diameters are approximately 1/4" (6mm) on the A and B sizes, and approximately 11/32" (8.5mm) on the C size. Each rod has individual length adjustment for the anvil by means of special wrenches furnished.

- Measuring rods are solid and assembled on one side of the micrometer head
- Insulated rods marked with length
- Hardened and ground anvils on rods, adjustable for length. Head anvil is hardened and ground
- Quick-reading figures – every thousandth numbered on inch reading tools
- Convenient handle is available to provide reach for use in deep holes. Handle screws into the micrometer head in place of the dummy screw, which is opposite a rod lock screw. Distance from the end of the handle to the center line is 6-1/4" (158mm).



124AZ



H124 Head

124 Solid-Rod Inside Micrometer Sets (.001" Graduation)

| Without Case | | With Case | | Range | Screw Movement | Measuring Rods | Spacing Collars |
|--------------|-------|-----------|-------|-------|----------------------|-------------------|-----------------|
| Cat. No. | EDP | Cat. No. | EDP | | | | |
| 124A | 50540 | 124AZ | 50542 | 2-8" | 1/2" | 6 | One 1/2" |
| 124B | 50544 | 124BZ | 50546 | 2-12" | 1/2" | 10 | One 1/2" |
| 124C | 50548 | 124CZ | 50550 | 8-32" | 1" | 4 | One 1", Two 2" |
| 124D | 50552 | 124DZ | 50554 | 2-32" | 1/2 and 1" (2 heads) | Set 124A and 124C | |

124M Solid-Rod Inside Micrometer Sets (0.01mm Graduation)

| Without Case | | With Case | | Range | Screw Movement | Measuring Rods | Spacing Collars |
|--------------|-------|-----------|-------|-----------|-----------------------|-----------------------------------|--------------------|
| Cat. No. | EDP | Cat. No. | EDP | | | | |
| 124MA | 50541 | 124MAZ | 56141 | 50-200mm | 13mm | 6 | One 12mm |
| 124MB | 50545 | 124MBZ | 56142 | 50-300mm | 13mm | 10 | One 12mm |
| 124MC | 50549 | 124MCZ | 56143 | 200-800mm | 25mm | 4 | One 25mm, Two 50mm |
| 124MD | 50553 | 124MDZ | 56144 | 50-800mm | 13 and 25mm (2 heads) | Comprised of sets 124MA and 124MC | |

Accessory for 124 and 124M Solid-Rod Inside Micrometer Sets

| Cat. No. | EDP | Description |
|----------|-------|-----------------------|
| 124H | 50556 | 6-1/4" (158mm) handle |



MICROMETER SETS

823 TUBULAR INSIDE MICROMETER SETS

1-1/2-40"/40-1000MM

The 823 Micrometers are highly useful tools for internal linear measurements such as measuring cylinders, rings, setting calipers, comparing gages and measuring parallel surfaces.

The extension rods are made of steel tubing, light in weight, yet extremely rigid. Rods are approximately 3/8" (9.5mm) diameter to meet the requirements of mechanics who prefer this larger diameter. By removing the hardened and ground anvil ends (end caps) of the micrometer head, the rods may be attached to either or both ends of the micrometer as preferred. Each rod may be individually adjusted for wear by the hardened and ground anvil at the end.

- Tubular measuring rods are lightweight, yet extremely rigid. Rods are insulated, with the exception of 1/2" (13mm) and 1" (25mm) sizes.
- Each rod is marked with length
- Hardened and ground anvils on rods are adjustable for length. Head anvil is hardened and ground.
- Interchangeable anvils on both 1/2" (13mm) and 1" (25mm) heads
- Quick reading figures – every thousandth numbered on inch reading tools
- Lock nut furnished on 1" (25mm) heads
- 5-1/2" (140mm) long, convenient handle furnished on A, B, F micrometers may be clamped where it will provide correct balance and reach



823AZ 1-1/2-8" set with tool, rods, handle and wrenches

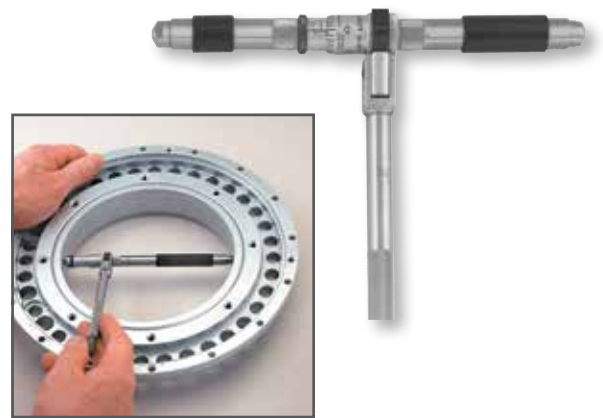

Rods attachable as shown to either one or both ends of the head ensures the best balance, feel, and ease of reading.



823EZ 4-40" set with tool, rods, handle and wrenches.

823 Tubular Inside Micrometer Sets (.001" Graduation)

| Cat. No. | EDP | Range | Movement of Screw | Description |
|----------|-------|-----------|----------------------|-------------------------|
| 823AZ | 53050 | 1-1/2-8" | 1/2" | With 5 rods and handle |
| 823BZ | 53052 | 1-1/2-12" | 1/2" | With 8 rods and handle |
| 823CZ | 53054 | 4-24" | 1" | With 7 rods |
| 823DZ | 53055 | 4-32" | 1" | With 8 rods |
| 823EZ | 53056 | 4-40" | 1" | With 10 rods |
| 823FZ | 53058 | 1-1/2-32" | 1/2 and 1" (2 heads) | With 10 rods and handle |

823M Tubular Inside Micrometer Sets (0.01mm Graduation)

| Cat. No. | EDP | Range | Movement of Screw | Description |
|----------|-------|------------|-------------------|------------------------|
| 823MAZ | 53051 | 40-200mm | 13mm | With 6 rods and handle |
| 823MBZ | 53053 | 40-300mm | 13mm | With 8 rods and handle |
| 823MEZ | 53057 | 100-1000mm | 25mm | With 10 rods |

Each set furnished in attractive, protective case with assembly instructions for various measurements.

INSIDE MICROMETERS

121 LONG RANGE TUBULAR INSIDE MICROMETER SETS

32-107"

The 121 Tubular Inside Micrometers are designed for large internal measurements beyond the capacity of most other micrometers. Each set consists of a micrometer head mounted at the end of a tubular holder in which measuring rods can be inserted and adjusted to the desired size. Final size reading in thousandths of an inch (.001") is obtained using the micrometer head.

Rods and holder are made of steel tubing, light in weight, yet very rigid. Each rod is accurately graduated with inch divisions, which are set to the size desired by a line on the holder, and firmly held by a large, knurled clamping nut. The collet has a design that insures an extremely tight grip on the rods at any setting.

FEATURES

- Insulated rod holder to eliminate expansion by heat when hand held
- Attractive nickel-plated finish; satin-chrome finish on micrometer head reading surfaces
- Rods are accurately graduated in inches – micrometer head in thousandths of an inch
- Hardened and ground anvils. All rod anvils are adjustable.
- Quick, easy adjustment for micrometer screw

| 121 Long Range Tubular Inside Micrometer Sets (.001" Graduation) | | | | |
|--|-------|---------|-------------------|--|
| Cat. No. | EDP | Range | Movement of Screw | Description |
| 121AZ | 50492 | 32-57" | 1" | With 1 graduated measuring rod |
| 121BZ | 50493 | 32-82" | | With 2 graduated measuring rods and 1 extension rod |
| 121CZ | 50494 | 32-107" | | With 3 graduated measuring rods and 2 extension rods |

Each set furnished in attractive, protective case.



121CZ

824 FIXED RANGE INSIDE MICROMETERS AND SETS

2-12"/50-150MM

For those who prefer inside micrometers without interchangeable rods, Starrett offers this series of fixed range inside micrometers. The 824 and 824M can be ordered individually or in sets. All 824 and 824M Micrometers feature:

- Insulating handles on all sizes minimize possible expansion by heat when hand held
- Lock nuts (except 824AA and 824MAA)
- Adjustable contacts on thimble end
- Adjustable sleeve for head accuracy

824 Inside Micrometers (.001" Graduation)

| Cat. No. | EDP | Range | Movement of Screw |
|----------|-------|--------|-------------------|
| 824AA | 56665 | 2-3" | 1" |
| 824A | 56666 | 3-4" | |
| 824B | 56667 | 4-5" | |
| 824C | 56668 | 5-6" | |
| 824D | 56669 | 6-7" | |
| 824E | 56670 | 7-8" | |
| 824F | 56671 | 8-9" | |
| 824G | 56672 | 9-10" | |
| 824H | 56673 | 10-11" | |
| 824J | 56674 | 11-12" | |
| 824K | 56675 | 6-8" | 2" |
| 824L | 56676 | 8-10" | |
| 824N | 56677 | 10-12" | |

824M Inside Micrometers (0.01mm Graduation)

| Cat. No. | EDP | Range | Movement of Screw |
|----------|-------|-----------|-------------------|
| 824MAA | 64192 | 50-75mm | 25mm |
| 824MA | 64193 | 75-100mm | |
| 824MB | 64194 | 100-125mm | |
| 824MC | 64195 | 125-150mm | |

824 Fixed Range Inside Micrometer Sets

| Cat. No. | EDP | Total Range | Description |
|----------|-------|-------------|---|
| S824AZ | 56678 | 2-6" | 4 micrometers, 1" range: 2-3", 3-4", 4-5", 5-6" |
| S824BZ | 56679 | 2-12" | 10 micrometers, 1" range: 2-3", 3-4", 4-5", 5-6", 6-7", 7-8", 8-9", 9-10", 10-11", 11-12" |
| S824CZ | 56680 | 6-12" | 3 micrometers, 2" range: 6-8", 8-10", 10-12" |
| S824DZ | 56681 | 2-12" | 7 micrometers, (4) 1" range, (3) 2" range: 2-3", 3-4", 4-5", 5-6", 6-8", 8-10", 10-12" |

824M Fixed Range Inside Micrometer Sets

| Cat. No. | EDP | Total Range | Description |
|----------|-------|-------------|--|
| S824MAZ | 64196 | 50-150mm | 4 micrometers, 25mm Range: 50-75mm, 75-100mm, 100-125mm, 125-150mm |



824A

824B

824C



INSIDE MICROMETERS

700 INSIDE MICROMETER CALIPERS

.200-2"/5-50MM

Caliper-type jaws permit quick inside measurements accurate to $\pm .0002"$ or $\pm 0.005\text{mm}$. Jaws are hardened and ground on a radius for accurate feel without cramping.

- Satin chrome reading surface is glare free and resists rust
- Smooth friction thimble for consistent readings
- Lock screw



| 700 Inside Micrometer Calipers (.001" Graduation) | | |
|---|-------|-------------|
| Cat. No. | EDP | Range |
| 700A | 52909 | .200-1.200" |
| 700B | 52911 | 1-2" |

| 700M Inside Micrometer Calipers (0.01mm Graduation) | | |
|---|-------|---------|
| Cat. No. | EDP | Range |
| 700MA | 56063 | 5-30mm |
| 700MB | 56064 | 25-50mm |

| Case for 700 and 700M Inside Micrometer Calipers | | |
|--|-------|---|
| Cat. No. | EDP | Description |
| 940 | 55359 | Case for 700, 700M inside micrometer calipers |

701 INTERNAL GROOVE MICROMETERS

.500-2.500"

Measures grooves for retaining rings and "O" rings, oil grooves, washer grooves, as well as bores and recesses. Depth of grooves up to 5/64" can be measured with 701A; and 7/32" with 701B. Tool is accurate to $\pm .0002"$.

- Hardened and ground gaging contacts are .030" thick
- Contacts have flush ends to gage grooves at the bottom of blind holes
- Satin chrome reading surface is glare free and resists rust
- Smooth friction thimble for consistent readings
- Lock screw



| 701 Internal Groove Micrometers (.001" Graduation) | | | | | |
|--|-------|--------------|-----------|-----------------|----------------|
| Cat. No. | EDP | Range | Min. Bore | Max. Depth Bore | Thickness Jaws |
| 701A | 52913 | .500-1.500" | .500" | 1/2" | .030" |
| 701B | 52915 | 1.500-2.500" | 1.500" | 7/8" | |

| Case for 701 Internal Groove Micrometers | | |
|--|-------|-----------------|
| Cat. No. | EDP | Description |
| 940 | 55359 | Protective Case |

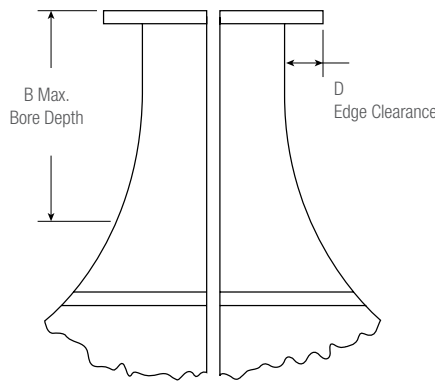
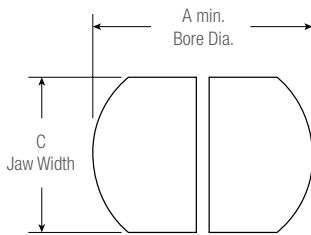

| | 701A | 701B |
|-------|---------|----------|
| Range | .5-1.5" | 1.5-2.5" |
| A | .5" | 1.5" |
| B | 1/2" | 3/4" |
| C | 3/8" | 3/8" |
| D | 3/32" | 1/4" |



DEPTH MICROMETERS

749 ELECTRONIC MICROMETER DEPTH GAGE (WITH OUTPUT)

0-12"/0-300MM

The 749 Electronic Depth Micrometer has a wide 0-12" (0-300mm) range for measuring the depth of most holes, slots, shoulders and projections.

| 749 Electronic Micrometer Depth Gages, Standard Inch Graduations on Shell and Thimble | | |
|---|-------|---------------------|
| Cat. No. | EDP | Description |
| 749BZ-6RL | 65063 | 0-6"/0-150mm range |
| 749BZ-12RL | 68854 | 0-12"/0-300mm range |

| 749M Electronic Micrometer Depth Gages, Standard Millimeter Graduations on Shell and Thimble | | |
|--|-------|---------------------|
| Cat. No. | EDP | Description |
| 749MEBZ-150 | 66124 | 0-150mm/0-6" range |
| 749MEBZ-300 | 68855 | 0-300mm/0-12" range |

| Rods Only for 749 and 749M Electronic Micrometer Depth Gages | | | | | |
|--|-------|-----------|----------|-------|--------|
| Part No. | EDP | mm | Part No. | EDP | Inch |
| PT99486 | 72493 | 0-25mm | PT99143 | 66331 | 0-1" |
| PT99487 | 72494 | 25-50mm | PT99183 | 66332 | 1-2" |
| PT99488 | 72495 | 50-75mm | PT99190 | 66333 | 2-3" |
| PT99489 | 72496 | 75-100mm | PT99266 | 66334 | 3-4" |
| PT99490 | 72497 | 100-125mm | PT99267 | 66335 | 4-5" |
| PT99491 | 72498 | 125-150mm | PT99268 | 66336 | 5-6" |
| PT99457 | 11626 | 150-175mm | PT99531 | 11632 | 6-7" |
| PT99458 | 11627 | 175-200mm | PT99532 | 11633 | 7-8" |
| PT99459 | 11628 | 200-225mm | PT99533 | 11634 | 8-9" |
| PT99460 | 11629 | 225-250mm | PT99534 | 11635 | 9-10" |
| PT99461 | 11630 | 250-275mm | PT99535 | 11636 | 10-11" |
| PT99462 | 11631 | 275-300mm | PT99536 | 11637 | 11-12" |

| Cable Information for 749 and 749M Electronic Micrometer Depth Gages | | |
|--|-------|--|
| Part No. | EDP | Description |
| PT61963 | 66636 | Computer interface cable complete to PC (RS232C) |
| 733SCU | 69898 | USB cable to computer running SPC Data Collection Software |
| 733SCKB | 69888 | USB cable to PC (In focused window) |
| 733SCM | 69893 | Connection to Multiplexer (7612, 7613 or RMS2704) |
| PT61120 | 65446 | One 3-Volt battery CR2450 |

READABILITY FEATURES

- Large high-contrast LCD digital readout
- Resolution: .0001" (0.001mm)
- Inch or millimeter graduations standard
- No-glare black wrinkle finish frame
- No-glare satin chrome finish on thimble and sleeve

EASE-OF-HANDLING FEATURES

- Ring-type knurled lock nut
- Combination ratchet and speeder

ACCURACY AND LONG-LIFE FEATURES

- Ground and lapped one-piece spindle
- Base length 4" (100mm); rod diameter 5/32" (4mm)
- One 3-volt battery furnished with over one year's normal usage
- Automatic OFF after 30 minutes of nonuse
- Full-Function Action Features
- Instant inch/millimeter conversion
- "ME" millimeter model turns on in millimeter mode after battery installation
- Measurement HOLD button
- Ability to zero at any position and retain and return to true zero reading
- PRESET button to install any reading at any position
- Ability to install minimum and maximum limits
- RS232 data output port
- Works well with Starrett DataSure® Wireless Data Collection Systems

DEPTH MICROMETERS

Our varied line of electronic, mechanical digital and regular depth micrometers are available with base lengths from 2-1/2-6" (63.5-150mm) and can measure depths up to 9" (225mm). They are also available with rotating or non-rotating blades. All heads used in our depth micrometers are accurate to ± 0.0001 " or ± 0.002 mm.

Unless otherwise noted under the individual tools, they all have these features:

- A base shape design that will automatically position the fingers so that the base is easily held in place for measuring stability
- All precision screws are ground and lapped
- All bases and rods are hardened, ground, and lapped for permanent accuracy
- All reading surfaces have a satin chrome finish that resists rust and provides a no-glare background for the sharp lines and figures
- All measuring rods are adjustable
- Quick and easy adjustment



749MEBZ-150



DEPTH MICROMETERS

446 DIGITAL MICROMETER DEPTH GAGES

0-6"/0-150MM

446 Mechanical Digital Depth Micrometers are simple to use even by the inexperienced. Besides those listed on the lead page of this section, this tool has these additional features:

- Clear, easily read white numbers on black background reduce errors
- No-glare black finish on the frame
- .001" or 0.01mm is read directly from the counter
- Ring-type knurled lock nut for quick and sure locking
- Combination ratchet and speeder for uniform pressure and quicker adjustment
- Hardened, ground, and lapped base is 3" (75mm) long
- Measuring rods are 5/32" (4mm) diameter and are adjustable

446 Digital Micrometer Depth Gages (.001" Graduation)

| Cat. No. | EDP | Range | Rods |
|-----------|-------|-------|------|
| 446AZ-3RL | 56288 | 0-3" | 3 |
| 446AZ-6RL | 56289 | 0-6" | 6 |

446M Digital Micrometer Depth Gages (0.01mm Graduation)

| Cat. No. | EDP | Range | Rods |
|--------------|-------|---------|------|
| 446MAZ-75RL | 56294 | 0-75mm | 3 |
| 446MAZ-150RL | 56295 | 0-150mm | 6 |

Rods Only for 446 & 446M Digital Micrometer Depth Gages

| For 446 (in) | | | For 446M (mm) | | |
|--------------|-------|------|---------------|-------|-----------|
| Part No. | EDP | Size | Part No. | EDP | Size |
| PT99381 | 72211 | 0-1" | PT99391 | 72217 | 0-25mm |
| PT99382 | 72212 | 1-2" | PT99392 | 72218 | 25-50mm |
| PT99383 | 72213 | 2-3" | PT99393 | 72219 | 50-75mm |
| PT99384 | 72214 | 3-4" | PT99394 | 72220 | 75-100mm |
| PT99385 | 72215 | 4-5" | PT99395 | 72221 | 100-125mm |
| PT99386 | 72216 | 5-6" | PT99396 | 72222 | 125-150mm |



446AZ-6RL





DEPTH MICROMETERS

449 MICROMETER DEPTH GAGES WITH NON-ROTATING BLADES

0-6"/0-150MM

By holding the base in one hand, the .045" thick x 1/8" wide (1.2 x 3.2mm) blade can be turned with the fingers and positioned at any angle relative to the base. In operation, blade does not turn, but moves perpendicularly only, permitting depth measurement of narrow shoulders without the blade rolling off. This is also ideal for slots and recesses as narrow as .045" (1.2mm). Furnished with a 2-1/2" (63mm) or a 4" (100mm) base.

Also available with 3 rods for measuring 0-3" (0-75mm), or 6 rods for measuring 0-6" (0-150mm) in thousandths of an inch or 0.01mm.

This tool comes with the combination ratchet and speeder for uniform pressure and quicker adjustment.

449 Micrometer Depth Gages (.001" Graduation)

| Cat. No. | EDP | Range | Base Length | Rods | Rod Size |
|----------|-------|-------|-------------|------|-------------|
| 449AZ-3R | 52318 | 0-3" | 2-1/2" | 3 | .045 x 1/8" |
| 449AZ-6R | 52320 | 0-6" | 2-1/2" | 6 | |
| 449BZ-3R | 52322 | 0-3" | 4" | 3 | |
| 449BZ-6R | 52324 | 0-6" | 4" | 6 | |

449M Micrometer Depth Gages (0.01mm Graduation)

| Cat. No. | EDP | Range | Base Length | Rods | Rod Size |
|-------------|-------|---------|-------------|------|-------------|
| 449MAZ-75R | 56636 | 0-75mm | 63.5mm | 3 | 1.2 x 3.2mm |
| 449MAZ-150R | 56637 | 0-150mm | 63.5mm | 6 | |
| 449MBZ-75R | 56638 | 0-75mm | 100mm | 3 | |
| 449MBZ-150R | 56639 | 0-150mm | 100mm | 6 | |

Rods Only for 449M Micrometer Depth Gages

| For 449 (in) | | | For 449M (mm) | | |
|--------------|-------|------|---------------|-------|-----------|
| Part No. | EDP | Size | Part No. | EDP | Size |
| PT99306 | 72476 | 0-1" | PT99115 | 71838 | 0-25mm |
| PT99307 | 72477 | 1-2" | PT99116 | 71839 | 25-50mm |
| PT99308 | 72478 | 2-3" | PT99117 | 71840 | 50-75mm |
| PT99309 | 72479 | 3-4" | PT99118 | 71841 | 75-100mm |
| PT99310 | 72480 | 4-5" | PT99119 | 71842 | 100-125mm |
| PT99311 | 72481 | 5-6" | PT99120 | 71843 | 125-150mm |

Longer rods are available by special order.



449AZ-3R



DEPTH MICROMETERS

440, 445 DEPTH MICROMETERS

0-9" AND 0-12"/0-225MM

- The depths of holes, slots, shoulders and projections can be measured to .001" or 0.01mm with these fine tools
- 440 Gages furnished with a 2-1/2" (63.5mm) base and 1/8" (3.2mm) diameter measuring rods
- 445 Gages furnished with choices of 3" (75mm), 4" (100mm), and 6" (150mm) bases and have 5/32" (4mm) diameter measuring rods
- Combination ratchet and speeder for uniform pressure and quicker adjustment
- Ring-type lock nut for quick and sure locking



445AZ-6RL



440-3L



445AZRL

440, 445 Depth Micrometers

| Cat. No. | EDP | Range | Base | Rods | Rod Dia. |
|------------|-------|-------|--------|------|----------|
| 440Z-3L | 52113 | 0-3" | | 3 | |
| 440Z-6L | 52117 | 0-6" | 2-1/2" | 6 | 1/8" |
| 440Z-9L | 52121 | 0-9" | | 9 | |
| 440Z-3RL | 52115 | 0-3" | | 3 | |
| 440Z-6RL | 52119 | 0-6" | 2-1/2" | 6 | 1/8" |
| 440Z-9RL | 52123 | 0-9" | | 9 | |
| 445AZ-3RL | 52208 | 0-3" | | 3 | |
| 445AZ-6RL | 52212 | 0-6" | 3" | 6 | 5/32" |
| 445AZ-9RL | 52216 | 0-9" | | 9 | |
| 445AZ-12RL | 67117 | 0-12" | | 12 | |
| 445BZ-3RL | 52220 | 0-3" | | 3 | |
| 445BZ-6RL | 52224 | 0-6" | 4" | 6 | 5/32" |
| 445BZ-9RL | 52228 | 0-9" | | 9 | |
| 445BZ-12RL | 67118 | 0-12" | | 12 | |
| 445DZ-3RL | 52244 | 0-3" | | 3 | |
| 445DZ-6RL | 52248 | 0-6" | 6" | 6 | 5/32" |
| 445DZ-9RL | 52252 | 0-9" | | 9 | |
| 445DZ-12RL | 67119 | 0-12" | | 12 | |

440M, 445M Depth Micrometers

| Cat. No. | EDP | Range | Base | Rods | Rod Dia. |
|--------------|-------|---------|--------|------|----------|
| 440MZ-75RL | 52116 | 0-75mm | | 3 | |
| 440MZ-150RL | 52120 | 0-150mm | 63.5mm | 6 | 3.2mm |
| 440MZ-225RL | 52124 | 0-225mm | | 9 | |
| 445MAZ-75RL | 52209 | 0-75mm | | 3 | |
| 445MAZ-150RL | 52213 | 0-150mm | 75mm | 6 | 4mm |
| 445MAZ-225RL | 52217 | 0-225mm | | 9 | |
| 445MBZ-75RL | 52221 | 0-75mm | | 3 | |
| 445MBZ-150RL | 52225 | 0-150mm | 100mm | 6 | 4mm |
| 445MBZ-225RL | 52229 | 0-225mm | | 9 | |
| 445MDZ-75RL | 52245 | 0-75mm | | 3 | |
| 445MDZ-150RL | 52249 | 0-150mm | 150mm | 6 | 4mm |
| 445MDZ-225RL | 52253 | 0-225mm | | 9 | |

Inch Reading Rods Only

| Fits 440 Models | | Fits 445 Models | | Size |
|-----------------|-------|-----------------|-------|--------|
| Part No. | EDP | Part No. | EDP | |
| PT99331 | 71973 | PT99341 | 71982 | 0-1" |
| PT99332 | 71974 | PT99342 | 71983 | 1-2" |
| PT99333 | 71975 | PT99343 | 71984 | 2-3" |
| PT99334 | 71976 | PT99344 | 71985 | 3-4" |
| PT99335 | 71977 | PT99345 | 71986 | 4-5" |
| PT99336 | 71978 | PT99346 | 71987 | 5-6" |
| PT99337 | 71979 | PT99347 | 71988 | 6-7" |
| PT99338 | 71980 | PT99348 | 71989 | 7-8" |
| PT99339 | 71981 | PT99349 | 71990 | 8-9" |
| | | PT99358 | 66673 | 9-10" |
| | | PT99359 | 66674 | 10-11" |
| | | PT99360 | 66675 | 11-12" |

Millimeter Reading Rods Only

| Fits 440M Models | | Fits 445M Models | | Size |
|------------------|-------|------------------|-------|-----------|
| Part No. | EDP | Part No. | EDP | |
| PT99361 | 72193 | PT99371 | 72202 | 0-25mm |
| PT99362 | 72194 | PT99372 | 72203 | 25-50mm |
| PT99363 | 72195 | PT99373 | 72204 | 50-75mm |
| PT99364 | 72196 | PT99374 | 72205 | 75-100mm |
| PT99365 | 72197 | PT99375 | 72206 | 100-125mm |
| PT99366 | 72198 | PT99376 | 72207 | 125-150mm |
| PT99367 | 72199 | PT99377 | 72208 | 150-175mm |
| PT99368 | 72200 | PT99378 | 72209 | 175-200mm |
| PT99369 | 72201 | PT99379 | 72210 | 200-225mm |

Longer rods available by special order.

DEPTH MICROMETERS

443 MICROMETER DEPTH GAGES WITH HALF BASE

0-9"

- Exactly like the 445 Micrometer except that it has a half base
- 2" (50mm) half base permits measuring depths of holes and slots close to shoulders and between obstructions
- Rods have individual length adjustment and are 5/32" (4mm) in diameter

| 443 Micrometer Depth Gages | | | | |
|----------------------------|-------|-------|-------------|------------|
| Cat. No. | EDP | Range | No. of Rods | Graduation |
| 443Z-3RL | 52171 | 0-3" | 3 | |
| 443Z-6RL | 52173 | 0-6" | 6 | .001" |
| 443Z-9RL | 52175 | 0-9" | 9 | |

| Inch Reading Rods Only | | |
|------------------------|-------|--------|
| 443 Models | | |
| Part No. | EDP | Size |
| PT99341 | 71982 | 0-1" |
| PT99342 | 71983 | 1-2" |
| PT99343 | 71984 | 2-3" |
| PT99344 | 71985 | 3-4" |
| PT99345 | 71986 | 4-5" |
| PT99346 | 71987 | 5-6" |
| PT99347 | 71988 | 6-7" |
| PT99348 | 71989 | 7-8" |
| PT99349 | 71990 | 8-9" |
| PT99358 | 66673 | 9-10" |
| PT99359 | 66674 | 10-11" |
| PT99360 | 66675 | 11-12" |



690

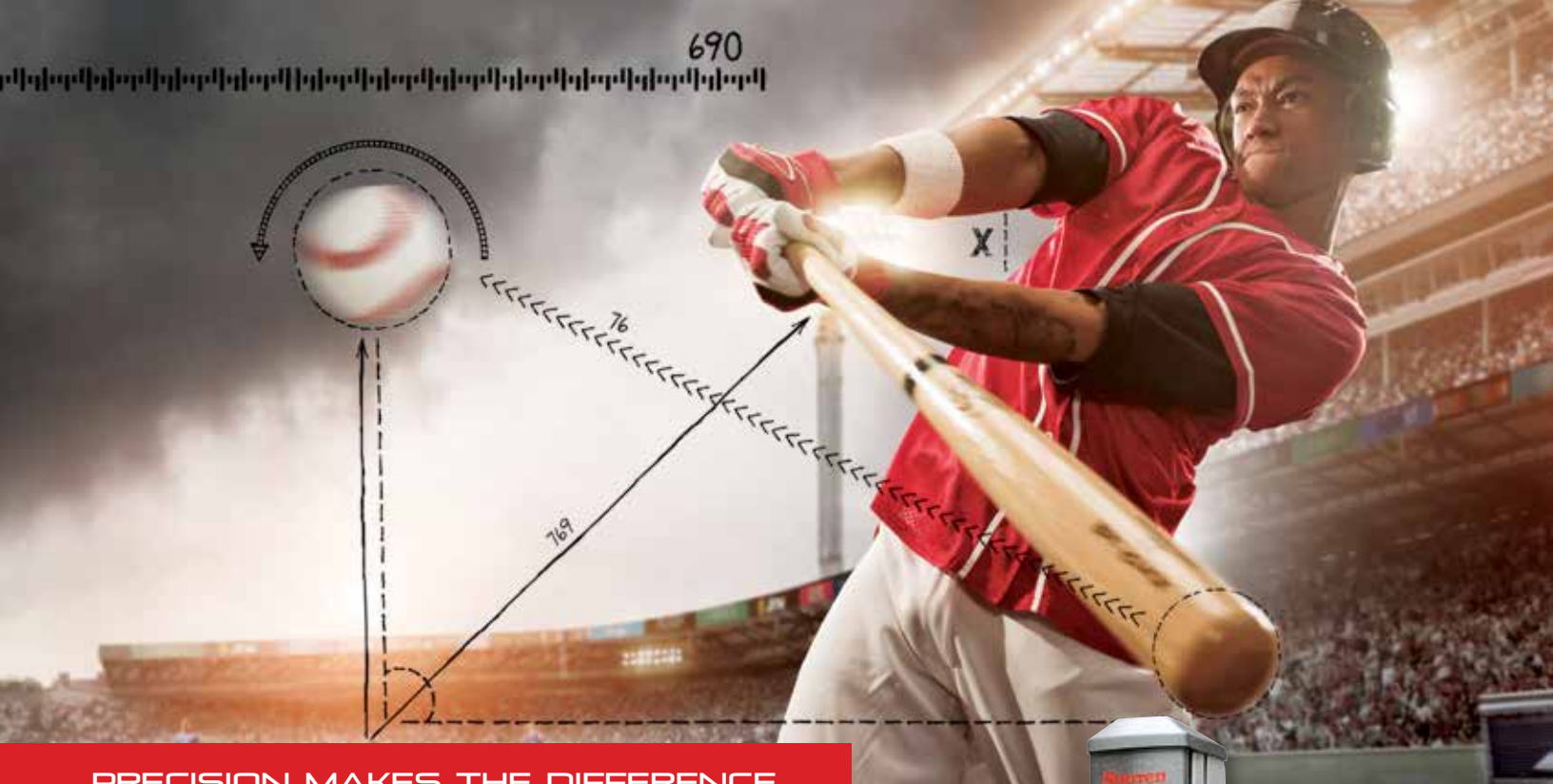

PRECISION MAKES THE DIFFERENCE

EXCEED YOUR CAPABILITIES.

The Starrett FMS incorporates new performance-based capabilities and user-friendly features to help you perform critical force tests with greater accuracy and efficiency.

It can perform all of your basic force measurement tests, as well as more complex multi-stage tests to international standards.



Model FMS5000

Starrett®

(978) 249-3551 • starrett.com

Follow us!





SLIDE CALIPERS

ELECTRONIC CALIPERS

798 ELECTRONIC CALIPERS

0-12"/0-300MM

The 798 Electronic Caliper features a large, easy-to-read, high contrast LCD readout. It includes IP67 protection against coolants, water, chips, dust and dirt often found in machine shop environments. Its induction type linear encoder system and Inch/millimeter conversion makes Starrett precision measuring tools the right choice for any job.

| 798 Electronic Calipers | | | |
|-------------------------|-------|---------------|------------------------|
| Cat. No. | EDP | Range | Description |
| 798B-6/150 | 12521 | 0-6" (150mm) | Caliper with output |
| 798B-6/150 W/SLC | 12522 | | Caliper with output |
| 798BX-6/150 | 12782 | | Caliper with output |
| 798A-6/150 | 20798 | | Caliper without output |
| 798B-8/200 | 12523 | 0-8" (200mm) | Caliper with output |
| 798B-8/200 W/SLC | 12524 | | Caliper with output |
| 798A-8/200 | 20799 | | Caliper without output |
| 798B-12/300 | 12525 | | Caliper with output |
| 798B-12/300 W/SLC | 12526 | 0-12" (300mm) | Caliper with output |
| 798A-12/300 | 20800 | | Caliper without output |

Accessories, Cables and Case Information for 798 Electronic Calipers

| Cat. No. | EDP | Description |
|-----------------|-------|--|
| 798SCM | 69894 | SmartCable to multiplexer |
| 798SCU | 73321 | SmartCable to USB |
| 798SCKB | 69889 | USB cable to PC (In focused window) |
| PT26151 | 64440 | Center distance attachment |
| PT22431 | 64640 | Depth attachment |
| PT63388 | 72517 | Computer interface cable to PC (USB) with driver CD |
| PT63329-1 | 12733 | Replacement non-contact computer interface cable to PC (USB) |
| PT99492 | 65650 | Two 3-Volt batteries, CR2032 |
| 723ZZ-6/722ZZ-6 | 57070 | Deluxe padded case for 0-6" (150mm) calipers |
| 950 | 63878 | Finished wood case for 0-8" (200mm) calipers |
| 946 | 56695 | Finished wood case for 0-12" (300mm) calipers |

*Includes redemption card for Standard Letter of Certification (SLC).



FEATURES

- IP67 level of protection
- Fine adjustment
- Hardened stainless steel measuring surfaces
- Large, easy-to-read, high-contrast LCD digital readout
- Induction type linear encoder system
- RS232 output
- Heavy-duty bar and slide
- Slide lock
- One 3-volt battery for over one year of normal usage
- In/mm conversion
- Zero at any position
- Auto-Off after 30 minutes
- Reactivation of display with no loss of position
- Works well with Starrett DataSure® Wireless Data Collection Systems

Approximate Jaw Depths for 798 Electronic Calipers

| | 6" (150mm) | 8" (200mm) | 12" (300mm) |
|---------|---------------|-----------------|-----------------|
| Outside | 1-1/2" (38mm) | 1-7/8" (47.6mm) | 2-1/2" (63.5mm) |
| Inside | 5/8" (16mm) | 3/4" (19mm) | 3/4" (19mm) |



IP PROTECTION

An IP number is composed of two numbers, the first referring to protection against solid objects and the second against liquids.

First number 6: Totally protected against dust

Second number 7: Protection against submersion in water under standardized conditions of pressure for 30 minutes



ELECTRONIC CALIPERS

NEW!

EC799 ELECTRONIC CALIPERS

0-40"/0-1000MM

The EC799 Electronic Caliper is light, comfortable, easy-to-use, and constructed with features that have made Starrett slide calipers the machinist's first choice for many years. Output now available.

The EC799 offers a slim, streamlined profile, a large, clear, easy-to-read LCD display, long battery life, and function buttons for zero and inch/mm.

FEATURES

- Lightweight, ergonomic design
- Inch/millimeter conversion reads .0005" or 0.01mm
- Easy access to the single, long-life battery
- Last measuring position retained when shut off
- Hardened stainless steel body for long life
- Fine adjustment thumb wheel
- Lock screw to hold the slide in position
- Resolution is .0005" (0.01mm)
- Zero at any position
- Protective case

6", 8" AND 12" CALIPERS ONLY

- Large easy-to-read LCD, .32" high characters
- Automatic shut-off after 5 minutes of non-use
- Linear accuracy meets DIN862
- Integrated depth rod

EXTENDED RANGE 24" AND 40" CALIPERS

- Preset and hold feature
- Minimum and maximum limits set
- I.D. jaw dimension is 0.800"/20.32mm
- LCD characters are .50" high
- Auto shut-off after 30 minutes of non-use

SLIDE CALIPERS

EC799 Electronic Slide Calipers

| Cat. No. | EDP | Range | |
|----------------------|-------|-------|-------|
| | | in | mm |
| EC799A-6/150 | 00142 | 0-6 | 0-150 |
| EC799A-6/150 W/SLC* | 72665 | | |
| EC799B-6/150 | 00143 | | |
| EC799B-6/150 W/SLC* | 00144 | | |
| EC799A-8/200 | 00145 | 0-8 | 0-200 |
| EC799A-8/200 W/SLC* | 72674 | | |
| EC799B-8/200 | 00146 | | |
| EC799B-8/200 W/SLC* | 00147 | | |
| EC799A-12/300 | 00148 | 0-12 | 0-300 |
| EC799A-12/300 W/SLC* | 72673 | | |
| EC799B-12/300 | 00149 | | |
| EC799B-12/300 W/SLC* | 00150 | | |

799 Extended Slide Calipers

| Cat. No. | EDP | Range | |
|---------------|-------|-------|--------|
| | | in | mm |
| 799AZ-24/600 | 11978 | 0-24 | 0-600 |
| 799AZ-40/1000 | 11979 | 0-40 | 0-1000 |

Accessories, Cables and Case Information for 799 Electronic Calipers

| Cat. No. | EDP | Description |
|-----------------|-------|--|
| EC799BSCM | 46000 | SmartCable to multiplexer |
| EC799BSCU | 46002 | SmartCable to USB |
| EC799BSCKB | 46001 | SmartCable to USB keyboard |
| PT26151 | 64440 | Center distance attachment |
| PT22431 | 64640 | Depth attachment for 6", 9" and 150mm calipers |
| PT99492 | 65650 | 3-volt battery; CR2032 |
| 723ZZ-6/722ZZ-6 | 57070 | Deluxe padded case for 0-6" (150mm) calipers |
| 950 | 63878 | Finished wood case for 0-8" (200mm) calipers |
| 946 | 56695 | Finished wood case for 0-12" (300mm) calipers |

* Includes redemption card for Standard Letter of Certification (SLC).

Approximate Jaw Depths for 799 Electronic Calipers

| | 6" (150mm) | 8" (200mm) | 12" (300mm) | 24" (600mm) | 40" (1000mm) |
|---------|---------------|-------------|-----------------|------------------|------------------|
| Outside | 1-1/2" (38mm) | 2" (50.8mm) | 2-1/2" (63.5mm) | 4" (100mm) | 6" (150mm) |
| Inside | 5/8" (16mm) | 3/4" (19mm) | 23/32" (18.3mm) | 11/16" (17.46mm) | 11/16" (17.46mm) |



CARBON CALIPERS

5000, 5001 AND 5002 CARBON FIBER CALIPERS

0-40"

- Carbon fiber construction significantly reduces weight, improving maneuverability
- Titanium coated stainless steel outside measurement jaws for long life and superior flatness
- Coolant resistant
- Two preset modes, REF I and REF II, allow setting one mode to a setting master and a second to a zero setting
- Full-featured, sophisticated electronics with RS232 output
- Ideal for use with Starrett DataSure® Wireless Data Collection Systems using a 1500-3A-1N end node
- Will also transmit to PC through cable

FEATURES AND SPECIFICATIONS

- CR2032 lithium battery included
- Clamping screw
- Protective wooden case
- Resolution: 0.0005"/0.01mm

5000 AND 5002 ONLY

- mm/inch mode button
- On/Off button
- Hold feature will freeze the display when in REF I or REF II mode

5001 ONLY

- Mode and Set buttons
- Min/Max mode displays values referenced from the preset value of the REF mode the tool is in when entering MIN/MAX
- Tolerance mode to set upper and lower measurement tolerances
- Larger display with more information



5002BZ-16/400 with PT06138 Step Contacts



5002BZ-24/600 with PT06139 Conical Contacts



5002BZ-40/1000 with PT06137 Disc Contacts



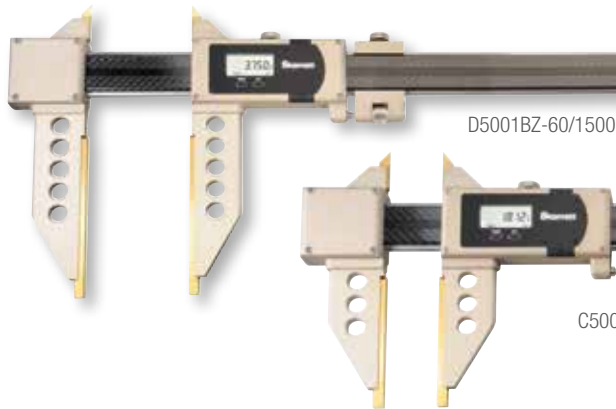
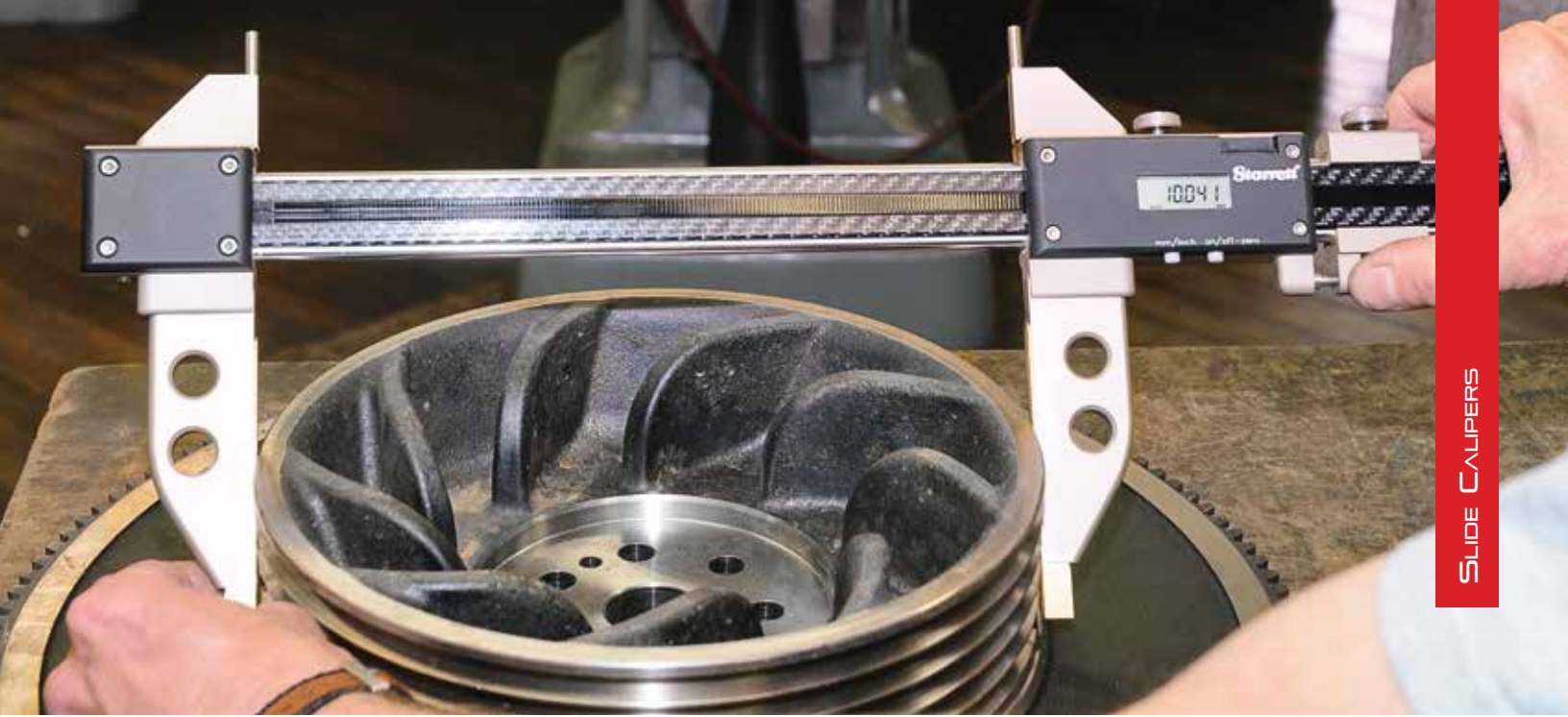

C5001BZ-40/1000



B5000BZ-24/600

B5000BZ-20/500

5000 Carbon Fiber Calipers

| Cat. No. | EDP | Outside | Weight | Jaw Depth | Measuring Capacities | |
|-----------------|-------|---------------------|--------------------|-------------------|--------------------------|--------------------------|
| | | | | | Inside (w/jaws) | Inside (w/top pins) |
| B5000BZ-20/500 | 14571 | 0-20" (0-500mm) | 2.43lb (1.10kg) | 4.921" (125mm) | 0.787-20" (20-500mm) | 0.394-20" (10-500mm) |
| B5000BZ-24/600 | 14572 | 0-24" (0-600mm) | 2.56lb (1.16kg) | 4.921" (125mm) | 0.787-24" (20-600mm) | 0.394-24" (10-600mm) |
| B5000BZ-40/1000 | 14573 | 0-40" (0-1000mm) | 3.09lb (1.40kg) | 4.921" (125mm) | 0.787-40" (20-1000mm) | 0.394-40" (10-1000mm) |

5001 Carbon Fiber Calipers

| Cat. No. | EDP | Outside | Weight | Jaw Depth |
|-----------------|-------|------------------|-----------------|----------------|
| C5001BZ-40/1000 | 14574 | 0-40" (0-1000mm) | 5.51lb (2.50kg) | 5.906" (150mm) |
| D5001BZ-60/1500 | 14575 | 0-60" (0-1500mm) | 7.28lb (3.30kg) | 7.875" (200mm) |

5002 Carbon Fiber Calipers

| Cat. No. | EDP | Outside | Weight |
|----------------|-------|------------------|-----------------|
| 5002BZ-16/400 | 14576 | 0-16" (0-400mm) | 1.65lb (0.75kg) |
| 5002BZ-24/600 | 14577 | 0-24" (0-600mm) | 1.98lb (0.90kg) |
| 5002BZ-40/1000 | 14578 | 0-40" (0-1000mm) | 3.31lb (1.50kg) |

Accessories for 5002 Carbon Fiber Calipers

| Part No. | EDP | Description |
|----------|-------|---------------|
| PT06137 | 12829 | Disc Contacts |
| PT06138 | 12830 | Step Contacts |
| PT06139 | 12831 | Cone Contacts |

Data Collection

| Part No. | EDP | Description |
|----------|-------|-------------------------------------|
| 797SCKB | 69890 | USB cable to PC (In focused window) |





ELECTRONIC CALIPERS

5005 ELECTRONIC LONG JAW CALIPERS

0-24"/0-600MM

The 5005 Electronic Calipers are built with extra long, 12" (300mm) jaws ideal for applications requiring precise O.D. or I.D. measurement in tight spaces that standard calipers can not reach.

FEATURES AND SPECIFICATIONS

- Hardened stainless steel construction for long life
- Tight, smoothly fitted slides for maximum accuracy and easy adjustment
- Coolant resistant
- Lock nut to hold measurements
- Fine adjustment thumbwheel
- Inch/mm conversion
- Ability to set ZERO at any position
- Two preset modes to install any reading at any point
- Full-featured, sophisticated electronics with Opto RS232 output
- Ideal for use with Starrett DataSure® Wireless Data Collection Systems using a 1500-3A-1N end node
- Will also transmit to PC through cable
- CR2032 lithium battery included
- Large easy-to-read display with resolution of 0.0005"/0.01mm
- Packed in a wood case
- Computers with Excel use 797SCKB
- Computers running SPC Data Collection use 797SCU

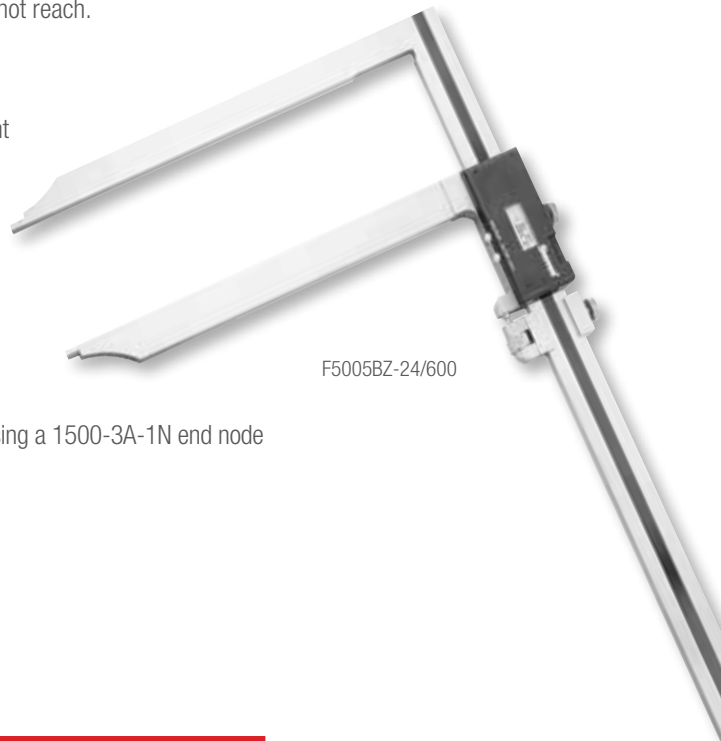

F5005BZ-24/600

5005 Electronic Calipers

| Cat. No. | EDP | Range | Jaw Depth |
|----------------|-------|-----------------|-------------|
| F5005BZ-24/600 | 14588 | 0-24" (0-600mm) | 12" (300mm) |





ELECTRONIC CALIPERS

5006 ELECTRONIC GROOVE CALIPERS

FEATURES AND SPECIFICATIONS

- Standard Measuring Tip Diameter: .118" (3mm)
- Two Preset Modes
- Hold Feature will freeze the display when it is in preset mode
- On/Off Button
- RS232 port allows data transmission thru a DataSure® Wireless Data Collection System using a 1500-3A-1N End Node. Will also transmit through a connected cable
- CR2032 lithium battery included
- Includes wooden case
- Resolution: 0.0005" (0.01 mm)
- Generous diameter and jaw depth capacities
- Ideal for measuring internal and external grooves on large workpieces
- Hardened stainless steel construction
- Coolant resistant



5006BZ-14/350

5006 Electronic Groove Caliper

| Cat. No. | EDP |
|---------------|-------|
| 5006BZ-14/350 | 14589 |

Data Collection

| Part No. | EDP | Description |
|----------|-------|-------------------------------------|
| 797SCKB | 69890 | USB cable to PC (In focused window) |

Specifications

| | Groove Measuring Range | Max. Depth |
|---------|------------------------|----------------|
| Outside | 0-12.5" (0-318mm) | 3.937" (100mm) |
| Inside | 1.654-15" (42-381mm) | 3.7" (94mm) |



DIAL CALIPERS

120, 120M DIAL CALIPERS

0-12"/0-300MM

The Only American Made Dial Caliper ...

This is one of the handiest measuring tools available, used by mechanics and toolmakers everywhere. It is direct reading, reliable and accurate.

READABILITY FEATURES

- Sharp, clear dial graduations of .001" or 0.02mm – .100" or 2mm in one revolution
- Sharp, black graduations on the satin finished bar, every .100" or 1mm
- Choice of black, red, or white inch dials; millimeter dials are yellow

EASE-OF-HANDLING FEATURES

- Knife-edge contacts for both inside and outside measurements
- One hand use with the thumb-operated, fine adjustment roll
- Lock screw for dial bezel and for holding the sliding jaw in position
- Detachable depth rod available for 12" (300mm) model
- Parallel lines can be scribed on a workpiece by setting the caliper jaw to the required dimensions, locking the movable jaw with the lock screw and then using the front edge of the fixed jaw as the scribing surface

ACCURACY AND LONG-LIFE FEATURES

- Long-wearing carbide faces on outside contacts on model 120AX-6 and 120MX-150 only
- Hardened stainless steel bar, measuring surfaces, rack, gears and depth rod
- Positive, split-gear anti-backlash control
- Rack teeth point down to make it easy to shed foreign matter and thereby keep the area clean



120A-6



R120A-6



B120A-6



120AM-150 metric dial caliper with yellow dial



120Z-12





120 Dial Calipers (.001" Graduation)

| Cat. No. | EDP | Range | Dial Color | Jaw Depth | | Description |
|----------------|-------|-------|------------|-----------|----|--------------------------------|
| | | | | in | mm | |
| 120A-6 | 64514 | 0-6" | White | 5/8 | 16 | Caliper in fitted plastic case |
| 120A-6 W/SLC† | 66568 | | | | | Caliper in fitted plastic case |
| 120X-6 | 65909 | 0-6" | White | 1-1/2 | 38 | Caliper in fitted plastic case |
| B120A-6 | 64515 | 0-6" | Black | 5/8 | 16 | Caliper in fitted plastic case |
| B120A-6 W/SLC† | 66917 | 0-6" | Black | 1-1/2 | 38 | Caliper in fitted plastic case |
| R120A-6 | 64516 | 0-6" | Red | 5/8 | 16 | Caliper in fitted plastic case |
| R120A-6 W/SLC† | 66918 | 0-6" | Red | 3/4 | 19 | Caliper in fitted plastic case |
| 120AZ-9 | 64520 | 0-9" | White | 5/8 | 16 | Caliper in finished Wood case |
| 120A-9 | 64517 | 0-9" | White | 1-1/2 | 38 | Caliper without case |
| 120Z-12 | 56693 | | | | | Caliper in finished wood case |
| 120Z-12 W/SLC† | 66569 | 0-12" | White | 3/4 | 19 | Caliper in finished wood case |
| 120-12 | 56694 | | | | | Caliper without case |
| 120-12 W/SLC† | 66919 | 0-12" | White | 2-1/2 | 63 | Caliper without case |

120M Dial Calipers (0.02mm Graduation)

| Cat. No. | EDP | Range | Dial Color | Jaw Depth | | Description |
|------------------|-------|---------|------------|-----------|----|--------------------------------|
| | | | | in | mm | |
| 120AM-150 | 66295 | 0-150mm | Yellow | | 16 | Caliper in fitted plastic case |
| 120AM-150 W/SLC† | 66920 | | | | | Caliper, without case |
| 120MX-150 | 65910 | 0-150mm | Yellow | | 38 | Caliper in fitted plastic case |
| 120MZ-225 | 64508 | 0-225mm | Yellow | | 16 | Caliper in wood case |
| 120M-225 | 64509 | 0-225mm | Yellow | | 38 | Caliper without case |
| 120MZ-300 | 64510 | | | | | Caliper in wood case |
| 120MZ-300 W/SLC† | 66922 | 0-300mm | Yellow | | 19 | Caliper in wood case |
| 120M-300 | 64511 | | | | | Caliper without case |
| 120M-300 W/SLC† | 66921 | 0-300mm | Yellow | | 63 | Caliper without case |

Accessories and Cases Only for 120 and 120M Dial Calipers

| Cat. No. | EDP | Description |
|----------|-------|--|
| PT26151 | 64440 | Center distance attachment* |
| PT22431 | 64640 | Depth attachment for 6", 9" and 150mm calipers |
| PT26091 | 65100 | Detachable depth rod for 12" calipers |
| 943 | 55971 | Deluxe padded case for 6" (150mm) calipers |
| 950 | 63878 | Finished wood case for 9" (225mm) calipers |
| 946 | 56695 | Finished wood case for 12" (300mm) calipers |
| 915 | 64166 | Leather holster for 6" (150mm) calipers |

† Includes redemption card for Standard Letter of Certification (SLC).

* See details in this section.



NEW!

SLIDE CALIPERS

DIAL CALIPERS

3202 DIAL CALIPERS

0-12"

With the ability to provide quick, accurate measurement of O.D., I.D., depth and step the dial caliper is the most versatile precision hand tool on the market.

3202 Dial Calipers are based on the caliper that has been the first choice of metal working professionals for decades. 3202 Dial Calipers are available in 6", 8" and 12" versions.

FEATURES AND SPECIFICATIONS

- Sharp, clear dial graduations of 0.001"
- 1" per revolution
- Thumb-operated fine adjustment roll
- Sharp, black graduations on the satin finished bar, every .1"
- Hardened stainless steel bar, measuring surfaces, rack, gears, and depth rod
- Positive, spring-loaded double pinion anti-backlash control
- Lock screws for sliding jaw and dial bezel
- Knife-edge contacts
- Adjustable bezel
- 0-6", 0-8" and 0-12" sizes available

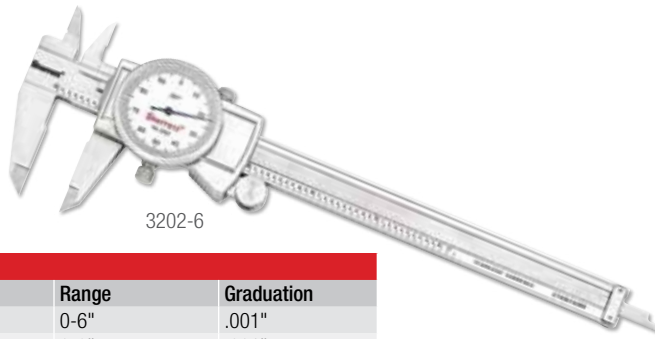

3202-6

3202 Dial Calipers

| Cat. No. | EDP | Range | Graduation |
|----------|-------|-------|------------|
| 3202-6 | 61467 | 0-6" | .001" |
| 3202-8 | 61468 | 0-8" | .001" |
| 3202-12 | 61466 | 0-12" | .001" |

1202F FRACTIONAL DIAL CALIPERS

0-12"

The 1202F shows measurements as fractions on the yellow outer scale with 1/64th inch graduations, and decimal measurements on the white inner scale with 1/100th inch graduations.

FEATURES

- 1/64" graduations on the yellow outer scale, and .01" on the white inner scale.
- Except for dial graduation and color, 1202F Calipers have the same features as other 1202 Dial Calipers



1202F-6

1202F Dial Calipers

| Cat. No. | EDP | Range |
|----------|-------|-----------------|
| 1202F-6 | 68931 | 0-6" Fractional |



DIAL CALIPERS

120B, 120MB DIAL CALIPERS WITH LONG NIB JAWS

0-12"/0-300MM

This tool is a direct reading caliper with 3" (75mm) long jaws, ideal for heavy duty use and for gaining access to more measuring area than with conventional calipers. Strong inside and outside nibs measuring from zero for outside measuring and from .300" or 8mm for inside measuring.



120B-12

| 120B and 120MB Dial Calipers with Long Nib Jaws | | | |
|---|-------|---------|------------|
| Cat. No. | EDP | Range | Dial Color |
| 120B-12 | 65067 | 0-12" | White |
| 120MB-300 | 65154 | 0-300mm | Yellow |
| 120MB-300 W/SLC* | 66923 | | |

* Includes redemption card for Standard Letter of Certification (SLC).

120J OFFSET DIAL CALIPER

0-6"

This tool has an adjustable jaw for versatility when measuring different planes that can't be reached with a regular caliper. The reference jaw is adjustable in height to be either longer or shorter than the sliding jaw. All other features are the same as our 120 Dial Caliper.

- Adjustable jaw – 3-1/2" (88mm) long
- Extends up to 5/8" (16mm) longer than the sliding jaws
- Caliper in deluxe padded case



120JZ-6

| 120J 0-6" Offset Dial Caliper | |
|-------------------------------|-------|
| Cat. No. | EDP |
| 120JZ-6 | 65866 |

CENTER DISTANCE ATTACHMENT

PT26151

A set of two jaws with body sizes of .400" and conical points, enabling the user to measure the center distance between holes or center-punched locations that are at least .400" apart and less than .400" in diameter.

- Can be used with metric calipers by setting the caliper to 10.16mm
- Will fit Starrett 797, 798 and 120, 6" through 12", 123, 6" through 24", and 1202, 4" through 12" sizes, and 799 6" and 8" sizes

| Center Distance Attachment | |
|----------------------------|-------|
| Cat. No. | EDP |
| PT26151 | 64440 |



PT26151



VERNIER CALIPERS

123, 123M, 123EM MASTER VERNIER CALIPERS

0-72" AND 0-24"/0-600MM

Ultimate example of slide caliper design. It is more accurate, has the easiest reading vernier style, is stronger and offered in much longer lengths than other slide calipers.

READABILITY FEATURES

- Long 50-division vernier scales permit half as many bar graduations as conventional single-vernier tools. These widely-spaced graduations make it easy to read to .001" or 0.02mm
- The open-face design of the slide allows both the inside and outside vernier scale on the same side, thus allowing both verniers to be read without turning the tool over
- Black lines and figures against the Starrett satin chrome finish make reading a pleasure, not an effort
- Screw-type adjusting nut allows for fine measuring adjustments and lock nut holds measurements

LONG-LIFE AND ACCURACY FEATURES

- Fine tool steel construction makes the jaws harder and longer-wearing than stainless tools. All tools through 24" (600mm) also have hardened and stabilized bars.
- Hardened, ground and lapped measuring surfaces
- Machine divided graduations for accuracy
- The combination straight and angular ways on the master bar allow for positive alignment of graduations and easy adjustment of the flush-fitting verniers
- Sizes through 24" have divider points on the back side to accurately set dividers and trammels
- Tools with inch and millimeter graduations on the same bar have outside readings only. (Inside readings must be compensated for by adding the nib width to the indicated reading.)
- The longer length of the adjusting jaw slide provides a longer bearing surface on the master bar, ensuring squareness with the solid jaw and extra resistance to springing
- Tight, smoothly fitted slides for maximum accuracy and easy adjustment
- Fitted wood case option

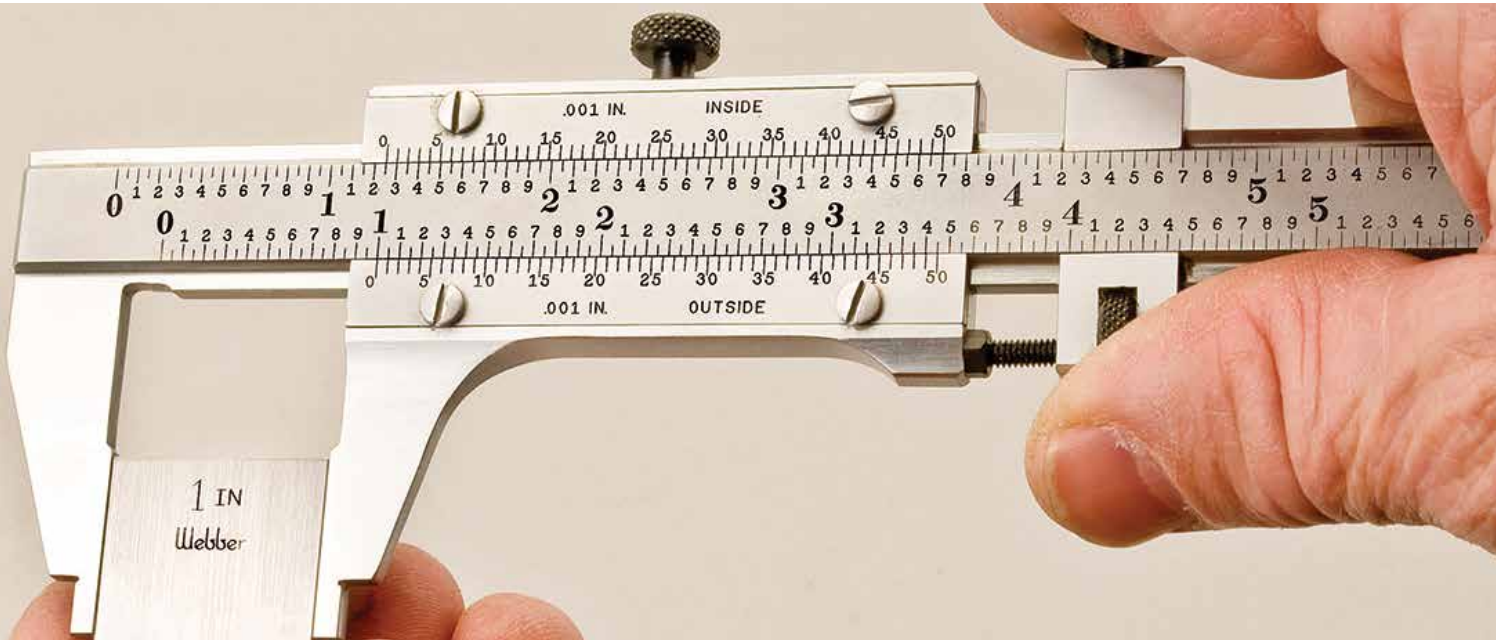
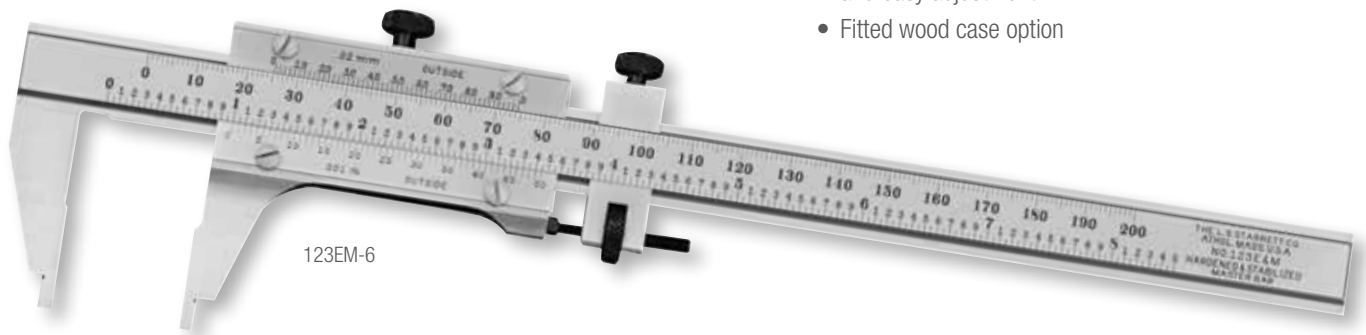

123 Master Vernier Calipers (.001" Graduation)

| Cat. No. | EDP | Range | Bar Width | Approx. Jaw Depth | Max. Nib Width Closed |
|----------------|-------|-------|-----------|-------------------|-----------------------|
| 123Z-6 | 50524 | 0-6" | 11/16" | 1-9/16" | .250" |
| 123Z-6 W/SLC* | 66925 | | | | |
| 123-6 | 50525 | | | | |
| 123Z-12 | 50526 | 0-12" | 15/16" | 2-5/16" | .300" |
| 123Z-12 W/SLC* | 66927 | | | | |
| 123-12 | 50527 | | | | |
| 123Z-24 | 50528 | 0-24" | 15/16" | 2-5/16" | .300" |
| 123Z-36 | 50530 | 0-36" | 1-3/8" | 3" | .500" |
| 123Z-48 | 50532 | 0-48" | 1-3/8" | 3" | .500" |
| 123Z-60 | 64383 | 0-60" | 2-1/2" | 4-1/2" | .750" |

123M Master Vernier Calipers (0.02mm Graduation)

| Cat. No. | EDP | Range | Bar Width | Approx. Jaw Depth | Max. Nib Width Closed |
|-----------|-------|---------|-----------|-------------------|-----------------------|
| 123M-150 | 56099 | 0-150mm | 17.46mm | 40mm | 6.4mm |
| 123MZ-300 | 56102 | 0-300mm | 23.81mm | 58mm | 7.6mm |
| 123M-300 | 56101 | | | | |
| 123MZ-600 | 56104 | 0-600mm | 23.81mm | 58mm | 7.6mm |

123EM Master Vernier Calipers (.001" and 0.02mm Graduation)

| Cat. No. | EDP | Range | Bar Width | Approx. Jaw Depth | Max. Nib Width Closed |
|-----------|-------|---------------|------------------|-------------------|-----------------------|
| 123EMZ-6 | 50534 | 0-6" (150mm) | 11/16" (17.46mm) | 1-9/16" (40mm) | .250" (6.35mm) |
| 123EM-6 | 50535 | | | | |
| 123EMZ-12 | 50536 | 0-12" (300mm) | 15/16" (23.81mm) | 2-5/16" (58mm) | .300" (7.62mm) |
| 123EM-12 | 50537 | | | | |
| 123EMZ-24 | 50538 | 0-24" (600mm) | 15/16" (23.81mm) | 2-5/16" (58mm) | .300" (7.62mm) |

For Inside Measurements on 123M and 123EM Master Vernier Calipers

| Cat. No. | Range | Add Nib Thickness Below to Caliper Reading |
|-------------|----------------|--|
| 123 E and M | 0-6" or 150mm | .250" (Inch) or 6.35mm (Metric) |
| 123 E and M | 0-12" or 300mm | .300" (Inch) or 7.62mm (Metric) |
| 123 E and M | 0-24" or 600mm | .300" (Inch) or 7.62mm (Metric) |

Other sizes available on special order – priced on application. Special jaws priced on application.
 Hardened Bars on 6", 12" and 24" models: these models are also furnished with center points for dividers.
 * Includes redemption card for Standard Letter of Certification (SLC).



123Z-6 with wooden case



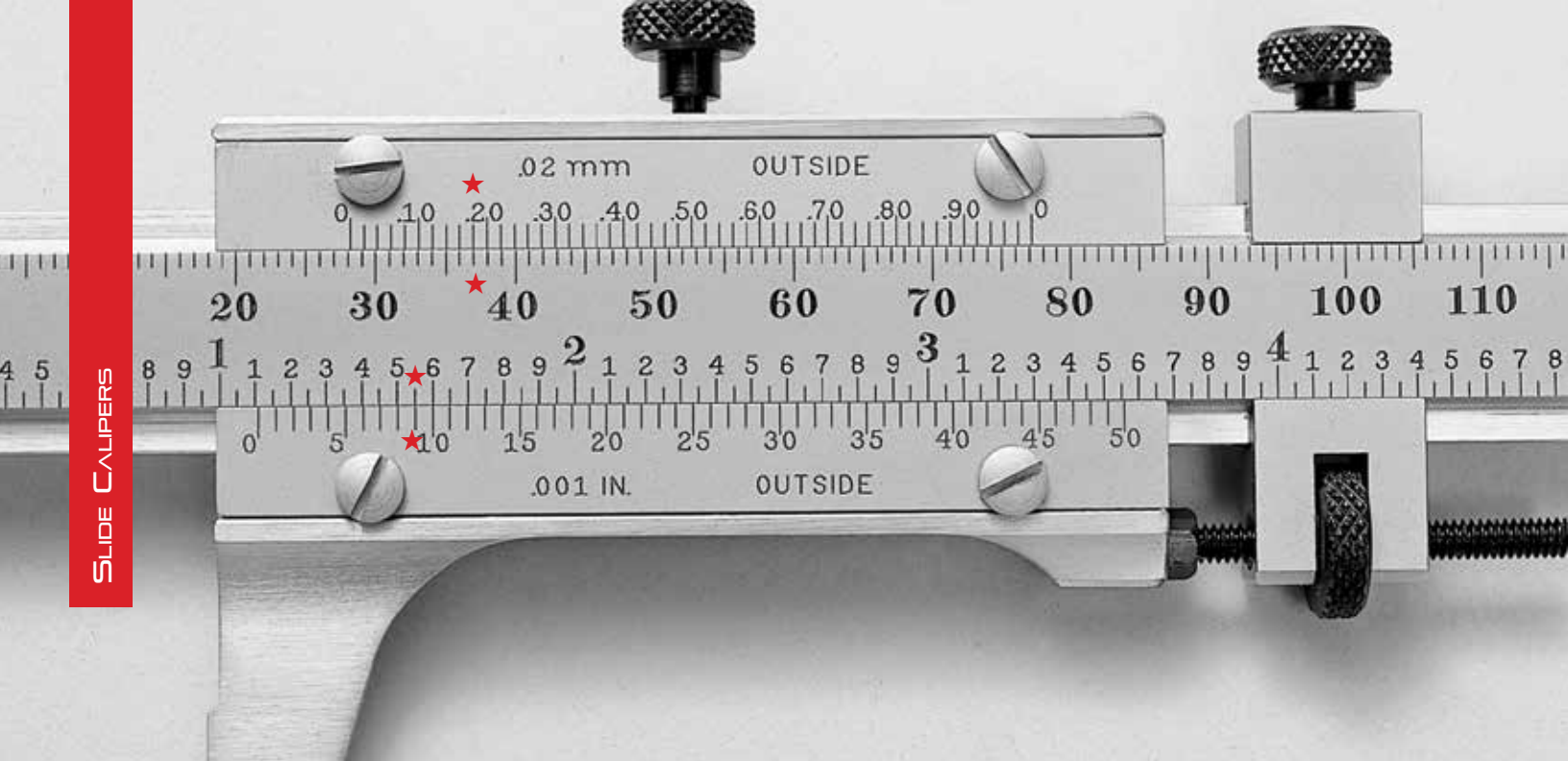

HOW TO READ A STARRETT 50-DIVISION VERNIER CALIPER GAGE

GRADUATED IN INCHES AND MILLIMETERS (DIRECT READING)

INCH READING

- Refer to the lower bar graduations and the inch vernier plate. Inches are numbered in sequence over the full range of the bar. Every second graduation between the inch lines is numbered and equals .100". Each bar graduation is .050"
- The vernier plate is divided into 50 parts, each representing .001". Every fifth line is numbered – 5, 10, 15, 20 ... 45, 50 – for easy counting
- To read the gage, first count how many inches and how many .050" lines lie between the zero line on the bar and the zero line on the vernier plate and add them
- Then count the number of graduations on the vernier plate from its zero line to the line that coincides with a line on the bar. Multiply the number of vernier plate graduations you counted by .001" and add this figure to the number of inches and .050" lines you counted on the bar. This is your total reading

EXAMPLE

- ★ In the photo, the vernier plate zero line is one inch (1.000") plus .100" beyond the zero line on the bar, or 1.100". The 9th graduation on the vernier plate coincides with a line on the bar (as indicated by stars). $9 \times .001"$ (.009") is therefore added to the 1.100" bar reading, and the total reading is 1.109"

MILLIMETER READING

- Refer to the upper bar graduations and millimeter vernier plate. Each bar graduation is 1.00mm. Every tenth graduation is numbered in sequence – 10mm, 20mm, 30mm, 40mm, etc. – over the full range of the bar. This provides for direct reading in millimeters
- The vernier plate is divided into 50 parts, each representing 0.02mm. Every fifth line is numbered in sequence – 0.10mm, 0.20mm, 0.30mm ... 0.80mm, 0.90mm – providing for direct reading in hundredths of a millimeter
- To read the gage, first count how many millimeters lie between the zero line on the bar and the zero line on the vernier plate
- Then find the graduation on the vernier plate that coincides with a line on the bar and note its value in hundredths of a millimeter. Add the vernier plate reading in hundredths of a millimeter to the number of millimeters you counted on the bar. This is your total reading

EXAMPLE

- ★ In the photo, the vernier plate zero line is 28 millimeters beyond the zero line on the bar, and the 0.18mm graduation on the vernier plate coincides with a line on the bar (as indicated by stars). 0.18 millimeters is therefore added to the 28mm bar reading, and the total reading is 28.18 millimeters



VERNIER CALIPERS

125 VERNIER CALIPERS

0-12"/0-300MM

- High quality, basic vernier caliper that offers inch and metric measurement
- Lock screw for sliding jaw
- Hardened stainless steel depth rod
- Graduations: .001" inch, 0.020mm metric
- Sharp, black graduations on the satin finished bar
- Fitted plastic case

| 125 Vernier Calipers | | | |
|----------------------|-------|-------------|-------|
| Cat. No. | EDP | Range in | mm |
| 125MEA-6/150 | 61660 | 0-6 | 0-150 |
| 125MEA-8/200 | 61882 | 0-8 | 0-200 |
| 125MEA-12/300 | 61886 | 0-12 | 0-300 |



SLIDE CALIPERS

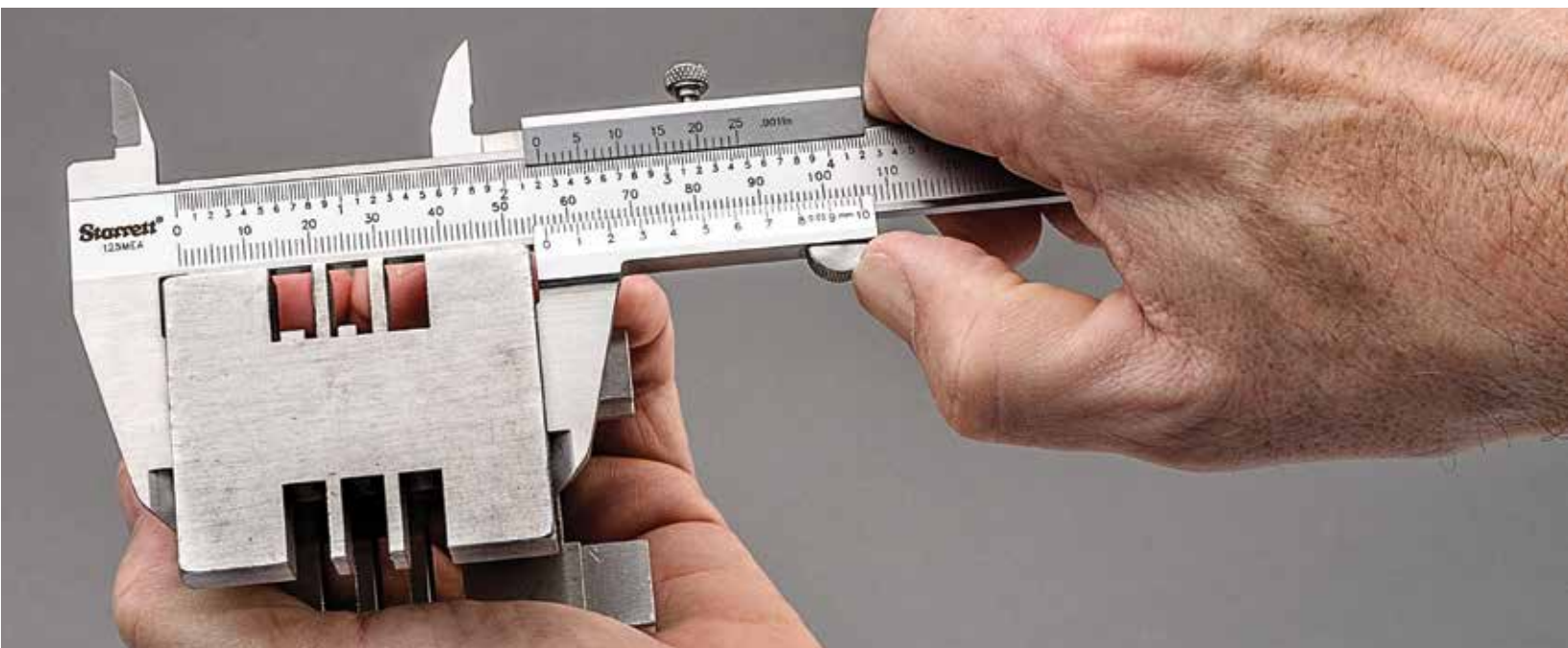

VERNIER CALIPERS

456 GEAR TOOTH VERNIER CALIPERS

20-2 DIAMETRAL PITCH

456M GEAR TOOTH VERNIER CALIPERS

1-1/4-25MM MODULE

The 456 Gear Tooth Vernier Caliper is designed to measure in .001" or 0.02mm the thickness of gear teeth at the pitch line (the chordal thickness of the teeth) using the distance from the top of a tooth to the chord. For the same purpose, it can also be used for measuring hobs, form and thread tools, etc.

The thickness of a tooth at the pitch line is measured by an adjustable jaw after the addendum is set by the adjustable tongue. Each of these is adjusted independently by screws on the graduated bars.

Graduation – .001"

| Cat. No. | EDP | Range |
|----------|-------|----------------------|
| 456AZ | 52420 | 20-2 Diametral Pitch |
| 456A | 52422 | |
| 456BZ | 52424 | 10-1 Diametral Pitch |
| 456B | 52426 | |

Graduation – 0.02mm

| Cat. No. | EDP | Range |
|----------|-------|-------------------|
| 456MAZ | 52421 | 1-1/4-12mm Module |
| 456MA | 52423 | |
| 456MBZ | 52425 | 2-1/2-25mm Module |
| 456MB | 52427 | |

Available with carbide measuring surfaces on special order. Available with attractive, protective case – sent with case unless otherwise ordered. Packed one in a box.

FOR TOOL OPERATION:

- Find on the chart, furnished with the tool, the number of teeth of the gear in question, and find the corrected addendum (s"). This figure is for one diametral pitch for inch measure, so divide it by the diametral pitch number – this figure is also for a one millimeter module for metric measure, so multiply it by the required module number. This gives a corrected addendum for this particular number of teeth.
- Next, measure the actual outside diameter of the gear and add or subtract one-half the difference between the theoretical gear diameter and actual measured gear diameter from the corrected addendum (s") found in the first step.
- Set the new calculated addendum figure on the adjustable tongue of the tool.
- Now, with the tongue on the top of the tooth, measure the chordal thickness with the horizontal vernier jaw and compare with the figure in the "t" column in the chart.
- All inch graduations are read to .001". However the 456A is graduated by .020" increments and the 456B is graduated by .025" increments. 456MA and 456MB are read to 0.02mm and graduated by 0.5mm increments.

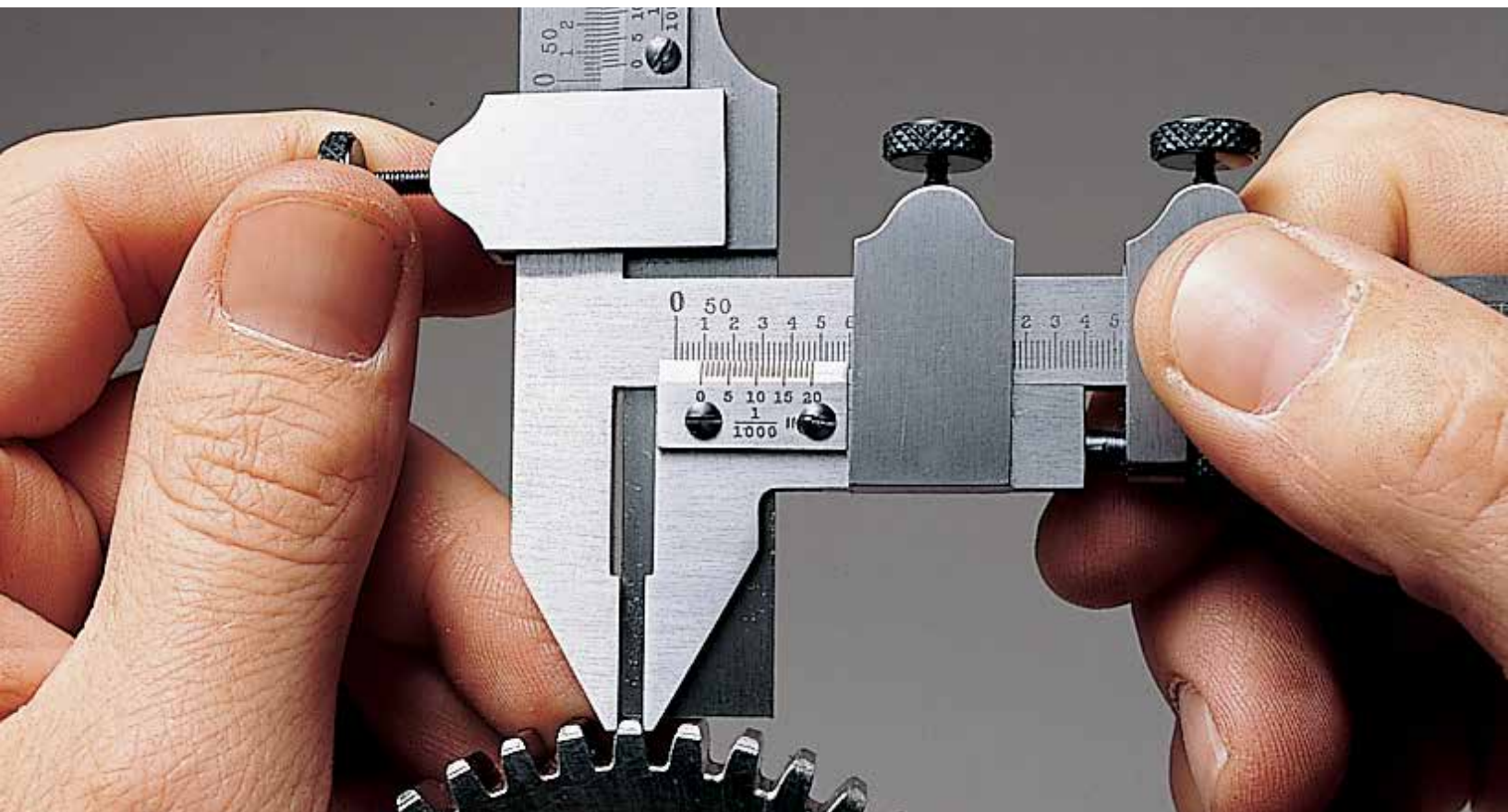

POCKET CALIPERS

1025, 1025ME STAINLESS STEEL POCKET SLIDE CALIPERS

INCH READING 5", 6"/INCH AND MILLIMETER READING 5"/130MM

These handy tools permit quick, accurate outside and inside measurements. Their compact size fits easily in shop coat pockets. Calipers are made of fine quality stainless steel.

- Readings are made directly from the two lines marked "in" and "out" on one side of the stock
- Handy inch or millimeter scale on the back of the stock
- Knurled thumb pieces to activate the slide and slide stop prevents tool from being disassembled
- Knurled clamp screw with a left hand thread for easy one-hand operation
- Straight measuring surface for outside measuring and rounded nibs for inside or hole measurements

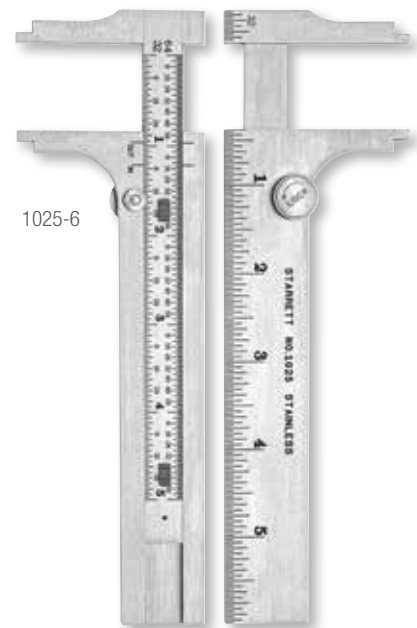

1025-6

SLIDE CALIPERS

1025 Stainless Steel Pocket Slide Calipers

| Cat. No. | EDP | Size | Range | | Depth of Jaws | Width of Nibs Closed | Graduations Slide | Stock |
|----------|-------|------|----------|--------|---------------|----------------------|-------------------|-------|
| | | | Outside | Inside | | | | |
| 1025-5 | 53123 | 5" | 0-3-3/4" | 1/4-4" | 1-3/8" | 1/4" | 32nds and 64ths | 32nds |
| 1025-6 | 53124 | 6" | 0-4-3/4" | 1/4-5" | 1-3/8" | 1/4" | 32nds and 64ths | 32nds |

1025ME Stainless Steel Pocket Slide Calipers

| Cat. No. | EDP | Size | Range | | Depth of Jaws | Width of Nibs Closed | Graduations Slide | Stock |
|------------|-------|---------------|----------------------|---------------------|-------------------|----------------------|-------------------|-------|
| | | | Outside | Inside | | | | |
| 1025ME-130 | 65860 | 5" (130mm) | 0-3-3/4" (0-96mm) | 1/4-4" (6-100mm) | 1-3/8" or 36mm | .236" or 6mm | 64ths and 1/2mm | mm |

Cases for 1025 and 1025ME Pocket Slide Calipers

| Cat. No. | EDP | Description |
|----------|-------|-------------------------|
| 1025ZZ-5 | 55269 | 5" and 130mm Vinyl Case |
| 1025ZZ-6 | 55270 | 6" Vinyl Case |

424 STAINLESS STEEL POCKET SLIDE CALIPERS

3-1/2"

This extremely handy caliper gives direct readings of both circumference and diameter in a single setting.

- Especially useful for obtaining instant circumference and diameter measurements of rope, cordage, metal rods, pipe, tubing, etc. and for checking cutting speeds on lathe work
- 1-3/8" deep jaws will caliper a cylinder up to 2-3/4" diameter
- The upper edge of the slide is graduated from 0 to 11 circumference inches in 16ths and the lower edge



424

424 Stainless Steel Pocket Slide Caliper and Circumference Gage

| Cat. No. | EDP | Size | Range | | Graduations | | Depth of Jaws |
|----------|-------|--------|----------|---------------|-------------|---------------|---------------|
| | | | Dia. | Circumference | Dia. | Circumference | |
| 424 | 51527 | 3-1/2" | 0-3-1/2" | 0-11" | 32nds | 16ths | 1-3/8" |

Cutting Speed in Feet per Minute = Circumference divided by 12 x Revolutions per Minute





PRECISION MAKES THE DIFFERENCE

GOES THE
DISTANCE.

Three major product lines to meet our customer's needs with performance and quality.



Starrett[®]

(978) 249-3551 • starrett.com

Follow us!





HEIGHT GAGES

ELECTRONIC HEIGHT GAGES

2000 ALTISSIMO® ELECTRONIC HEIGHT GAGES

0-24"/600MM

Altissimo® Electronic Height Gages are innovative, easy-to-use, and loaded with Starrett-exclusive functions for easy-to-program measuring routines that run smoothly and reliably.



FEATURES

- A unique, ergonomically shaped base, hardened and ground, that fits your grip just right to easily move the gage and press the hot key
- Hot key allows you to select measuring results on the fly
- 0-24" Measuring Range
- Smart probe that can measure I.D. or O.D. without attachments
- Electronically adjusted probe force
- Large, easy-to-read interactive LCD with unique scanning meter for monitoring probe position
- Electronically adjustable beeper volume
- Bold screen icons indicate the current routine
- Three electronically adjustable resolutions
- Retains the last calibrated diameter of the measuring probe, even after the gage is shut down
- Dynamic bi-directional probing with point and scan modes
- Easy operation with speed wheel, which also has fine-adjust feature
- Locking mechanism for scribing
- Five measurement modes: (ID/OD, Center, TIR, Max/Min, Continuous Display)
- Instant inch/millimeter conversion
- Two selectable Datums and Presets
- Auto Power Off after two hours with retention of probe calibration
- Automatic calculation of eight measurement routines:
 - Center
 - Diameter
 - Height
 - Max
 - Min
 - TIR
 - Distance to last feature
 - Distance between last two points
- Rechargeable NiMH batteries with 100 hours of continuous life
- Seven setup functions:
 - Probe Calibration (2)
 - Beeper Volume
 - Display Resolution
 - Probe Force Adjustment
 - Printer On/Off
 - Force Calibration
- Optional probe kit features a variety of probes for many applications
- Gages include carbide probe, probe holder and probe calibration block
- RS232 data output port
- Starrett capacitive measurement system ensures the accuracy and reliability you expect
- Excellent value – loaded with features and competitively priced



Large, easy-to-view /understand display shows the diameter of a hole or boss



Display showing TIR



Interactive LCD with unique scanning meter for easy probe position viewing

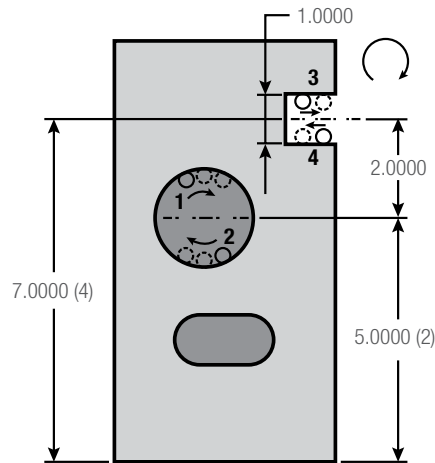

Altissimo includes many routines including diameter of a bore (1 and 2), width of a slot or a rib (3 and 4), distance from datum to center of a hole or slot and distance between features

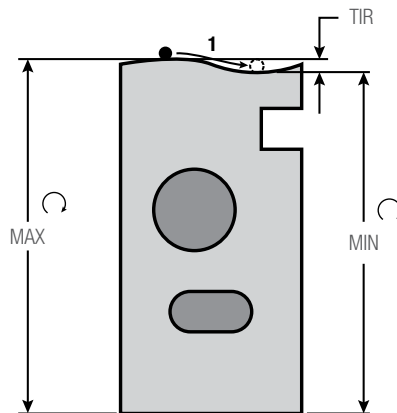

TIR mode can measure the high or low point of a diameter or other surface. The datum can then be set to the max or min value.

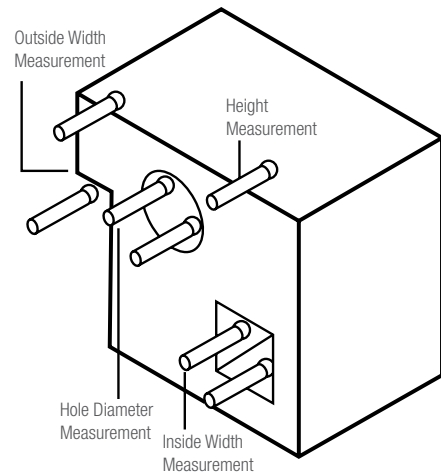

| Specifications | |
|-------------------------|---|
| Measuring Range | 24"/600mm (Extendible to 30"/750mm by rotating the probe holder 180°) |
| Resolution | .0001"/.0005"/.001" (0.002mm/0.01mm/0.02mm) |
| Accuracy | ±.0003" (0.008mm) |
| Repeatability | ±.0002" (±0.002mm) |
| Power Source | NiMH Rechargeable Batteries (120V AC/60Hz Charger/Adapter included). Operation time: 100+ hours, Recharging time: 10 hours |
| Included | .1875"/4.8mm Dia. Carbide Probe, Probe Holder |
| Accessories | AC Charger/Adapter, Probe Calibration Block |
| Dimensions | Length 11" (279mm), Width 7-3/4" (197mm), Height 36-1/2" (927mm) |
| Weight | 40 lb (18 kg) |
| Perpendicularity | .0004" (0.010mm) |



ELECTRONIC HEIGHT GAGES

ALTISSIMO® ELECTRONIC HEIGHT GAGES



| Altissimo Electronic Height Gages with Standard Components | | |
|--|-------|---|
| Cat. No. | EDP | Description |
| 2000-24 | 67008 | Height Gage |
| PT27937 | 67009 | Carbide Probe .1875" (4.8mm) Dia. (Standard) |
| PT27940 | 67010 | Probe Holder (Standard) |
| PT27944 | 67011 | Probe Calibration Block (Standard) |
| Accessories for Altissimo Electronic Height Gages | | |
| Part No. | EDP | Description |
| S2000AZ | 66997 | Accessory Set Includes: |
| PT27948 | 67012 | Probe Tip, 5-Way Adapter |
| PT23942 | 65255 | .040" (1mm) Carbide Contact Point |
| PT23914 | 64222 | .078" (2mm) Carbide Contact Point |
| PT23943 | 65256 | .120" (3mm) Carbide Contact Point |
| PT27952 | 67013 | Contact Wrench |
| PT27945 | 67014 | .400" (10.2mm) Cylindrical Probe |
| PT27950 | 67015 | Circular Carbide Scriber |
| PT27949 | 67016 | Depth Gage Attachment |
| PT27946 | 67017 | Holder for Dovetail Indicators |
| PT62011 | 67018 | Replacement Battery Pack, NiMH 6V |
| PT62015 | 67002 | Power Supply Charger for USA and Canadian Configuration |
| PT62130 | 67003 | Power Supply Charger for United Kingdom Configuration |
| PT62131 | 67004 | Power Supply Charger for European Configuration |
| 2000SCM | 69907 | Cable to 7612 or 7613 Multiplexer |
| 2000SCKB | 69908 | USB cable to PC (In focused window) |
| 2000SCU | 29728 | Cable to PC Running Data Collection SPC Software - USB |

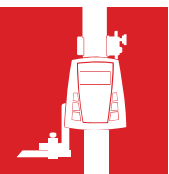

ELECTRONIC HEIGHT GAGES

3751 ELECTRONIC HEIGHT GAGE (WITHOUT OUTPUT)

0-6"/150MM

This height gage is light, portable and easy to use for vertical measurements within its range.

| 3751 Electronic Height Gage (0-6"/150mm Range) | | |
|--|-------|--|
| Cat. No. | EDP | Description |
| 3751AZ-6/150 | 12221 | Height Gage, in Case |
| Accessories and Cables for 3751 Electronic Height Gage | | |
| Part No. | EDP | Description |
| PT99492 | 65650 | One 3-Volt Batteries, CR2032 |
| PT08680A | 51383 | Depth Attachment for 6" (150mm) Height Gages |
| 947 | 56756 | Wood Case Only |



READABILITY FEATURES

- Easy-to-read LCD .32" high characters

ACCURACY AND LONG LIFE DESIGN FEATURES

- Hardened, stainless steel bar for long life
- Depth attachment PT08680A available for measuring depth of holes, slots, and recesses
- Fine adjustment thumb roll for precision measurements
- Rounded nose scriber cuts clean, sharp lines with smoothness and less pressure
- Lock to hold the slide in position
- Hardened, ground, and lapped base with finger grooves provides ease of movement
- Easy access to single long-life battery, 3-volt CR2032
- Vertical bar is back from the edge of the nose for better stability
- Scriber can reference zero from the bottom of the base to get the full 6" (150mm) usable range
- Linear Accuracy: $\pm .001"$ ($\pm 0.02\text{mm}$)
- Resolution: $.0005"$ (0.01mm)

ACTION FEATURES WITH THREE CONTROL BUTTONS

- Inch-millimeter conversion
- Zero at any position
- Manual ON/OFF plus a built in automatic OFF after 5 minutes of nonuse



NEW!

HEIGHT GAGES

ELECTRONIC HEIGHT GAGES

3754 ELECTRONIC HEIGHT GAGES

The 3754 Electronic Height Gage is a full featured, versatile and economic solution for most height measurement applications. All measuring information from these tools can be entered directly into Starrett Data Collection Systems for analysis, data collection and hard copy documentation. It is available in 0-12" and 0-24" ranges.

FEATURES

- Large (.380"/9.65mm), easy to read LCD display reads to .0005" or 0.01mm
- Large positive keypad
- Relative scale
- Fine adjust
- Furnished with two (2) 3-volt batteries (CR2032) and carbide tip scriber
- Improved battery cover



3754-12/300

On/Off Button
(auto off after 30 minutes of nonuse)

± Button
Toggles polarity or direction change

Hold Button
Retains current reading at any position



Primary: In/mm
Toggles Inch or metric readout

Secondary: LIMITS
min/max tolerance specifications at any position

Shift Set Button
Toggles between Primary and Secondary Functions

Primary: ZERO/ABS
Toggles Zero at current position or absolute

Secondary: PRESET Button
Install any reading at any position

3754 Electronic Height Gage

| Cat. No. | EDP | Range | Accuracy | Resolution |
|-------------|-------|---------------|--------------|------------|
| 3754-12/300 | 72625 | 0-12" (300mm) | 0.001" | .0005" |
| 3754-24/600 | 46003 | 0-24" (600mm) | .002" (>18") | .0005" |

Cables, Accessories, Cases for 3754 Electronic Height Gages

| Cat. No. | EDP | Description |
|----------|-------|--|
| PT61120 | 65446 | 3-volt battery, CR2032 (2), required |
| 928 | 55249 | Wood case only for 12" gage |
| 945 | 56684 | Wood case only for 24" gage |
| 733SCKB | 69888 | USB cable to PC (In focused window) |
| 733SCU | 69898 | USB cable to PC running SPC Data Collection software |
| 733SCM | 69893 | Cable to 7612 or 7613 Multiplexer |

Furnished without case unless otherwise ordered.

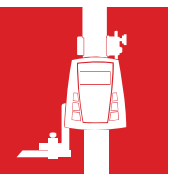

HOW TO READ A STARRETT 50-DIVISION VERNIER HEIGHT GAGE GRADUATED IN INCHES AND MILLIMETERS (DIRECT READING)

INCH READING

- Refer to the left side bar graduations and the inch vernier plate. Inches are numbered in sequence over the full range of the bar. Each bar graduation is .050". Every second graduation between the inch lines is numbered and equals .100".
- The vernier plate is divided into 50 parts, each representing .001". Every fifth line is numbered – 5, 10, 15 ... 45, 50 – for easy counting.
- To read the gage, first count how many inches and how many .050" lines lie between the zero line on the bar and the zero line on the vernier plate and add them.
- Then count the number of graduations on the vernier plate from its zero line to the line that coincides with a line on the bar. Multiply the number of vernier plate graduations you counted by .001" and add this figure to the number of inches and .050" lines you counted on the bar. This is your total reading.

EXAMPLE

- ★ In the photo, the vernier plate zero line is five inches (5.000") plus .750" beyond the zero line on the bar, or 5.750". The 25th graduation on the vernier plate coincides with a line on the bar (as indicated by stars). $25 \times .001$ (.025") is therefore added to the 5.750" bar reading, and the total reading is 5.775".

MILLIMETER READING

- Refer to the right side bar graduations and millimeter vernier plate. Each bar graduation is 1.00mm. Every tenth graduation is numbered in sequence – 10mm, 20mm, 30mm, etc. – over the full range of the bar. This provides for direct reading in millimeters.
- The vernier plate is divided into 50 parts, each representing 0.02mm. Every fifth line is numbered in sequence – 0.10mm, 0.20mm, 0.30mm ... 0.80mm, 0.90mm – providing for direct reading in hundredths of a millimeter.
- To read the gage, first count how many millimeters lie between the zero line on the bar and the zero line on the vernier plate.
- Then find the graduation on the vernier plate that coincides with a line on the bar and note its value in hundredths of a millimeter. Add the vernier plate reading in hundredths of a millimeter to the number of millimeters you counted on the bar. This is your total reading.

EXAMPLE

- ★ In the photo, the vernier plate zero line is 146 millimeters beyond the zero line on the bar, and the 0.68mm graduation on the vernier plate coincides with a line on the bar (as indicated by stars). 0.68 millimeters is therefore added to the 146 millimeter bar reading, and the total reading is 146.68 millimeters.

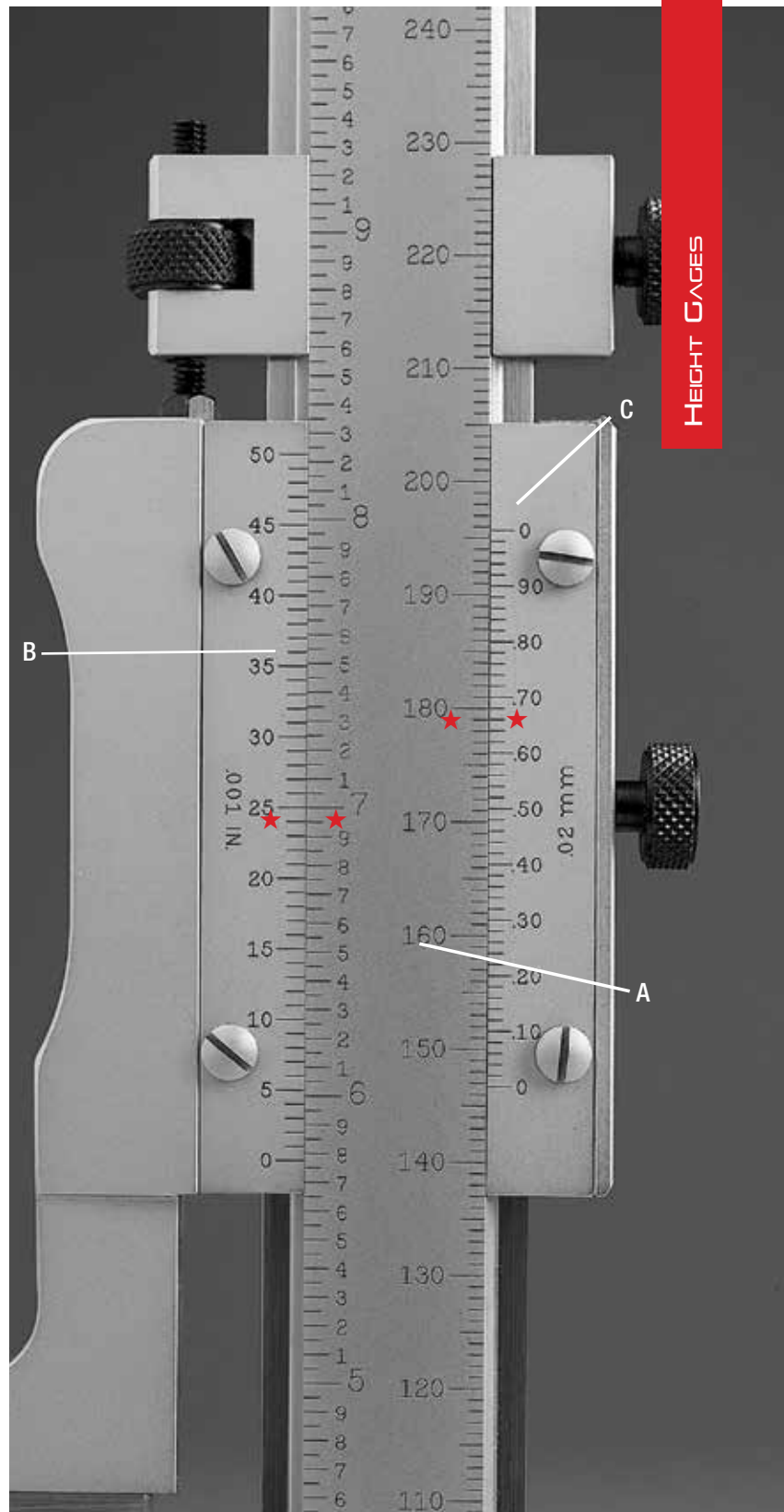

Open-face long Vernier with 50 widely spaced graduations for easy reading. Flush-fitting Vernier and master bar eliminates parallax.

A. Master Bar
B. Inch Vernier Plate
C. Millimeter Vernier Plate



VERNIER HEIGHT GAGES

254, 254M MASTER VERNIER HEIGHT GAGES

0-72"/0-900MM

254EM MASTER VERNIER HEIGHT GAGES

0-24"/0-600MM

This Master Vernier Height Gage is an accurate, rugged and reliable tool that gives precise and dependable measurements over long ranges. It has an easy-to-read vernier, is stronger, and is offered in greater ranges than other height gages.

READABILITY FEATURES

- Long, 50-division vernier scales permits half as many bar graduations as single vernier tools. These widely spaced graduations provide easy reading to .001" or 0.02mm
- Flush fitting of the vernier scales to the main scale eliminates parallax
- Vernier scales are adjustable
- Black lines and figures against Starrett satin chrome finish make reading easy
- Scriber and base are designed for direct reading from zero (bottom of base)

EASE-OF-HANDLING FEATURES

- Quick-adjust release on the slide allows for fast positioning
- Extremely fine adjustments by a knob on the base isolating the column and slide from external pressures
- Additional remote fine adjustment located on top of the bar for sizes 36" (900mm) and larger
- Special master bar design and the balanced design and weight of the base eliminates vibration
- Master bars on models up to 24" and 600mm are hardened and stabilized
- Base is hardened, ground, and lapped square with the bar and has finger grooves to provide ease of movement
- Vertical bar is positioned near the center of the base for balance and stability
- Versatile tool will scribe lines, mount dial indicators or electronic probes, and accept depth attachments
- Tool can also be used with our 359 Protractor for checking angles

| 254 Master Vernier Height Gages (.001" Graduation) | | | |
|---|-------|------------------------------------|-----------------------------|
| Cat. No. | EDP | Range | Approximate Base Dimensions |
| 254Z-12 | 51219 | 0-12" | 5-7/8" x 3-7/8" |
| 254Z-18 | 51220 | 0-18" | 7-1/2" x 4-1/2" |
| 254Z-24 | 51221 | 0-24" | |
| 254Z-36 | 51222 | 0-36" | 10" x 6-1/2" |
| 254Z-48 | 51223 | 0-48" | |
| 254Z-60 | 56183 | 0-60" | |
| 254Z-72 | 56184 | 0-72" | |
| 254M Master Vernier Height Gages (0.02mm Graduation) | | | |
| Cat. No. | EDP | Range | Approximate Base Dimensions |
| 254MZ-300 | 56214 | 0-300mm | 150mm x 95mm |
| 254MZ-450 | 56215 | 0-450mm | 190mm x 115mm |
| 254MZ-600 | 56216 | 0-600mm | |
| 254MZ-900 | 56217 | 0-900mm | 250mm x 165mm |
| 254EM Master Vernier Height Gages (.001"/0.02mm Graduation) | | | |
| Cat. No. | EDP | Range | Approximate Base Dimensions |
| 254EMZ-12 | 51224 | 0-12"/300mm | 5-7/8" x 3-7/8" |
| 254EMZ-18 | 51225 | 0-18"/450mm | 7-1/2" x 4-1/2" |
| 254EMZ-24 | 51226 | 0-24"/600mm | |
| Accessories for 254, 254M and 254EM Master Vernier Height Gages | | | |
| Part No. | EDP | Description | |
| PT22357 | 12295 | Auxiliary Straight Carbide Scriber | |
| PT28131 | 67007 | Auxiliary Circular Carbide Scriber | |
| PT05409A | 51227 | Depth Gage Attachment | |

Hardened bars on all sizes through 24" and 600mm
Furnished with Auxiliary Straight Carbide Scriber. Shown with optional Auxiliary Circular Carbide Scriber.



Quick-adjusting screw release allows rapid slide movement to desired area, then precisely position with the fine adjustment knob



Precise positioning with fine-adjustment knob on the base isolates column and slide from external pressures

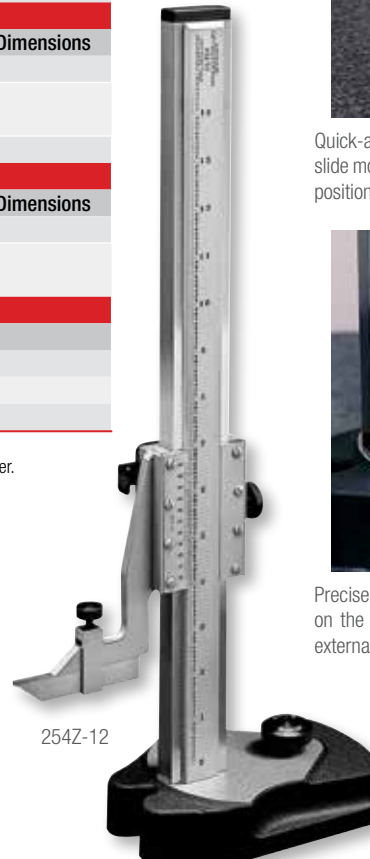

254Z-12

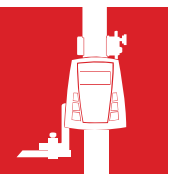

VERNIER HEIGHT GAGES

255, 255M VERNIER HEIGHT GAGES

0-18"/0-300MM

255EM VERNIER HEIGHT GAGES

0-18"/0-450MM

This tool is the "baby brother" of the 254 Master Vernier Height Gage. It is essentially the same tool, but a much lighter version for normal use where heavy duty applications are not practical. The 18" and 450mm models weigh 3-1/4 lb (1.5kg). No other height gage features this favorable combination of design, weight and accuracy.

READABILITY FEATURES

- Long, 50-division vernier scales that can be read to .001" or 0.02mm without a magnifying glass
- Flush-fitting of the vernier scales to the main scale eliminates parallax
- Easy-reading sharp black lines and figures against Starrett satin chrome finish background
- The scribe and the base are designed so that the gage will read directly from zero

EASE-OF-HANDLING FEATURES

- Slides easily for quick adjustment and has a screw type adjusting nut on the bar for precise positioning
- The design of the hardened and stabilized bar plus the balanced design and weight of the base eliminate vibration
- The base is hardened, ground, and lapped and is hand shaped for sure grip and easy movement
- The vertical bar is positioned near the center of the base for balance and stability
- Ability to scribe lines, measure with dial indicators or electronic probes and accept depth attachments
- The auxiliary scribe is a circular carbide scribe – cuts sharp, clean lines smoothly – rotatable for wear

| 255 Vernier Height Gages (.001" Graduation) | | | | | |
|--|-------|---|-------------------------------------|-----------------------------------|--------------|
| Cat. No. | EDP | Range | Bar Approximate (Width x Thickness) | Base Approximate (Length x Width) | Description |
| 255Z-12 | 51229 | 0-12" | 15/16" x 7/32" | 4-7/16" x 2-9/32" | In Case |
| 255-12 | 51230 | | | | Without Case |
| 255Z-18 | 51231 | 0-18" | 15/16" x 7/32" | 4-7/16" x 2-9/32" | In Case |
| 255-18 | 51232 | | | | Without Case |
| 255M Vernier Height Gages (0.02mm Graduation) | | | | | |
| Cat. No. | EDP | Range | Bar Approximate (Width x Thickness) | Base Approximate (Length x Width) | Description |
| 255MZ-300 | 56218 | 0-300mm | 24mm x 5.5mm | 113mm x 58mm | In Case |
| 255M-300 | 56219 | | | | Without Case |
| 255EM Vernier Height Gages (.001"/0.02mm Graduation) | | | | | |
| Cat. No. | EDP | Range | Bar Approximate (Width x Thickness) | Base Approximate (Length x Width) | Description |
| 255EMZ-18 | 65160 | 0-18"/450mm | 15/16" x 7/32" | 4-7/16" x 2-9/32" | In Case |
| 255EM-18 | 65161 | | (24mm x 5.5mm) | (113mm x 58mm) | Without Case |
| Accessories for 255, 255M and 255EM Vernier Height Gages | | | | | |
| Part No. | EDP | Description | | | |
| PT13791 | 71460 | Straight Scriber | | | |
| PT27710 | 67187 | Carbide Scriber (3/16" x 25/64" x 2-3/4") | | | |
| PT08962A | 51233 | Depth Gage Attachment | | | |

Furnished with Straight Scriber.

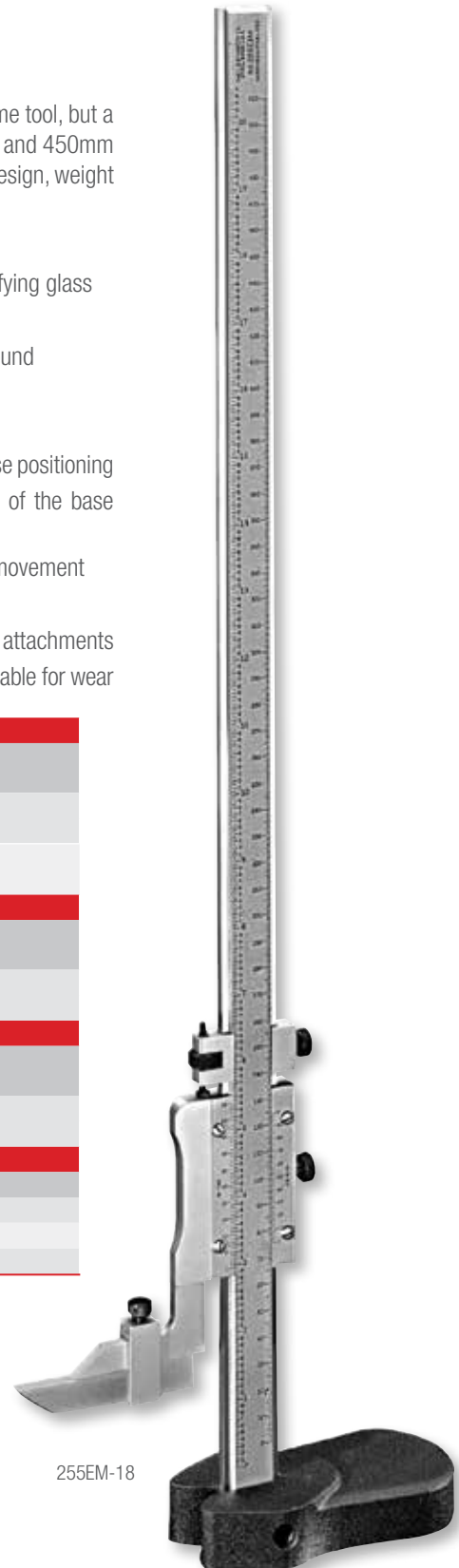

255EM-18



DIAL HEIGHT GAGES

3250 DIAL HEIGHT GAGES

0-6"/0-150MM

The compact 3250 Dial Height Gage is a very useful tool for machinists and inspectors. Applications include scribing lines for layout, height measurement (with or without dial test indicator), and depth measurement (with optional attachment). It is simple to use, reliable, accurate, and fits into most toolboxes.

| 3250 Height Gages | | | | |
|-------------------|-------|---------|------------|---------------------------|
| Cat. No. | EDP | Range | Dial Grads | Description |
| 3250Z-6 | 69865 | 0-6" | .001" | Dial Height Gage, English |
| 3250MZ-150 | 69861 | 0-150mm | 0.20mm | Dial Height Gage, Metric |
| PT08680A | 51383 | | | Depth Attachment |

FEATURES & SPECIFICATIONS

- Sharp, clear dial graduations of .001" or 2mm in one revolution
- Sharp, black graduations on the satin chrome finish bar every .100" or 1mm
- Fine adjustment thumb roll for precision measurements
- Vertical bar set back from the edge for better stability
- Hardened, ground, and lapped base with finger grooves for control and ease of movement
- Base clearance allows the gage to measure full gage range of 0 - 6" or 150mm
- Dial lock screw
- Lock to hold the slide in position
- The auxiliary scriber has a rounded nose for cutting clean, sharp lines with smoothness and less pressure
- Hardened, stainless steel bar, rack, gears, scriber, and scriber carrier
- Positive spring-loaded double pinion anti-backlash control
- Includes metal case

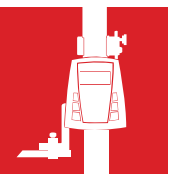

DIGI-CHEK™ HEIGHT GAGES

DHG DIGI-CHEK™ II HEIGHT MASTER

RANGES UP TO 85" AND 2150MM

These are the world's fastest and most precise height masters, ideal for those who need the highest degree of accuracy over an extremely long vertical range.

| DIGI-CHEK II Height Master (1-85" Range) | | |
|--|-------|----------|
| Cat. No. | EDP | Capacity |
| DHG 25. | 93265 | 1-25" |
| DHG 37. | 93266 | 1-37" |
| DHG 49. | 93267 | 1-49" |
| DHG 61. | 93268 | 1-61" |
| DHG 73.* | 93269 | 1-73" |
| DHG 85.* | 93270 | 1-85" |

| DIGI-CHEK II Height Master (25-2150mm Range) | | |
|--|-------|-----------|
| Cat. No. | EDP | Capacity |
| DHG 625. | 93271 | 25-625mm |
| DHG 1025. | 93272 | 25-1025mm |
| DHG 1225. | 93273 | 25-1225mm |
| DHG 1550. | 93274 | 25-1550mm |
| DHG 1800.* | 93640 | 25-1800mm |
| DHG 2150.* | 93275 | 25-2150mm |

* Setup charge extra depending on location.

| Optional Equipment for DIGI-CHEK II Height Master | | |
|---|-------|---|
| Cat. No. | EDP | Description |
| HG 525.60 (Inch) | 92579 | Reverse Reading Blocks |
| HG 501.3M (Millimeter) | 91486 | |
| HG 525.61 (Inch) | 92577 | 1" or 25mm base blocks for use with reverse reading blocks to set dial bore gages |
| HG 501.4M (Millimeter) | 91487 | |
| CS 9133. | 92320 | Finished wood case for reverse reading and base block |

| Specifications for DIGI-CHEK II Height Master | | |
|---|--|--|
| Description | Inch System | Metric System |
| Tolerance (Stack) | expressed in μin | expressed in μm |
| | Maximum: 2.5L + 10 (in inches) | .0025L + .25 (in mm) |
| | Minimum: -10 | - .25 |
| Parallelism: Gage Surfaces to Base and Each Other | 15 μin | 0.4 μm |
| Resolution | 10 μin or 20 μin | 0.5 μm or 1.0 μm |
| Repeatability of Readout | $\pm 20 \mu\text{in}$ | 0.5 μm or 1.0 μm |
| Digital Readout | 1/2" high figures | 12.5mm |
| Readout Pedestal Height | 38" | 970mm |
| Power Supply | Switchable: 115 V 60 Cycle or 220 V 50 Cycle | |
| Certificate of Calibration (Extra Cost) | expressed in μin | expressed in μm |
| Uncertainty of Calibration of Stack | 10 + 2.0L (in inches) | .25 + .002L (in mm) |
| Uncertainty of Calibration of Readout | $\pm 30 \mu\text{in}$ | $\pm 0.75 \mu\text{m}$ |

$\mu = .000001 \times \text{unit of measure}$

The accuracy of the surface that supports the gage must be taken into account when determining the accuracy of any measurements.

- Can be used in the laboratory or on the shop floor
- Lower inspection costs by saving time – within 10 seconds the tool can be set into position
- The gage block stack is free-standing, so it will adapt to temperature differences in a reasonable time period
- 1" or 25mm range of adjustment
- Reverse reading block allows readings from the underside of the master gage blocks
- The large, remote digital readout can be placed in the most convenient location and adjusted for best readability
- The housing is heavy and extremely stable with hardened and lapped three-point bearings
- Standard equipment: pedestal stand for readout unit, DIGI-CHEK II plastic dust cover and wood shipping/storage case



SIMPLE, TWO STEP OPERATION IN LESS THAN 10 SECONDS.

1. Set rapid positioner (A) to within .005" (0.15mm) (3 seconds).
2. Final setting (5 seconds).



NEW!

DIGI-CHEK™ HEIGHT GAGES

258, 258M DIGI-CHEK™ HEIGHT GAGES

.100"-24.100"/2-602MM

These gages combine the accuracy of Starrett-Webber Gage Blocks with a precision micrometer head and digital readout.

258 DIGI-CHEK Height Gages (.100"-24.100" Range)

| Cat. No. | EDP | Range | Graduation | | | |
|-----------|-------|---------------|------------|-----------------|-----------------|---------------|
| | | | Scales | Digital Readout | Micrometer Head | Gage Accuracy |
| DHG12-258 | 93005 | .100"-12.100" | Inches | .001" | .0001" | ±.0002" |
| DHG18-258 | 93006 | .100"-18.100" | | .001" | .0001" | ±.0002" |
| DHG24-258 | 93357 | .100"-24.100" | | .001" | .0001" | ±.0002" |

258M DIGI-CHEK Height Gages (2-602mm Range)

| Cat. No. | EDP | Range | Graduation | | | |
|------------|-------|-----------|-------------|-----------------|-----------------|---------------|
| | | | Scales | Digital Readout | Micrometer Head | Gage Accuracy |
| DHG300-258 | 93007 | 2mm-302mm | Millimeters | 0.01mm | 0.002mm | ±.005mm |
| DHG450-258 | 93008 | 2mm-452mm | | 0.01mm | 0.002mm | ±.005mm |
| DHG600-258 | 93358 | 2mm-602mm | | 0.01mm | 0.002mm | ±.005mm |

Finished wood case for 12" (300mm) and 18" (450mm) also available, at additional cost.

These finished wood cases are NOT suitable for shipping. Use suggested shipping materials.

Certificate of Calibration available at additional cost.

Questions and repair regarding Digi-Chek gages should be referred to the Starrett-Webber Division,

Tel.: 440-835-0001.

The accuracy of the surface that supports the gage must be taken into account when determining the accuracy of any measurements.

READABILITY FEATURES

- Satin chrome scales mounted beside the gage block column for quick reference to the nearest 1" or 25mm reading
- Digital readout reads in .001" or 0.01mm and has a range of 1" or 25mm
- Reads directly from the micrometer head to .0001" or 0.002mm. The micrometer head (our 469) has black figures on the satin chrome thimble. The graduations are staggered for easy counting.
- Both the micrometer head and digital readout are mounted on top of the gage, directly in line with the operator's vision

EASE-OF-HANDLING FEATURES

- The micrometer head has a speeder knob for rapid positioning
- Both over and under heights can be checked directly from the gage blocks in a single setting. Because reference surfaces are provided on the top and bottom of each block, adjacent blocks are in the exact same plane. This eliminates the need to add or subtract block thickness.
- Readings can also be taken from either left, center, or right of the gage block column
- Parts can be checked from .100" or 2mm in height
- The gage block column design permits wringing a 1" block between two blocks in the column. This is convenient for setting and checking other gages such as inside micrometers, end measuring rods, dial bore gages, etc.

ACCURACY AND LONG-LIFE FEATURES

- Gage is housed in a heavily flanged frame for stability and the base has three-point hardened, ground, and lapped bearing pads, making it virtually tip-proof. Gage blocks are assembled in a free-standing system that allows the blocks to conform to temperature variations independently of the frame, thereby reading the same as the workpiece.
- The highly accurate micrometer spindle is one piece, with hardened and stabilized measuring threads
- A 10" riser block is available for increased height capacity

HEIGHT GAGES

DGH12-258 with digital display



DGH12-258 with analog display

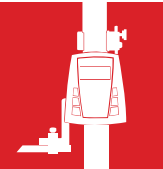

HEIGHT GAGE ACCESSORIES

DEPTH GAGE ATTACHMENTS FOR HEIGHT GAGES

These attachments replace standard scribes and measure the depths of holes and slots, recesses; inside of jigs, fixtures; and over high projections.

They have adjustable rods which are held in the desired position by a knurled binding nut. The ends have a slight radius for point contact on the work.

Right: PT08680A
Middle: PT08962A
Left: PT05409A



| Depth Gage Attachments for Height Gages | | | |
|---|-------|------------|---|
| Part No. | EDP | Rod Length | Fits Starrett Height Gage No./Size |
| PT08962A | 51233 | 6" (150mm) | 255 8", 12", 18", 300mm, 450mm |
| PT05409A | 51227 | 8" (200mm) | 254 12", 18", 24", 300mm, 450mm, 600mm and all Metric and English 259, 180 and 240, 3752 120 (300mm) and 240 (600mm), 755 240 (600mm) |
| PT08680A | 51383 | 6" (150mm) | 751 |

HEIGHT GAGES

258RRB, 258RRBM REVERSE READING BLOCKS FOR 258 DIGI-CHEK™ HEIGHT GAGE

Used on 258 DIGI-CHEK™ Height Gages for the precise calibration of working gages and for setting dial bore gages. The block fits in alternate inch positions, its tongue entering the odd numbers and its groove entering the even numbers of the gage block stack.

| 258RRB and 258RRBM Reverse Reading Blocks | | |
|---|-------|-----------------------------------|
| Cat. No. | EDP | Description |
| HG 258.RRB | 92433 | Fits 12", 18" and 24" Gages |
| HG 258.RRBM | 92434 | Fits 300mm, 450mm and 600mm Gages |

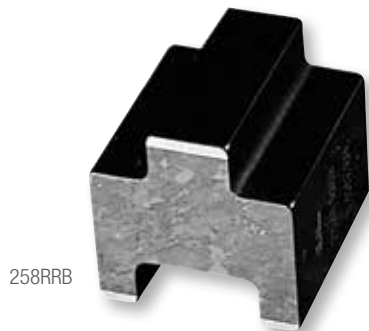

258RRB

258R, 258MR RISER BLOCKS FOR 258 DIGI-CHEK™ HEIGHT GAGE

Increases the range of Inch reading 258 DIGI-CHEK™ Height Gages by 10" and metric reading 258 DIGI-CHEKS™ by 250mm. Heavily flanged for rigidity and stability. Both top and base have three ground and lapped pads to match the pads on the DIGI-CHEK™ base. Retaining plate prevents the DIGI-CHEK™ from being pushed or sliding off the pads. Attractive black wrinkle finish. If desired, riser blocks can be stacked one on top of another.

| 258R Riser Blocks (10" Blocks) | | | |
|-----------------------------------|-------|-----------|------------|
| Cat. No. | EDP | Accuracy | For: |
| HG 258.R | 99865 | ±.000040" | 12" Gage |
| HG 258.RA | 99866 | | 18" Gage |
| 258MR Riser Blocks (250mm Blocks) | | | |
| Cat. No. | EDP | Accuracy | For: |
| HG 258.MR | 99867 | ±0.001mm | 300mm Gage |
| HG 258.MRA | 99868 | | 450mm Gage |



258R



HEIGHT GAGE ACCESSORIES

252 HEIGHT TRANSFER GAGES

0-48"/0-1200MM

The 252 Height Transfer Gage is ideal for use with test indicators or electronic amplifiers to accurately transfer height settings from gage blocks, height gages and other standards.

| 252 Height Transfer Gages | | | | | |
|---------------------------|-------|-------------------|-------------------------------|----------------------------------|--|
| Cat. No. | EDP | Range | Fine Adjustment (Approximate) | Base Size - L x W (Approximate) | Gage Rod Dimension |
| 252Z-14 | 55890 | 0-14" (350mm) | 3/8" (9.5mm) | 5-3/4" x 3-1/2" (145 x 90mm) | 9" L x .375" Dia. (225 x 9.5mm) with steps |
| 252Z-24 | 51216 | 0-24" (600mm) | | 7-1/2" x 4-1/2" (190 x 115mm) | |
| 252Z-48 | 51217 | 0-48" (1200mm) | | 9" x 6" (225 x 150mm) | |

Larger sizes available on special order.
Starrett 708, 709, 711, 650 Test Indicators; 25, 81, 196, 655, 656 Dial Indicators and supplementary attachments also available.
Gage furnished with 9" (225mm) Rod and PT06784-A Gage Holding Rod in wood case.

ACCURACY AND LONG-LIFE FEATURES

- Extreme rigidity provides the vibration-proof stability necessary to permit precise repeat readings with indicators of the highest amplification
- Extremely rigid, rectangular box-type hollow column mounted integrally on a heavy base
- Adjusting mechanism is located in the base so the column and indicator are isolated and not affected by external factors, such as heat or hand pressure

EASE-OF-OPERATION FEATURES

- Hand-fitting base design for sure-grip handling and easy movement
- Bottom of the base has three ground and lapped pads for stability and smooth movement on the surface plate
- Adjustable slide, incorporating a snug for holding test indicators or electronic gage heads, has rapid vertical manual adjustment
- Thumb screw allows slide to be locked
- Knob on base allows fine vertical adjustment of the slide unit relative to the fixed column. This permits the slide with its test indicator to be quickly and precisely adjusted to the desired setting.

TOOL AND GAGING HOLDERS

- A snug on the slide provides two holes (.375" [9.5mm] and .156" [4mm]) for holding gage rods or scribers. A 9" (225mm) rod furnished with the gage is especially useful for reaching confined areas or reaching heights greater than the range of the gage.
- The rod has a major diameter of .375" (9.5mm) and stepped diameters of 1/4" (3.2mm) and 7/32" (5.5mm) at one end and 5/16" (8mm) at the opposite end
- 708 and 709 Test Indicators can be mounted on this rod using PT22428 swivel clamp. 196 Universal Back-Plunger Indicators can be mounted using Starrett snugs, Part PT18718 or PT18724 (snugs not furnished).
- PT06784-A Gage Holding Rod is included to accommodate the 715-1 Gaging Head when the Transfer Gage is used with the 717 Electronic Gage. A wire retaining clip keeps electronic gage head cables from deflecting the gage-holding rod.
- 25, 81, 655 and 656 Dial Indicators also can be used on the height gage by means of a PT06784-A Gage Rod (furnished)
- Other useful attachments (extra) are surface gage spindles (57C or 57D, 12" [300mm]) and 18" [450mm] – which are extremely useful for scribing and layout

HEIGHT GAGES



Pictured with 717 Gage Amplifier and 715-12 lever probe.

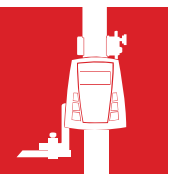

HEIGHT GAGE ACCESSORIES

STRAIGHT SCRIBERS FOR STARRETT HEIGHT GAGES*

All steel scribers are hardened to approximately HRC 62 and have a rounded tip which cuts sharp, clear lines smoothly, with less pressure, on any material.



| Straight Scribers for Starrett Height Gages | | | | |
|---|-------|---------------------|--|---|
| Part No. | EDP | Point | Size | Fits Starrett Height Gage No./Size |
| PT14343 | 71511 | | 1/4 x 1/2 x 3" (6.4 x 12.7 x 75mm) | 254 12", 18", 24", 300mm, 450mm, 600mm |
| PT13816 | 52367 | Hardened Tool Steel | 1/4 x 1/2 x 6" (6.4 x 12.7 x 150mm) | 254 Metric and English |
| PT13817 | 52368 | | 1/4 x 1/2 x 10" (6.4 x 12.7 x 250mm) | 259 18" and 24" |
| PT16566 | 72288 | Hardened Tool Steel | 5/8 x 3/8 x 3-5/8" | 254 36", 48", 60", 72", 900mm |
| PT13791 | 71460 | Hardened Tool Steel | 3/16 x 25/64 x 2-3/4" (4.8 x 10 x 69.9mm) | 255 8", 12", 18", 300mm, 450mm |
| PT22357 | 12295 | Carbide | 1/4 x 7/16 x 3" (6.4 x 11.1 x 75mm) | 3752 |

CIRCULAR CARBIDE SCRIBERS*

This circular scriber cuts a sharper, cleaner line with less pressure than any other scriber. It resists breakage and chipping but can be rotated for wear.

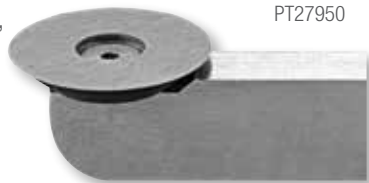

PT27950

| Circular Carbide Scribers | | | | |
|---------------------------|-------|------------------|--|--|
| Part No. | EDP | Point | Size | Fits Starrett Height Gage No./Size |
| PT27724 | 67185 | Circular Carbide | 1/4 x 1/2 x 3" (6.4 x 12.7 x 75mm) | 254 12", 18", 24", 300mm, 450mm, 600mm |
| PT27708 | 67186 | | 1/4 x 1/2 x 6" (6.4 x 12.7 x 150mm) | 254 Metric and English 259 18", 24" |
| PT27710 | 67187 | Circular Carbide | 3/16 x 25/64 x 2-3/4" (4.8 x 10 x 69.9mm) | 255 8", 12", 18", 300mm, 450mm |
| PT27950 | 67015 | Circular Carbide | 1/4" (6.4mm) Diameter Shank | 2000, 2001 Altissimo |
| PT28131 | 67007 | Circular Carbide | 1/4 x 7/16 x 3" (6.4 x 11.1 x 75mm) | 3752, 752 |

3259-AC DIGITAL HEIGHT GAGE SCRIBER CARRIER HOLDER

Scriber carrier for use with 3259 Height Gages to allow attachment of standard quarter inch by half inch tall accessories.



3259-AC

| 3259-AC Digital Height Gage Scriber Carrier Holder | | |
|--|-------|--|
| Cat. No. | EDP | Description |
| 3259-AC | 69859 | Digital height gage scriber carrier holder |

STEM-MOUNT INDICATOR ATTACHMENT FOR HEIGHT GAGES

This attachment replaces the standard scriber and provides a way to mount dial indicators or LVTD style probes having 3/8" diameter shafts onto your height gage. By using the lower stem of the indicator as an attachment point, the indicator can be used to guarantee the amount of down pressure on the part is the same as the original set zero position.



PT99441

Stem-Mount Indicator Attachment for Height Gages

| Part No. | EDP | Description |
|----------|-------|---------------------------------|
| PT99441 | 52991 | Stem-mount indicator attachment |

INDICATOR ATTACHMENT

DOVETAIL STYLE

Replaces standard scriber. Provides means to attach dovetail equipped test indicators or electronic probes to height gages. Allows indicator to be used to ensure the down pressure on the part is the same as the original set zero position.



PT99454

Dovetail Style Indicator Attachment

| Part No. | EDP | Description |
|----------|-------|--------------------------------------|
| PT99454 | 68713 | Indicator attachment, dovetail style |

*Starrett Originals

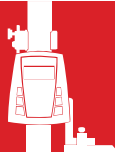



PRECISION MAKES THE DIFFERENCE

PURE PRECISION.

Introducing the HDV300 Video-based measurement system. The power of an optical comparator, meets the precision of digital video.



Starrett®

(978) 249-3551 • starrett.com

Follow us!





DEPTH GAGES

DEPTH GAGES

5004 ELECTRONIC DEPTH GAGES

0-24"/0-600MM

- Ideal for large part measurement up to 24" (600mm)
- Three movable bridge attachments provide additional large part measurement capacity

5004 Electronic Depth Gages

| Cat. No. | EDP | Range/Size | Description |
|---------------|-------|-----------------|-----------------------|
| 5004BZ-12/300 | 14583 | 0-12" (0-300mm) | Electronic depth gage |
| 5004BZ-16/400 | 14584 | 0-16" (0-400mm) | Electronic depth gage |
| 5004BZ-20/500 | 14585 | 0-20" (0-500mm) | Electronic depth gage |
| 5004BZ-24/600 | 14586 | 0-24" (0-600mm) | Electronic depth gage |
| 5004BZ-32/800 | 14587 | 0-32" (0-800mm) | Electronic depth gage |

Accessories for 5004 Depth Gages

| Part No. | EDP | Range/Size | Description |
|----------|-------|------------------------------|---|
| PT06133 | 12825 | 16" (400mm) | Movable bridge attachment for use with 5004 Depth Gages |
| PT06134 | 12826 | 20" (500mm) | Movable bridge attachment for use with 5004 Depth Gages |
| PT06135 | 12827 | 24" (600mm) | Movable bridge attachment for use with 5004 Depth Gages |
| PT06136 | 12828 | 1.024" (26mm) overall length | Offset attachment for use with 5004 Depth Gages |

Smart Cables for 5004 Depth Gages

| Cat. No. | EDP | Description |
|----------|-------|-------------------------------------|
| 798SCKB | 69889 | USB cable to PC (In focused window) |
| 798SCU | 73321 | SmartCable USB for 798, 5004B |
| 798SCM | 69894 | Connect to 7612, 7613 Gage Mux |

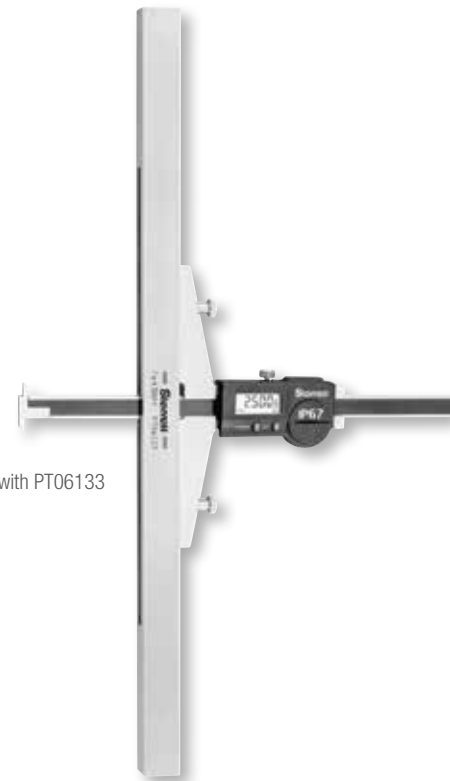
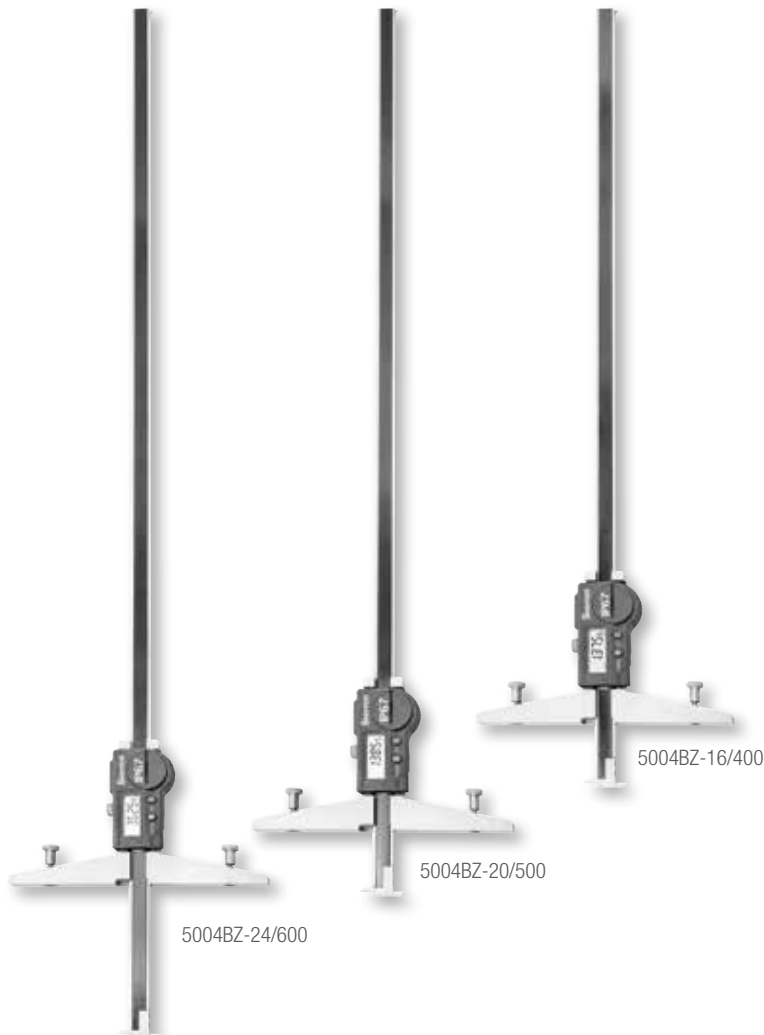

5004BZ with PT06133

FEATURES AND SPECIFICATIONS



- Hardened stainless steel construction
- Coolant resistant
- Mode and Set buttons control a wide range of functions: On/Off, Absolute/Relative display, Inch/Metric display, Preset and Hold
- RS232 data transmission port
- Furnished with one CR2032 lithium battery that will provide over a year of life with normal use
- Protective wooden case
- Resolution: 0.0005"/0.01mm
- Includes offset attachment PT06136
- IP67 protection

IP PROTECTION



An IP number is composed of two numbers, the first referring to protection against solid objects and the second against liquids.

First number 6: Totally protected against dust

Second number 7: Protection against submersion in water under standardized conditions of pressure for 30 minutes



DEPTH GAGES

3753A ELECTRONIC DEPTH GAGES

0-12"/0-300MM

The 3753 is light and easy to use for depth measurements within its range.

READABILITY FEATURES

- Clear, easily-read numbers, properly sized for the tool

DESIGN FEATURES FOR ACCURACY AND LONG LIFE

- Linear accuracy: $\pm .001"$ ($\pm 0.03\text{mm}$)
- Resolution: $.0005"$ (0.01mm)
- Exclusive Starrett-designed microprocessor chip
- Hardened stainless steel body and slide for long life
- Fine adjustment thumb roll for precision measurements
- Lock to hold the slide in position
- Hardened base is 3-15/16" (99mm) long, but optional base extensions of 7" and 12" (175 and 300mm) are available. Spacing between holes is 2-3/4" (70mm).
- A hook attachment is furnished with the gage, making it possible to take readings from the edge of a workpiece to edges of slots, grooves, shoulders, and other I.D. length dimensioning. The removable hook has the screw permanently attached to prevent loss.
- One-year minimum battery life with furnished 3-volt battery, CR2032

ACTION FEATURES WITH THREE CONTROL BUTTONS

- Inch/millimeter conversion
- Zero at any position
- Manual ON/OFF plus a built in automatic OFF after 15 minutes of nonuse



3753 with 180 extension



3753 shown with optional 3648-180 base extension attachment

| 3753A Electronic Depth Gages | | |
|--|-------|---------------------------------------|
| Cat. No. | EDP | Description |
| 3753A-6/150 | 12258 | 0-6"/150mm Range, Depth Gage in Case |
| 3753A-8/200 | 12259 | 0-8"/200mm Range, Depth Gage in Case |
| 3753A-12/300 | 12260 | 0-12"/300mm Range, Depth Gage in Case |
| Accessories for 3753A Electronic Depth Gages | | |
| Cat. No. | EDP | Description |
| 3648-180 | 12261 | 180mm Base Extension |
| 3648-260 | 12262 | 260mm Base Extension |
| 3648-320 | 12263 | 320mm Base Extension |
| PT99492 | 65650 | Two 3-Volt Batteries, CR2032 |



DEPTH GAGES

3753B ELECTRONIC DEPTH GAGES

0-12"/0-300MM

The 3753B Electronic Depth Gauge is a versatile, easy-to-use tool for measuring depth, slot width, small sections and other applications.

| 3753B Electronic Depth Gages | | |
|--|-------|--|
| Cat. No. | EDP | Description |
| 3753B-6/150 | 12690 | 0-6"/150mm Range, Depth Gauge in Case |
| 3753B-8/200 | 12692 | 0-8"/200mm Range, Depth Gauge in Case |
| 3753B-12/300 | 12694 | 0-12"/300mm Range, Depth Gauge in Case |
| Accessories for 3753B Electronic Depth Gages | | |
| Cat. No. | EDP | Description |
| 3648-180 | 12261 | 180mm Base Extension |
| 3648-260 | 12262 | 260mm Base Extension |
| 3648-320 | 12263 | 320mm Base Extension |
| PT63388 | 72517 | Computer Interface Cable to PC (USB) |
| PT99492 | 65650 | Two 3-Volt Batteries, CR2032 |
| 798SCKB | 69889 | USB cable to PC (In focused window) |
| 798SCU | 73321 | SmartCable USB for 798, 5004B |
| 798SCM | 69894 | To 7612 or 7613 |

FEATURES AND SPECIFICATIONS



- Hardened, stainless steel bar for long life
- Removable hook attachment for measurements from the edge of a work piece to the inside or outside edge of slots, grooves, etc.
- Lock to hold the slide in position
- Fine adjustment thumb roll for precision measurements
- Large, easy to read LCD, .310" character height
- IP67 level of protection against coolant, water, dirt and dust
- Induction type linear encoder system
- Patented non-contact RS-232 data output
- CR2032 3-volt battery (>1 year batter life under normal use)
- Inch/mm conversion
- Zero at any position
- Automatic off after 30 minutes of nonuse without loss of position upon reactivation
- Linear Accuracy: $\pm .001"$ (0.03mm)
- Resolution: $.0005"$ (0.010mm)

DEPTH GAGES



3753B-6/150

3753B-12/300

IP PROTECTION

An IP number is composed of two numbers, the first referring to protection against solid objects and the second against liquids.

First number 6: Totally protected against dust

Second number 7: Protection against submersion in water under standardized conditions of pressure for 30 minutes



DEPTH GAGES

450, 450M DIAL DEPTH GAGES

0-12"/0-300MM

These depth gages are ideal for the individual mechanic. They are light, reliable and accurate for measurements to .001" or 0.02mm and will fit into most toolboxes.

| 450 Dial Depth Gages (.001" Graduation) | | | |
|---|-------|--------------------------|-------------------------|
| Cat. No. | EDP | Range | Description |
| 450-6 | 56766 | 0-6" | 6" Gage without Case |
| 450-12 | 56768 | 0-12" | 12" Gage without Case |
| 450M Dial Depth Gages (0.02mm Graduation) | | | |
| Cat. No. | EDP | Range | Description |
| 450M-300 | 64276 | 0-300mm | 300mm Gage without Case |
| Accessories for 450 and 450M Dial Depth Gages | | | |
| Cat. No. | EDP | Description | |
| PT22287 | 65861 | 7"/175mm Base Extension | |
| PT22288 | 65862 | 12"/300mm Base Extension | |
| 450ZZ-6 | 56776 | 6" Case Only | |
| 450ZZ-12 | 56777 | 12" Case Only | |

READABILITY FEATURES

- Sharp, easy-to-read dial graduations of .001-.100" or 0.02-2mm in one revolution
- Sharp, black graduations on the satin chrome finished bar, every .100" or 1mm

EASE-OF-HANDLING AND VERSATILITY FEATURES

- Lock screw for dial bezel
- Lock screw for holding the measuring rod in position
- Optional base extensions of 7" and 12" (175 and 300mm) are available to increase the base span on both models
- Removable hook attachment permits readings from the edge of a workpiece to edges of slots, shoulders, etc.

ACCURACY AND LONG-LIFE FEATURES

- Hardened, stainless steel base, measuring bar, rack and gears
- Positive split gear anti-backlash control



Left: 6" model
Below: 12"/300mm base extension



DEPTH GAGES

448, 448ME VERNIER DEPTH GAGES

0-12"/0-300MM

These are easy-to-use, very accurate depth gages. They are designed for measuring the depths of holes, slots, and recesses and for inspecting jig, fixtures and die work. They are also ideal for measuring from a plane surface to toolmakers' buttons for locating center distances. Readings are in .001" and 0.02mm.

- Heads are hardened, ground and lapped
- Measuring blades are hardened and ground and have accurate and sharp machine divided graduations
- All English graduations read to .001", with the bar being graduated in .025" increments
- All metric graduations read to 0.02mm, with the bar being graduated in 0.5mm increments
- Screw type adjusting nut allows for fine measuring adjustment
- Slide lock nut to hold measurement position
- Vernier plates are adjustable

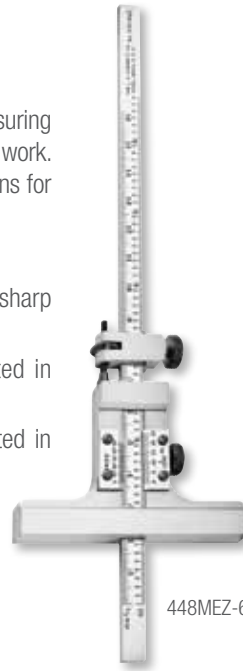

448MEZ-6

| Inch Reading/Graduation – .001" | | | | |
|--|-------|---------------|------------------------------|----------------------------|
| Cat. No. | EDP | Range | Blades Furnished | Base Length x Width |
| 448Z-6 | 52306 | 0-6" | One (6") | |
| 448Z-12 | 52308 | 0-12" | One (12") | 2-3/4 x 1/4" |
| 448Z-612 | 52310 | 0-12" | Two (6" and 12") | |
| Inch and Millimeter Reading/Graduation – .001" and 0.02mm – Both Edges | | | | |
| Cat. No. | EDP | Range | Blades Furnished | Base Length x Width |
| 448MEZ-6 | 52312 | 0-6" (150mm) | One (6"/150mm) | |
| 448MEZ-12 | 52314 | 0-12" (300mm) | One (12"/300mm) | 2-3/4 x 1/4" (70 x 6.35mm) |
| 448MEZ-612 | 52316 | 0-12" (300mm) | Two (6"/150mm and 12"/300mm) | |

237, 237M STEEL RULE DEPTH GAGES

0-6"/0-150MM

These very handy depth gages can be used to quickly obtain measurements in 64th of an inch or 1/2mm by simply adjusting the rule to the required depth.

- The gage consists of a nicely finished, hardened steel head and an accurate, machine divided, tempered steel rule. These rules are either our 610N (6") or our 635N (150mm) models.
- Gage can be smoothly adjusted to the required measurement and then locked into position by a knurled nut
- Base is cut out on one side, adjacent to the rule, permitting easier readings and more accurate measurements
- 6" hook rule (236HC, EDP 51077) also available, permitting easier readings from the edge of a workpiece to the edges of slots, shoulders, etc. Graduated in 32nds, 64ths.

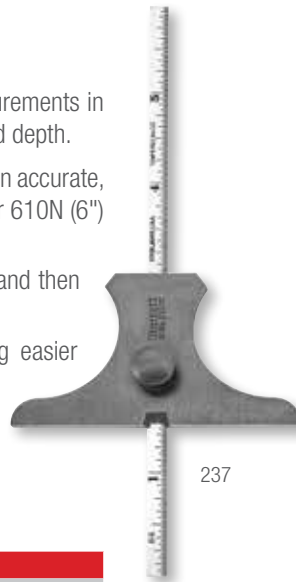

237

| 237 Steel Rule Depth Gages (0-6" Range) | | | |
|---|-------|--------------|---------------------|
| Cat. No. | EDP | Graduation | Head Length x Width |
| 237 | 51080 | 32nds, 64ths | 2-5/8 x 1/8" |
| 237M Steel Rule Depth Gages (0-150mm Range) | | | |
| Cat. No. | EDP | Graduation | Head Length x Width |
| 237M | 51081 | mm, 1/2mm | 66 x 3mm |

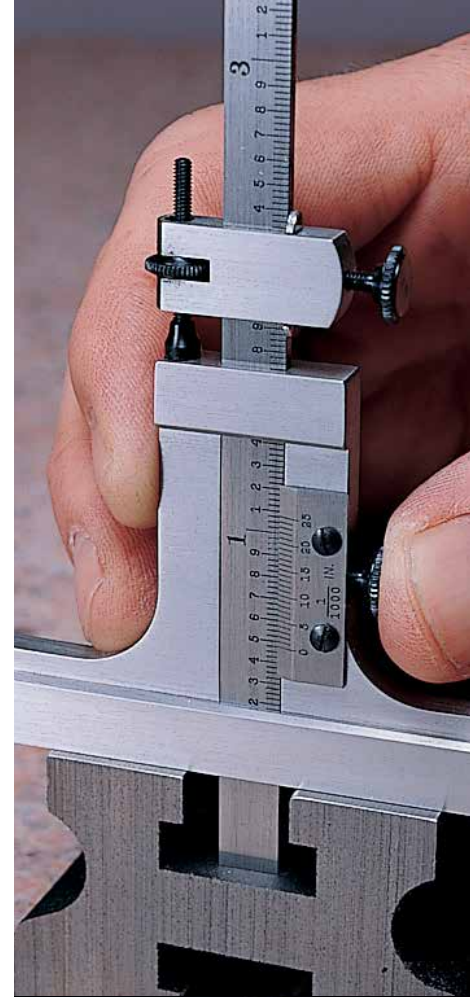

DEPTH GAGES

236, 236H COMBINATION STEEL RULE DEPTH AND ANGLE GAGES

0-6"

236

This depth gage has an added feature permitting its use as a protractor for measuring angles. It is a simple, handy tool that is a welcome addition to any machinist's toolbox.

- The head is graduated both left and right to 30, 45, and 60 degrees. The rule can be set to any of these angles by swinging the rule until the line on the turret coincides with the desired angle.
- Head is made of hardened steel, ground, and nicely polished – 2-5/8" (66mm) long and 1/8" (3mm) wide
- One side of the base is cut out to permit easier and more accurate readings
- The center of the head is recessed so that the tool will lay flat to permit more accurate measurements
- Tempered rule has been accurately machined divided, is smoothly fitted to the head, and can be locked in position by a knurled nut.

236H

These versatile gages can be used for calipering, as a depth gage by simply reversing the rule, as a protractor, and as a hook rule when removed from the tool.

Features are the same as the 236 except that a hook rule and an extra 6" (150mm) long rod are furnished with this gage. The rod has a 5/64" (2mm) diameter so it can measure the depth of small holes, slots, and recesses that the rule will not enter.

| 236 and 236H Combination Steel Rule Depth and Angle Gages (0-6" Range) | | | | |
|--|-------|--------------|---------------|--|
| Cat. No. | EDP | Graduation | Angle Degrees | Description |
| 236 | 51074 | | | 6" Combination Gage |
| 236HA | 51075 | 32nds, 64ths | 30, 45, 60 | 6" Combination Gage with Hook Rule |
| 236HB | 51076 | | | 6" Combination Gage with Hook Rule and Rod |
| 236HC | 51077 | 32nds, 64ths | None | 6" Hook Rule Only* |
| 236HD | 51078 | None | None | 6" Rod Only |

Also available on request with C610N-6 satin chrome rule.
 * Hook rule only for 236, 236H, 237, 493 and 493B.

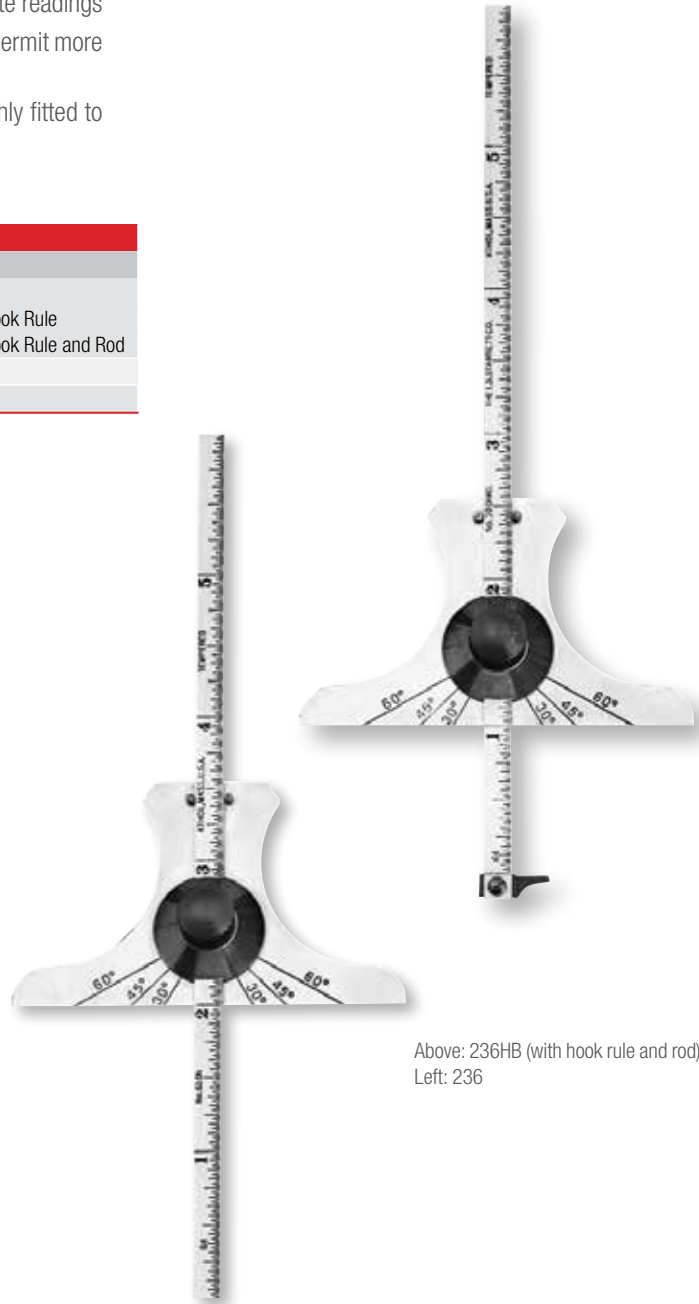

Above: 236HB (with hook rule and rod)
 Left: 236



DEPTH GAGES

DIAL DEPTH GAGES

These depth gages are direct reading tools, referencing from their hardened and ground bases. All bases are 2-1/2" (64mm) long. They are quicker and more convenient to use than any other type of depth gage within their ranges and accuracy. Electronic Indicators can be furnished by special order.

640, 640M DIAL DEPTH GAGES

0-1/2"/0-10MM

640 DIAL DEPTH GAGES

The contact is slightly up into the base at rest. In action, the inspector sets the contact at zero, which is usually at the bottom of the base. Then the top button is pushed down to contact the work and the measurement is taken.

640R DIAL DEPTH GAGES

These gages are the same as the 640 except they have reverse movement (no push button) and can easily be used with one hand. Simply set on zero and apply the contact to the work and read the measurement.



640

640 Dial Depth Gages

| 640 Dial Depth Gages | | | | |
|----------------------|-------|--------|------------|--------------|
| In Case | | | | |
| Cat. No. | EDP | Range | Graduation | Dial Reading |
| 640JZ | 52705 | 0-1/2" | .0005" | 0-50 |
| 640RJZ | 52709 | | | |
| 640MJZ | 55997 | 0-10mm | 0.01mm | 0-100 |
| 640MRJZ | 56001 | | | |

643 DIAL DEPTH GAGE

0-.125"

This gage has a knife-edge base and a needle point contact which has been hardened and ground. The knife-edge base has a cutout so the conical point can be precisely positioned for close work. Point is 1/2" (12.7mm) long with a 40° included angle.

In action, the inspector gently pushes against a surface plate or other calibrated surface. If needed, rotate the bezel dial's zero indication with the needle. Zero is then set and can be locked via the locking screw.



643

643 Dial Depth Gages

| In Case | | Without Case | | Range | Graduation | Dial Reading |
|----------|-------|--------------|-------|---------|------------|--------------|
| Cat. No. | EDP | Cat. No. | EDP | | | |
| 643JZ | 52714 | 643J | 52715 | 0-.125" | .0005" | 0-25-0 |

Electronic version available from Special Order Division.



DEPTH GAGES

644, 644M DIAL DEPTH GAGES

0-3"/0-75MM

These gages are for longer ranges, and are accurate and simple to use. Put the contact on the work to be measured and push the gage head down until the base stops at the reference point and take your reading.

Furnished with three rounded-end contact points to cover the range. Flat end contact points are also available on special order.

The zero setting can be checked with the shortest contact in place by pushing down on a flat surface.

| 644 Dial Depth Gages | | | | | | |
|----------------------|-------|--------------|-------|--------|------------|--------------|
| In Case | | Without Case | | Range | Graduation | Dial Reading |
| Cat. No. | EDP | Cat. No. | EDP | | | |
| 644JZ | 52718 | 644J | 52719 | 0-3" | .001" | 0-100 |
| 644MJZ | 56027 | 644MJ | 56028 | 0-75mm | 0.01mm | 0-100 |



644J



648-4

648 DEPTH GAGE BASES

Depth gage base with 25SC38 Stem Collet to fit 3/8" (9.5mm) stem dia. (as per AGD). Split bushings for adapting stem diameter are available but not included.

| 648 Depth Gage Bases | | |
|----------------------|-------|------------|
| Cat. No. | EDP | Base Size |
| 648-4 | 65850 | 4" (100mm) |
| 648-6 | 65851 | 6" (150mm) |
| 648-8 | 65852 | 8" (200mm) |

648 Depth Gage Bases will also accommodate the 644 Dial Depth Gage.



DEPTH GAGES

642, 642M TOP READING DIAL DEPTH GAGES

0-8.6"/0-215MM

This dial depth gage uses the back-plunger indicator to provide an upward-facing dial for easier readout. The operator selects the extension and contact point required, zeros the tool on a master and then reads any deviation of the work directly on the dial.

- Indicator does not have to be repositioned to get the full range available
- Choice of 2-1/2" (60mm) or 4" (100mm) base
- Two contacts and five extensions extend the range to 8.6" or 215mm
- Charts are supplied showing combinations of contacts and extensions required to achieve certain lengths



Above: 642AZ side view
Below: top view



| 642 Top Reading Dial Depth Gages* | | | | | |
|-----------------------------------|-------|---------|------------|----------------------|---------------------|
| Cat. No. | EDP | Range | Graduation | Dial Indicator Range | Approx. Base Length |
| 642Z | 65103 | 0-8.6" | .001" | .200" | 2-1/2" |
| 642AZ | 65104 | 0-8.6" | .001" | .200" | 4" |
| 642MZ | 65105 | 0-215mm | 0.01mm | 5mm | 60mm |
| 642MAZ | 65106 | 0-215mm | 0.01mm | 5mm | 100mm |

*With maximum extension added and contact options

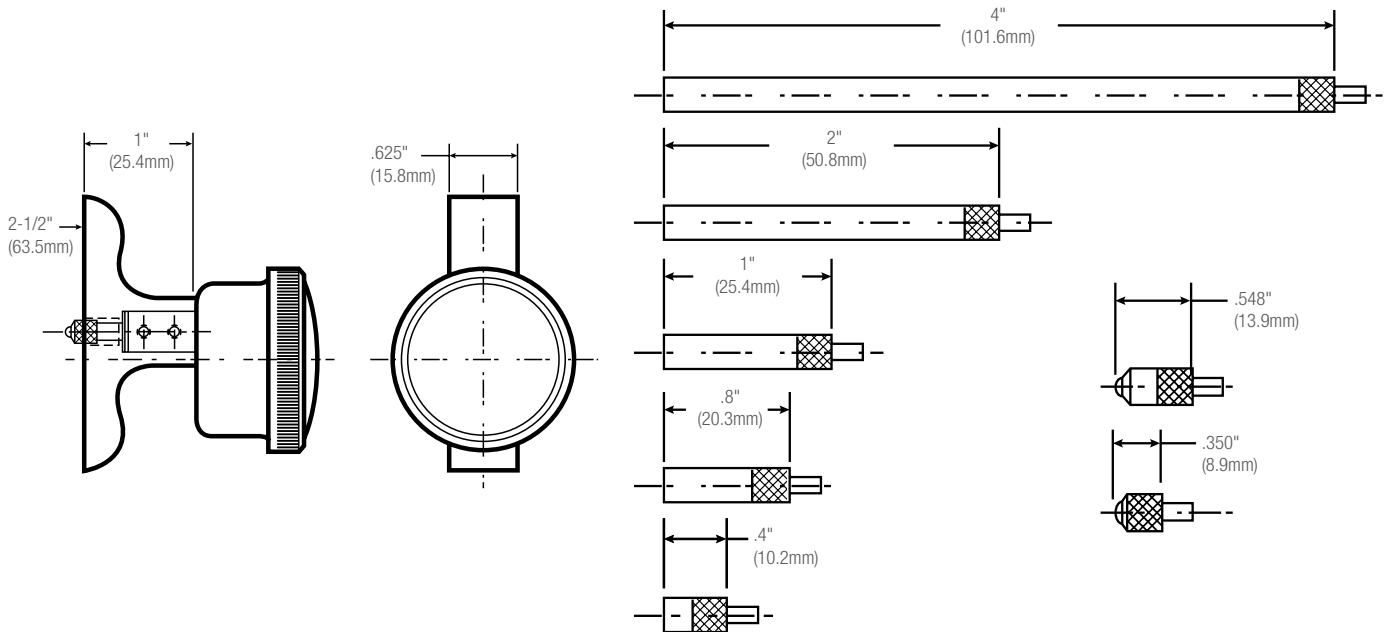

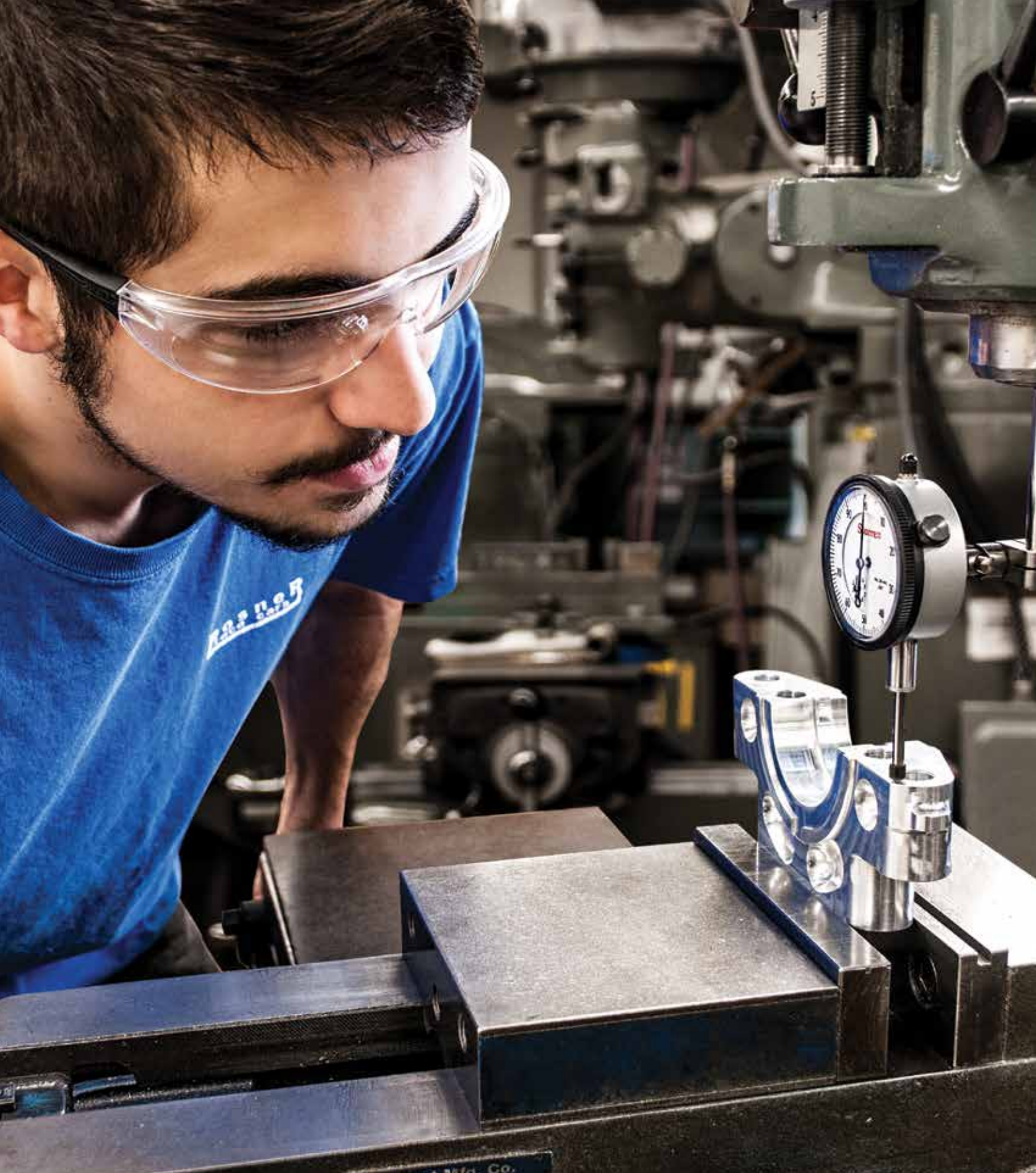

DIAL AND ELECTRONIC
INDICATORS AND GAGES

TEST INDICATOR SNUGS AND SPLIT BUSHINGS USAGE GUIDE

DOVE TAIL STYLE SNUGS:

PT22428: 3/32-1/4" (2.4-6.3mm) inch hole on one side and standard female dove connection on the other. For use with 708, 709 and 811 Test Indicators. Allows connection to 657AA, 657A, 657T Magnetic Base and PT017762 Holding Rod for 252 Height Stand and PT11770A Tool Post Holder or 711-49 Height Gage Attachment.

ROUND CONNECTION SNUGS:

657S: 1/4" hole on both ends

PT18718: 3/32-1/4" hole on one end 5/16" on the other

PT18724: 3/32-1/4" hole on one end 3/8" on the other

657H: 3/8" inch hole on both ends

665D: 3/8" inch hole on one end .465" (11.8mm) on the other. Includes 665L (.375" bushing)

PT16846 (not shown): 3/4" inch hole on both ends

UNIVERSAL STYLE SNUGS:

58S: 3/32-1/4" hole allows connection to 1/4", 5/16", 3/8" (6.3, 8, 9.5mm)

UNIVERSAL DRUM STYLE SNUGS:

57S: 5/16" and 3/8" (8, 9.5mm) on one end and 9/64", 5/32", 3/16", 1/4" (3.5, 4, 4.8, 6.3mm) on the opposite

NOTE: 3/8-1/4" bushings can be used with some of the snugs above to change 3/8"-1/4" where required (see PT00764)

SPLIT BUSHINGS:

657R: outside .312" (7.9mm), inside .250" (6.3mm), length 1.000" (25.4mm)

PT00764: .375" (9.5mm) outside, inside .250" (6.3mm), length 1/2" (12.7mm)

80SB: outside .375" (9.5mm), inside .219" (5.5mm), length 1/2" (12.7mm). Used to increase the stem diameter on Starrett 80 miniature indicators to standard .375" diameter.

25MSB: outside .375" (9.5mm), inside .316" (8mm), length 1/2" (12.7mm), converts metric stemmed indicator to standard 3/8" diameter

665L: outside .465 (11.8mm), inside .375" (9.5mm), length 1-1/4" (31.5mm)

25SB: outside .500" (12.7mm), inside .375" (9.5mm), length 1/2" (12.7mm)



BEST PRACTICES FOR TEST INDICATORS AND HOLDERS

Test indicators are primarily used for testing or checking parts and for machine setups. They are a tool that is indispensable for working as a machinist or toolmaker. They are available in two types – plunger style and the lever style. Both are versatile, but the lever style can be more adaptable to smaller, confined working areas.

Unlike other indicators, the lever style's contact moves in an arc rather than in a straight line. This can cause a slight inaccuracy called "cosine error" if the angle of the lever to the workpiece is too steep. If, for example, a lever was set off an additional 20°, there could be an error of .0006" in a .010" range (0.012 mm in a 0.2mm range).

It is good practice, therefore, to keep your contact at or near 90° to the direction of movement.

Test indicators should always be "loaded" 1/10 to 1/4 of a turn before measuring.

Test indicators are comparative instruments that check and compare to known standards or that are used to zero-out setups.

We have a broad selection of holders shown in this section that allow you to use these indicators to the fullest. We've never seen a job that one of these holders combined with one of our test indicators could not handle.

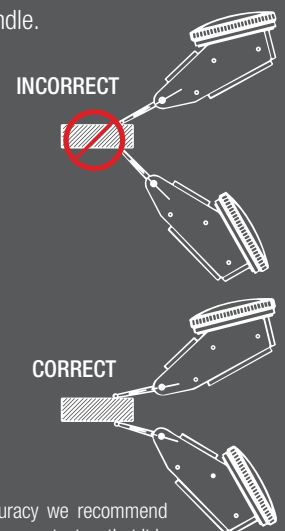

For extreme accuracy we recommend positioning the lever contact so that it is approximately 15° (708/709) or 0° (all other lever styles) from being horizontal with the workpiece



TEST INDICATORS

708, 708M, 709, 709M DIAL TEST INDICATORS WITH DOVETAIL MOUNTS

.020", .060"/0.2MM, 0.8MM

These precision test indicators offer an easy to read angled head and the flexibility of three dovetail mounts. Features include:

- Large 1-3/8" (35mm) dial diameter with angled head
- Precision gear-driven design with smooth, jeweled movement
- Replaceable contact point reverses automatically, always maintaining clockwise hand rotation
- Satin chrome finish for durability
- Contacts are frictionally adjustable and replaceable
- Revolution count hand on 708B and 709B models
- Meet or exceed ISO accuracy specification



708BZ

R708AZ

| Individual Carbide Contact Points† | | | | | | |
|------------------------------------|-------|---------|------|---------------|----|---------------------------------------|
| Part No. | EDP | Length | | Ball Diameter | | Fits Models |
| | | in | mm | in | mm | |
| PT23942 | 65255 | | | .040 | 1 | |
| PT23914† | 64222 | 13/16 | 20 | .078 | 2 | .0001", .0005", 0.01mm Reading Models |
| PT23943 | 65256 | | | .120 | 3 | |
| PT27024† | 66239 | 1-23/64 | 34.4 | .078 | 2 | .0001", .0005", 0.01mm Reading Models |
| PT25577† | 67294 | 1-5/64 | 28.4 | .078 | 2 | .0001", .0005", 0.01mm Reading Models |
| PT23953† | 65868 | 5/8 | 16 | .078 | 2 | 0.002mm Reading Models Only |

† PT23914, PT27024, PT25577 and PT23953 furnished as standard.

‡ Length of carbide contacts must be the same as contacts normally furnished.



709BCZ

| 708, 709 Dial Test Indicators with Dovetail Mounts | | | | | | | | | | |
|--|-------|---------------|-------|--------|--------|--------------|-----------------------|-------------|------------|---------------------|
| Cat. No. | EDP | With SLC** | | Grad. | Range | Dial Reading | Carbide Contact Point | | | Description |
| | | Cat. No. | EDP | | | | Length | Ball Dia. | Dial Color | |
| 708AZ | 64212 | 708AZ W/SLC | 66866 | .0001" | .010" | 0-5-0 | 13/16" (20mm) | .078" (2mm) | White | Without attachments |
| R708AZ | 64603 | R708AZ W/SLC | 66867 | | | | | | Red | |
| B708AZ | 64607 | B708AZ W/SLC | 66868 | | | | | | Black | |
| 708ACZ | 64217 | 708ACZ W/SLC | 66869 | | | | | | White | |
| R708ACZ | 64604 | R708ACZ W/SLC | 66870 | Red | .0001" | .020" | 13/16" (20mm) | .078" (2mm) | Black | With attachments* |
| B708ACZ | 64608 | B708ACZ W/SLC | 66871 | White | | | | | | |
| 708BZ | 64213 | 708BZ W/SLC | 66874 | Red | | | | | | |
| 708BCZ | 64218 | 708BCZ W/SLC | 66875 | Black | | | | | | |
| 709AZ | 64214 | | | .0005" | .030" | 0-15-0 | 13/16" (20mm) | .078" (2mm) | White | Without attachments |
| R709AZ | 64605 | | | | | | | | Red | |
| B709AZ | 64609 | | | | | | | | Black | |
| 709ACZ | 64219 | | | | | | | | White | |
| R709ACZ | 64606 | | | Red | .0005" | .050" | 1-23/64" (34.4mm) | .078" (2mm) | Black | With attachments* |
| B709ACZ | 64610 | | | White | | | | | | |
| 709ALZ | 65857 | | | Red | | | | | | |
| 709ALCZ | 65858 | | | Black | | | | | | |
| 709BZ | 64215 | | | .0005" | .060" | 0-15-0 | 13/16" (20mm) | .078" (2mm) | White | Without attachments |
| 709BCZ | 64220 | | | | | | | | White | |

| 708M, 709M Dial Test Indicators with Dovetail Mounts | | | | | | | | | | |
|--|-------|---------------|-------|---------|-------|--------------|-----------------------|-------------|------------|---------------------|
| Cat. No. | EDP | With SLC** | | Grad | Range | Dial Reading | Carbide Contact Point | | | Description |
| | | Cat. No. | EDP | | | | Length | Ball Dia. | Dial Color | |
| 708MAZ | 65864 | 708MAZ W/SLC | 66872 | 0.002mm | 0.2mm | 0-100-0 | 5/8" (16mm) | .078" (2mm) | Yellow | Without attachments |
| 708MACZ | 65865 | 708MACZ W/SLC | 66873 | | | | | | Yellow | |
| 709MAZ | 64216 | | | 0.01mm | 0.8mm | 0-40-0 | 13/16" (20mm) | .078" (2mm) | Yellow | Without attachments |
| 709MACZ | 64221 | | | | | | | | Yellow | |
| 709MALZ | 67092 | | | 0.01mm | 1.0mm | 0-50-0 | 1-5/64" (28.4mm) | .078" (2mm) | Yellow | Without attachments |
| 709MALCZ | 67093 | | | | | | | | Yellow | |

*Attachments include dovetail body clamp (PT22429/EDP 72441), tool post holder (PT11770A/EDP 71361), swivel post snug with dovetail indicator clamp (PT22428/EDP 72440), and snug and rod unit (Inch: PT22430/EDP 72442 or Millimeter: PT27171/EDP 66457).

** Includes redemption card for Standard Letter of Certification



TEST INDICATORS

811, 811M DIAL TEST INDICATORS WITH SWIVEL HEAD

.060", 0.8MM

These are some of the most versatile and unique indicators available, the swivel head feature allows positioning to suit your line of sight from horizontal to vertical and at any angle up to 90°.

- Two positioning mounts work with dovetail test indicator accessories
- Contacts are frictionally adjustable and replaceable
- Contact point reverses, always maintaining clockwise hand rotation
- Contacts also available individually in steel, carbide, and different sizes
- Smooth, jeweled movement
- Large, 1-3/8" (35mm) dial diameter for increased readability
- Inch reading indicators are available with white, red, or black dials – metric indicators with yellow dials

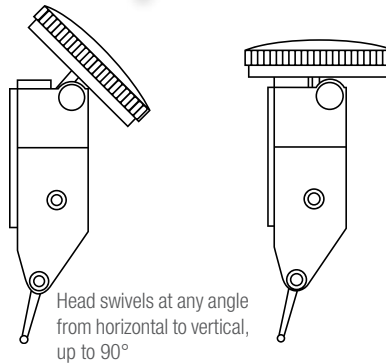

Individual Contact Points for 811 and 811M Dial Test Indicators with Swivel Head

| Part No. | EDP | Length | | Ball Diameter | | Material | Fits 811 Models |
|----------|-------|--------|----|---------------|-----|----------|--------------------------------|
| | | in | mm | in | mm | | |
| PT23062 | 72451 | 5/8 | 16 | .032 | 0.8 | Steel | .0005" and 0.01mm reading only |
| PT23062X | 72452 | | | | | Carbide | |
| PT22315 | 72443 | 5/8 | 16 | .078 | 2 | Steel | .0005" and 0.01mm reading only |
| PT22315X | 72453 | | | | | Carbide | |
| PT23064 | 72454 | 1-5/16 | 33 | .032 | 0.8 | Steel | .001" reading only |
| PT23064X | 72455 | | | | | Carbide | |
| PT23011 | 72444 | 1-5/16 | 33 | .078 | 2 | Steel | .001" reading only |
| PT23011X | 72456 | | | | | Carbide | |

811, Dial Test Indicators with Swivel Head

| Cat. No. | EDP | Grad. | Range | Dial Reading | Steel Contact Points | | Dial Color | Description |
|----------|-------|--------|-------|--------------|----------------------|---------------|------------|-----------------------------|
| | | | | | Length | Ball Diameter | | |
| 811-5PZ | 57080 | .0005" | .030" | 0-15-0 | 5/8" (16mm) | .078" (2mm) | White | In case without attachments |
| B811-5PZ | 63262 | | | | | | Black | |
| R811-5PZ | 63266 | | | | | | Red | |
| 811-5CZ | 57079 | .0005" | .030" | 0-15-0 | 5/8" (16mm) | .078" (2mm) | White | In case with attachments* |
| B811-5CZ | 63261 | | | | | | Black | |
| R811-5CZ | 63265 | | | | | | Red | |
| 811-1PZ | 57082 | .001" | .060" | 0-30-0 | 1-5/16" (33mm) | .078" (2mm) | White | In case without attachments |
| B811-1PZ | 63264 | | | | | | Black | |
| R811-1PZ | 63268 | | | | | | Red | |
| 811-1CZ | 57081 | .001" | .060" | 0-30-0 | 1-5/16" (33mm) | .078" (2mm) | White | In case with attachments* |
| B811-1CZ | 63263 | | | | | | Black | |
| R811-1CZ | 63267 | | | | | | Red | |

811M Dial Test Indicators with swivel head

| Cat. No. | EDP | Grad. | Range | Dial Reading | Steel Contact Points | | Dial Color | Description |
|----------|-------|--------|-------|--------------|----------------------|---------------|------------|-----------------------------|
| | | | | | Length | Ball Diameter | | |
| 811-MPZ | 57084 | 0.01mm | 0.8mm | 0-40-0 | 5/8" (16mm) | .078" (2mm) | Yellow | In case without attachments |
| 811-MCZ | 57083 | | | | | | | In case with attachments* |

*Attachments include dovetail body clamp (PT22429/EDP 72441), tool post holder (PT11770A/EDP 71361), swivel post snug with dovetail indicator clamp (PT22428/EDP 72440), and snug and rod unit (Inch: PT22430/EDP 72442 or Millimeter: PT27171/EDP 66457).



TEST INDICATORS

ATTACHMENTS FOR 708, 709, AND 811 TEST INDICATORS

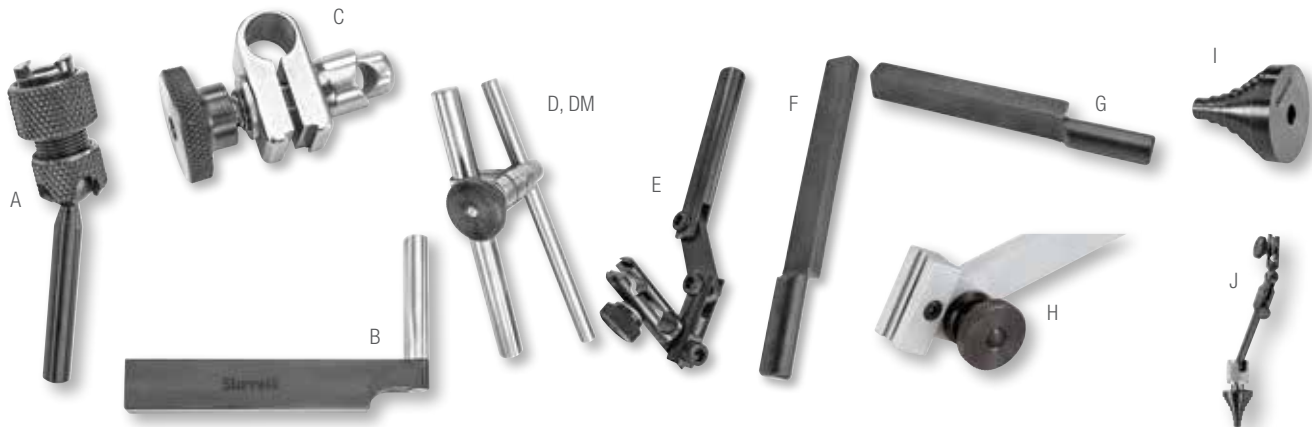

A. DOVETAIL BODY CLAMP

PT22429. 3/16" (4.8mm) diameter rod. For use in chucks, collets or surface gage snugs.

B. TOOL POST HOLDER

PT11770A. 1/4" x 1 5/16" (6.3 x 33mm) post and 1/4" x 1/2" (6.3 x 12.7mm) shank. For use in tool posts or in height gages.

C. SWIVEL POST SNUG WITH DOVETAIL INDICATOR CLAMP

PT22428. Will fit over spindles and posts 3/32-1/4" (2.4-6.3mm). Can be used directly on our 252 Height Transfer Gage and our 657 Magnetic Base Holders. It is frequently used on the 1/4" (6.3mm) rod of the Snug and Rod Unit PT22430.

D. SNUG AND ROD UNIT

PT22430. This unit consists of a snug (PT18724) with two 4" (100mm) long rods, one a 1/4" (6.3mm) diameter, the other a 3/8" (9.5mm) diameter. It is generally used with an indicator attached to PT22428 Swivel Post Snug which slides onto the 1/4" (6.3mm) diameter rod.

The 3/8" (9.5mm) rod will fit into the 252 and 657H Gage Holders. It also has the ability to be held in chucks and adjusted to a wide range of heights and diameters.

DM. METRIC SNUG AND ROD UNIT

PT27171. This unit consists of a snug with two 100mm (4") long rods, one having a 6mm (.236") diameter, the other an 8mm (.315") diameter.

E. INDICATOR AXIAL SUPPORT

PT26007. This triple-hinged indicator holder is designed to mount dovetail indicators (such as our 708, 709, and 811 Indicators). By using a rod through the 3/16" (4.7mm) mounting hole, it will also accommodate test indicators such as our 711 Indicator. Overall length is approximately 5-1/4" (133mm), shank size is 3/8" (9.5mm).

F HEIGHT GAGE ATTACHMENT

711-49. 1/8" x 5/16" (3 x 8mm) shank. This is used for 250, 750, 751 Height Gages, and 995 Planer and Shaper Gage.

G. HEIGHT GAGE ATTACHMENT

711-35. 3/16" x 3/8" (4.8 x 9.5mm) shank. This is used for 255 Height Gage.

H. INDICATOR ATTACHMENT

PT99454 dovetail clamping style. Replaces standard scriber. Provides means to attach dovetail equipped test indicators or electronic probes to height gages. Allows indicator to be used to ensure that the down pressure on the part is the same as the original set zero position.

I. AND J. COLLET ADAPTERS

PT28315 (I.)– To be used with a 3/16" (4.7mm) diameter attachment for indicators such as PT22429 dovetail body clamp and PT07104F long and short arm attachments. PT28316 (J.)– Swivel Post Collet Adapter, for use on any dovetail test indicator.

| Attachments for 708, 709, and 811 Test Indicators | | | |
|---|----------|-------|--------------------------------------|
| Photo Key | Part No. | EDP | Description |
| A* | PT22429 | 72441 | Dovetail Body Clamp |
| B* | PT11770A | 71361 | Tool Post Holder |
| C* | PT22428 | 72440 | Swivel Post Snug with Clamp |
| D* | PT22430 | 72442 | Snug and Rod Unit |
| DM | PT27171 | 66457 | Metric Snug and Rod Unit |
| E | PT26007 | 65101 | Indicator Axial Support |
| F | 711-49 | 52941 | Height Gage Attachment |
| G | 711-35 | 52942 | |
| H | PT99454 | 68713 | Indicator Attachment, dovetail style |
| I | PT28315 | 68847 | Collet Adapter |
| J | PT28316 | 68848 | |

* Furnished with all sets having "C" in the catalog number



TEST INDICATORS

711, 711M LAST WORD® DIAL TEST INDICATORS

.030", 0.7MM

The venerable Last Word Dial Test Indicator is among the most versatile available. Their small size and variety of attachments will handle all jobs with ease and accuracy. A very useful feature is the shaded dial – when used with a mirror, such as in a jig bore application, the operator will always know what the correct reading is.

Individual Contact Points (Fit All 711 Models)

| Part No. | EDP | Length | | Ball Diameter | | Material |
|----------|-------|--------|----|---------------|-----|----------|
| | | in | mm | in | mm | |
| PT07137 | 70945 | 5/32 | 4 | .035 | 0.9 | Steel |
| PT07136 | 70944 | | | .062 | 1.6 | |
| PT07087 | 70912 | | | .120 | 3 | |
| PT07137X | 52964 | 5/32 | 4 | .035 | 0.9 | Carbide |
| PT07136X | 52965 | | | .062 | 1.6 | |
| PT07087X | 52966 | | | .120 | 3 | |

OTHER FEATURES INCLUDE:

- Ideal for precise measurements in all machining, layout, and inspection work
- Smooth, jeweled lever action
- Positive reversing switch
- Hard chrome-plated ratchet contact point
- Swiveling tubular body
- Easy reading dials, half yellow for clarity
- Variety of attachments available to suit the application.
- Indicators having "C" in the catalog number are furnished with 3 interchangeable steel contact points. All other indicators are furnished with one interchangeable steel contact point, PT07087. Carbide points available as listed.

711 Last Word® Dial Test Indicators

| Cat. No. | EDP | Grad. | Range | Dial Reading | Steel Contact Points | | Description |
|----------|-------|--------|-------|--------------|----------------------|---|---|
| | | | | | Length | Ball Diameter | |
| 711FSAZ | 52925 | .001" | .030" | 0-15-0 | 5/32" (4mm) | One: .120" (3mm) | Indicator with universal shank complete with long and short arm, body clamp |
| 711FSBZ | 52927 | | | | | | Indicator with gooseneck shank |
| 711FSZ | 52929 | | | | | | Indicator with body clamp only |
| 711GPSZ | 52944 | | | | | | Indicator with universal friction holder with shank |
| 711GCSZ | 52943 | .001" | .030" | 0-15-0 | 5/32" (4mm) | Three: .035" (0.9mm) .062" (1.6mm) .120" (3mm) | Indicator complete with all attachments* |
| 711HSAZ | 52951 | .0005" | .030" | 0-15-0 | 5/32" (4mm) | One: .120" (3mm) | Indicator with universal shank complete with long and short arm, body clamp |
| 711HSZ | 52953 | | | | | | Indicator with body clamp only |
| 711LPSZ | 52958 | | | | | | Indicator with universal friction holder with shank |
| 711LCSZ | 52957 | .0005" | .030" | 0-15-0 | 5/32" (4mm) | Three: .035" (0.9mm) .062" (1.6mm) .120" (3mm) | Indicator complete with all attachments* |

711M Last Word® Dial Test Indicators

| Cat. No. | EDP | Grad. | Range | Dial Reading | Steel Contact Points | | Description |
|----------|-------|--------|-------|--------------|----------------------|---|---|
| | | | | | Length | Ball Diameter | |
| 711MFAZ | 52926 | 0.01mm | 0.7mm | 0-35-0 | 5/32" (4mm) | One: .120" (3mm) | Indicator with universal shank complete with long and short arm, body clamp |
| 711MFSZ | 52930 | | | | | | Indicator with body clamp only |
| 711MGPSZ | 52946 | | | | | | Indicator with universal friction holder with shank |
| 711MGCSZ | 52945 | 0.01mm | 0.7mm | 0-35-0 | 5/32" (4mm) | Three: .035" (0.9mm) .062" (1.6mm) .120" (3mm) | Indicator complete with all attachments* |

*Attachments include 3 contact points – body clamp – universal friction holder with shank – universal shank complete with long and short arm – double-jointed attachment – height gage attachment – surface gage attachment – coupling with 3/16" (4.8mm) hole.

711LPSZ Indicator with Universal Friction Holder and Shank



711FS-GS



TEST INDICATORS

ATTACHMENTS FOR 711 LAST WORD® DIAL TEST INDICATORS



A. BODY CLAMP

PT07101F Permits the indicator to be held by its body and clamped to any diameter rod from 1/8-1/4" (3-6mm). It also attaches the universal shank to the indicator with the addition of PT07104F Long and Short Arm.

B. UNIVERSAL FRICTION HOLDER

with shank 711EA – This inserts in place of the end plug at the top of the indicator body. The shank has a 3/16" (4.8mm) diameter which will fit into chucks and also into the snugs of our 57 and 257 Surface Gages.

C. UNIVERSAL SHANK

PT07103A. This shank includes PT07104F (the long and short arm) to go into the body clamp. With its shank size of 1/4" x 1/2" (6.4 x 12.7mm), this can be used in a lathe tool post or for 254 Height Gage.

D. GOOSENECK SHANK

PT07107A. 1/4" x 1/2" (6.4 x 12.7mm) shank can be used on tool posts and on the same height gages as the PT07103A Universal Shank. It is attached by unscrewing the body clamp and replacing it with the gooseneck shank.

E. DOUBLE-JOINTED ATTACHMENT

PT13301. This attachment has a 3/8" (9.5mm) diameter at one end and a 1/4" (6.3mm) diameter at the other end and will fit into chucks and collets, (such as in a jig borer) and hold the indicator by the body clamp, giving it greater depth and diameter range.

F. LONG AND SHORT ARM

PT07104F. This is used with the universal shank to attach it to the body clamp. It has a 3/16" (4.8mm) diameter and arms with 13/16" and 1-3/16" (20mm and 30mm) lengths.

G. COUPLING WITH 3/16" (4.8MM) HOLE

PT05116. Coupling slips over the long and short arm PT07104F and the shank of 711EA Universal Friction Holder to permit offset.

H. HEIGHT GAGE ATTACHMENT

PT24706 – This inserts in place of the end plug at the top of the indicator body. The 3/16" x 11/32" (4.8 x 8.7mm) shank fits 255 12", 18" and 24" Height Gages.

I. HEIGHT GAGE ATTACHMENT

711-49. 1/8" x 5/16" (3 x 8mm) shank. This is used for 250, 750, 751 Height Gages and 995 Planer and Shaper Gage.

J. HEIGHT GAGE ATTACHMENT

711-35. 3/16" x 3/8" (4.8 x 9.5mm) shank. This is used for 255 Height Gage.

K. INDICATOR AXIAL SUPPORT

PT26007. This triple-hinged indicator holder is designed to mount dovetail indicators (such as our 708, 709, and 811 indicators). By using a rod through the 3/16" (4.7mm) mounting hole, it will also accommodate test indicators such as our 711 indicators. Overall length is approximately 5 1/4" (133mm), shank size is 3/8" (9.5mm).

L. SURFACE GAGE ATTACHMENT

PT05119. Fits in place of the ball shank of the 711EA Attachment. Allows 711G and L Indicators to be used on holders with smaller clamp hole.

M. TOOL POST HOLDER

PT11770A. 1/4" x 1 5/16" (6.3 x 33mm) post and 1/4" x 1/2" (6.3 x 12.7mm) shank. For use in tool posts or in height gages

N. RUBBER DUST GUARD

PT09764. Protects the indicators' working parts by sealing out dust, powder, and other foreign matter under adverse gaging conditions.

O. COLLET ADAPTER

PT28315. To be used with a 3/16" (4.7mm) diameter attachment for indicators such as PT22429 dovetail body clamp and PT07104F long and short arm attachments.

Attachments for 711 Last Word Dial Test Indicators

| Photo Key | Part No. | EDP | Description |
|-----------|----------|-------|--|
| A* | PT07101F | 70924 | Body Clamp |
| B* | 711EA | 52924 | Universal Friction Holder with Shank |
| C* | PT07103A | 52939 | Universal Shank Complete with Long and Short Arm |
| D | PT07107A | 52937 | Gooseneck Shank |
| E* | PT13301 | 71441 | Double-Jointed Attachment |
| F* | PT07104F | 70929 | Long and Short Arm |
| G* | PT05116 | 70556 | Coupling with 3/16" (4.8mm) Hole |
| H* | PT24706 | 65064 | Height Gage Attachment |
| I | 711-49 | 52941 | Height Gage Attachment |
| J | 711-35 | 52942 | Height Gage Attachment |
| K | PT26007 | 65101 | Indicator Axial Support |
| L* | PT05119 | 70557 | Surface Gage Attachment |
| M | PT11770A | 71361 | Tool Post Holder |
| N | PT09764 | 71290 | Rubber Dust Guard |
| O | PT28315 | 68847 | Collet Adapter |

*Furnished with all sets having "C" in the catalog number



TEST INDICATORS

3808, 3809, 3908 AND 3909 DIAL TEST INDICATORS

These dial test indicators are offered with choices of dial size, range and include accessories.

All 3808 and 3809 models have 1-1/4" (32mm) dial faces while 3908 and 3909 models offer a larger 1-9/16" (40mm) dial face.

3808, 3809, 3908 and 3909 Inch Reading Indicators

| Cat. No. | EDP | Grad. | Range | Dial Reading | Dial Diameter | Description |
|----------|-------|--------|-------|--------------|---------------|---------------------------------------|
| 3808A | 12331 | .0001" | .008" | 0-4-0 | 1-1/4" | Indicator, two dovetail clamps, case* |
| 3808AC | 12303 | | | | | Indicator with accessories, case** |
| 3908A | 12488 | .0001" | .008" | 0-4-0 | 1-9/16" | Indicator, two dovetail clamps, case* |
| 3908AC | 12636 | | | | | Indicator with accessories, case** |
| 3809A | 12333 | .0005" | .030" | 0-15-0 | 1-1/4" | Indicator, two dovetail clamps, case* |
| 3809AC | 12305 | | | | | Indicator with accessories, case** |
| 3909A | 12527 | .0005" | .030" | 0-15-0 | 1-9/16" | Indicator, two dovetail clamps, case* |
| 3909AC | 12669 | | | | | Indicator with accessories, case** |

*Indicator, .078" contact point, 3/8" and 5/32" dovetail clamps and case

**Indicator, .078" contact point, 3/8" and 5/32" dovetail clamps, .156" swivel post holder, tool post holder, contact wrench and case

3808, 3809, 3908 and 3909 Metric Reading Indicators

| Cat. No. | EDP | Grad. | Range | Dial Reading | Dial Diameter | Description |
|----------|-------|---------|-------|--------------|---------------|---------------------------------------|
| 3808MA | 12332 | 0.002mm | 0.2mm | 0-100-0 | 32mm | Indicator, two dovetail clamps, case* |
| 3808MAC | 12304 | | | | | Indicator with accessories, case** |
| 3908MA | 12520 | 0.002mm | 0.2mm | 0-100-0 | 40mm | Indicator, two dovetail clamps, case* |
| 3908MAC | 12656 | | | | | Indicator with accessories, case** |
| 3809MA | 12334 | 0.01mm | 0.8mm | 0-40-0 | 32mm | Indicator, two dovetail clamps, case* |
| 3809MAC | 12307 | | | | | Indicator with accessories, case** |
| 3909MA | 12563 | 0.01mm | 0.8mm | 0-40-0 | 40mm | Indicator, two dovetail clamps, case* |
| 3909MAC | 12673 | | | | | Indicator with accessories, case** |

*Indicator, 2mm contact point, 9.5mm and 4mm dovetail clamps and case

**Indicator, 2mm and 4mm contact points, 9.5mm and 4mm dovetail clamps, 4mm swivel post holder, tool post holder, contact wrench and case

Each inch reading and metric reading 3808, 3809, 3908 and 3909 is offered with a choice of two Graduation/Range/Reading configurations. Features include:

- Precision gear-driven design with smooth, jeweled movement
- Frictionally adjustable contact point reverses automatically, always maintaining clockwise hand rotation
- Meets or exceeds ANSI/ASME accuracy specifications
- High contrast, easy-to-read dials with white background for inch and yellow for metric



3909A



3909MA



BACK PLUNGER INDICATORS

650, 651 BACK-PLUNGER DIAL INDICATORS

.200"

These workhorse back plunger indicators feature AGD (American Gage Design) stem holding fixtures and the great variety of AGD contact points. These very versatile indicators have the following features:

- 650 Indicators have a 3" (75mm) deep hole attachment that connects directly with the main spindle for positive action. Attachment is convenient to use when checking internal dimensions of a workpiece. When not needed, the attachment can be easily removed and the hole capped.
- 651 Indicators are identical to the 650 indicators except they cannot accept the deep hole attachment
- Both models have large 1-11/16" (43mm) diameter bezels with easy-to-read dial numbers and graduations
- Smooth and accurate operation due to their sturdy, basic design
- Hardened, stainless steel AGD stem .375" (9.5mm) diameter
- Shank dimension 1/4" (6.3mm) diameter, 3-3/16" (80mm) long
- With their .375" (9.5mm) AGD stem diameter, the 650 and 651 can be used with our 670 Hole Attachment and our 671 Universal Attachment
- Adjustable dials to set zero at any point opposite the hand
- Inch reading dials have white faces and millimeter reading dials are yellow
- Three different styles of contact points are furnished with each indicator



INDICATORS AND GAGES

| 650, 651 Back Plunger Dial Indicators | | | | | | | |
|---------------------------------------|-------|------------------------------|-------|-------|-------|--------------|--|
| With Deep Hole Attachment | | Without Deep Hole Attachment | | Grad. | Range | Dial Reading | Description |
| Cat. No. | EDP | Cat. No. | EDP | | | | |
| 650A1Z | 64475 | 651A1Z | 64483 | .001" | .200" | 0-100 | Indicator with 3 contact points, 3 attachments*, in case |
| 650B1 | 64477 | 651B1 | 64485 | | | | Indicator with 3 contact points only |
| 650A5Z | 64474 | 651A5Z | 64484 | .001" | .200" | 0-50-0 | Indicator with 3 contact points, 3 attachments*, in case |
| 650B5 | 64476 | 651B5 | 64486 | | | | Indicator with 3 contact points only |

| 650, 651 Back Plunger Dial Indicators | | | | | | | |
|---------------------------------------|-------|------------------------------|-------|-------|--------|------------------|--|
| With Deep Hole Attachment | | Without Deep Hole Attachment | | Grad. | Range | Dial Reading | Description |
| Cat. No. | EDP | Cat. No. | EDP | | | | |
| 650MA1Z | 65261 | 651MA1Z | 65263 | 5mm | 0.01mm | 0-100 | Indicator with 3 contact points, 3 attachments*, in case |
| 650MB1 | 65262 | 651MB1 | 65264 | | | Yellow Dial Face | Indicator with 3 contact points only |

* Attachments include clamp, tool post holder and snug (PT18718).

| Individual Contact Points Only | | |
|--------------------------------|-----------|-------|
| Photo | Part No. | EDP |
| | PT01761 | 75263 |
| | PT06632-5 | 70793 |
| | PT06632-6 | 70794 |

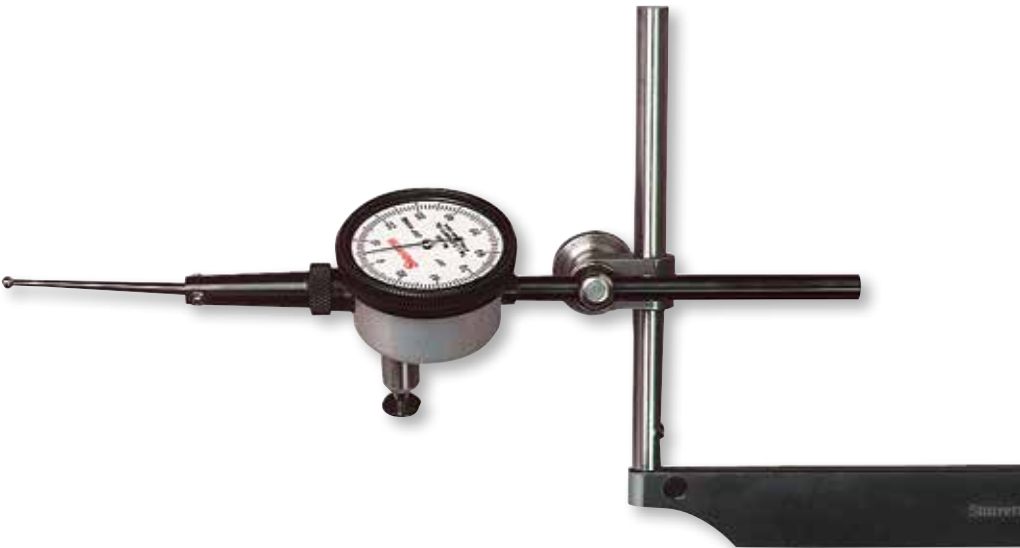

BACK PLUNGER INDICATORS

196, 196M UNIVERSAL BACK PLUNGER DIAL INDICATORS

.200", 5MM

Our 196 Indicator is one of the most versatile indicators available ... and it is the "granddaddy" of them all. Over the years this tool has been improved by methods and materials, but the basic design is unchanged. The design has withstood the test of time and beaten all challengers because it is:

- Accurate and reliable
- Simple to operate
- Rugged, with few moving parts
- Smooth in operation



196R, 196MR



PT05471



PT05472

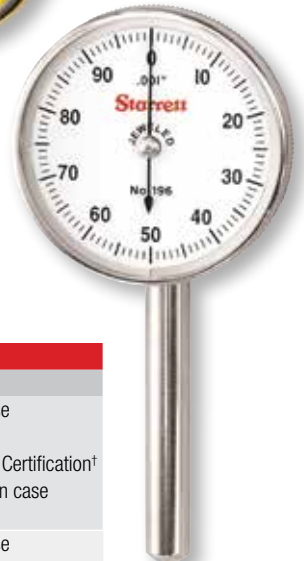

PT05473

Left: 196MB1
Below: 196B1

Contact Points and Adapters Only for 196 and 196M Universal Back Plunger Dial Indicators

| Catalog/Part No. | EDP | Description |
|------------------|-------|------------------------------|
| 196R | 50711 | Adapter** |
| 196MR | 67457 | Adapter (metric threads) |
| PT05471 | 70617 | Hardened steel contact point |
| PT05472 | 70618 | |
| PT05473 | 70619 | |

** For Contact Points with #4-48 Thread, see AGD Contact Listings.

196 Universal Back Plunger Dial Indicators (1/4" Shank Diameter)

| Cat. No. | EDP | Grad. | Range | Dial Reading | Description |
|-------------|-------|-------|-------|--------------|---|
| 196A1Z | 50697 | | | | Indicator with 3 contact points, adapter, 4 attachments* in case |
| 196B1 | 50699 | | | | Indicator with 3 contact points and adapter only |
| 196B1 W/SLC | 66865 | .001" | .200" | 0-100 | Indicator with 3 contact points, adapter, and Standard Letter of Certification† |
| 196A6Z | 50701 | | | | Antimagnetic Indicator with 3 contact points, 4 attachments* in case |
| 196B6 | 50702 | | | | Antimagnetic Indicator with 3 contact points only |
| 196A5Z | 50714 | .001" | .200" | 0-50-0 | Indicator with 3 contact points, adapter, 4 attachments* in case |
| 196B5 | 50717 | | | | Indicator with 3 contact points and adapter only |

196M Universal Back Plunger Dial Indicators (6.3mm Shank Diameter)

| Cat. No. | EDP | Grad. | Range | Dial Reading | Description |
|----------|-------|--------|-------|-------------------------|---|
| 196MA1Z | 65251 | | | | Indicator with 3 contact points, adapter, 4 attachments* in case |
| 196MB1 | 65252 | 0.02mm | 5mm | 0-100 Yellow Dial Face | Indicator with 3 contact points and adapter only |
| 196MA5Z | 65253 | 0.02mm | 5mm | 0-50-0 Yellow Dial Face | Indicator with 3 contact points, adapter 196R, 4 attachments* in case |
| 196MB5 | 65254 | | | | Indicator with 3 contact points and adapter only |

* Attachments include clamp, tool post holder, snug and hole attachment.

† Includes redemption card for Standard Letter of Certification (SLC).

While there is a need for indicators with finer graduations, such as our 708 Indicators, this indicator with graduations to .001" and 0.02mm will handle by far the majority of jobs. Shank diameter is 1/4" (6.3mm). Antimagnetic models are also available: (inch reading) 196A6Z and 196B6.

For full use, the operator first chooses the proper contact from the three hardened contact points that come with each model. Then the contact should be brought against the work with enough pressure to give the hand one full turn. Set the hand at zero by rotating the dial with the knurled bezel. This provides one full rotation of the hand both to the right and left of zero, showing a rise or drop in the work and the amount of that variation.



BACK PLUNGER INDICATORS

ATTACHMENTS FOR 650, 651, 196 AND 196M BACK PLUNGER DIAL INDICATORS AND UNIVERSAL DIAL INDICATORS

A. CLAMP

PT99437 With a 1-5/16" (33mm) flat or round capacity – 5/16" (8mm) post (PT03709-1/2) used with PT18718 Snug.

B. TOOL POST HOLDER

PT99438 3/8" x 3/4" x 6" (9.5 x 19 x 150mm) with upright spindle (PT03820-0) 5/16" dia. x 4-1/2" length (8 x 114mm). Use with PT18718 Snug.

C. SNUG COMPLETE

PT18718. Post hole has a 5/16" diameter† and 3/32-1/4" holding capacity. Can be used on our 252 Height Transfer Gage, 57 and 257A and B Surface Gages, on 657A Magnetic Base and Swivel Post Assembly.

D. SNUG COMPLETE

PT18724. Post hole has a 3/8" diameter (9.5mm) and 3/32-1/4" (2.4-6.3mm) holding capacity. Can be used with our 57 and 257C and D Surface Gages or 657AA Magnetic Base with upright post.

E. UNIVERSAL SNUG

57S With spindle hole diameters 5/16", 3/8" (8, 9.5mm) and gripping hole diameters 9/64", 5/32", 3/16", 1/4" (3.5, 4, 4.8, 6.3mm).

F. UNIVERSAL SNUG

58S. With spindle hole diameters 1/4", 5/16", 3/8" (6.3, 8, 9.5mm). Gripping hole diameters range from 3/32-1/4" used on holders with smaller clamp hole.

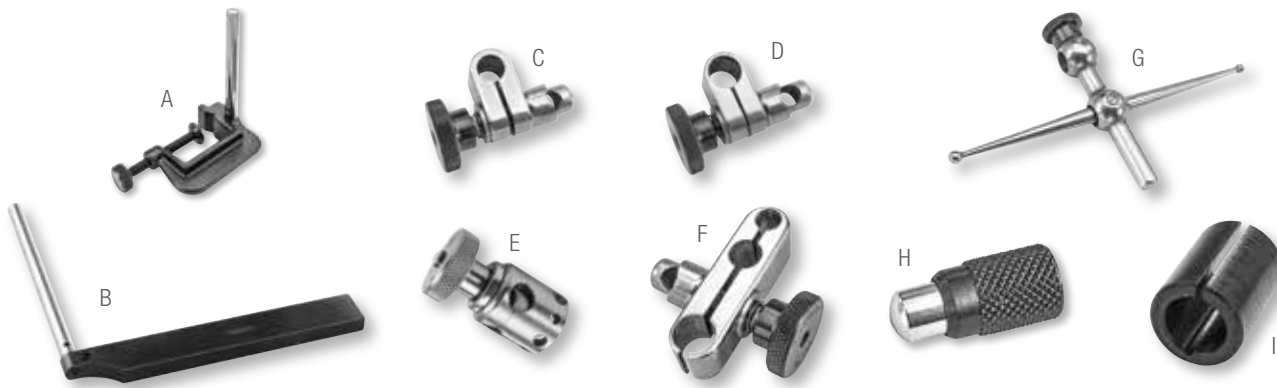

Attachments for 650, 651, 196 and 196M Back Plunger Dial Indicators and Universal Dial Indicators

| Photo Key | Cat./Part No. | EDP | Description |
|-----------|---------------|-------|---|
| A* | PT99437 | 64492 | Clamp |
| B* | PT99438 | 64493 | Tool Post Holder |
| C* | PT18718 | 50709 | Snug Complete |
| D | PT18724 | 50710 | Snug Complete - 1/4" and 3/8" Holes |
| E | 57S | 50296 | Universal Snug |
| F | 58S | 56613 | |
| G* | 196F | 50706 | Hole Attachment for 196 and 196M Only |
| H | PT08726A | 66052 | Shock Absorbing Anvil for 196 and 196M Only |
| I | PT00764 | 68850 | Split Bushing for 196 and 196M Only |

Attachments marked with an asterisk () are furnished with all sets having "A" in the catalog number.
 †For snug with 8mm post hole diameter and 2.4-6.3mm holding capacity, order PT27171, EDP 66457.

ATTACHMENTS FOR 196 AND 196M ONLY

G. HOLE ATTACHMENT

196F. allows indicator be used over obstructions and inside holes to a depth of approximately 1-5/8" (40mm).

H. SHOCK ABSORBING ANVIL

PT08726A.

I. SPLIT BUSHING

PT00764. Allows attachment of 196 Indicator to 660 Magnetic Base.



DIAL INDICATORS

MECHANICAL DIAL INDICATORS AND ATTACHMENTS

ELECTRONIC INDICATORS/INDICATOR HOLDERS

Accurate, rugged, versatile, convenient to use and inexpensive – for these reasons and more, mechanical dial indicators with bottom plungers are the measurement workhorses of industrial production.

Electronic indicators have an unmatched ability for the accurate recording of a great amount of measurement data which is used in a variety of Statistical Process Control (SPC) operations.

The first part of this section shows our complete line of mechanical/analog dial indicators – over 180 models to give you the widest selection in the industry. Our comparison guide, following these introduction pages, has all the significant specifications to help you make your selection.

COMPARING AGD DESIGN SPECIFICATIONS WITH OTHERS

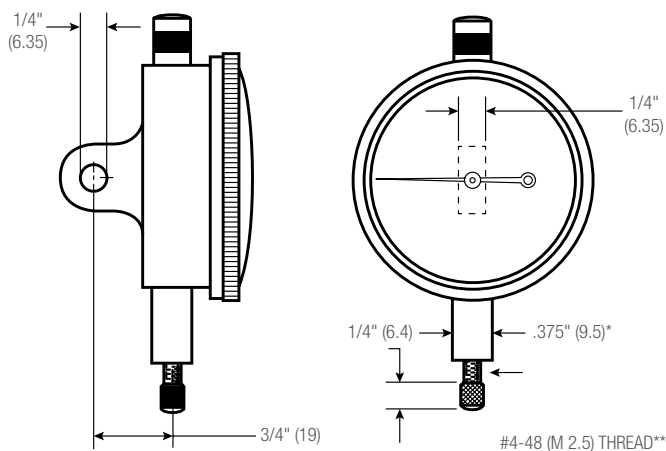

*There are two major differences between American Gage Design and other specifications. The first is the stem diameter. AGD specifies .375" (9.5mm) and some other standards specify an 8mm (.315") diameter. International specifications allow for either one and we can furnish both diameters. The .375" (9.5mm) diameter provides a little more protection for the rack when clamped on the stem – 8mm stems are available on any model, please specify when ordering.

** The other difference is the contact thread. AGD specifies a #4-48 thread. Other standards specify a metric thread, #M2.5.

APPLICATION SPECIFICATION FACTORS

1. Regular analog styles with indicating hands are more readable than digital styles when the measurements are being visually monitored by an operator.
2. Select the dial size that gives you the readability you need. We offer five regular dial sizes which will fit most applications that have both space limitations and readability requirements.
3. Choose the accuracy and readout you need – don't select a .0001" (or 0.001mm) readout if .001" (or 0.01mm) will do your job.
4. Electronic styles are best when the measurement data needs to be collected, printed out or stored for future use.
5. Consider any special features you may need – inch or millimeter reading, special shockless movement, antimagnetic, long range, long stem, special backs, special contacts, special holders, etc. If you don't see what you need, please contact our Special Order Department. Even though we have a broad line of indicators to tackle most jobs, we also do a lot of special design, catering to the specific needs of our customers – challenge us!
6. Starrett indicators are made to American Gage Design Specifications (AGD). These specifications were developed in 1945 at the request of the U.S. Commerce Department through the National Bureau of Standards – now the National Institute of Standards and Technology (NIST). These specifications provide the dimensions to allow interchangeability between indicators of different manufacturers in fixturing. As you will see, these dimensions pertain to sizes for space consideration and for holding. Other countries have made their own design specifications which we can also furnish. However, the AGD design is probably more widely used, simply because it was the first standard created.
7. Basically, all dial indicators used worldwide fall into the following size ranges which relate to bezel diameters. Size 0 is a smaller dial indicator, having its own dimensions. Sizes 1 through 4 are AGD sizes. These sizes and the AGD dimensions are essentially the same for all manufacturers, except as noted.
8. Accuracy – All indicators should be "loaded" 1/8-1/4 of a turn before testing or measuring. Starrett dial indicators meet or exceed all known performance specifications. Most accuracies are specified plus or minus one graduation over the full range. This basically means a 2-1/2 turn range. Longer ranges have slightly wider tolerances. Starrett indicators are at least that accurate, but we are better than that in the final critical measuring zone of "10 o'clock to 2 o'clock" from zero. AGD specifies 2-1/3 turn indicators to cover any particular range. The reason for this is that in an effort to get the most out of the indicator, the operator "loads" it to about 1-1/3 turns and sets zero on his master. The indicator will now show the accurate deviation for a full revolution, plus or minus.



DIAL INDICATORS

DESIGN FEATURES

- Rugged and simple unit construction with a "universally fitting" design as shown
- One gear unit assembly fits AGD Group 2 (our 25 Indicators), AGD Group 3 (our 655 Indicators) and AGD Group 4 (our 656 Indicators)
- The gear unit is constructed of a massive single bridge and plate assembly with a hardened stainless steel gear train
- All gear trains are fully jeweled for sensitivity, smoothness and life. (We do provide 1/2" and 1" range models with plain bronze bearings)
- The case is light but sturdy, with a hardened, precision stainless steel rack that rides in bronze bushings. Size Groups 0 and 1 indicators are of similar construction but smaller in size.
- Hardened stainless steel bottom stems can be held in fixtures without cramping rack action
- Easy readability with the best, balanced style of graduation and number combination. (Too thick and accuracy suffers; too thin and readability suffers)
- Balanced and tapered hands are easy to follow
- Special non-shock mechanism (can be furnished on most styles) is ideal for when an indicator may be subjected to repeated and excessive shocks

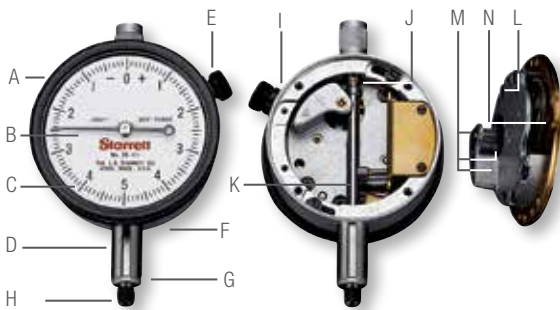

- A. Sharp bezel serrations for positive grip
- B. Non-reflecting white eggshell finish on dial (millimeter models have yellow dials)
- C. Unbreakable crystal
- D. Hardened stainless steel stem
- E. Positive-acting clamp locks bezel in position
- F. No-glare satin finish on case
- G. .375" mounting diameter (all AGD models)
- H. Interchangeable contact point
- I. Four screw holes for 90° rotation of back
- J. Direct acting compression spring eliminates side friction
- K. Hardened stainless steel rack and spindle
- L. Massive bridge for rigid bearing support
- M. Replaceable low friction jewel bearings
- N. Hardened stainless steel gears and pinions

DIALS, ACCESSORIES AND OPTIONS

Balanced or Continuous Dials – Starrett AGD indicators are furnished with a balanced dial (plus on right). A continuous dial (reading clockwise) may also be ordered.

Plus and Minus Graduations – Plus and minus readout – black figures read clockwise, red figures read counterclockwise, or colors reversed – are available on some 81 Dial Indicators.

Revolution Counters – All AGD indicators with 2-1/2 revolutions can be furnished with double dial and count hand at a slight additional cost. Intermediate and long-range indicators have revolution counters

Special Dials – Starrett dial indicators can be furnished with any standard dial

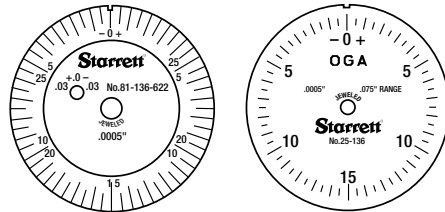

Far Left: Dial with Plus and Minus Graduations
Left: Dial with Special Trademark Imprint

marked with your company name or trademark. No charge when the indicators are purchased in lots of 25 or more. For quantities under 25, there is an additional charge. Prices are available on request.

Antimagnetic Mechanism – An antimagnetic mechanism can be furnished on most 81, 25, 655, 656, 196B6 Dial Indicators. This mechanism is desirable when the indicator is used near a magnetic chuck or a similar magnetic field which would disturb its operation. See individual listings for availability.

Attachments and Accessories – A variety of attachments and accessories are provided for mounting dial indicators on machine tools, inspection equipment and special fixtures, including:

- Backs
- Contact Points
- Dust Guard
- Hole Attachments
- Special Non-shock mechanism
- Spindle Travel Controls
- Stem and Back Mounting Accessories
- Tolerance and Maximum Reading Hands



Gear Unit

+



Case Assembly

=



Complete Indicator



DIAL INDICATORS

80 MINIATURE DIAL INDICATORS AND ACCESSORIES

ANSI GROUP 0

RANGES UP TO .100"

1-1/4" BEZEL, 7/32" STEM

Similar in design to AGD dial indicators, these miniatures are built for gaging dimensions in tight places. Equipped with high precision, low friction movements, they are made in four models, all with frictionally adjustable bezels for quick, positive zero setting. No-glare, white eggshell finish dials. Black bezel, silver finish on case. Furnished with balanced dial, jeweled bearings and lug-on-center back.

80SB split bushing available .219" to 3/8".

Dimensions with lug-on-center back

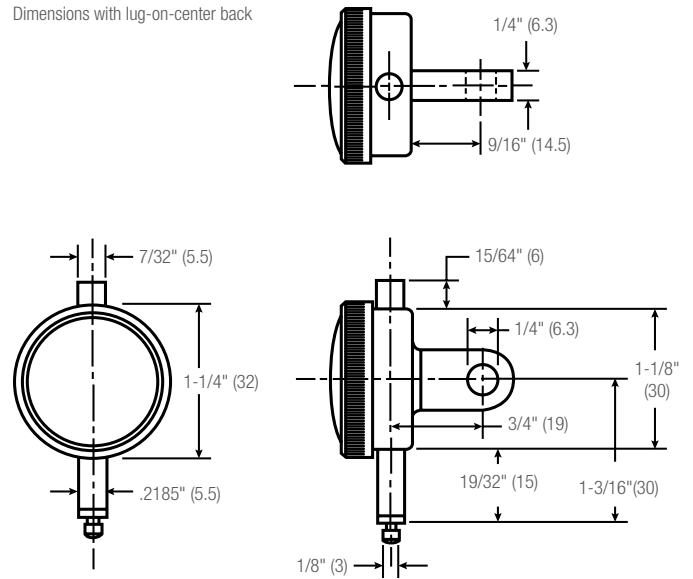

Free drafting template available for this size.

Write The L. S. Starrett Co. at:
121 Crescent Street
Athol, MA 01331.

80 Miniature Dial Indicators

| Cat. No. | EDP | Graduation | Range One Rev. | Total | Dial Reading |
|----------|-------|------------|----------------|-------|--------------|
| 80-114J | 55891 | .0001" | .004" | .010" | 0-2-0 |
| 80-111J | 67714 | .010" | .010" | .025" | 0-5-0 |
| 80-134J | 55892 | .0005" | .020" | .050" | 0-10-0 |
| 80-144J | 55893 | .001" | .040" | .100" | 0-20-0 |



80-114J



80-134J



80-144J



CONTACT POINTS

The regular contact point is furnished standard on all 80 Dial Indicators. Button, cone and flat contact points are available individually, as listed. All have #0-80 thread.

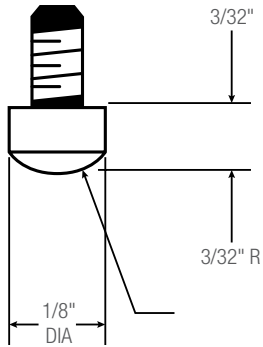

PT25044 Regular Contact Point
(Standard on all 80 Dial Indicators)

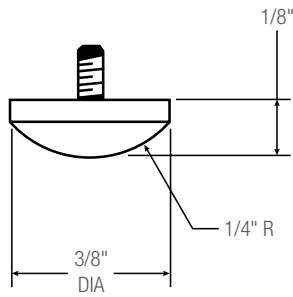

PT25159 Button Contact Point

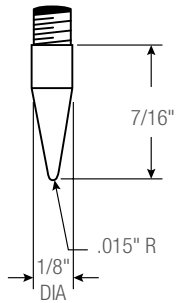

PT25161 Cone Contact Point

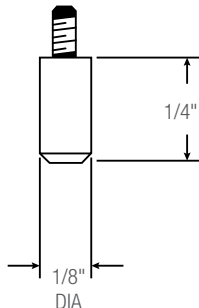

PT25160 Flat Contact Point

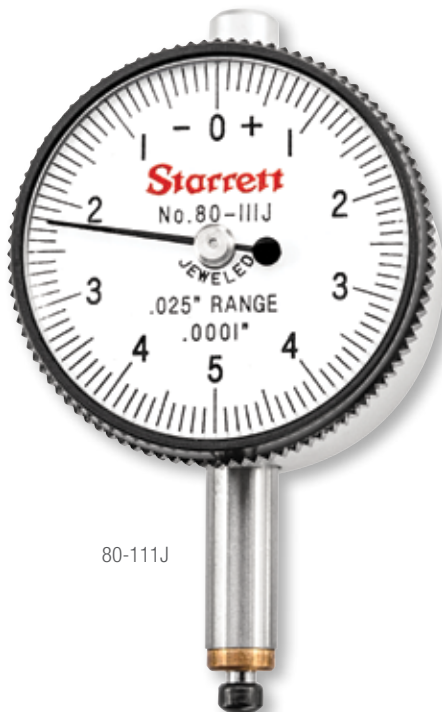

80-111J

BACKS

The lug-on-center back is furnished standard on all 80 Dial Indicators.

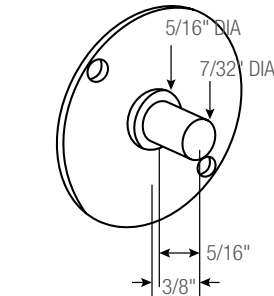

PT25158 Post-Type Lug Back

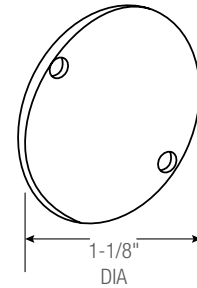

PT25079 Flat Back

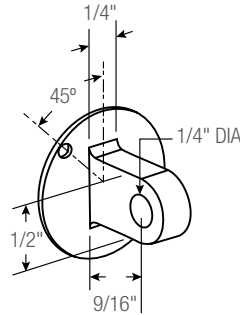

PT25053 Lug-on-Center Back
(Standard on all 80 Dial Indicators)

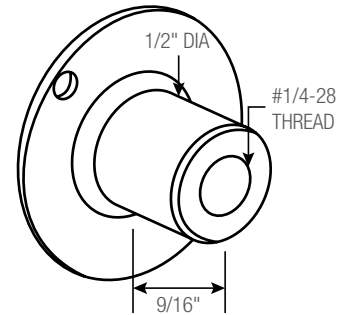

PT25071 Screw-Type Lug Back

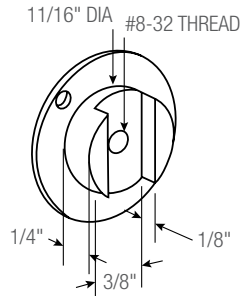

PT25157 Adjustable Bracket Back

NOTE: Contact points and backs can be ordered individually. Order by part number/EDP number.

| Part No. | EDP | Description |
|----------|-------|-------------------------|
| PT25044 | 72023 | Regular Contact Point |
| PT25159 | 72024 | Button Contact Point |
| PT25161 | 72025 | Cone Contact Point |
| PT25160 | 72026 | Flat Contact Point |
| PT25079 | 72028 | Flat Back |
| PT25071 | 72030 | Screw-Type Lug Back |
| PT25053 | 72027 | Lug-on Center Back |
| PT25157 | 72029 | Adjustable Bracket Back |
| PT25158 | 72031 | Post-Type Lug Back |



DIAL INDICATORS

81, 25, 655 AND 656 AGD DIAL INDICATORS

This comparison table is an aid to help you find the indicator with the specific graduations and ranges you are looking for. Refer to the following pages for the exact catalog number and EDP number.

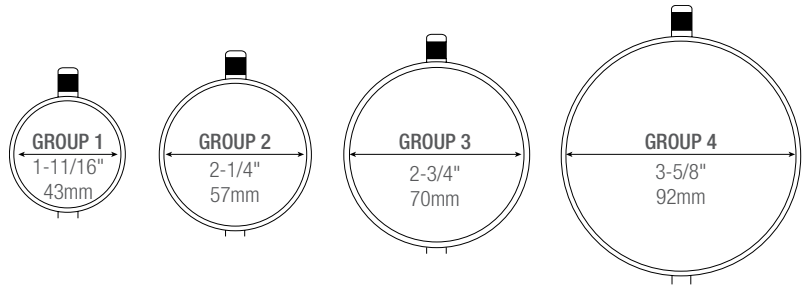

81, 25, 655 and 656 AGD Dial Indicators (White Dials Furnished Standard)

| Graduation | Range One Rev. | Total | Dial Reading | Group 1 81 Indicators | Group 2 25 Indicators | Group 3 655 Indicators | Group 4 656 Indicators |
|------------|-------------------|--------|------------------------------|----------------------------|--------------------------|---------------------------|---------------------------|
| .00005" | .006" | .015" | 0-3-0 0-6 | | 25-109 25-209 | | 656-109 656-209 |
| .0001" | .006" | .015" | 0-3-0 | | 25-116 | | |
| .0001" | .008" | .020" | 0-4-0 0-8 | | 25-118 25-218 | 655-118 | 656-118 |
| .0001" | .010" | .025" | 0-5-0 0-10 | 81-111 81-211 | 25-111 25-211 | 655-111 655-211 | 656-111 656-211 |
| .0001" | .010" | .025" | 0.1 -0.10 -0.10 0.1 | 81-111-624* 81-111-630* | | | |
| .0001" | .010" | .200" | 0-5-0 0-10 | | 25-511* 25-611* | 655-511* 655-611* | 656-511* 656-611* |
| .0001" | .020" | .400" | 0-10-0 0-20 | | | | 656-517* 656-617* |
| .00025" | .010" | .025" | 0-5-0 0-10 | 81-124 81-224 | 25-124 25-224 | 655-124 655-224 | 656-124 656-224 |
| .00025" | .020" | .050" | 0-10-0 0-20 | 81-128 81-228 | 25-128 25-228 | 655-128 655-228 | 656-128 656-228 |
| .00025" | .030" | .075" | 0-15-0 0-30 | | | 655-129 655-229 | 656-129 656-229 |
| .0005" | .020" | .050" | 0-10-0 0-20 | 81-134 81-234 | 25-134 25-234 | 655-134 655-234 | 656-134 656-234 |
| .0005" | .030" | .075" | 0-15-0 0-30 | 81-136 81-236 | 25-136 25-236 | 655-136 655-236 | 656-136 656-236 |
| .0005" | .030" | .075" | 0.3 -0.30 -0.30 0.3 | 81-136-622* 81-136-623* | | | |
| .0005" | .040" | .100" | 0-20-0 0-40 | 81-138 81-238 | 25-138 25-238 | 655-138 655-238 | 656-138 656-238 |
| .0005" | .050" | .125" | 0-25-0 0-50 | 81-131 81-231 | 25-131 25-231 | 655-131 655-231 | 656-131 656-231 |
| .0005" | .050" | .500" | 0-50 | | 25-431** | | |
| .0005" | .050" | 1.000" | 0-50 | | 25-631** | | |

* With revolution counter on dial

† With top lift mechanism

AGD Design Specifications: Bezel Diameters

| Design | Size Group | Minimum Diameter | | Maximum Diameter | |
|--------|------------|------------------|------|------------------|------|
| | | in | mm | in | mm |
| AGD | 0 | 1" | 25mm | 1-3/8" | 35mm |
| | 1 | 1-3/8" | 35mm | 2" | 50mm |
| | 2 | 2" | 50mm | 2-3/8" | 60mm |
| | 3 | 2-3/8" | 60mm | 3" | 75mm |
| | 4 | 3" | 76mm | 3-3/4" | 95mm |



81, 25, 655 and 656 AGD Dial Indicators (White Dials Furnished Standard)

| Graduation | Range | | Dial Reading | Group 1 81 Indicators | Group 2 25 Indicators | Group 3 655 Indicators | Group 4 656 Indicators |
|------------|----------|---------|------------------------------|----------------------------|--------------------------|---------------------------|---------------------------|
| | One Rev. | Total | | | | | |
| .001" | .020" | .050" | 0-10-0 0-20 | 81-142 81-242 | 25-142 25-242 | 655-142 655-242 | 656-142 656-242 |
| .001" | .030" | .075" | 0-15-0 0-30 | 81-143 81-243 | 25-143 25-243 | 655-143 655-243 | 656-143 656-243 |
| .001" | .030" | .075" | +0.30, -0.30 -0.30, +0.30 | 81-143-628* 81-143-629* | | | |
| .001" | .040" | .100" | 0-20-0 0-40 | 81-144 81-244 | 25-144 25-244 | 655-144 655-244 | 656-144 656-244 |
| .001" | .050" | .125" | 0-25-0 0-50 | 81-145 81-245 | 25-145 25-245 | 655-145 655-245 | 656-145 656-245 |
| .001" | .100" | .250" | 0-50-0 0-100 | 81-141 81-241 | 25-141 25-241 | 655-141 655-241 | 656-141 656-241 |
| .001" | .100" | .500" | 0-50-0 0-100 | | 25-341/5*† 25-441/5*† | 655-341/5* 655-441/5* | 656-341/5* 656-441/5* |
| .001" | .100" | 1.000" | 0-50-0 0-100 | | 25-341** 25-441** | 655-341** 655-441** | 656-341** 656-441** |
| .001" | .100" | 2.000" | 0-100 | | 25-2041* | 655-2041* | 656-2041* |
| | | 3.000" | | | 25-3041* | 655-3041* | 656-3041* |
| | | 4.000" | | | 25-4041* | 655-4041* | 656-4041* |
| | | 5.000" | | | 25-5041* | 655-5041* | 656-5041* |
| | | 6.000" | | | | | 656-6041* |
| | | 7.000" | | | | | 656-7041* |
| | | 8.000" | | | | | 656-8041* |
| | | 9.000" | | | | | 656-9041* |
| | | 10.000" | | | | | 656-10041* |
| | | 11.000" | | | | | 656-11041* |
| 12.000" | | | 656-12041* | | | | |

81, 25, 655 and 656 AGD Dial Indicators (Yellow Dials Furnished Standard)

| Graduation | Range | | Dial Reading | Group 1 81 Indicators | Group 2 25 Indicators | Group 3 655 Indicators | Group 4 656 Indicators |
|------------|----------|--------|-----------------|--------------------------|--------------------------|---------------------------|---------------------------|
| | One Rev. | Total | | | | | |
| 0.001mm | 0.1mm | 0.25mm | 0-50-0 0-100 | | 25-151* 25-251* | | |
| 0.002mm | 0.2mm | 0.5mm | 0-10-0 0-20 | 81-161 81-261 | 25-161 25-261 | 655-161 655-261 | 656-161 656-261 |
| 0.01mm | 1mm | 2.5mm | 0-50-0 0-100 | 81-181 81-281 | 25-181 25-281 | 655-181 655-281 | 656-181 656-281 |
| 0.01mm | 1mm | 10mm | 0-50-0 0-100 | | 25-381** 25-481* | | |
| 0.01mm | 1mm | 25mm | 0-50-0 0-100 | | 25-781** 25-881** | 655-881** | 656-881** |
| 0.01mm | 1mm | 50mm | 0-100 | | 25-2081* | 655-2081* | |
| 0.01mm | 1mm | 75mm | 0-100 | | 25-3081* | 655-3081* | |
| 0.01mm | 1mm | 100mm | 0-100 | | 25-4081* | 655-4081* | |
| 0.01mm | 1mm | 125mm | 0-100 | | 25-5081* | 655-5081* | |

* With revolution counter on dial

† With top lift mechanism



DIAL INDICATORS

STARRETT DIAL NUMBERING AND LINE STYLES FOR DIAL INDICATORS

These next three pages include all Starrett dial styles. (Actual size not shown.) Refer to the graduation, then range, and catalog number below the dial and then see the following pages for the specific dial reading and other indicator information. Most of the dials shown have balanced styles. Continuous dials have the same graduations, but have consecutive numbers instead. For most indicators, the first number after the base catalog number signifies dial style. The number "1" signifies balanced dials (example: 25-109) and number "2" signifies continuous dials (example: 25-209).

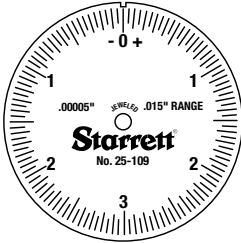

| .00005" Graduation | |
|--------------------|-------------------|
| Total Range | .015" |
| Cat. No. | 25-109 656-109 |

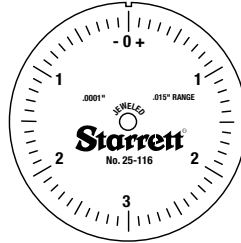

| .0001" Graduation | | | |
|-------------------|------------------------------|------------------------------|--|
| Total Range | .015" | .020" | .025" |
| Cat. No. | 25-116 655-118 656-118 | 25-118 655-118 656-118 | 25-111 80-111 81-111 655-111 656-111 |

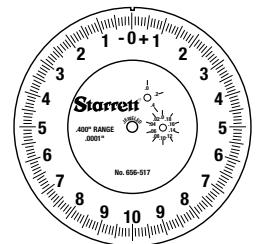
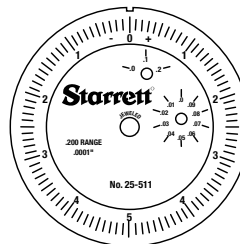
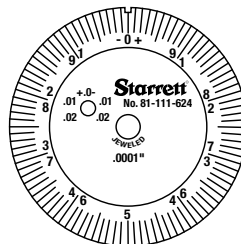
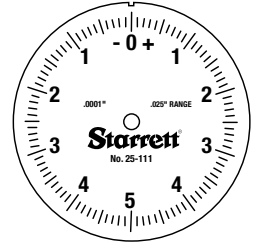
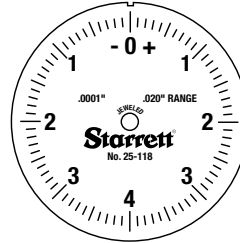

| .0001" Graduation | | | |
|-------------------|--------------------------------------|------------------------------|---------|
| Total Range | .025" | .200" | .400" |
| Cat. No. | 81-111-624 (with double row figures) | 25-511 655-511 656-511 | 656-517 |

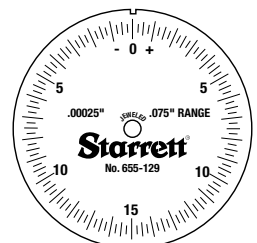
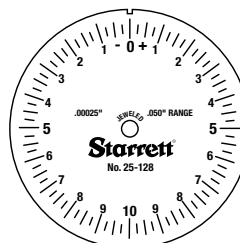
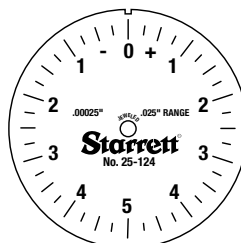

| .00025" Graduation | | | |
|--------------------|--|--|--------------------|
| Total Range | .025" | .050" | .075" |
| Cat. No. | 81-124 25-124 655-124 656-124 | 81-128 25-128 655-128 656-128 | 655-129 656-129 |



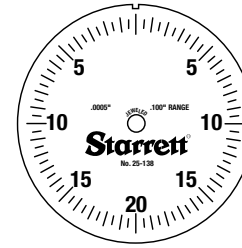
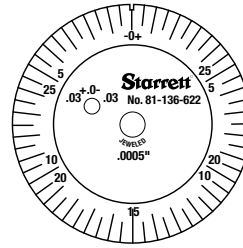
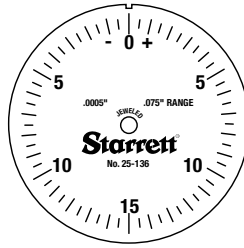
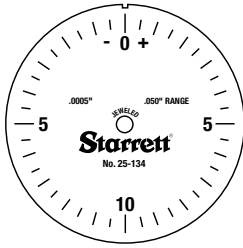

.0005" Graduation

| | | | | |
|--------------------|--|--|--------------------------------------|--|
| Total Range | .050" | .075" | .075" | .100" |
| Cat. No. | 81-134 25-134 655-134 656-134 | 81-136 25-136 655-136 656-136 | 81-136-622 (with double row figures) | 81-138 25-138 655-138 656-138 |

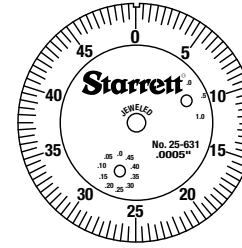
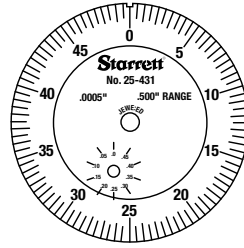
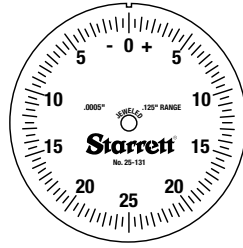

.0005" Graduation

| | | | |
|--------------------|--|--------|--------|
| Total Range | .125" | .500" | 1.000" |
| Cat. No. | 81-131 25-131 655-131 656-131 | 25-431 | 25-631 |

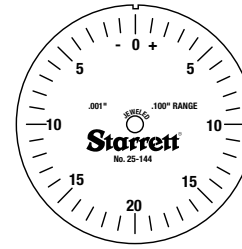
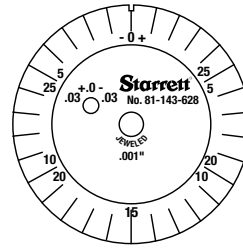
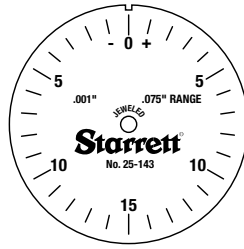
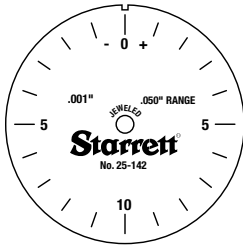

.001" Graduation

| | | | | |
|--------------------|---|--|--------------------------------------|---------------------------------|
| Total Range | .050" | .075" | .075" | .100" |
| Cat. No. | 81-142 81-144 *25-142 *655-142 *656-142 | 81-143 25-143 655-143 656-143 | 81-143-628 (with double row figures) | *25-144 *655-144 *656-144 |

* Also on long range models.

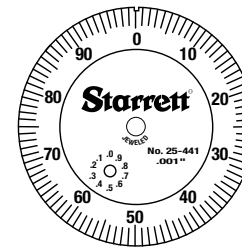
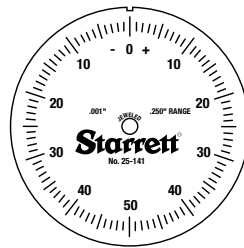
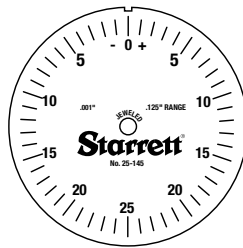

.001" Graduation

| | | | |
|--------------------|---|---|--|
| Total Range | .125" | .250" | .500", 1.000" |
| Cat. No. | 81-145 *25-145 *655-145 *656-145 | 81-141 *25-141 *655-141 *656-141 | 25-441, 25-441/5 655-441, 655-441/5 656-441, 656-441/5 |

* Also on long range models.



DIAL INDICATORS

STARRETT DIAL NUMBERING AND LINE STYLES FOR DIAL INDICATORS

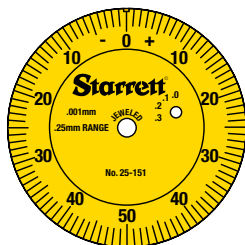

| 0.001mm Graduation | |
|--------------------|--------|
| Total Range | .25mm |
| Cat. No. | 25-151 |

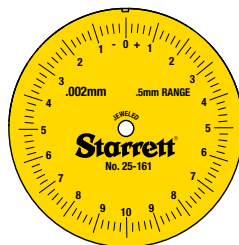

| 0.002mm Graduation | |
|--------------------|---|
| Total Range | 0.5mm |
| Cat. No. | No.81-161 25-161 655-161 656-161 |

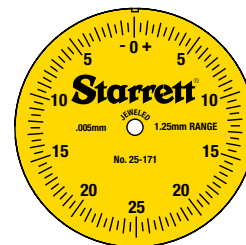

| 0.005mm Graduation | |
|--------------------|--------|
| Total Range | 1.25mm |
| Cat. No. | 25-171 |

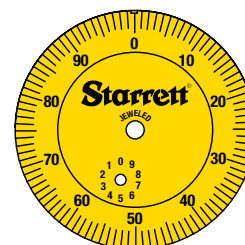
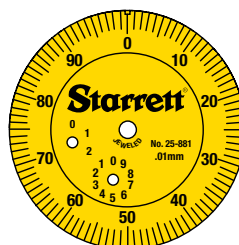
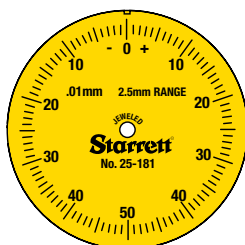

| 0.01mm Graduation | | | | |
|-------------------|---------|---------|--------|--------------------|
| Total Range | 2.5mm | 25mm | 10mm | 50, 75, 100, 125mm |
| | 81-181 | 25-881 | 25-381 | 25-2081 |
| Cat. No. | 25-181 | 655-881 | | 25-3081 |
| | 655-181 | 656-881 | | 25-4081 |
| | 656-181 | | | 25-5081 |
| | | | | |



DIAL INDICATORS

81 DIAL INDICATORS

AGD GROUP 1

RANGES UP TO .250" AND 2.5MM

These Indicators have a shockless, hardened steel gear train and jewel bearings. They are furnished with a lug-on-center back. Antimagnetic and special non-shock mechanisms are options available for all models. For more information on these and other attachments, accessories and contact points, refer to the end of the AGD Dial Indicator listings. For dial styles, see previous pages.

If lift lever is desired, indicator must be ordered with case stem cap.



81-141J



81-161J

81 Dial Indicators

| Cat. No. | EDP | Graduation | Range One Rev. | Total | Dial Reading |
|----------|-------|------------|----------------|-------|--------------|
| 81-111J | 53378 | .0001" | .010" | .025" | 0-5-0 |
| 81-211J | 53414 | | | | 0-10 |
| 81-124J | 53384 | .00025" | .010" | .025" | 0-5-0 |
| 81-224J | 53416 | | | | 0-10 |
| 81-128J | 53386 | .00025" | .020" | .050" | 0-10-0 |
| 81-228J | 53418 | | | | 0-20 |
| 81-134J | 53390 | .0005" | .020" | .050" | 0-10-0 |
| 81-234J | 53422 | | | | 0-20 |
| 81-136J | 53392 | .0005" | .030" | .075" | 0-15-0 |
| 81-236J | 53424 | | | | 0-30 |
| 81-138J | 53398 | .0005" | .040" | .100" | 0-20-0 |
| 81-238J | 53426 | | | | 0-40 |
| 81-131J | 53388 | .0005" | .050" | .125" | 0-25-0 |
| 81-231J | 53420 | | | | 0-50 |
| 81-142J | 53402 | .001" | .020" | .050" | 0-10-0 |
| 81-242J | 53430 | | | | 0-20 |
| 81-143J | 53404 | .001" | .030" | .075" | 0-15-0 |
| 81-243J | 53432 | | | | 0-30 |
| 81-144J | 53408 | .001" | .040" | .100" | 0-20-0 |
| 81-244J | 53434 | | | | 0-40 |
| 81-145J | 53410 | .001" | .050" | .125" | 0-25-0 |
| 81-245J | 53436 | | | | 0-50 |
| 81-141J | 53400 | .001" | .100" | .250" | 0-50-0 |
| 81-241J | 53428 | | | | 0-100 |

81 Dial Indicators

| Cat. No. | EDP | Graduation | Range One Rev. | Total | Dial Reading | Stem Dia. |
|-----------|-------|------------|----------------|-------|--------------|-------------|
| 81-161J | 56043 | 0.002mm | 0.2mm | 0.5mm | 0-10-0 | .375" (8mm) |
| 81-161J-8 | 64643 | | | | | |
| 81-261J | 56045 | 0.002mm | 0.2mm | 0.5mm | 0-20 | .375" (8mm) |
| 81-261J-8 | 64644 | | | | | |
| 81-181J | 53412 | 0.01mm | 1.0mm | 2.5mm | 0-50-0 | .375" (8mm) |
| 81-181J-8 | 64645 | | | | | |
| 81-281J | 53438 | 0.01mm | 1.0mm | 2.5mm | 0-100 | .375" (8mm) |
| 81-281J-8 | 64646 | | | | | |



DIAL INDICATORS

81 DIAL INDICATORS WITH DOUBLE ROW FIGURES

AGD GROUP 1

RANGES UP TO .075"

These indicators have the exact same features as our 81 Dial Indicators on the previous page, except the dials have double-row figures, as illustrated, and they cannot be specified with a special non-shock mechanism.

If lift lever is desired, indicator must be ordered with case stem cap.

81 Dial Indicators with Double Row Figures

| Cat. No. | EDP | Graduation | Dial Reading | Figures Direction | Color | Range One Rev. | Total |
|-------------|-------|------------|--------------|--------------------------------|--------------|----------------|-------|
| 81-111-624J | 53380 | .0001" | -10 -0-10 | Clockwise Counter-clockwise | Black Red | .010" | .025" |
| 81-111-630J | 53382 | .0001" | -10 -0-10 | Counter-clockwise Clockwise | Black Red | .010" | .025" |
| 81-136-622J | 53394 | .0005" | -30 -0-30 | Clockwise Counter-clockwise | Black Red | .030" | .075" |
| 81-136-623J | 53396 | .0005" | -30 -0-30 | Counter-clockwise Clockwise | Black Red | .030" | .075" |
| 81-143-628J | 53406 | .001" | -30 -0-30 | Clockwise Counter-clockwise | Black Red | .030" | .075" |
| 81-143-629J | 66666 | .001" | -30 -0-30 | Counter-clockwise Clockwise | Black Red | .030" | .075" |

Other models with double-row figures can be furnished by request.



81-111-624J

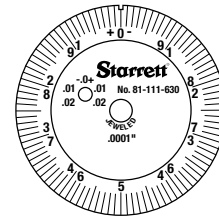
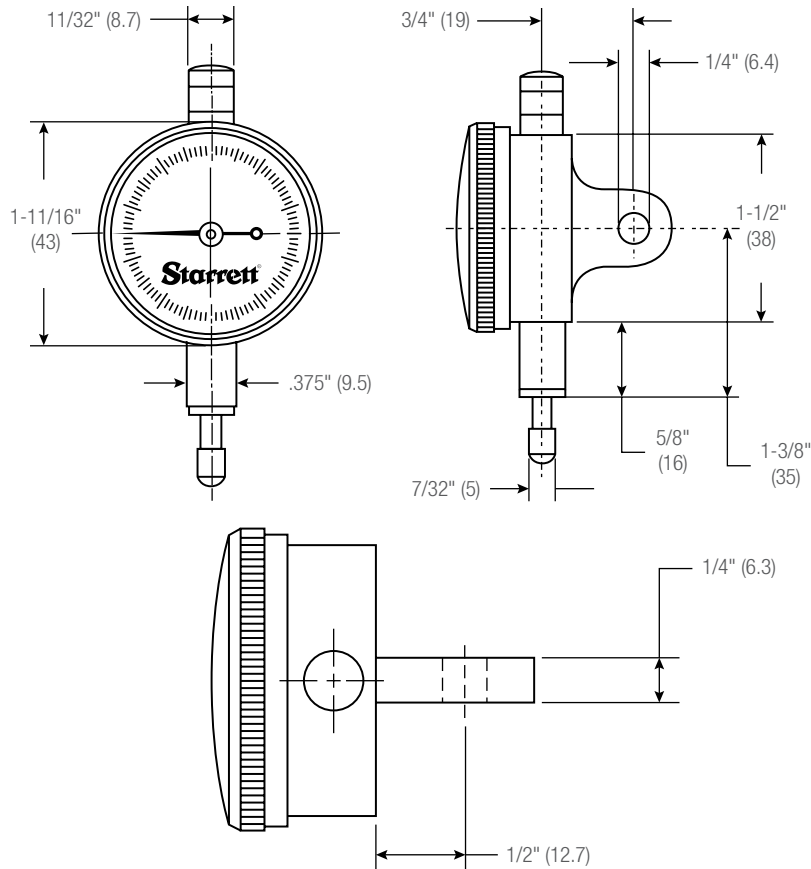

81-111-630J

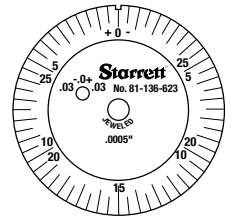

81-136-623J

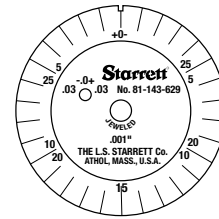

81-143-629J

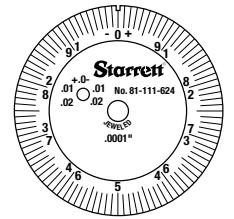

81-111-624J

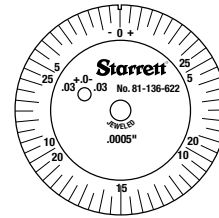

81-136-622J

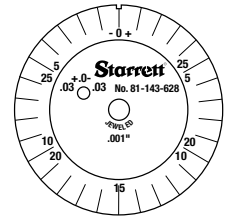

81-143-628J

Free drafting template available for this size.

Write The L. S. Starrett Co. at:
121 Crescent Street
Athol, MA 01331



DIAL INDICATORS

25 DIAL INDICATORS

AGD GROUP 2

RANGES UP TO 1" AND 25MM

These indicators have a shockless, hardened steel gear train and jewel bearings, except where noted. They are furnished with a lug-on-center back. Antimagnetic mechanism is optional for all models. Special non-shock mechanism is available for all models except 25-109, 25-209 and 25-116. For more information on these and other attachments, accessories and contact points, refer to the end of the AGD Dial Indicator listings. For dial styles, see previous pages.

If lift lever is desired, indicator must be ordered with case stem cap.



25-111J



25-161J

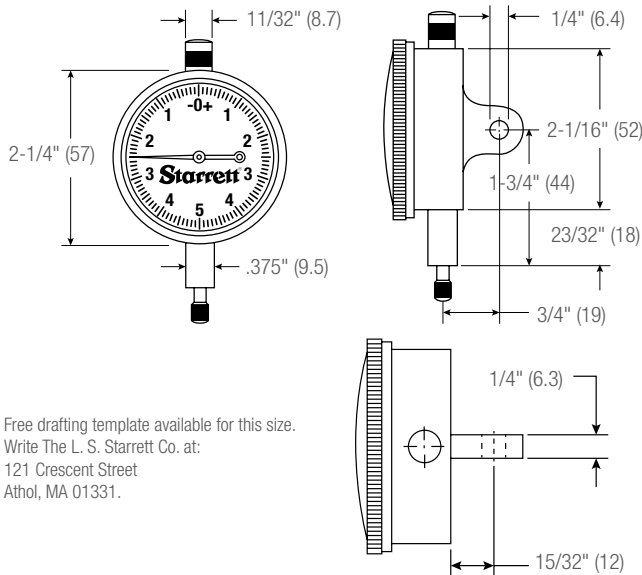

Free drafting template available for this size. Write The L. S. Starrett Co. at: 121 Crescent Street Athol, MA 01331.

25-441J with top lift

656-129J case stem cap design required for use with lift lever See page 171



25 Dial Indicators with Jewel Bearings

| Cat. No. | EDP | Graduation | Range One Rev. | Total | Dial Reading | Stem Dia. |
|-----------|-------|------------|----------------|--------|--------------|---------------|
| 25-151J | 67644 | | 0.1mm | 0.25mm | 0-50-0 | .375" (9.5mm) |
| 25-151J-8 | 68646 | 0.001mm | 0.1mm | 0.25mm | 0-100 | .375" (9.5mm) |
| 25-251J | 68118 | | 0.1mm | 0.25mm | 0-10-0 | .375" (9.5mm) |
| 25-251J-8 | 68647 | 0.001mm | 0.1mm | 0.25mm | 0-10-0 | .375" (9.5mm) |
| 25-161J | 53250 | | 0.2mm | 0.5mm | 0-10-0 | .375" (9.5mm) |
| 25-161J-8 | 64651 | 0.002mm | 0.2mm | 0.5mm | 0-10-0 | .375" (9.5mm) |
| 25-261J | 53281 | | 0.2mm | 0.5mm | 0-20 | .375" (9.5mm) |
| 25-261J-8 | 64652 | 0.002mm | 0.2mm | 0.5mm | 0-20 | .375" (9.5mm) |
| 25-171J | 68643 | | 0.5mm | 1.25mm | 0-25-0 | .375" |
| 25-181J | 53252 | | 1.0mm | 2.5mm | 0-50-0 | .375" (9.5mm) |
| 25-181J-8 | 64653 | 0.01mm | 1.0mm | 2.5mm | 0-100 | .375" (9.5mm) |
| 25-281J | 53283 | | 1.0mm | 2.5mm | 0-100 | .375" (9.5mm) |
| 25-281J-8 | 64654 | 0.01mm | 1.0mm | 2.5mm | 0-100 | .375" (9.5mm) |
| 25-381J | 53289 | | 1.0mm | 10mm | 0-50-0 | .375" (9.5mm) |
| 25-381J-8 | 64655 | 0.01mm | 1.0mm | 10mm | 0-50-0 | .375" (9.5mm) |
| 25-481J | 53297 | | 1.0mm | 10mm | 0-100 | .375" (9.5mm) |
| 25-481J-8 | 64656 | 0.01mm | 1.0mm | 10mm | 0-100 | .375" (9.5mm) |
| 25-781J | 53305 | | 1.0mm | 25mm | 0-50-0 | .375" (9.5mm) |
| 25-781J-8 | 64657 | 0.01mm | 1.0mm | 25mm | 0-50-0 | .375" (9.5mm) |
| 25-881J | 53307 | | 1.0mm | 25mm | 0-100 | .375" (9.5mm) |
| 25-881J-8 | 64658 | 0.01mm | 1.0mm | 25mm | 0-100 | .375" (9.5mm) |

25 Dial Indicators with Jewel Bearings

| Cat. No. | EDP | Graduation | Range One Rev. | Total | Dial Reading |
|------------------|-------|------------|----------------|--------|--------------|
| 25-109J | 53222 | .00005" | .006" | .015" | 0-3-0 |
| 25-209J | 53254 | .00005" | .006" | .015" | 0-6 |
| 25-116J | 53225 | .0001" | .006" | .015" | 0-3-0 |
| 25-118J | 53226 | .0001" | .008" | .020" | 0-4-0 |
| 25-218J | 53257 | .0001" | .008" | .020" | 0-8 |
| 25-111J | 53223 | .0001" | .010" | .025" | 0-5-0 |
| 25-211J | 53255 | .0001" | .010" | .025" | 0-10 |
| 25-511J | 53299 | .0001" | .010" | .200" | 0-5-0 |
| 25-611J | 53301 | .0001" | .010" | .200" | 0-10 |
| 25-124J | 53228 | .00025" | .010" | .025" | 0-5-0 |
| 25-224J | 53259 | .00025" | .010" | .025" | 0-10 |
| 25-128J | 53230 | .00025" | .020" | .050" | 0-10-0 |
| 25-228J | 53261 | .00025" | .020" | .050" | 0-20 |
| 25-134J | 53234 | .0005" | .020" | .050" | 0-10-0 |
| 25-234J | 53265 | .0005" | .020" | .050" | 0-20 |
| 25-136J | 53236 | .0005" | 0.03 | .075" | 0-15-0 |
| 25-236J | 53267 | .0005" | 0.03 | .075" | 0-30 |
| 25-138J | 53238 | .0005" | .040" | .100" | 0-20-0 |
| 25-238J | 53269 | .0005" | .040" | .100" | 0-40 |
| 25-131J | 53232 | .0005" | .050" | .125" | 0-25-0 |
| 25-231J | 53263 | .0005" | .050" | .125" | |
| 25-431J | 53292 | .0005" | .050" | .500" | 0-50 |
| 25-631J | 53304 | .0005" | .050" | 1.000" | |
| 25-142J | 53242 | .001" | .020" | .050" | 0-10-0 |
| 25-242J | 53273 | .001" | .020" | .050" | 0-20 |
| 25-143J | 53244 | .001" | .030" | .075" | 0-15-0 |
| 25-243J | 53275 | .001" | .030" | .075" | 0-30 |
| 25-144J | 53246 | .001" | .040" | .100" | 0-20-0 |
| 25-244J | 53277 | .001" | .040" | .100" | 0-40 |
| 25-145J | 53248 | .001" | .050" | .125" | 0-25-0 |
| 25-245J | 53279 | .001" | .050" | .125" | 0-50 |
| 25-141J | 53240 | .001" | .100" | .250" | 0-50-0 |
| 25-241J | 53271 | .001" | .100" | .250" | 0-100 |
| 25-341/5J | 53285 | .001" | .100" | .500" | 0-50-0 |
| 25-441/5J | 53293 | .001" | .100" | .500" | 0-100 |
| 25-441/5J W/SLC* | 66864 | .001" | .100" | .500" | 0-100 |
| 25-341J | 53287 | .001" | .100" | 1.000" | 0-50-0 |
| 25-441J | 53295 | .001" | .100" | 1.000" | 0-50-0 |
| 25-441J W/SLC* | 66863 | .001" | .100" | 1.000" | 0-100 |

25 Dial Indicators with Jewel Bearings

| Cat. No. | EDP | Graduation | Range One Rev. | Total | Dial Reading |
|-----------|-------|------------|----------------|--------|--------------|
| 25-341/5P | 53286 | .001" | .100" | .500" | 0-50-0 |
| 25-441/5P | 53294 | .001" | .100" | .500" | 0-100 |
| 25-341P | 53288 | .001" | .100" | 1.000" | 0-50-0 |
| 25-441P | 53296 | .001" | .100" | 1.000" | 0-100 |

* Includes redemption card for Standard Letter of Certification.



DIAL INDICATORS

253 DIAL INDICATOR SETS

INCH AND MILLIMETER READING

These sets provide in one handy, compact kit three 25 Dial Indicators to handle most gaging jobs at a minimum cost. Sets are ideal for tool and die shops, machine shops and toolrooms having occasional work where a heavy investment in dial indicators would not be practical. The indicators are furnished with jewel bearings.



253 Dial Indicator Sets

| Cat. No. | EDP | Description |
|----------|-------|---|
| S253Z | 51218 | Set of 3 Inch Reading Dial Indicators: 25-111J, 25-131J and 25-441J |
| S253MZ | 56283 | Set of 3 Millimeter Reading Dial Indicators: 25-161J, 25-181J and 25-881J |

Sets furnished in attractive, protective case.

655 DIAL INDICATORS

AGD GROUP 3

RANGES UP TO 1" AND 25MM

These indicators have a shockless, hardened steel gear train and jewel bearings. They are furnished with a lug-on-center back. Antimagnetic and special non-shock mechanisms are options available for all models. For more information on these and other attachments, accessories and contact points, refer to the end of the AGD Dial Indicator listings. For dial styles, see previous pages.

If lift lever is desired, indicator must be ordered with case stem cap.

655 Dial Indicators

| Cat. No. | EDP | Graduation | Range One Rev. | Total | Dial Reading | Stem Dia. |
|------------|-------|------------|----------------|-------|--------------|---------------|
| 655-161J | 53533 | 0.002mm | 0.2mm | 0.5mm | 0-10-0 | .375" (9.5mm) |
| 655-161J-8 | 64659 | | | | | |
| 655-261J | 53603 | 0.002mm | 0.2mm | 0.5mm | 0-20 | .375" (9.5mm) |
| 655-261J-8 | 64660 | | | | | |
| 655-181J | 53535 | 0.01mm | 1.0mm | 2.5mm | 0-50-0 | .375" (9.5mm) |
| 655-181J-8 | 64661 | | | | | |
| 655-281J | 53605 | 0.01mm | 1.0mm | 2.5mm | 0-100 | .375" (9.5mm) |
| 655-281J-8 | 64868 | | | | | |
| 655-881J | 56229 | 0.01mm | 1.0mm | 25mm | 0-100 | .375" (9.5mm) |
| 655-881J-8 | 64869 | | | | | |

655 Dial Indicators

| Cat. No. | EDP | Graduation | Range One Rev. | Total | Dial Reading |
|------------|-------|------------|----------------|--------|--------------|
| 655-118J | 53507 | .0001" | .008" | .020" | 0-4-0 |
| 655-111J | 53505 | .0001" | .010" | .025" | 0-5-0 |
| 655-211J | 53537 | | | | 0-10 |
| 655-511J | 53615 | .0001" | .010" | .200" | 0-5-0 |
| 655-611J | 53617 | | | | 0-10 |
| 655-124J | 53509 | .00025" | .010" | .025" | 0-5-0 |
| 655-224J | 53539 | | | | 0-10 |
| 655-128J | 53511 | .00025" | .020" | .050" | 0-10-0 |
| 655-228J | 53541 | | | | 0-20 |
| 655-129J | 53513 | .00025" | .030" | .075" | 0-15-0 |
| 655-229J | 53543 | | | | 0-30 |
| 655-134J | 53517 | .0005" | .020" | .050" | 0-10-0 |
| 655-234J | 53587 | | | | 0-20 |
| 655-136J | 53519 | .0005" | .030" | .075" | 0-15-0 |
| 655-236J | 53589 | | | | 0-30 |
| 655-138J | 53521 | .0005" | .040" | .100" | 0-20-0 |
| 655-238J | 53591 | | | | 0-40 |
| 655-131J | 53515 | .0005" | .050" | .125" | 0-25-0 |
| 655-231J | 53585 | | | | 0-50 |
| 655-142J | 53525 | .001" | .020" | .050" | 0-10-0 |
| 655-242J | 53595 | | | | 0-20 |
| 655-143J | 53527 | .001" | .030" | .075" | 0-15-0 |
| 655-243J | 53597 | | | | 0-30 |
| 655-144J | 53529 | .001" | .040" | .100" | 0-20-0 |
| 655-244J | 53599 | | | | 0-40 |
| 655-145J | 53531 | .001" | .050" | .125" | 0-25-0 |
| 655-245J | 53601 | | | | 0-50 |
| 655-141J | 53523 | .001" | .100" | .250" | 0-50-0 |
| 655-241J | 53593 | | | | 0-100 |
| 655-341/5J | 53607 | .001" | .100" | .500" | 0-50-0 |
| 655-441/5J | 53611 | | | | 0-100 |
| 655-341J | 53609 | .001" | .100" | 1.000" | 0-50-0 |
| 655-441J | 53613 | | | | 0-100 |



655-111J



655-161J-8

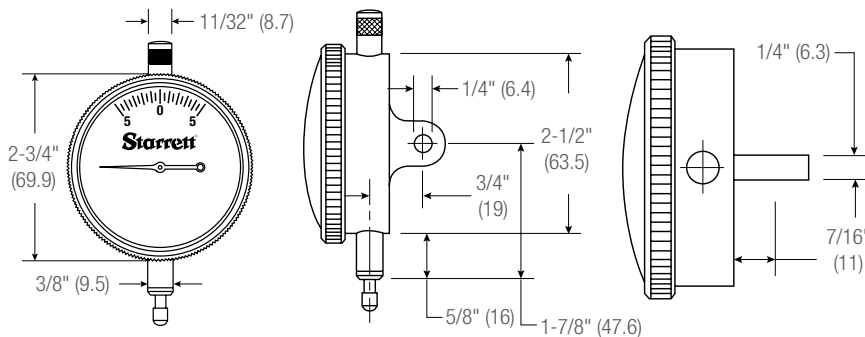

655-131J with top lift

655-341J with stem cap



DIAL INDICATORS

656 DIAL INDICATORS

AGD GROUP 4

RANGES UP TO 1" AND 25MM

These indicators have a shockless, hardened steel gear train and jewel bearings. They are furnished with a lug-on-center back. Antimagnetic mechanism is optional for all models. Special non-shock mechanism is available for all models except 656-109 and 656-209. For more information on these and other attachments, accessories and contact points, refer to the end of the AGD Dial Indicator listings. For dial styles, see previous pages.

If lift lever is desired, indicator must be ordered with case stem cap.



656-111J



656-161J-8

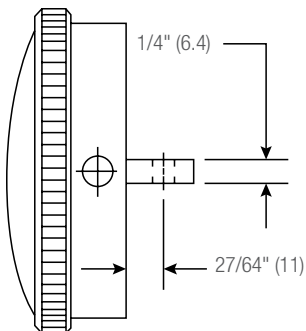
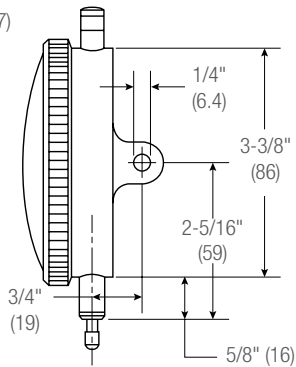
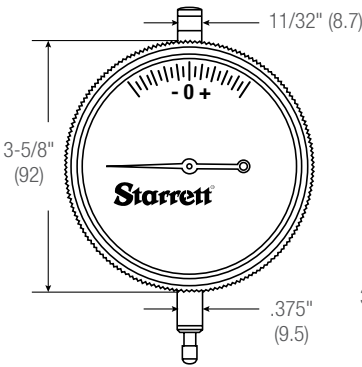

Free drafting template available for this size.
Write The L. S. Starrett Co. at:
121 Crescent Street
Athol, MA 01331.

| 656 Dial Indicators | | | | | | |
|---------------------|-------|------------|----------|-------|--------------|---------------|
| Cat. No. | EDP | Graduation | Range | | Dial Reading | Stem Dia. |
| | | | One Rev. | Total | | |
| 656-161J | 53690 | 0.002mm | 0.2mm | 0.5mm | 0-10-0 | .375" (9.5mm) |
| 656-161J-8 | 64870 | | | | | |
| 656-261J | 53779 | 0.002mm | 0.2mm | 0.5mm | 0-20 | .375" (9.5mm) |
| 656-261J-8 | 64871 | | | | | |
| 656-181J | 53692 | 0.01mm | 1.0mm | 2.5mm | 0-50-0 | .375" (9.5mm) |
| 656-181J-8 | 64872 | | | | | |
| 656-281J | 53781 | 0.01mm | 1.0mm | 2.5mm | 0-100 | .375" (9.5mm) |
| 656-281J-8 | 64873 | | | | | |
| 656-881J | 56234 | 0.01mm | 1.0mm | 25mm | 0-100 | .375" (9.5mm) |
| 656-881J-8 | 64874 | | | | | |

| 656 Dial Indicators | | | | | |
|---------------------|-------|------------|----------|--------|--------------|
| Cat. No. | EDP | Graduation | Range | | Dial Reading |
| | | | One Rev. | Total | |
| 656-109J | 53661 | .00005" | .006" | .015" | 0-3-0 |
| 656-209J | 53694 | | | | 0-6 |
| 656-118J | 53664 | .0001" | .008" | .020" | 0-4-0 |
| 656-111J | 53662 | | | | 0-5-0 |
| 656-211J | 53695 | .0001" | .010" | .025" | 0-10 |
| 656-511J | 53791 | | | | 0-5-0 |
| 656-611J | 53795 | .0001" | .010" | .200" | 0-10 |
| 656-517J | 53793 | | | | 0-10-0 |
| 656-617J | 53797 | .0001" | .020" | .400" | 0-20 |
| 656-124J | 53666 | | | | 0-5-0 |
| 656-224J | 53697 | .00025" | .010" | .025" | 0-10 |
| 656-128J | 53668 | | | | 0-10-0 |
| 656-228J | 53699 | .00025" | .020" | .050" | 0-20 |
| 656-129J | 53670 | | | | 0-15-0 |
| 656-229J | 53701 | .00025" | .030" | .075" | 0-30 |
| 656-134J | 53674 | | | | 0-10-0 |
| 656-234J | 53705 | .0005" | .020" | .050" | 0-20 |
| 656-136J | 53676 | | | | 0-15-0 |
| 656-236J | 53707 | .0005" | .030" | .075" | 0-30 |
| 656-138J | 53678 | | | | 0-20-0 |
| 656-238J | 53709 | .0005" | .040" | .100" | 0-40 |
| 656-131J | 53672 | | | | 0-25-0 |
| 656-231J | 53703 | .0005" | .050" | .125" | 0-50 |
| 656-142J | 53682 | | | | 0-10-0 |
| 656-242J | 53713 | .001" | .020" | .050" | 0-20 |
| 656-143J | 53684 | | | | 0-15-0 |
| 656-243J | 53715 | .001" | .030" | .075" | 0-30 |
| 656-144J | 53686 | | | | 0-20-0 |
| 656-244J | 53717 | .001" | .040" | .100" | 0-40 |
| 656-145J | 53688 | | | | 0-25-0 |
| 656-245J | 53719 | .001" | .050" | .125" | 0-50 |
| 656-141J | 53680 | | | | 0-50-0 |
| 656-241J | 53711 | .001" | .100" | .250" | 0-100 |
| 656-341/5J | 53783 | | | | 0-50-0 |
| 656-441/5J | 53787 | .001" | .100" | .500" | 0-100 |
| 656-341J | 53785 | | | | 0-50-0 |
| 656-441J | 53789 | .001" | .100" | 1.000" | 0-100 |

656-441J with top lift



656-129J stem cap required for use with lift lever
See page 170



DIAL INDICATORS

25, 655, 656 DIAL INDICATORS WITH LONG RANGE

2-5" RANGES

These indicators have a shockless, hardened steel gear train and are furnished with jewel bearings and lug-on-center backs unless otherwise ordered.

- Conforms to AGD specifications except for range
- Stem cap supplied as standard – top lift available when specified
- Furnished with continuous reading double dial with direct reading count hands

25, 655, 656 Dial Indicators with Long Range

| Cat. No. | EDP | Graduation | Range | Dial Reading | Revs. of Hand | AGD Group | Bezel Diameter |
|-----------|-------|------------|--------|--------------|---------------|-----------|----------------|
| 25-2041J | 53309 | | | | | 2 | 2-1/4" |
| 655-2041J | 53619 | .001" | 2.000" | 0-100 | 20 | 3 | 2-3/4" |
| 656-2041J | 53799 | | | | | 4 | 3-5/8" |
| 25-3041J | 53310 | | | | | 2 | 2-1/4" |
| 655-3041J | 53620 | .001" | 3.000" | 0-100 | 30 | 3 | 2-3/4" |
| 656-3041J | 53800 | | | | | 4 | 3-5/8" |
| 25-4041J | 53311 | | | | | 2 | 2-1/4" |
| 655-4041J | 53621 | .001" | 4.000" | 0-100 | 40 | 3 | 2-3/4" |
| 656-4041J | 53801 | | | | | 4 | 3-5/8" |
| 25-5041J | 53312 | | | | | 2 | 2-1/4" |
| 655-5041J | 53622 | .001" | 5.000" | 0-100 | 50 | 3 | 2-3/4" |
| 656-5041J | 53802 | | | | | 4 | 3-5/8" |

Not available with special non-shock mechanism. For other attachments, accessories and contact points, refer to the end of the AGD Dial Indicator listings.

Approximate Dimensions

| Cat. No. | A | B | C | D | E | F | G |
|-----------|--------|---------|----------|---------|---------|--------|--------|
| 25-2041J | 2-1/4" | 2-1/16" | 1-13/16" | 2-1/16" | 3-3/32" | 2-7/8" | 15/32" |
| 655-2041J | 2-3/4" | 2-1/2" | 1-5/8" | 2-1/16" | 3-3/32" | 2-7/8" | 7/16" |
| 656-2041J | 3-5/8" | 3-3/8" | 1-1/4" | 2-1/16" | 3-3/32" | 3" | 27/64" |
| 25-3041J | 2-1/4" | 2-1/16" | 2-13/16" | 3-1/16" | 4-9/16" | 3-7/8" | 15/32" |
| 655-3041J | 2-3/4" | 2-1/2" | 2-5/8" | 3-1/16" | 4-9/16" | 3-7/8" | 7/16" |
| 656-3041J | 3-5/8" | 3-3/8" | 2-1/4" | 3-1/16" | 4-9/16" | 4" | 27/64" |
| 25-4041J | 2-1/4" | 2-1/16" | 3-13/16" | 4-1/16" | 6" | 4-7/8" | 15/32" |
| 655-4041J | 2-3/4" | 2-1/2" | 3-5/8" | 4-1/16" | 6" | 4-7/8" | 7/16" |
| 656-4041J | 3-5/8" | 3-3/8" | 3-1/4" | 4-1/16" | 6" | 5" | 27/64" |
| 25-5041J | 2-1/4" | 2-1/16" | 4-13/16" | 5-1/16" | 7-1/4" | 5-7/8" | 15/32" |
| 655-5041J | 2-3/4" | 2-1/2" | 4-5/8" | 5-1/16" | 7-1/4" | 5-7/8" | 7/16" |
| 656-5041J | 3-5/8" | 3-3/8" | 4-1/4" | 5-1/16" | 7-1/4" | 6" | 27/64" |

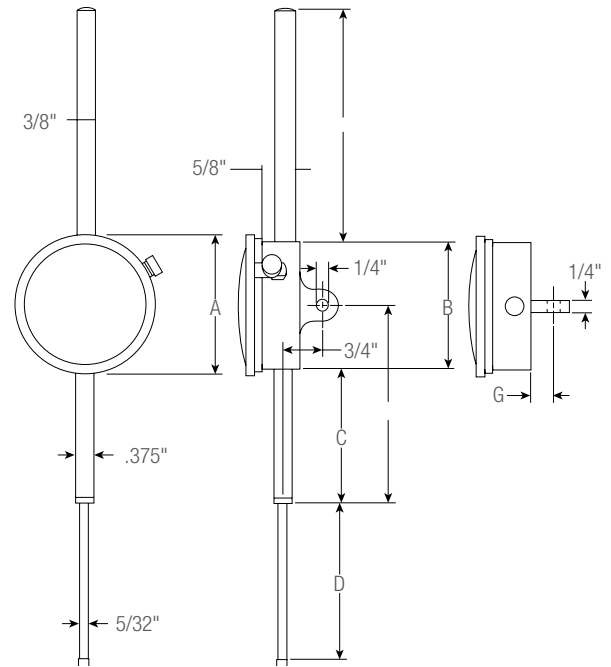

25-2041J



DIAL INDICATORS

25, 655 METRIC DIAL INDICATORS WITH LONG RANGE

50-125MM RANGES

These indicators have a shockless, hardened steel gear train and are furnished with jewel bearings and lug-on-center backs unless otherwise ordered.

- Conforms to AGD specifications except for range
- Furnished with continuous reading double dial
- Direct readout accomplished by (1) graduated top tube which indicates each 10mm of spindle travel, (2) revolution counter which indicates each 1mm full turn of the indicator hand, and (3) indicator hand which shows each 0.01mm of spindle movement

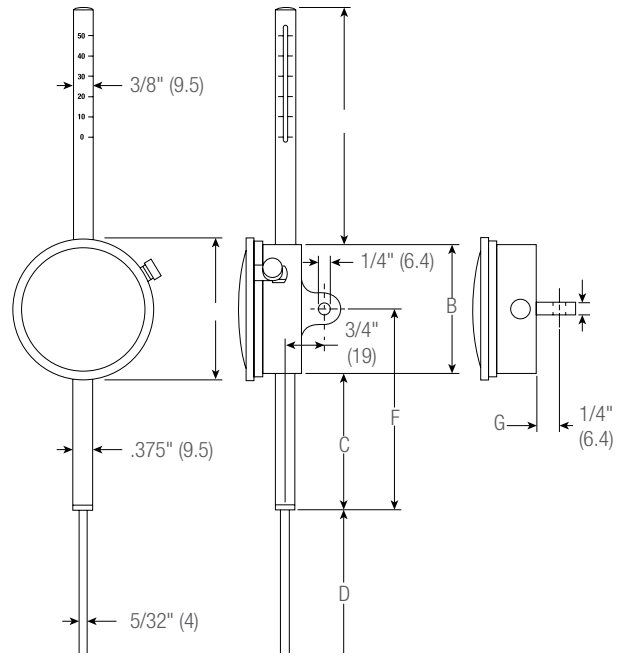

| 25, 655 Metric Dial Indicators with Long Range | | | | | | | |
|--|-------|------------|-----------|---------------|-------|--------------|---------------|
| Cat. No. | EDP | Graduation | AGD Group | Stem Diameter | Range | Dial Reading | Revs. of Hand |
| 25-2081J | 56225 | 0.01mm | 2 | .375" (9.5mm) | 50mm | 0-100 | 50 |
| 655-2081J | 56230 | 0.01mm | 3 | .375" (9.5mm) | 75mm | 0-100 | 75 |
| 25-3081J | 56226 | 0.01mm | 2 | .375" (9.5mm) | 100mm | 0-100 | 100 |
| 655-3081J | 56231 | 0.01mm | 3 | .375" (9.5mm) | 125mm | 0-100 | 125 |
| 25-4081J | 56227 | 0.01mm | 2 | .375" (9.5mm) | | | |
| 655-4081J | 56232 | 0.01mm | 3 | .375" (9.5mm) | | | |
| 25-5081J | 56228 | 0.01mm | 2 | .375" (9.5mm) | | | |
| 655-5081J | 56233 | 0.01mm | 3 | .375" (9.5mm) | | | |

Not available with special non-shock mechanism. For contact points, attachments and accessories, refer to the end of the AGD Dial Indicator listings.

| Approximate Dimensions Inch and Millimeter | | | | | | | |
|--|---------------|-----------------|------------------|-----------------|------------------|----------------|---------------|
| Cat. No. | A | B | C | D | E | F | G |
| 25-2081J | 2-1/4" (57mm) | 2-1/16" (52mm) | 1-13/16" (46mm) | 2-1/16" (52mm) | 3-3/32" (79mm) | 2-7/8" (73mm) | 15/32" (12mm) |
| 655-2081J | 2-3/4" (70mm) | 2-1/2" (63.5mm) | 1-5/8" (41mm) | 2-1/16" (52mm) | 3-3/32" (79mm) | 2-7/8" (73mm) | 7/16" (11mm) |
| 25-3081J | 2-1/4" (57mm) | 2-1/16" (52mm) | 2-13/16" (71mm) | 3-1/16" (78mm) | 4-9/16" (116mm) | 3-7/8" (98mm) | 15/32" (12mm) |
| 655-3081J | 2-3/4" (70mm) | 2-1/2" (63.5mm) | 2-5/8" (67mm) | 3-1/16" (78mm) | 4-9/16" (116mm) | 3-7/8" (98mm) | 7/16" (11mm) |
| 25-4081J | 2-1/4" (57mm) | 2-1/16" (52mm) | 3-13/16" (81mm) | 4-1/16" (103mm) | 5-61/64" (151mm) | 4-7/8" (124mm) | 15/32" (12mm) |
| 655-4081J | 2-3/4" (70mm) | 2-1/2" (63.5mm) | 3-5/8" (92mm) | 4-1/16" (103mm) | 5-61/64" (151mm) | 4-7/8" (124mm) | 7/16" (11mm) |
| 25-5081J | 2-1/4" (57mm) | 2-1/16" (52mm) | 4-13/16" (122mm) | 5-1/16" (129mm) | 7-1/4" (184mm) | 5-7/8" (149mm) | 15/32" (12mm) |
| 655-5081J | 2-3/4" (70mm) | 2-1/2" (63.5mm) | 4-5/8" (117.5mm) | 5-1/16" (129mm) | 7-1/4" (184mm) | 5-7/8" (149mm) | 7/16" (11mm) |



DIAL INDICATORS

656 DIAL INDICATORS WITH EXTRA LONG RANGE

AGD GROUP 4

6-12" RANGES

These indicators have a shockless, hardened steel gear train and are furnished with jewel bearings and lug-on-center backs unless otherwise ordered.

- Use anywhere a long reach is needed – positioning of stops, measuring travel of slides and cam throws, and use in deep slots or holes
- Conforms to AGD specifications except for range, stems and contact point
- Top stem graduated in 1" increments, called out by red colored pointer
- Furnished with continuous reading double dial with direct reading count hand

656 Dial Indicators with Extra-Long Range

| Cat. No. | EDP | Graduation | AGD Group | Dial Diameter | Range | Dial Reading | Revs. of Hand |
|------------|-------|------------|-----------|---------------|---------|--------------|---------------|
| 656-6041J | 53803 | | | | 6.000" | | 60 |
| 656-7041J | 53804 | | | | 7.000" | | 70 |
| 656-8041J | 53805 | | | | 8.000" | | 80 |
| 656-9041J | 53806 | .001" | 4 | 3-5/8" | 9.000" | 0-100 | 90 |
| 656-10041J | 53807 | | | | 10.000" | | 100 |
| 656-11041J | 53808 | | | | 11.000" | | 110 |
| 656-12041J | 53809 | | | | 12.000" | | 120 |

Not available with special non-shock mechanism. For contact points, attachments and accessories, refer to the end of the AGD Dial Indicator Section

Dimensions

| Cat. No. | A | B | C | D |
|------------|---------|----------|---------|-----------|
| 656-6041J | 5-1/4" | 6-1/16" | 8-3/4" | 6-15/16" |
| 656-7041J | 6-1/4" | 7-1/16" | 9-3/4" | 7-15/16" |
| 656-8041J | 7-1/4" | 8-1/16" | 10-3/4" | 8-15/16" |
| 656-9041J | 8-1/4" | 9-1/16" | 11-3/4" | 9-15/16" |
| 656-10041J | 9-1/4" | 10-1/16" | 12-3/4" | 10-15/16" |
| 656-11041J | 10-1/4" | 11-1/16" | 13-3/4" | 11-15/16" |
| 656-12041J | 11-1/4" | 12-1/16" | 14-3/4" | 12-15/16" |

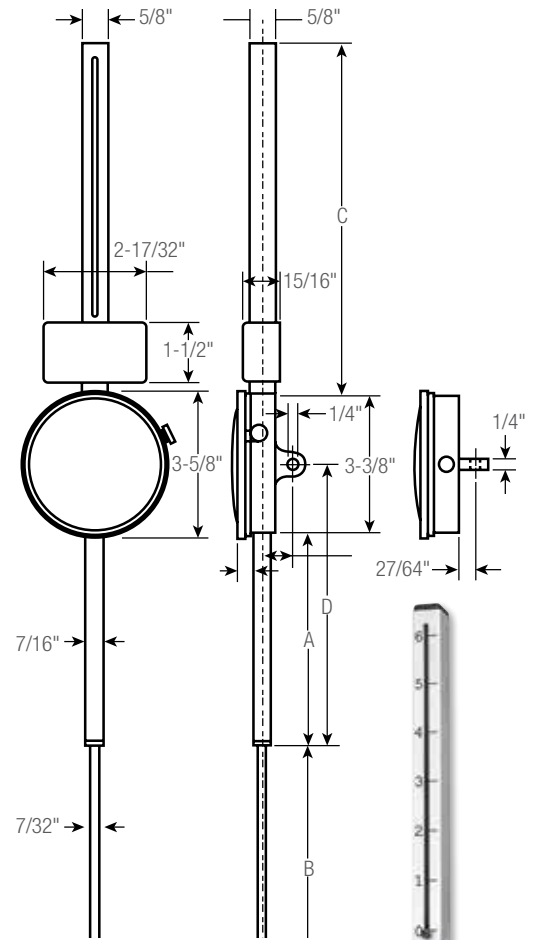

656-6041J



INDICATOR BACKS

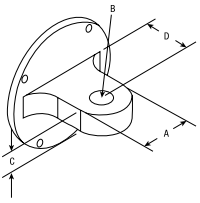

Lug-On-Center

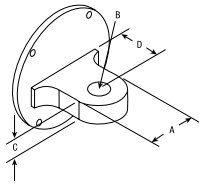

Lug-Off-Center

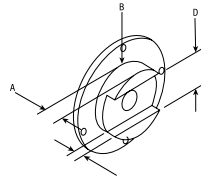

Adjustable Bracket

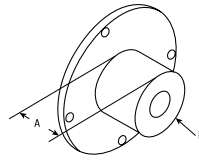

Screw-Type Lug

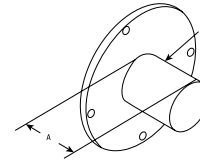

Post-Type Lug

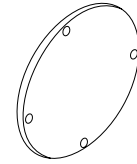

Flat

AGD Dial Indicator Backs

| Part No. | EDP | Dimensions | | | | | | | | Type | Fits Starrett Indicator Models | |
|-----------|-------|------------|------|-------|------|------|-----|------|------|------|--------------------------------------|----------|
| | | A in | mm | B in | mm | C in | mm | D in | mm | | | |
| PT06836-1 | 70856 | | | | | | | | | | | 81 |
| PT07206-1 | 70960 | | | | | | | | | | | 25, 2600 |
| PT06966-1 | 70888 | 5/8 | 16 | 1/4 | 6.3 | 1/4 | 6.3 | | | | Lug-On-Center* | 655 |
| PT07317-1 | 70980 | | | | | | | | | | | 656 |
| PT06836 | 70855 | | | | | | | | | | | 81 |
| PT06608-1 | 70770 | | | | | | | | | | | 25, 2600 |
| PT06966A | 71996 | 5/8 | 16 | 1/4 | 6.3 | 1/4 | 6.3 | | | | Lug-Off-Center** | 655 |
| PT07317A | 71997 | | | | | | | | | | | 656 |
| PT06836M | 70859 | 1/4 | 6.3 | 7/8 | 22 | 1/8 | 3 | 1/2 | 12.7 | | Adjustable Bracket (#1/4-20 Thread)† | 81 |
| PT06608M | 70776 | | | | | | | | | | | 25, 2600 |
| PT06878M | 70874 | 1/4 | 6.3 | 1-1/4 | 32 | 1/8 | 3 | 1/2 | 12.7 | | Adjustable Bracket (#1/4-20 Thread)† | 655 |
| PT06903M | 70882 | | | | | | | | | | | 656 |
| PT24074 | 72482 | | | | | | | | | | | 81 |
| PT24076 | 72483 | | | | | | | | | | | 25, 2600 |
| PT24078 | 72484 | 1/2 | 12.7 | 5/8 | 16 | | | | | | Screw-Type Lug (#1/4-20 Thread)† | 655 |
| PT24080 | 72485 | | | | | | | | | | | 656 |
| PT06836S | 72223 | | | | | | | | | | | 81 |
| PT06608E | 70772 | | | | | | | | | | | 25, 2600 |
| PT06878E | 72224 | 1/2 | 12.7 | 5/8 | 16 | | | | | | Screw-Type Lug (#3/8-24 Thread)† | 655 |
| PT06903E | 72225 | | | | | | | | | | | 656 |
| PT24073 | 72486 | | | | | | | | | | | 81 |
| PT24075 | 72487 | | | | | | | | | | | 25, 2600 |
| PT24077 | 72488 | 1/2 | 12.7 | 5/8 | 16 | | | | | | Screw-Type Lug (#1/4-28 Thread)† | 655 |
| PT24079 | 72489 | | | | | | | | | | | 656 |
| PT06836F | 70857 | | | | | | | | | | | 81 |
| PT06608F | 70773 | | | | | | | | | | | 25, 2600 |
| PT06878F | 71992 | 1-1/4 | 32 | 1/2 | 12.7 | | | | | | Post-Type Lug† | 655 |
| PT06903F | 71994 | | | | | | | | | | | 656 |
| PT06836J | 70858 | | | | | | | | | | | 81 |
| PT06608J | 70774 | | | | | | | | | | | 25, 2600 |
| PT06878J | 70873 | | | | | | | | | | Flat** | 655 |
| PT06903J | 71995 | | | | | | | | | | | 656 |
| PT24921 | 67295 | | | | | | | | | | | 81 |
| PT26160 | 67405 | | | | | | | | | | Flat (Plastic) | 25, 2600 |

* Regularly furnished on all listed indicators at no extra charge.

** When specified, available on all listed indicators at no extra charge.

† When specified, available at extra charge on all listed indicators. Backs for special requirements are also available; priced on application.



DIAL INDICATORS

647 DIAL COMPARATOR INDICATORS

The 647 Dial Comparator Indicators offer a high degree of security and precision. They are based on a solid and well thought-out construction taking into account the latest technology. They are manufactured by the most up-to-date methods.

647 and 647M Dial Comparator Indicators

| Cat. No. | EDP | Range | Graduation | Dial Reading |
|----------|-------|-------|------------|--------------|
| 647 | 00001 | .004" | .00005" | 20-0-20 |
| 647M | 00002 | 0.1mm | 0.001mm | 50-0-50 |

647 and 647M Dial Comparator Indicator Accessories

| Part No. | EDP | Description |
|----------|-------|--------------------|
| PT15052 | 00537 | Lug-on-center back |
| PT15053 | 00538 | Lift cable |

FEATURES AND SPECIFICATIONS

- Effective non-shock mechanism
- Pinions and shafts of the movement are jeweled
- After removal of the safety cap and adjustment screw on top of the case allows simple and safe zero setting of the instrument over the total measuring range
- A safety cap prevents unintentional turning of the fine adjustment screws
- Stem and spindle are made of hardened stainless steel
- The measuring spindles are very sensitive on account of their accurate guides
- Additional overtravel assists with the insertion of work pieces into the measuring device
- The clear scale is shadow free
- The red tolerance markers are easy to recognize and to set
- Furnish with flat back



647



647M



INDICATOR BACKS

SPECIAL INDICATOR BACKS

674 BACKS WITH ADJUSTABLE MOUNTING BRACKET

For use with gages and gaging fixtures where an adjustable indicator mounting is required. A dovetail with rack and pinion adjustment provides 1-1/8" (28mm) indicator travel. A 1/8" hex wrench is used to adjust and lock the indicator in final position. The bracket has two counter-bored mounting holes (for 1/4" socket head screws), and the back has four screw holes so the indicator back can be rotated.

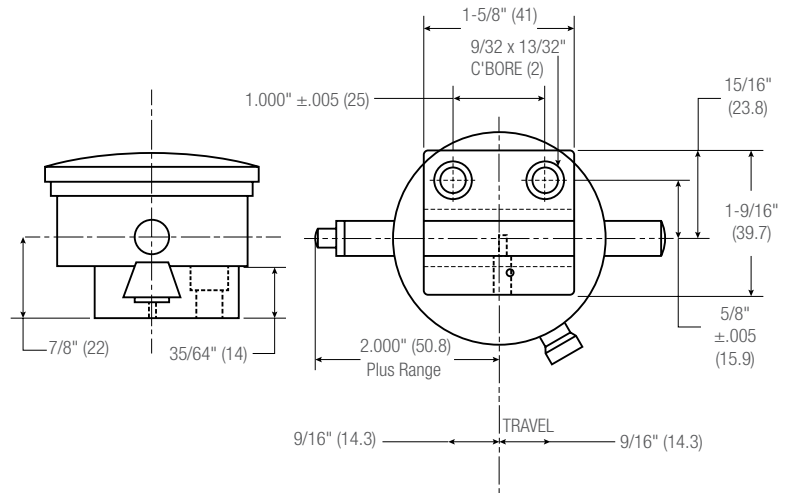

674 Backs with Adjustable Mounting Bracket

| Cat. No. | EDP | Fits Starrett Models |
|----------|-------|----------------------|
| 674-1 | 66374 | 81 |
| 674-2 | 52892 | 25, 2600, 2900 |
| 674-3 | 52893 | 655 |
| 674-4 | 52894 | 656 |

674-2

676 MAGNETIC BACKS

These magnetic backs provide a quick and easy means of attaching any Starrett AGD indicator to flat, ferrous metal surfaces. A real time-saver for machine, jig and fixture set up. Requires no clamps, rods or snugs. A special 5/16"-24 threaded stud back is provided to replace the standard lug back. The powerful, permanent magnet is then attached to the threaded stud. Anti-magnetic indicators are not required.

676 Magnetic Backs

| Cat. No. | EDP | Fits Starrett Models |
|----------|-------|----------------------|
| 676-1 | 56647 | 81 |
| 676-2 | 56648 | 25, 2600, 2900 |
| 676-3 | 56649 | 655 |
| 676-4 | 56650 | 656 |



676-2

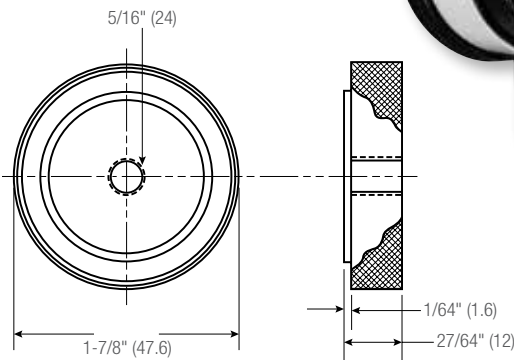

672 UNIVERSAL BACKS

Featuring a universal ball joint attached to the end of a gooseneck shank, these attachments make it possible to position an AGD indicator at any desired setting. The indicator can be rotated 360° and angularly up to 90° and locked in the desired position by tightening a single knurled nut. Straight shank is 3/8" (9.5mm) in diameter.

672 Universal Backs

| Cat. No. | EDP | Fits Starrett Models |
|----------|-------|----------------------|
| 672-2 | 52887 | 25, 2600, 2900 |
| 672-3 | 52888 | 655 |
| 672-4 | 52889 | 656 |



672-2

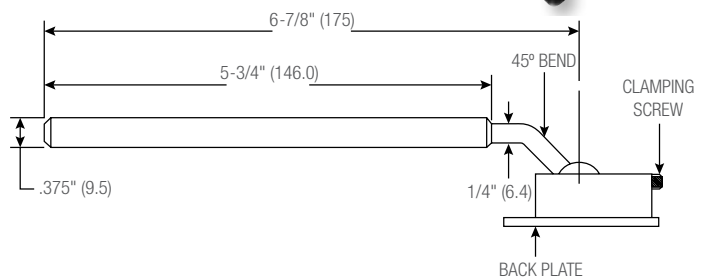

INDICATOR ACCESSORIES

AGD INDICATOR ATTACHMENTS AND ACCESSORIES

670 INDICATOR HOLE ATTACHMENT

These hole attachments make it possible to measure the inside of holes and other surfaces that cannot be reached with the regular indicator spindle. Both attachments have a .375" (9.5mm) diameter hole to fit all indicators made to AGD standards and can be securely clamped to the indicator stem. The ball end on the swivel arm which contacts the work is 1/8" (3mm) in diameter.

| 670 Indicator Hole Attachment | | | | | |
|-------------------------------|-------|-----------------|------|---------------------|----|
| Cat. No. | EDP | Range (Approx.) | | For Hole Depths to: | |
| | | in | mm | in | mm |
| 670A | 52884 | 3/8 | 9.5 | 13/16 | 20 |
| 670B | 52724 | 9/16 | 14.3 | 1-11/16 | 42 |



671 UNIVERSAL ATTACHMENT

This Universal Attachment is for use with indicators having standard AGD .375" (9.5mm) stem diameters. It clamps on the indicator stem and its movement is transmitted through the contact point to the indicator. Furnished with two interchangeable arms, one straight for measuring internal surfaces and one angular for measuring at right angles to the indicator spindle.

| 671 Universal Attachment | | | | |
|--------------------------|-------|-----------------|----|--|
| Cat. No. | EDP | Range (Approx.) | | |
| | | in | mm | |
| 671 | 52886 | 1/8 | 3 | |

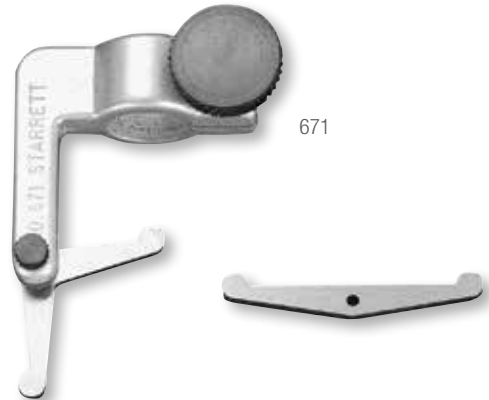

SPECIAL NON-SHOCK MECHANISM

Starrett dial indicators have hardened, stainless steel gears, pinions and racks for maximum resistance to shock. Where the rack is subject to repeated, severe and/or excessive mechanical shocks, many Starrett AGD dial indicators may be ordered with a special non-shock mechanism. Based on a positive-loaded, split gear assembly, this simple device protects indicator accuracy, prolongs life, and reduces service costs.

When ordering, specify "N/S" after the dial indicator catalog number.

The following indicators are not available with non-shock mechanism: 25-109, 25-209, 2600 and 2700 Indicators; 656-109, 656-209 and all other indicators with 2" (50mm) range and above.



25-111JNS with Special Non-Shock Mechanism



INDICATOR ACCESSORIES

AGD INDICATOR CONTACT POINTS AND ACCESSORIES

Any of the contact points listed here can also be used with the 650 and 651 Indicators and with the 196 Indicators by using the 196R Adapter.

EXTRA-LENGTH REGULAR-STYLE CONTACT POINTS WITH ROUND OR FLAT ENDS

1/4-4"/6-100MM

All Starrett AGD indicators are regularly furnished with 1/4" (6.4mm) length interchangeable contact points. Available in standard lengths to 4" (100mm). Diameter is 13/64" (5mm), with a #4-48 screw thread. Made from high grade steel, hardened and ground. Other lengths are also available priced on application. Available with round or flat ends as listed.

REGULAR-STYLE CARBIDE CONTACT POINTS WITH ROUND OR FLAT END

Two round points are available in standard lengths. 1/4" (6.3mm), PT08399-X (EDP 66053) – or – 1/2" (13mm), PT06677-X (EDP 66054). One flat point is available in standard length; 1/4" (6.3mm), PT10453-X (EDP 66068). Interchangeable points have a #4-48 screw thread. Longer lengths can be easily obtained by adding contact point extensions (see next page). Other sizes also available by request.

| Extra-Length Contact Points, Regular Style | | | | | |
|--|-------|-------------------|-------|-----------|-----|
| Rounded End Part No. | EDP | Flat End Part No. | EDP | Length in | mm |
| PT07215 | 70965 | | | | |
| PT01761 | 75263 | PT10453 | 72048 | 1/4 | 6.4 |
| PT06677 | 70823 | PT09560 | 71260 | 1/2 | 13 |
| PT06677A | 70824 | PT09560A | 71261 | 3/4 | 19 |
| PT06677B | 70825 | PT09560B | 71262 | 1 | 25 |
| PT06677C | 70826 | PT09560C | 71263 | 1-1/4 | 32 |
| PT06677D | 70827 | PT09560D | 71264 | 1-1/2 | 38 |
| PT06677E | 70828 | PT09560E | 71265 | 1-3/4 | 44 |
| PT06677F | 70829 | PT09560F | 71266 | 2 | 50 |
| PT06677G | 70830 | PT09560G | 71267 | 2-1/4 | 57 |
| PT06677H | 70831 | PT09560H | 71268 | 2-1/2 | 63 |
| PT06677J | 70832 | PT09560J | 71269 | 2-3/4 | 70 |
| PT06677K | 70833 | PT09560K | 71270 | 3 | 75 |
| PT10459 | 71327 | | | 4 | 100 |

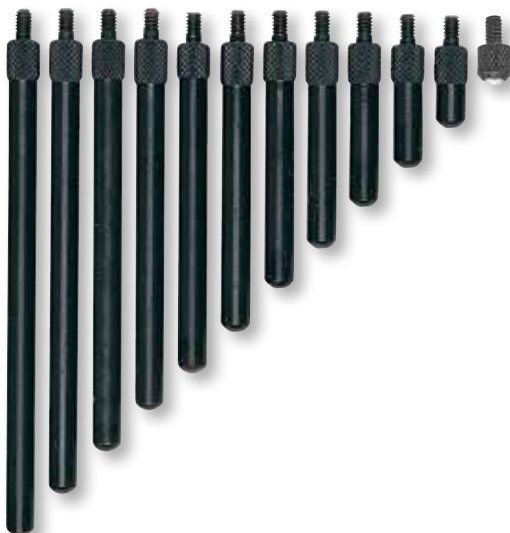

28 SHOCK ABSORBING ANVIL

Anvil replaces the regular contact point on any AGD indicator, protecting its movement against mechanical shock. Any sudden impact telescopes the anvil into the body of the unit against an internal spring. Acts as a solid contact point when the indicator is used normally. Furnished with #4-48 AGD standard screw thread.

| Shock Absorbing Anvil | |
|-----------------------|-------|
| Cat. No. | EDP |
| 28 | 50199 |



FLAT-END STEEL POINTS

The flat-end contact points have hardened steel contact surfaces, ground flat and lapped. They are furnished with a #4-48 screw thread for use on any AGD Indicator.

| Flat-End Steel Points | | | | |
|-----------------------|-------|----------|------|-----------|
| Part No. | EDP | Diameter | | Style No. |
| | | in | mm | |
| PT06632-17 | 70804 | 1/4 | 6.4 | 17 |
| PT06632-18 | 70805 | 3/8 | 9.5 | 18 |
| PT06632-19 | 70806 | 1/2 | 12.7 | 19 |
| PT06632-20 | 70808 | 3/4 | 19 | 20 |
| PT06632-21 | 70807 | 1 | 25 | 21 |

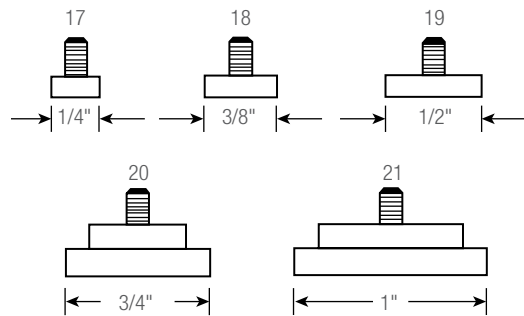

INDICATOR ACCESSORIES

AGD INDICATOR SPECIAL CONTACT POINTS AND ACCESSORIES

SPECIAL FORM CONTACT POINTS

Starrett Special Contact Points are furnished in fourteen shapes. Knurled diameter is approximately 13/64" (5mm). All have #4-48 screw thread and can be used on any AGD indicator. Other special shapes are available on special order.

Carbide, sapphire, diamond or teflon-coated contact points are also available by request.

25W ROLLER CONTACT POINT

This contact has a small, hardened roller 3/8" (9.5mm) in diameter for continuous gaging of moving material where the material movement is at a slow speed. Contact has #4-48 screw thread and substitutes for the regular contact point provided on Starrett and other AGD indicators. Furnished with a knurled check nut for positioning the contact on the indicator spindle. See drawing (right).

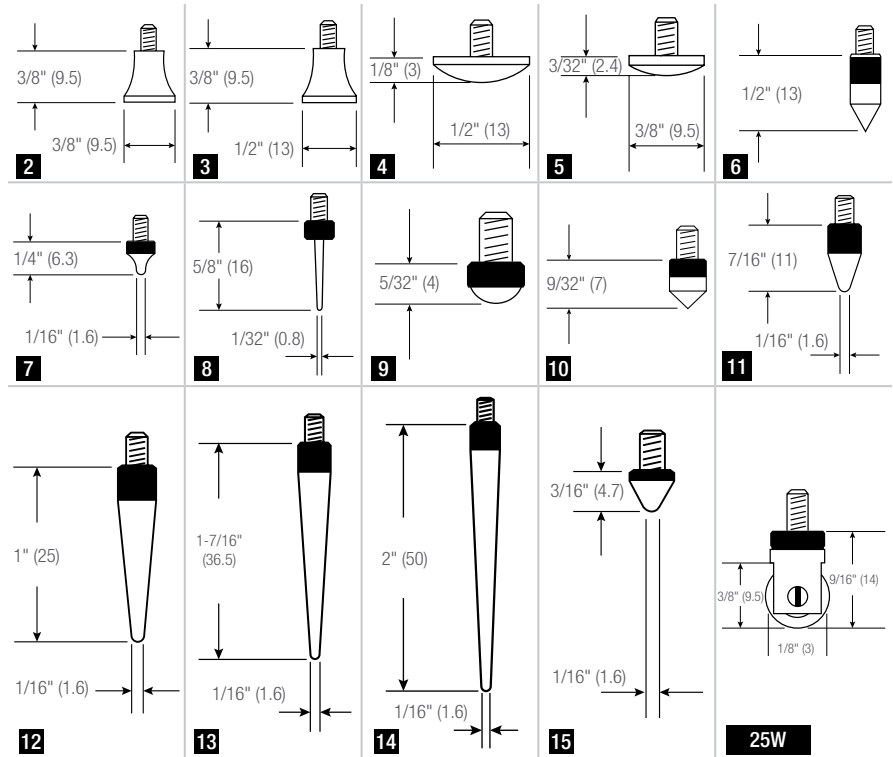

AGD CONTACT ADAPTERS

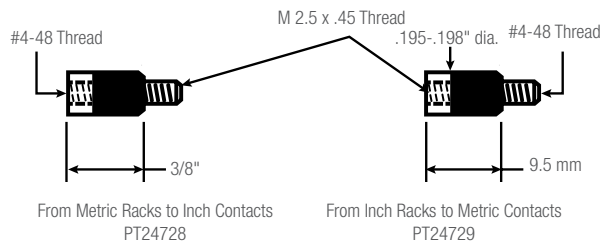

From Metric Racks to Inch Contacts
PT24728

From Inch Racks to Metric Contacts
PT24729

AGD CONTACT POINT EXTENSIONS

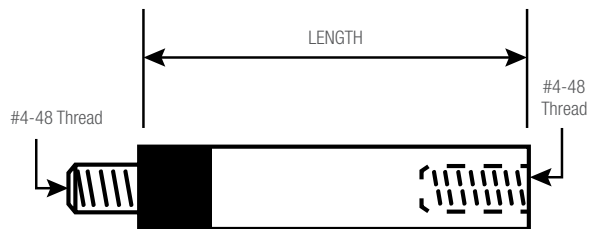

AGD Contact Point Extensions

| Part No. | EDP | Length |
|-------------|-------|--------|
| PT21697-1/2 | 64632 | 1/2" |
| PT21697-1 | 64633 | 1" |
| PT21697-2 | 64634 | 2" |
| PT21697-3 | 64635 | 3" |
| PT21697-4 | 64636 | 4" |

25R CONTACT POINT SET

14 points with #4-48 screw thread to fit AGD indicators: a regular 1/4" (6.3mm) long point; 9 special form points; a 28 Shock Absorbing Anvil; and 3 extra long points 1/2", 3/4" and 1" (13, 19, 25mm) long. High grade steel, hardened and ground. All points are mounted on a convenient aluminum ring for safe keeping and easy selection.

Contact Points

| Style No. | Part No. | EDP |
|-----------|------------|-------|
| 2 | PT06632-2 | 70790 |
| 3 | PT06632-3 | 70791 |
| 4 | PT06632-4 | 70792 |
| 5 | PT06632-5 | 70793 |
| 6 | PT06632-6 | 70794 |
| 7 | PT06632-7 | 70795 |
| 8 | PT06632-8 | 70796 |
| 9 | PT06632-9 | 70797 |
| 10 | PT06632-10 | 70798 |
| 11 | PT06632-11 | 70799 |
| 12 | PT06632-12 | 70800 |
| 13 | PT06632-13 | 70801 |
| 14 | PT06632-14 | 70802 |
| 15 | PT06632-15 | 70803 |
| | 25W | 53916 |
| | 25R | 50153 |
| | PT24728 | 64963 |
| | PT24729 | 64964 |

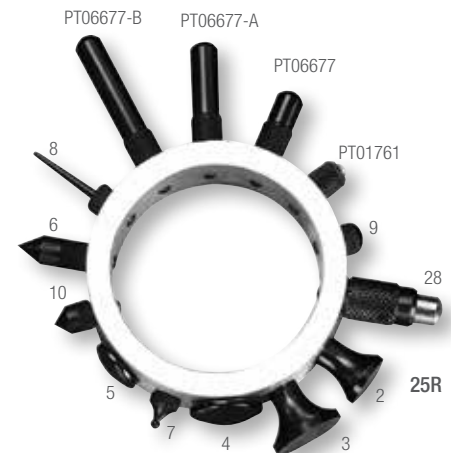

INDICATOR ACCESSORIES

AGD INDICATOR ACCESSORIES

25SC SPLIT COLLETS

ENGLISH AND METRIC THREADS

For mounting AGD Indicators with 3/8" (9.5 mm) or 8 mm stems in gaging and work location fixtures, these collets simplify fixture mounting. Screw the collet into the fixture or into our 648 Depth Gage Base, insert the indicator into the collet and tighten it in place with the hexagonal nut. Internal collet fingers grip the stem with equal pressure to eliminate spindle binding. Made of steel with black finish. Overall length of collet and threads is 1".



| 25SC Split Collets English Thread | | | | |
|-----------------------------------|-------|-------------|---------------|---|
| Cat. No. | EDP | Thread Size | Thread Length | Hole for Indicator Stem |
| 25SC14 | 50155 | 3/8-24NF | 9/32" (7mm) | .375" (9.5mm) Diameter to 1/2" (12.7mm) depth; 1/4" (6.3mm) Diameter through hole |
| 25SC38 | 50156 | 1/2-20NF | | .375" (9.5mm) Diameter through hole |
| 25SC38B | 55995 | 1/2-32UN | | .375" (9.5mm) Diameter through hole |
| 25SC Split Collets Metric Thread | | | | |
| Cat. No. | EDP | Thread Size | Thread Length | Hole for Indicator Stem |
| 25SC8M | 64885 | M12 x 1.75 | 7mm | 8mm Diameter through hole |

SPLIT BUSHINGS

Split bushings fit over the indicator stem to increase the overall diameter for mounting in fixtures.

| Split Bushings for 80 Miniature Dial Indicators | | | | |
|---|-------|--------|----------|---------|
| Cat. No. | EDP | Length | Diameter | |
| | | | Inside | Outside |
| 80SB | 56008 | 1/2" | .219" | .375" |
| Split Bushings for AGD English Indicators | | | | |
| Cat. No. | EDP | Length | Diameter | |
| | | | Inside | Outside |
| 25SB | 50154 | 1/2" | .375" | .500" |
| Split Bushings for AGD Metric Indicators | | | | |
| Cat. No. | EDP | Length | Diameter | |
| | | | Inside | Outside |
| 25MSB | 56007 | 12.7mm | 8mm | 9.5mm |

648 DEPTH GAGE BASES WITH STEM COLLET

Depth gage base with 25SC38 Stem Collet to fit 3/8" (9.5mm) stem dia. (as per AGD). Split bushings for adapting stem diameter are available but not included.

| 648 Depth Gage Bases with Stem Collet | | | |
|---------------------------------------|-------|-----------|-----|
| Cat. No. | EDP | Base Size | |
| | | in | mm |
| 648-4 | 65850 | 4 | 100 |
| 648-6 | 65851 | 6 | 150 |
| 648-8 | 65852 | 8 | 200 |

LONG STEM DIAL INDICATORS

Starrett 81, 25, 2600, 655 and 656 Indicators through the 1" (25mm) range can be furnished with long stems up to 12" (300mm). These are especially useful for gaging in deep holes or where obstructions prevent the use of regular indicators. Specify stem length from outside case diameter when ordering.

Long stems not available on 80 Miniature Dial Indicators.



THREADED STEMS

Threaded stems on Starrett indicators with a .375" (9.5mm diameter stem up to 1" (25mm) range (except long stem models) are available at additional cost. A threaded stem is often desirable for attaching the indicator to machine tools or fixtures. A 3/8-24 thread is furnished unless otherwise specified.

25LC RANGE LIMIT CAP

The Range Limit Cap replaces the stem cap furnished on most 81, 25, 2600, 655 and 656 AGD Indicators, preventing the possible error of a complete revolution. It can be adjusted to limit an indicator's measuring range any amount up to 3/8" (9.5mm).

| 25LC Range Limit Cap | |
|----------------------|-------|
| Part No. | EDP |
| 25LC | 50152 |



Split Bushing Attachment



Threaded Stem Attachment



Stem Collet



Range Limit Cap



INDICATOR ACCESSORIES

AGD INDICATOR ACCESSORIES

TOP LIFT

A knurled grip allows the spindle to be manually lifted and returned by spring action to contact the work. Furnished in place of the stem cap on .500", 1.000", 10mm and 25mm range indicators. No extra charge on AGD Indicators up to 1" (25mm) range; over 1" (25mm) range, priced on request. To order, specify "with Top Lift" after the indicator catalog number.

NOTE: Will not fit on 2700 Indicators.

RUBBER DUST GUARD

Protects the rack of AGD Indicators from foreign matter under adverse gaging conditions. Made in lengths to fit 81, 25, 2600, 655 and 656 Indicators up to 1" (25mm) range.

| Rubber Dust Guard | | |
|-------------------|-------|---|
| Part No. | EDP | Indicator Range |
| PT09545 | 71256 | .400", .500", 1.000" (10mm, 12.7mm, 25mm) |
| PT09763 | 71289 | Ranges under .400" (10mm) |

AGD DIAL INDICATOR TOLERANCE HANDS

Starrett dial indicators may be ordered with crystal-mounted or bezel-mounted tolerance hands for visually checking limits of a given dimension.

Crystal-mounted hands, both colored red, are positioned under the crystal and are individually adjustable through 360° by turning concentric knurled knobs on the outside of the crystal. Available for all 81, 25, 655 and 656 AGD Dial Indicators.

Bezel-mounted hands, both colored red, rotate inside the bezel. They are mounted outside the crystal and are independently adjustable through 360°. Available for 81 and 25 AGD Indicators only.

Snap-on bezel-mounted hands, two hands colored red, are easily mounted on the outside of the bezel and are adjustable through 360°. Available for 25 AGD Indicators only. Order PT99513 (EDP 66038).

MAXIMUM HAND

This red-colored hand records the maximum position reached by the indicator hand within a single revolution. Mounted under the crystal, it has a small nib at its point. The indicator hand contacts the nib, advancing the maximum hand which remains in position when the indicator hand returns to its at-rest position. To reset the maximum hand, turn the knurled knob mounted outside the crystal.

To order Tolerance or Maximum Hands, specify the indicator catalog number followed by the type of hand desired.

LEVER CONTROL

Handy attachment mounts in place of stem cap and is interchangeable on most Starrett 81, 25, 2600, 655 and 656 AGD Indicators up to 1" or 25mm range. Pressing down lever lifts spindle; releasing it lets spindle contact the work. Easy to install in the left or right hand position using a screwdriver and an open end wrench. If ordered on a new indicator, specify left or right hand position. (Furnished at left unless otherwise ordered.)

NOTE: Fits only indicators with a case stem cap.

| Lever Control | |
|---------------|-------|
| Part No. | EDP |
| PT99356 | 72088 |



Top Lift

Dust Guard



Indicators with snap-on bezel-mounted hands (left), crystal-mounted hands (above), and bezel-mounted hands (right).



Maximum Hand in at-rest position with indicator hand (left), and in recording position (right).



INDICATOR TESTERS

716, 716M INDICATOR TESTERS

0-1"/0-25MM

With direct reading capability to .0001" or 0.002mm, these gages provide a rapid means for calibrating both AGD and dial test indicators for linearity and repeatability through ranges up to 1" or 25mm. This tester design is unlike others because it can be swung to any position between vertical and horizontal by loosening a large hand knob which fastens the gage assembly to the base.

In addition, the micrometer head can be turned on its axis and its scale positioned to suit the operator's convenience by loosening a single set screw. Tensioned locking screws prevent tipping of both the gage assembly and the indicator holding clamp during set-up and adjustment.

The micrometer head is our 469 super-precision head with reverse reading capability. When testing a 2700 or 2900 Electronic Indicator, a .000050" graduated head is advisable, available on special order.

An indicator mounting attachment holds dovetail mount indicators, AGD indicators with 3/8" (9.5mm) stems and indicators with a holder that has a 3/16" (4.7mm) shank. Unit also has a fine adjustment to zero the indicator.



716MX

| 716 Indicator Tester (0-1" Range) | | | |
|---|-------|------------------------------------|---|
| Cat. No. | EDP | Micrometer Head Graduation* | Description |
| 716X | 67228 | .0001" | Tester with carbide faced spindle, indicator mounting and offset attachment |
| 716M Indicator Tester (0-25mm Range) | | | |
| Cat. No. | EDP | Micrometer Head Graduation* | Description |
| 716MX | 67229 | 0.002mm | Tester with carbide faced spindle, indicator mounting and offset attachment |
| Accessory for 716, 716M Indicator Testers | | | |
| Cat. No. | EDP | Description | |
| PT26009 | 65102 | Indicator mounting attachment only | |

*Available on special order with resolution to .000050" or 0.001mm.



Dial test indicator held in place by an offset attachment



Checking AGD dial indicator



NEW!

INDICATORS AND GAGES

ELECTRONIC INDICATORS

2900 ELECTRONIC INDICATORS

RANGES FROM .5" (12MM) TO 2" (50MM)
AGD GROUP 2

The 2900 Electronic Indicators are available in a choice of configurations to meet a range of requirements. Innovative True Absolute Sensor Technology minimizes the chance of data loss for exceptional reliability. Built with IP67 protection and renowned Starrett quality, they maintain their reliability in hostile shop environments.

FEATURES

- Intuitive design and layout – easy to learn and use
- Positive, tactile-feel button activation
- Long battery life
- CE compliant
- Data output to SPC on all models
- Choice of Basic, Standard and Advanced feature levels
- Fixed ratio measurement systems available
- Compatible with 25 Indicator backs
- Origin set, zero set
- All compatible with 2900 SCM, SCU and SCKB cables
- Counting direction switching (±)



| Inch/Metric -.375" Stem - #4-48 UNF Thread | | | | | | | | | | | | | | | | |
|--|-------|-------|----|--------------------|------------|----------|--------|---------------------|-----------|--------------|--------------|-----------|------------------------------|------------------------|------------------|------------------|
| Cat. No. | EDP | Range | | Resolution | | Accuracy | | Additional Features | | | | Ftr. Lock | Max/Min/Runout Value Holding | True Abs. Sensor Tech. | Lug On Ctr. Bck. | CR2032 Btry. (2) |
| | | in | mm | in | mm | in | mm | in/mm Cnv. | Limit Set | Value Preset | Reading Hold | | | | | |
| 2900-1 | 09980 | .5 | 12 | .0005 | 0.001 | ±.00012 | ±0.003 | x | | | | | | x | x | x |
| 2900-2 | 09981 | .5 | 12 | .0001 | 0.002 | ±.00012 | ±0.003 | x | | | | | | x | | |
| 2900-4 | 09983 | .5 | 12 | .0005/.0001/.00005 | 0.01/0.001 | ±.00012 | ±0.003 | x | x | x | x | x | x | x | x | x |
| 2900-6 | 09985 | .5 | 12 | .0005/.0001/.00005 | 0.01/0.001 | ±.00012 | ±0.003 | x | x | x | x | x | x | x | x | x |
| 2900-1-1 | 09960 | 1 | 25 | .0005 | 0.001 | ±.00012 | ±0.003 | x | | | | | | x | x | x |
| 2900-2-1 | 09962 | 1 | 25 | .0001 | 0.01 | ±.00012 | ±0.003 | x | | | | | | x | | |
| 2900-3-1 | 09963 | 1 | 25 | .0005 | 0.01 | ±0.001 | ±0.03 | x | | | | | | | x | x |
| 2900-4-1 | 09965 | 1 | 25 | .0005/.0001/.00005 | 0.01/0.001 | ±.00012 | ±0.003 | x | x | x | x | x | x | x | x | x |
| 2900-5-1 | 09967 | 1 | 25 | .0005 | 0.01 | ±0.001 | ±0.03 | x | x | x | | | | | x | x |
| 2900-6-1 | 09969 | 1 | 25 | .0005/.0001/.00005 | 0.01/0.001 | ±.00012 | ±0.003 | x | x | x | x | x | x | x | x | x |
| 2900-1-2 | 72676 | 2 | 50 | .00005 | 0.001 | ±.00012 | ±0.003 | x | | | | | | x | x | x |
| 2900-4-2 | 72677 | 2 | 50 | .0005/.0001/.00005 | 0.01/0.001 | ±.00012 | ±0.003 | x | x | x | x | x | x | x | x | x |
| 2900-6-2 | 72678 | 2 | 50 | .0005/.0001/.00005 | 0.01/0.001 | ±.00012 | ±0.003 | x | x | x | x | x | x | x | x | x |

| Inch/Metric - 8mm Stem - M2.5 x 0.45 Thread | | | | | | | | | | | | | | | | |
|---|-------|-------|----|--------------------|------------|----------|--------|---------------------|-----------|--------------|--------------|-----------|------------------------------|------------------------|------------------|------------------|
| Cat. No. | EDP | Range | | Resolution | | Accuracy | | Additional Features | | | | Ftr. Lock | Max/Min/Runout Value Holding | True Abs. Sensor Tech. | Lug On Ctr. Bck. | CR2032 Btry. (2) |
| | | in | mm | in | mm | in | mm | in/mm Cnv. | Limit Set | Value Preset | Reading Hold | | | | | |
| 2900-1ME | 09971 | .5 | 12 | .0005 | 0.001 | ±.00012 | ±0.003 | x | | | | | | x | x | x |
| 2900-4ME | 09976 | .5 | 12 | .0005/.0001/.00005 | 0.01/0.001 | ±.00012 | ±0.003 | x | x | x | x | x | x | x | x | x |
| 2900-6ME | 09979 | .5 | 12 | .0005/.0001/.00005 | 0.01/0.001 | ±.00012 | ±0.003 | x | x | x | x | x | x | x | x | x |
| 2900-1ME-25 | 09972 | 1 | 25 | .0005 | 0.001 | ±.00012 | ±0.003 | x | | | | | | x | x | x |
| 2900-3ME-25 | 09975 | 1 | 25 | .0005 | 0.01 | ±0.001 | ±0.03 | x | | | | | | | x | x |
| 2900-4ME-25 | 09977 | 1 | 25 | .0005/.0001/.00005 | 0.01/0.001 | ±.00012 | ±0.003 | x | x | x | x | x | x | x | x | x |
| 2900-5ME-25 | 09978 | 1 | 25 | .0005 | 0.01 | ±0.001 | ±0.03 | x | x | x | x | | x | | x | x |
| 2900-6ME-25 | 09991 | 1 | 25 | .0005/.0001/.00005 | 0.01/0.001 | ±.00012 | ±0.003 | x | x | x | x | x | x | x | x | x |
| 2900-1ME-50 | 72679 | 2 | 50 | .00005 | 0.001 | ±.00012 | ±0.003 | x | | | | | | x | x | x |
| 2900-4ME-50 | 72681 | 2 | 50 | .0005/.0001/.00005 | 0.01/0.001 | ±.00012 | ±0.003 | x | x | x | x | x | x | x | x | x |
| 2900-6ME-50 | 72683 | 2 | 50 | .0005/.0001/.00005 | 0.01/0.001 | ±.00012 | ±0.003 | x | x | x | x | x | x | x | x | x |

| Metric Only - 8mm Stem - M2.5 x 0.45 Thread | | | | | | | | | | | | | | | | |
|---|-------|-------|----|------------|------------|----------|--------|---------------------|-----------|--------------|--------------|-----------|------------------------------|------------------------|------------------|------------------|
| Cat. No. | EDP | Range | | Resolution | | Accuracy | | Additional Features | | | | Ftr. Lock | Max/Min/Runout Value Holding | True Abs. Sensor Tech. | Lug On Ctr. Bck. | CR2032 Btry. (2) |
| | | in | mm | in | mm | in | mm | in/mm Cnv. | Limit Set | Value Preset | Reading Hold | | | | | |
| 2900-1M | 09986 | .5 | 12 | | 0.001 | | ±0.003 | | | | | | | x | x | x |
| 2900-4M | 09988 | .5 | 12 | | 0.01/0.001 | | ±0.003 | | x | x | x | x | x | x | x | x |
| 2900-6M | 09990 | .5 | 12 | | 0.01/0.001 | | ±0.003 | | x | x | x | x | x | x | x | x |
| 2900-1M-25 | 09961 | 1 | 25 | | 0.001 | | ±0.003 | | | | | | | x | x | x |
| 2900-3M-25 | 09964 | 1 | 25 | | 0.01 | | ±0.03 | | | | | | | | x | x |
| 2900-4M-25 | 09966 | 1 | 25 | | 0.01/0.001 | | ±0.003 | | x | x | x | x | x | | x | x |
| 2900-5M-25 | 09968 | 1 | 25 | | 0.01 | | ±0.03 | | x | x | x | | x | | x | x |
| 2900-6M-25 | 09970 | 1 | 25 | | 0.01/0.001 | | ±0.003 | | x | x | x | x | x | x | x | x |
| 2900-1M-50 | 72680 | 2 | 50 | | 0.001 | | ±0.003 | | | | | | | x | x | x |
| 2900-4M-50 | 72682 | 2 | 50 | | 0.01/0.001 | | ±0.003 | | x | x | x | x | x | x | x | x |
| 2900-6M-50 | 72684 | 2 | 50 | | 0.01/0.001 | | ±0.003 | | x | x | x | x | x | x | x | x |

*Fixed ratios available with special order. (exception of 2900-5M-25)



ELECTRONIC INDICATORS

NEW!

INDICATORS AND GAGES

2700 BACKLIGHT ELECTRONIC INDICATORS

The 2700 Backlight Electronic Indicators are offered in 1", 2" and 4" ranges. The deep backlight color indicates tolerances to read the indicator at far distances, in poor lighting, and with limited operator experience. A CD drive is required to use the software.

| Cat. No. | EDP | Range | SPC Output | Accuracy | Resolution |
|----------|-------|-------|------------|-------------|------------|
| 2700-800 | 72758 | 1" | x | (±) 2. Res. | .0001" |
| 2700-801 | 72759 | 1" | x | (±) 2. Res. | .000050" |
| 2700-802 | 72760 | 2" | x | (±) 2. Res. | .0005" |
| 2700-803 | 72761 | 2" | x | (±) 2. Res. | .0001" |
| 2700-804 | 72762 | 4" | x | (±) 2. Res. | .0005" |
| 2700-805 | 72763 | 4" | x | (±) 2. Res. | .0001" |

Accessories, Power Source, Cables

| Part No. | EDP | Description |
|----------|-------|--|
| PT60646 | 72592 | Cable to SPC computer, not foot switch |
| 2700SCKB | 69891 | USB cable to PC (In focused window), all 2700 Series |
| 2700SCU | 23956 | USB Cable, all 2700 Series |
| 2700SCM | 69896 | SmartCable Gage MUX - all 2700 Series |

Backs/Lever*

| Part No. | EDP | Description |
|----------|-------|----------------------------------|
| PT26406 | 65886 | Flat back |
| PT26407 | 65887 | Offset lug back |
| PT26411 | 65891 | Adjustable lug back |
| PT26408 | 65888 | Adjustable back |
| PT26409 | 65889 | Post-type back |
| PT26410 | 65890 | Screw bracket back |
| PT26848 | 66293 | Adjustable mounting bracket back |
| PT26405 | 65885 | Lifting lever |

*Other backs, styles and accessories also available by request.

FEATURES

- Backlight relates a reading to tolerance values
- SPC Cables USB, MTI, RS232
- Inch/metric display
- Analog visual display
- Travel reverse
- Maximum reading hold
- Display/freeze hold
- Single gage simple data collection included
- Floating zero
- Minimum reading hold
- Abs./preset measuring mode
- T.I.R. with low and high storage recall
- Lock combination
- USB/AC power cable included
- Software included
- AC power source



ELECTRONIC INDICATORS

2700 WISDOM ELECTRONIC INDICATORS

The 2700 Wisdom Electronic Indicator is one of the most versatile of the electronic indicators. All indicators feature a glass scale design with an unsurpassed accuracy of \pm two resolutions when measuring from a known standard. All have rugged, sealed enclosures as well.

FEATURES

- 8 resolutions and 4 measuring ranges available
- Plus or minus travel direction
- Zero the tool at any position of the spindle
- Rotating bezel
- Auto Off after 10 minutes of non-use
- Three power sources - operate by battery, A/C adapter or through data port
- Output jack allows data transmission



Inch/Metric - .375" Stem - #4-48 UNF Thread

| Cat. No. | EDP | Range | | Resolution | | Accuracy | |
|-----------|-------|-------|-----|-------------------------|-----------------------|-------------|-------------|
| | | in | mm | in | mm | in | mm |
| F2720IQ | 49508 | 0.6 | 15 | .001/.0005/.0001/.00005 | 0.02/0.01/0.002/0.001 | \pm .0001 | \pm 0.002 |
| F2720AD | 49500 | 0.6 | 15 | .001/.0005/.0001/.00005 | 0.02/0.01/0.002/0.001 | \pm .0001 | \pm 0.002 |
| F2720-1AD | 00043 | 0.6 | 15 | .001/.0005/.0001 | 0.02/0.01/0.002 | \pm .0001 | \pm 0.002 |
| F2730IQ | 49509 | 1 | 25 | .001/.0005/.0001/.00005 | 0.02/0.01/0.002/0.001 | \pm .0001 | \pm 0.002 |
| F2730-1IQ | 49516 | 1 | 25 | .001/.0005/.0001 | 0.02/0.01/0.002 | \pm .0002 | \pm 0.004 |
| F2730AD | 49501 | 1 | 25 | .001/.0005/.0001/.00005 | 0.02/0.01/0.002/0.001 | \pm .0001 | \pm 0.002 |
| F2730-1AD | 00045 | 1 | 25 | .001/.0005/.0001 | 0.02/0.01/0.002 | \pm .0002 | \pm 0.004 |
| F2740IQ | 49510 | 2 | 50 | .001/.0005/.0001 | 0.02/0.01/0.002 | \pm .0002 | \pm 0.004 |
| F2740AD | 49502 | 2 | 50 | .001/.0005/.0001 | 0.02/0.01/0.002 | \pm .0002 | \pm 0.004 |
| F2750IQ | 49511 | 4 | 100 | .001/.0005/.0001 | 0.02/0.01/0.002 | \pm .0002 | \pm 0.004 |
| F2750AD | 49503 | 4 | 100 | .001/.0005/.0001 | 0.02/0.01/0.002 | \pm .0002 | \pm 0.004 |

Inch/Metric - 8mm Stem - M2.5 x 0.45 Thread

| Cat. No. | EDP | Range | | Resolution | | Accuracy | |
|------------|-------|-------|-----|-------------------------|-----------------------|-------------|-------------|
| | | in | mm | in | mm | in | mm |
| F2720IQM | 49512 | 0.6 | 15 | .001/.0005/.0001/.00005 | 0.02/0.01/0.002/0.001 | \pm .0001 | \pm 0.002 |
| F2720ADM | 49504 | 0.6 | 15 | .001/.0005/.0001/.00005 | 0.02/0.01/0.002/0.001 | \pm .0001 | \pm 0.002 |
| F2720-1ADM | 09993 | 0.6 | 15 | .001/.0005/.0001 | 0.02/0.01/0.002 | \pm .0002 | \pm 0.004 |
| F2730IQM | 49513 | 1 | 25 | .001/.0005/.0001/.00005 | 0.02/0.01/0.002/0.001 | \pm .0001 | \pm 0.002 |
| F2730-1IQM | 09992 | 1 | 25 | .001/.0005/.0001 | 0.02/0.01/0.002 | \pm .0002 | \pm 0.004 |
| F2730ADM | 49505 | 1 | 25 | .001/.0005/.0001/.00005 | 0.02/0.01/0.002/0.001 | \pm .0001 | \pm 0.002 |
| F2730-1ADM | 09994 | 1 | 25 | .001/.0005/.0001 | 0.02/0.01/0.002 | \pm .0002 | \pm 0.004 |
| F2740IQM | 49514 | 2 | 50 | .001/.0005/.0001 | 0.02/0.01/0.002 | \pm .0002 | \pm 0.004 |
| F2740ADM | 49506 | 2 | 50 | .001/.0005/.0001 | 0.02/0.01/0.002 | \pm .0002 | \pm 0.004 |
| F2750IQM | 49515 | 4 | 100 | .001/.0005/.0001 | 0.02/0.01/0.002 | \pm .0002 | \pm 0.004 |
| F2750ADM | 49507 | 4 | 100 | .001/.0005/.0001 | 0.02/0.01/0.002 | \pm .0002 | \pm 0.004 |



ELECTRONIC INDICATORS

.250"/6MM AND .600"/15MM MODELS

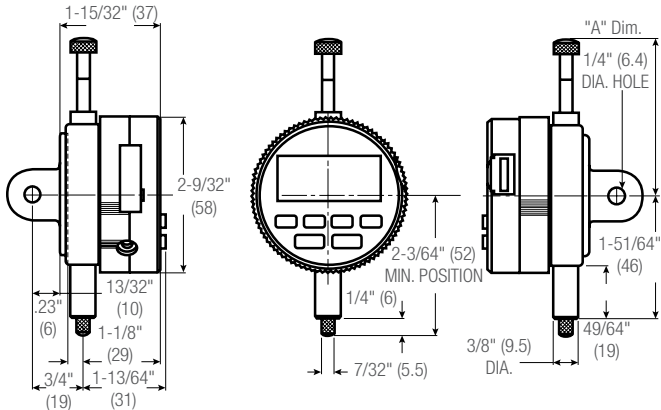

| Travel | | A Dimension | |
|--------|-----|-------------|----|
| in | mm | in | mm |
| .600 | 15 | 2-13/32 | 61 |
| .250 | 6.4 | 2-1/16 | 52 |

1"/25MM MODELS

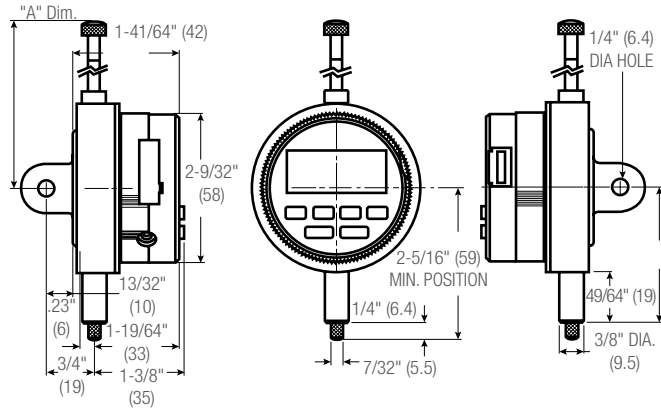

| Travel | | A Dimension | |
|--------|------|-------------|----|
| in | mm | in | mm |
| 1 | 25.4 | 2-7/8 | 73 |

2"/50 MM MODELS

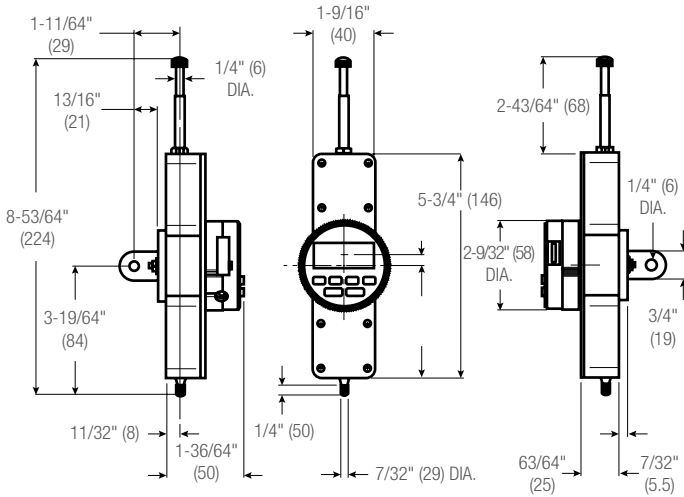

4"/100MM MODELS

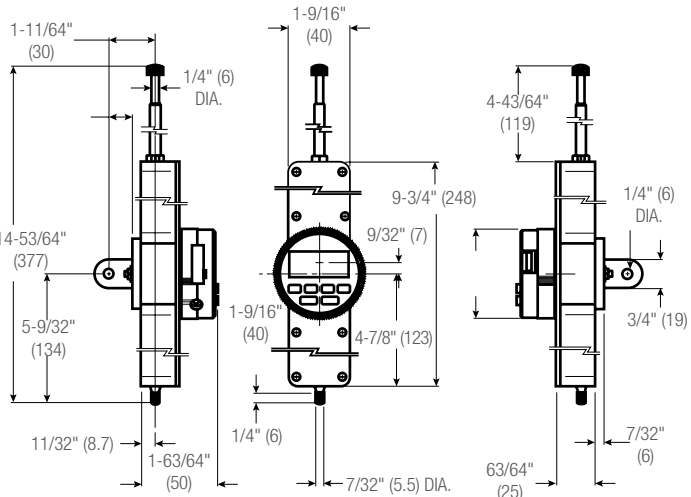

Accessories, Power Source, Cables

| Part No. | EDP | Description |
|----------|-------|---|
| PT26413 | 65880 | A/C Adapter, 110-Volt |
| PT26404 | 65884 | Replacement Zinc Air Batteries, 4-Pack |
| PT61120 | 65446 | Replacement Battery, 1-Pack (req. 2) |
| PT61489 | 65904 | Cable to Module PT61490, to Connect to 772 Data Collectors and 761 Multiplexers |
| PT26415 | 65882 | Cable for Wisdom Indicator to Wisdom Remote Display |
| PT26441 | 65893 | USB Cable to RS232 (PC/Compatible) |
| 2700SCM | 69896 | 7612 Data Multiplexer Gage Interface |

Backs/Lever*

| Part No. | EDP | Description |
|----------|-------|----------------------------------|
| PT26406 | 65886 | Flat Back |
| PT26407 | 65887 | Offset Lug Back |
| PT26411 | 65891 | Adjustable Lug Back |
| PT26408 | 65888 | Adjustable Back |
| PT26409 | 65889 | Post-Type Back |
| PT26410 | 65890 | Screw Bracket Back |
| PT26848 | 66293 | Adjustable Mounting Bracket Back |
| PT26405 | 65885 | Lifting Lever |

* Other backs, styles and accessories also available by request. To order contact points individually, see previous pages.

Extension Cables

| Part No. | EDP | Description |
|----------|-------|-------------------------------------|
| PT05679 | 68752 | 6' Extension Cable |
| 2700SCKB | 69891 | USB cable to PC (In focused window) |

Backs/Lever*

| Part No. | EDP | Description |
|----------|-------|----------------------------------|
| PT26406 | 65886 | Flat Back |
| PT26407 | 65887 | Offset Lug Back |
| PT26411 | 65891 | Adjustable Lug Back |
| PT26408 | 65888 | Adjustable Back |
| PT26409 | 65889 | Post-Type Back |
| PT26410 | 65890 | Screw Bracket Back |
| PT26848 | 66293 | Adjustable Mounting Bracket Back |
| PT26405 | 65885 | Lifting Lever |

*Other backs, styles and accessories also available by request. To order contact points individually, see previous pages.
NOTE: Probe and display resolutions must be the same for accurate readings.



ELECTRONIC INDICATORS

2700 GROUP 1 DIGITAL INDICATORS

AGD GROUP 1

FEATURES

- 270 degree Rotating Bezel - Allows viewing at different attitudes
- Smaller Diameter - A dimensional match to AGD Group one mechanical indicators (1.700"/43mm)
- Two Available Displays - Single LCD Numeric IQ model (largest of its class) with low battery warning and programmable ratios or Numeric/Analog AD model showing its two displays simultaneously
- .400 travel
- Allows storage of 200 readings internally and viewed, stored readings can be downloaded with included software and USB style cable
- Easy wired communication with cables or using Starrett DataSure® wireless (contact Starrett)
- Long battery life (with one CR232 cell) 3,000 hours under typical use also can be powered by plugging into your computer

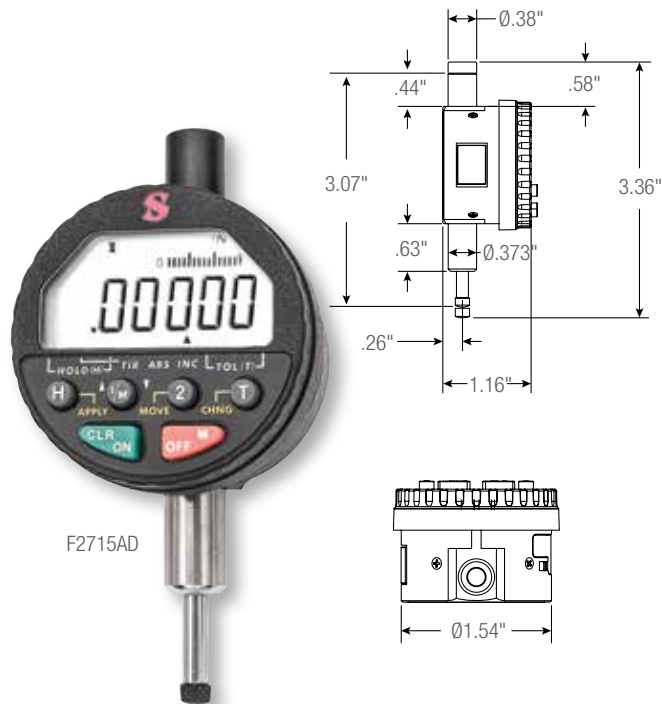

F2715AD

| Inch/Metric - 8mm Stem - M2.5 x 0.45 Thread | | | | | | | |
|---|-------|-------|----|-------------------------|-----------------------|----------|--------|
| Cat. No. | EDP | Range | | Resolution | | Accuracy | |
| | | in | mm | in | mm | in | mm |
| F2715IQ | 72970 | 0.4 | 10 | .001/.0005/.0001/.00005 | 0.02/0.01/0.002/0.001 | ±.0001 | ±0.002 |
| F2715AD | 72971 | 0.4 | 10 | .001/.0005/.0001/.00005 | 0.02/0.01/0.002/0.001 | ±.0001 | ±0.002 |
| F2714IQ | 73273 | 0.4 | 10 | .001/.0005/.0001 | 0.02/0.01/0.002 | ±.0001 | ±0.002 |
| F2714AD | 73274 | 0.4 | 10 | .001/.0005/.0001 | 0.02/0.01/0.002 | ±.0001 | ±0.002 |

3900 ELECTRONIC INDICATORS

AGD GROUP 2

RANGES UP TO .500" AND 12.7MM

The 3900 Electronic Indicators have simple, powerful, easy-to-use functions, all at an attractive price. Versions are available for inch/metric and metric only.

FEATURES

- Large, easy-to-read LCD
- Power On/Off button
- Reverse travel (± control indicates direction)
- Zero setting at any position
- Long battery life
- 3/8" diameter stem for inch/mm model (8mm on metric-only model)
- 4-48 spindle thread on inch/mm model (M2.5 X .45 thread on metric-only model)
- Lug-on-center back with additional flat back
- Dust cap
- Plastic storage case with clear cover



3900-5

| Cat. No. | EDP | Range | | Resolution | | Accuracy | |
|----------|-------|-------|------|------------|------|----------|-------|
| | | in | mm | in | mm | in | mm |
| 3900-5 | 72538 | .5 | 12.7 | .0005 | 0.01 | ±0.001 | ±0.03 |
| 3900M-5 | 72537 | | 12.7 | | 0.01 | | ±0.03 |

| Accessory | | |
|-----------|-------|--------------|
| Cat. No. | EDP | Description |
| PT61918 | 67169 | SR44 battery |



INDICATOR HOLDERS

3670 DIAL INDICATOR STANDS

The 3670 Dial Gage Stands are versatile and easily adapted to thickness gages for comparator work.

A perfect companion for the 647 Comparator Indicator.

FEATURES

- Designed for comparison measurements using a dial indicator or digital indicator
- Vertical fine adjustment is standard on all models
- Rugged bracket holds indicator firmly in place
- Can be used with any A.G.D. dial or digital indicator
- Furnished with a serrated or flat anvil which is ground an lapped and removable



3671 with 647M
Comparator Indicator

| 3670 Dial Gage Stands (3/8" stem hole; 8mm bushing) | | |
|---|-------|--|
| Cat. No. | EDP | Description |
| 3671 | 69901 | Indicator stand with round flat anvil |
| 3672 | 69902 | Indicator stand with round serrated anvil |
| 3673 | 69903 | Indicator stand with square serrated anvil |



3671



3672



3673

NEW!

INDICATORS AND GAGES



INDICATOR HOLDERS

657 INDICATOR HOLDERS

Base has three precision ground, magnetic contact surfaces. Grips horizontally, vertically or upside down. V-step holds base to round surfaces. Extra #1/4-20 tapped hole in one side of base (not shown) for mounting post.

Available with or without Starrett AGD Dial Indicators: inch reading 25-131J (graduation .0005", dial reading 0-25-0, range .125") or millimeter reading 25-181J (graduation 0.01mm, dial reading 0-50-0, range 2.5mm). Other indicators can be furnished on request.

- A. 657P Magnetic Base. 1-15/16" x 1-5/8" x 1-7/8" (50 x 40 x 48mm) deep. Push button on/off switch for one-hand operation.
- B. 657G Upright Base Post. 3/8" (9.5mm) diameter x 7-7/16" (190mm) length overall.
- C. 657H Swivel Post Snug. Allows universal indicator adjustment – up-and-down, any vertical angle, for a complete 360°. Two 3/8" (9.5mm) holes.
- D. PT06784-A Gage Holding Rod. 3/8" x 9-1/2" (9.5 x 240mm) with clamping mechanism for gripping the indicator lug back (see photo below).
- E. F. 57S and 58S Universal Snugs. Adapt various scribes and indicator shanks to rods and posts.

657 Base Holder Assembly and Individual Components

| Photo Key | Cat. No. | EDP | Description |
|-----------|-----------|-------|--|
| | 657D | 52749 | Magnetic Base, Upright Post Assembly Including Post, Swivel Post Snug and Gage Holding Rod |
| A | 657P | 52757 | Magnetic Base Only |
| B | 657G | 52753 | Upright Base Post Only |
| C | 657H | 52785 | Swivel Post Snug Only |
| D | PT06784-A | 52755 | Gage Holding Rod with Clamp Mechanism |
| E | 57S | 50296 | Universal Snug with 5/16" and 3/8" Hole Dia. |
| F | 58S | 56613 | Universal Snug with 1/4", 5/16" and 3/8" Hole Dia. |

Sets Including Magnetic Base, Upright Post Assembly and AGD Dial Indicators

| w/Finished Wood Case | | Without Case | | Description |
|----------------------|-------|--------------|-------|--|
| Cat. No. | EDP | Cat. No. | EDP | |
| 657EZ | 52751 | 657E | 52750 | Base and Upright Post Assembly with Inch Reading Indicator 25-131J |
| 657MEZ | 56358 | 657ME | 56357 | Base and Upright Post Assembly with Millimeter Reading Indicator 25-181J |

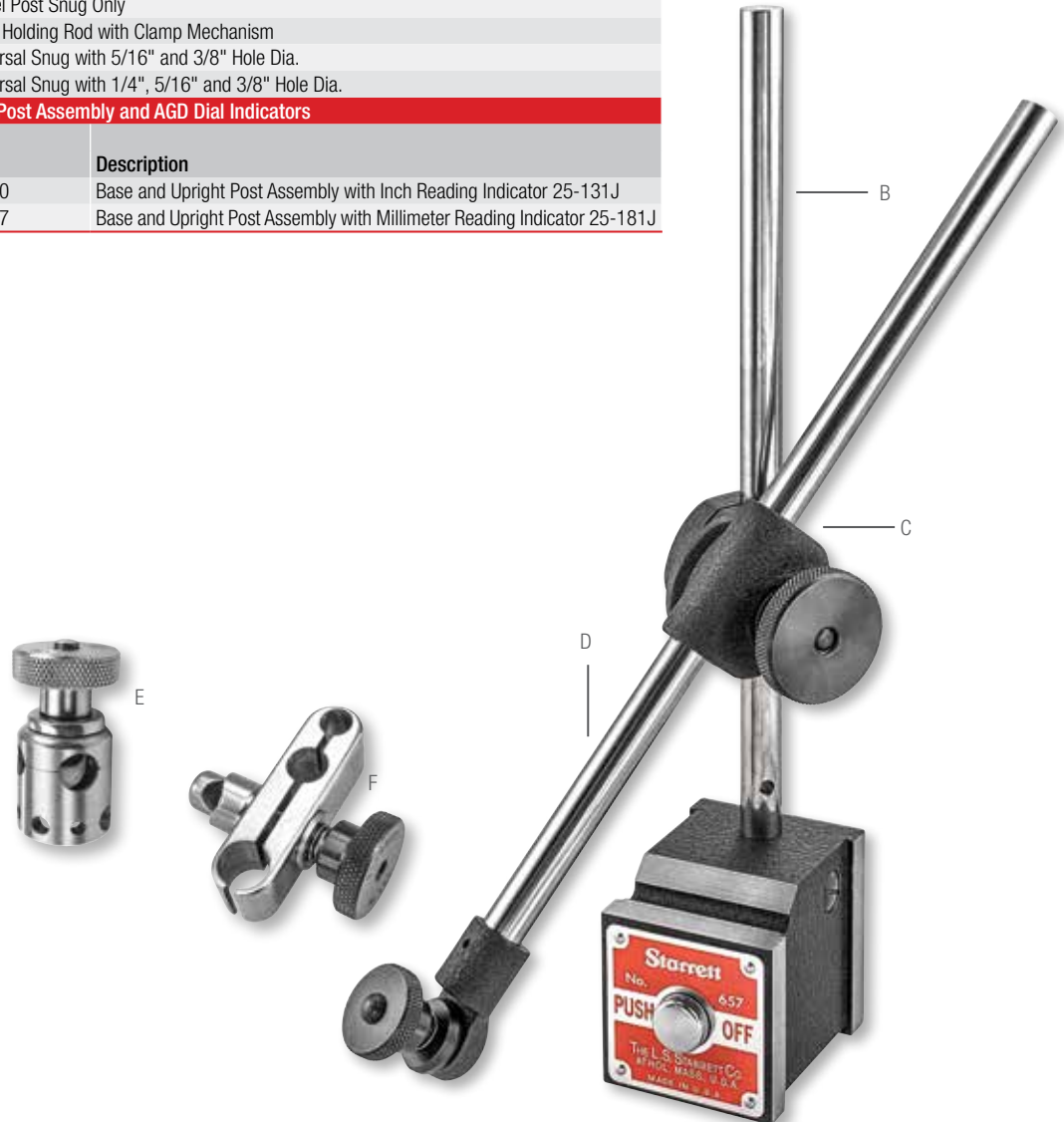

INDICATOR HOLDERS

657AA MAGNETIC BASE INDICATOR HOLDER

For use with all Starrett Test, Back-Plunger, AGD, Dial and Miniature-Dial Indicators. Also accommodates similar indicators of other manufacturers.

- A. 657P Magnetic Base. 1-15/16 x 1-5/8 x 1-7/8" (50 x 40 x 48mm). Push-button on/off switch for one-hand operation. Base has three precision ground magnetic contact points. Grips horizontally, vertically, and upside down. V-step holds base to arbors, shafts, etc. Base has extra 1/4-20 tapped hole on one side for mounting post. Black wrinkle finish on non-working surfaces.
- B. 657G Upright Base Post. 3/8" (9.5mm) diameter x 7-7/16" (190mm) length overall. 57S and 58S Universal Snugs may also be used.
- C. 657S Snug. Two 1/4" (6.3mm) diameter holes. Adapts 196, 650, and 651 Dial Indicators and 657Y Indicator Attachment to 657X Rod.
- D. 657X Rod. 1/4" (6.3mm) diameter x 6" (150mm) long. Accommodates Starrett 708, 709, 811 and 711F Dial Test Indicators and 657S Sleeve.
- E. 657Y Indicator Attachment. 1/4" (6.3mm) O.D. one end, other end threaded and fits lug backs of all AGD indicators (81, 25, 655, 656) and 80 Miniature Indicators.
- F. PT18724 Snug. 3/8" (9.5mm) diameter post hole. 1/4" (6.3mm) diameter gripping hole accommodates 657X Rod.



INDICATORS AND GAGES

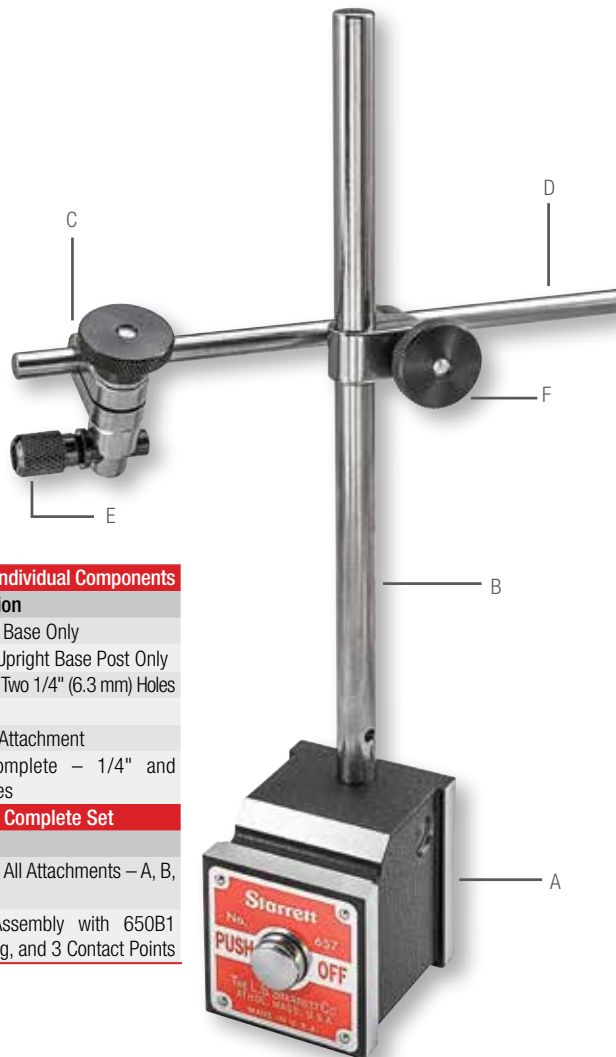

657AA Magnetic Base Indicator Holder - Individual Components

| Photo Key | Cat. No. | EDP | Description |
|-----------|----------|-------|-------------------------------------|
| A | 657P | 52757 | Magnetic Base Only |
| B | 657G | 52753 | 7-7/16" Upright Base Post Only |
| C | 657S | 52759 | Snug with Two 1/4" (6.3 mm) Holes |
| D | 657X | 52764 | Rod |
| E | 657Y | 52765 | Indicator Attachment |
| F | PT18724 | 50710 | Snug Complete - 1/4" and 3/8" Holes |

657AA Magnetic Base Indicator Holder - Complete Set

| Cat. No. | EDP | Description |
|----------|-------|--|
| 657AA | 52743 | Magnetic Base with All Attachments - A, B, C, D, E, F |
| 657-650Z | 65259 | Base and Post Assembly with 650B1 Indicator, 657S Snug, and 3 Contact Points |



INDICATOR HOLDERS

657A MAGNETIC BASE INDICATOR HOLDER WITH SWIVEL POST ASSEMBLY

The swivel post assembly on these holders provides universal adjustment in both horizontal and vertical planes. Available with inch or millimeter Dial Test or Back-Plunger Indicators, they save time in shop set-up and other inspection jobs.

For use with all Test, Back-Plunger, AGD, Dial and Miniature-Dial Indicators. Also accommodates similar indicators of other manufacturers.

Powerful, permanent magnetic base holds firmly to steel or iron surfaces – horizontally, vertically, upside-down. Push-button turns magnetic force on or off for quick, one-hand set-up and take-down. V-step adapts base to horizontal or vertical arbors and chucks. There is an extra 1/4-20 NC tapped hole in side of base for indicator mounting post. Three precision ground magnetic contact surfaces (plus V-step). Black wrinkle finish on non-working surfaces.

MAGNETIC BASE ASSEMBLY FEATURES:

- A. 657P Magnetic Base is 1-15/16" x 1-5/8" x 1-7/8" (50 x 40 x 48mm) deep.
- B. Swivel Cap Slot permits 90° post travel to horizontal position.
- C. Post rotates 360°.
- D. 657F Indicator Swivel Post Assembly is 6-1/2" (165mm) high (less threaded end). Assembly consists of items B, C, E, F, G.
- E. Fine-Adjusting Screw. Turn to zero set indicator.
- F. Upper arm is 2" (50mm) long with a 5/16" (8mm) diameter and swings more than 180°; friction joint holds it in position.
- G. 7/32" (5.5mm) diameter step, 1/2" (13mm) long.

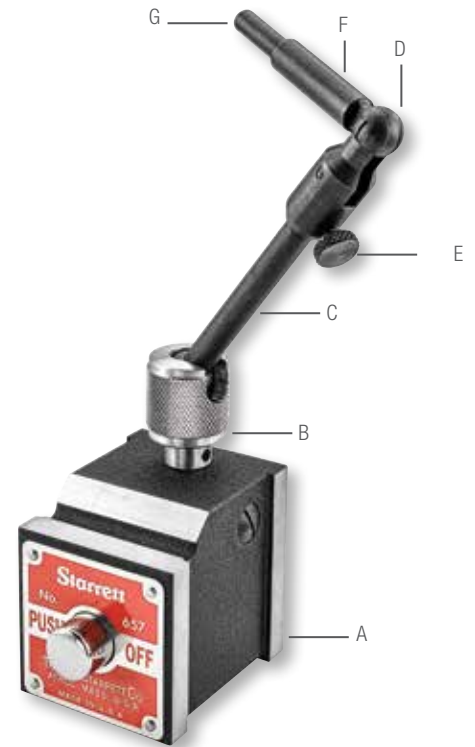

657A with 196B1 Universal Dial Indicator setting up workpiece on milling machine.



657A with 711LS Last Word Dial Test Indicator setting up workpiece on surface grinder.

657A Magnetic Base Indicator Holder - Individual Components

| Cat. No. | EDP | Description |
|----------|-------|---|
| 657A | 52744 | Magnetic Base with Swivel Post Assembly |
| 657P | 52757 | Magnetic Base Only |
| 657F | 52752 | Swivel Post Assembly Only |

657 SETS

These sets have been put together for your ordering convenience, but you can mix and match other Starrett test or back-plunger indicators and attachments with the 657A Magnetic Base and Swivel Post Assembly to suit your needs.

657T Flex-O-Post Indicator Holders with magnetic base - Individual Components

| Photo Key | Cat. No. | EDP | Description |
|-----------------|----------|-------|--|
| F | 657P | 52757 | Magnetic Base Only |
| (A, B, C, D, E) | 3657U | 12695 | Flex-O-Post with Locking Lever and Snug Only |
| G | 657W | 52763 | Fine-Adjustment Attachment |
| A | PT17850 | 72400 | Indicator Holding Rod |

657T Flex-O-Post Indicator Holders with magnetic base - Complete Assemblies

| Cat. No. | EDP | Description |
|----------|-------|--|
| 657T | 52760 | Magnetic Base with Flex-O-Post Assembly |
| 657TW | 52761 | Magnetic Base with Flex-O-Post Assembly and Fine-Adjustment Attachment |



INDICATOR HOLDERS

657T Flex-O-Post Indicator Holders with Magnetic Base

For use with all Starrett Test, Back-Plunger, AGD, Dial, and Miniature Dial Indicators. Also accommodates similar indicators of other manufacturers. The flexible post is an assembly of short tubular steel sections and precision ball joints, linked by an internal steel cable. It can be adjusted to any position and locked by turning a lever near the magnetic base. This makes it possible to use indicators in awkward places that are hard to reach with conventional holding devices.

Assembled to the magnetic base, the post has a vertical reach of approximately 15" (380mm) and a horizontal reach of approximately 10" (250mm). The indicator snug on the end of the post can be rotated through 360° and locked in any position.

The base has three precision ground magnetic contact surfaces. Grips horizontally, vertically or upside down. V-step holds base to arbors, shafts, chucks.

The 657W Attachment allows fine adjustments to be made, operated by turning the fine-adjusting thumb screw (with post locked in rigid position) to zero, then set the indicator.

- A. Gage Rod. 3/8" x 3" (9.5mm x 75mm) has 5/16, 1/4 and 7/32" (8, 6.3, and 5.5mm) steps. Holds 708, 709, 711 and 811 Dial Test Indicators by body clamp. See attachment specifications for the appropriate indicator body clamp on previous pages.
- B. Adjusting Take-up Sleeve with locking nut for maintaining proper degree of post rigidity.
- C. Post Snug has 3/8" (9.5mm) hole (which will also grip AGD dial indicators by the stem).
- D. Flex-O-Post 3657U.
- E. Locking Lever tightens internal steel cable to make post rigid and lock it in position.
- F. Magnetic Base 657P has push-button on/off switch.



651B1 Indicator gripped directly to its stem via the post snug.



196B1 Indicator via a 657S Snug.

657T Flex-O-Post Indicator Holders with magnetic base - Individual Components

| Photo Key | Cat. No. | EDP | Description |
|-----------------|----------|-------|--|
| F | 657P | 52757 | Magnetic Base Only |
| (A, B, C, D, E) | 3657U | 12695 | Flex-O-Post with Locking Lever and Snug Only |
| G | 657W | 52763 | Fine-Adjustment Attachment |
| A | PT17850 | 72400 | Indicator Holding Rod |

657T Flex-O-Post Indicator Holders with magnetic base - Complete Assemblies

| Cat. No. | EDP | Description |
|----------|-------|--|
| 657T | 52760 | Magnetic Base with Flex-O-Post Assembly |
| 657TW | 52761 | Magnetic Base with Flex-O-Post Assembly and Fine-Adjustment Attachment |

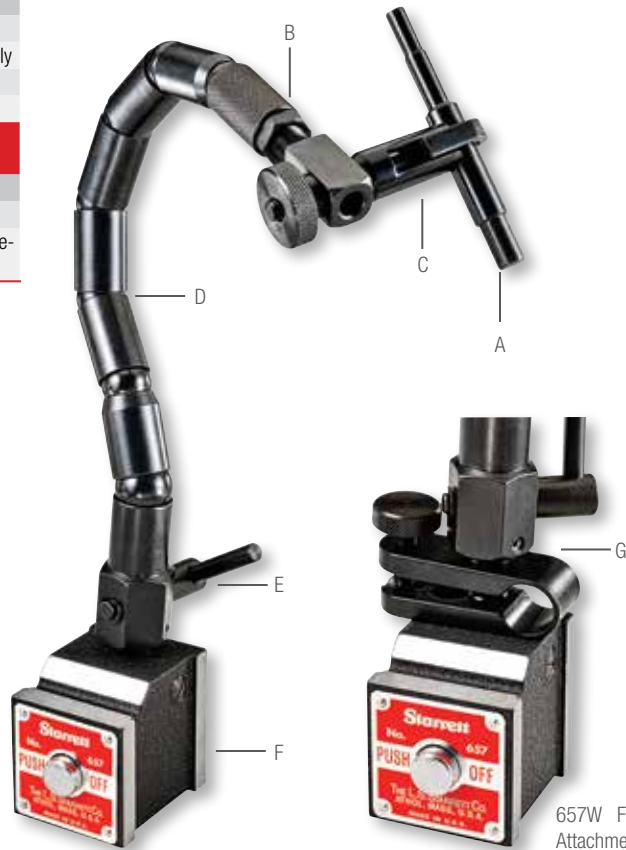

657W Fine-Adjustment Attachment



INDICATOR HOLDERS

657-1, 657-2 MAGNETIC BASE UNIVERSAL INDICATOR HOLDER

WITH TRIPLE JOINTED ARM AND FINE ADJUSTMENT

This versatile indicator holder has three pivots available for positioning the indicator where needed. All pivots are controlled by one tightening knob. It will hold:

- Any indicator with a 3/8" (9.5mm) stem (such as our 25, 650 and 651 Indicators)
- Any indicator with a standard dovetail mount (such as our 708, 709, and 811 Indicators)
- Any indicator with a 1/4" (6.3mm) shank (such as our 196 Indicator)
- Any indicator with a 3/16" (4.7mm) shank (such as our 708, 709, 811 and 711 Indicators)
- Any indicator with a body clamp (such as our 711 Indicators)
- The working area is within a hemisphere having a radius of approximately 12" (300mm)
- The very sensitive fine-adjustment is located on the magnetic base to eliminate indicator deflection when it is being adjusted
- The 657-3 Universal Indicator Holder Arm Assembly can also be used on the 659P Base using the 659 Thread Adapter, PT18318

657-1 and 657-2 Magnetic Base Universal Indicator Holders - Individual Components

| Photo Key | Cat. No. | EDP | Description |
|-----------|----------|-------|--|
| A | 657-3 | 64438 | Universal Indicator Holder Arm Assembly Only |
| B* | 657W | 52763 | Fine-Adjustment Attachment |
| C* | PT17850 | 72400 | Indicator Holding Rod |
| D | 657P | 52757 | Magnetic Base Only |
| E | 657S | 52759 | Snug with Two 1/4" (6.3 mm) Holes |

657-1 and 657-2 Magnetic Base Universal Indicator Holders - Complete Assemblies

| Cat. No. | EDP | Description |
|----------|-------|---|
| 657-1 | 64436 | Universal Indicator Holder, 657W Fine-Adjustment including 657P Magnetic Base, PT17850 Indicator Holding Rod, and 657S Snug |
| 657-2 | 64437 | Universal Indicator Holder with 657 Magnetic Base |

* Not included with the 657-2



660 MAGNETIC BASE INDICATOR HOLDER

WITH TRIPLE JOINTED ARM

The compact and versatile 660 Magnetic Base Indicator Holder has three adjustable pivots controlled by a single knob for fast, easy indicator positioning.

- Small but powerful magnetic base with 70lb (320N) holding force
- Positive On/Off switch
- Base Dimensions: 1-3/16" x 1-9/16" x 1-3/8" (30mm x 40mm x 35mm)
- Horizontal and vertical mounting positions
- Will hold any indicator with a 3/8" (9.5mm) stem or standard dovetail mount
- Articulating arm with powerful central locking knob, provides full 360° horizontal positioning and over 180° vertical positioning
- Maximum Horizontal Reach: 4.750" (120mm); Maximum Vertical Reach: 7.500" (190mm)
- Very sensitive fine-adjustment thumb screw

660 Magnetic Base Indicator Holder

| Cat. No. | EDP | Description |
|----------|-------|-----------------------|
| 660 | 68621 | Base Indicator Holder |



INDICATOR HOLDERS

661 MINI MAGNETIC INDICATOR HOLDER

The Mini Magnetic Tool Holder is a simple, versatile, effective and economical tool for a variety of indicator holding tasks. It has no levers or switches – simply place the holder on the measuring surface, attach the indicator and position as required.

FEATURES AND SPECIFICATIONS

- 30 lb (133 N) of holding force
- Base Diameter: 1.180" (30mm)
- Base Height: 1" (25.4mm)
- Overall Height 4.173" (106mm)
- Holds indicators with 3/8" stems or standard dovetail mounts
- Fits over spindles and posts with diameter of 1/4" (6.3mm), such as the 196 Dial Indicator
- Includes an 8mm adapter for indicators with metric (8mm) stems

| 661 Mini Magnetic Indicator Holder | | |
|------------------------------------|-------|------------------|
| Cat. No. | EDP | Description |
| 661 | 68620 | Indicator Holder |



659 HEAVY-DUTY MAGNETIC BASE INDICATOR HOLDER

WITH ROTARY ON/OFF SWITCH. FURNISHED WITH OR WITHOUT STARRETT AGD DIAL INDICATORS

This holder has a powerful magnetic base that attaches to flat surfaces or on round work up to 5" (125mm) in diameter by a form-ground involute vee for accurate seating. It has approximately twice the holding power of our 657 Magnetic Base and has a rotary on/off switch.

A post snug with two 3/4" (19mm) gripping holes positions the dial indicator at any height and at any vertical angle and allows for 360° rotation of the gage rod. After locking the gage in place, the final indicator setting is made by an independent fine adjustment at the back end of the gage rod.

A second tapped hole (3/8"-24) in one side of the base is for mounting the post horizontally or adding another post for multiple inspection work. The base is furnished with a threaded adapter, making it possible to use the 657 Magnetic Base post and attachments. Base and snug have a black wrinkle finish with precision ground contact surfaces.

Available with or without Starrett AGD Dial Indicators: inch reading 25-131J (.0005" graduation) or millimeter reading 25-181J (0.01mm graduation). Other mechanical AGD indicators are available on request. Electronic indicators, 2600 and 2700, are also available on request.

Both the upright post and the gage rod are approximately 9 3/8" (238mm) long and 3/4" (19mm) in diameter.

Base Holder Assembly and Individual Components

| Photo Key | Cat. No. | EDP | Description |
|-----------|----------|-------|--|
| | 659A | 56687 | Magnetic Base, Upright Post Assembly Including Post, Snug, Gage Rod with Clamp and Fine Adjust, and Thread Adapter, without Case |
| | 659AZ | 55947 | Complete Assembly (Above) in Case |
| P | 659P | 55949 | Magnetic Base, Including Thread Adapter |
| G | 659G | 56688 | Upright Base Post Only |
| H | PT16846 | 71597 | Swivel Post Snug Only with Two 3/4" (19mm) Gripping Holes |
| J | PT08903 | 72032 | Gage Holding Rod Only, Including Clamp Mechanism and Fine-Adjustment |
| | PT18318 | 72040 | Thread Adapter Only |

Sets, Including Magnetic Base, Upright Post Assembly and AGD Dial Indicators

| Cat. No. | EDP | Description |
|----------|-------|--|
| 659BZ | 55948 | Base and Upright Post Assembly with Inch Reading Indicator 25-131J in Case |
| 659MBZ | 64892 | Base and Upright Post Assembly with Millimeter Reading Indicator 25-181J in Case |

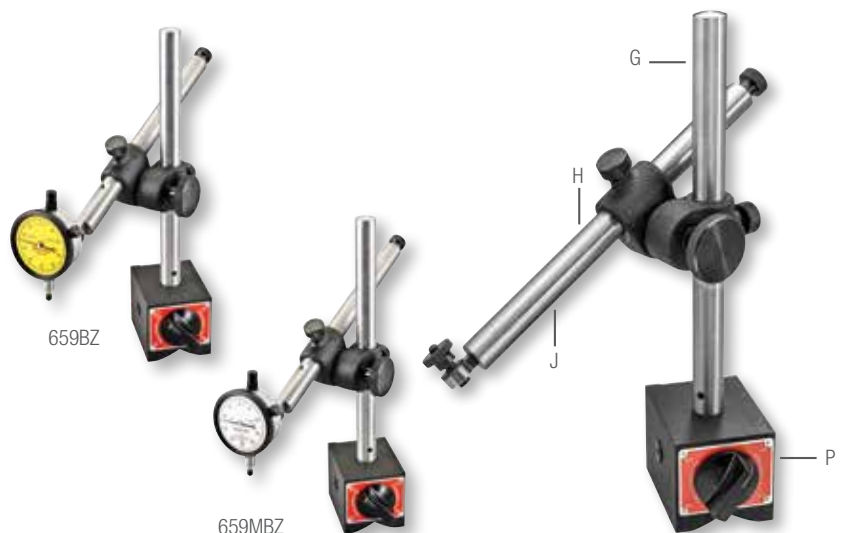

INDICATOR HOLDERS

COMMON TEST AND BACK PLUNGER INDICATOR APPLICATIONS

- A. Models with tool post holders, generally used for lathe work.
- B. Indicators may be used on our 665 Inspection Holder.
- B, C. Some indicator holders have flexible joints for holding in different places.
- C, D. Indicators with straight stems or shanks can be held in snugs or in chucks and collets.



REFERENCES FOR OTHER TEST INDICATOR HOLDING METHODS

In addition to the magnetic base indicator holders on the preceding pages, we also offer the following:

- A. For very precise measurements such as comparing a part to a gage block set, we have our 252 Height Transfer Gage with our DIGI-CHEK® Height Gages
- B. Any of our great variety of height gages - 250, 254, 255, and 3752 - can be used for comparing and for actual vertical measurements
- C. Our 57 or 257 Surface Gages. These are for comparison and the truing-up of surfaces

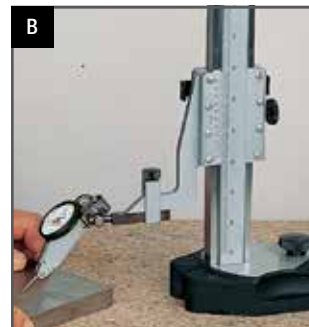

INDICATOR HOLDERS

665 INSPECTION HOLDER AND DIAL INDICATORS

This is the most versatile dial indicator holder with an extremely stable base (A) that is 8-1/2" (215mm) long x 2-1/4" (57mm) wide at the bottom. It can inspect workpieces on the top surface of the ground base or within a working area defined by the 8" (200mm) upright base post (B) and the 9-1/2" (238mm) long gage-holding rod (C). The base post can be conveniently located anywhere along the 8-1/2" (215mm) T-slot in the base.

This tool can be held in a vise or by a bolt in a machine T-slot coming up through one of the two 3/8" (9.5mm) holes in the base and fastening down on the top surface.

D. Swivel Post Snug 665D

Snug has a .375" (9.5mm) hole for the gage holding rod and a .465" (11.8mm) hole for the upright post. Also comes with the 665L Reducing Bushing (J) that can reduce the .465" (11.8mm) hole to 3/8" (9.5mm).

| Individual Components | | | |
|-----------------------|-----------|-------|--|
| Key | Cat. No. | EDP | Description |
| A | 665A | 52783 | Base Only |
| B | 665B | 52784 | Upright Base Post .464" x 8" (11.8 x 200mm) with Clamp Mechanism |
| C | PT06784-A | 52755 | Gage Holding Rod 3/8" x 9-1/2" (9.5 x 240mm) with Clamp Mechanism |
| D | 665D | 52754 | Swivel Post Snug with .465" and 3/8" (11.8 and 9.5mm) holes with 665L Reducing Bushing |
| G | 665G | 52792 | Clamp with .464" x 5-3/4" (11.8 x 146mm) Post |
| | 665G-1/4 | 52793 | Clamp with 1/4" (6.3mm) Diameter Post |
| | 665G-5/16 | 52794 | Clamp with 5/16" (7.9mm) Diameter Post |
| | 665G-3/8 | 52795 | Clamp with 3/8" (9.5mm) Diameter Post |
| H | 665H | 52790 | Tool Post Holder Approximately 1" x 7/16" (25 x 11mm) |
| I | 665G-1 | 52789 | Offset Arm 3/8" (9.5mm) Diameter 3" and 5 1/2" (75 and 140mm) Arms |
| J | 665L | 52756 | Reducing Bushing Only (for Swivel Post Snug) .465" (11.8mm) O.D. .375" (9.5mm) I.D. |

| Inspection Sets with AGD Dial Indicators | | |
|--|-------|---|
| Cat. No. | EDP | Description |
| 665JZ | 56275 | Complete with Components and 25-131J Inch Reading Indicator in Case |
| 665MJZ | 56276 | Complete with Components and 25-181J Millimeter Reading Indicator in Case |

Three very useful inspection combinations can be made by removing the complete swivel post snug and gage holding rod as follows:

G. Clamp 665G

Take the clamp and put the clamp post into the snug and lock it. Now this combination can be used to clamp the gage holding rod and the indicator into hard-to-reach places for inspecting jigs, fixtures, lining up work on centers and machine tables.

The clamp has a 3" (75mm) capacity and a post with an approximately 5-3/4" (145mm) length. The clamp post is .464" (11.8mm) diameter that fits into the regular swivel post snug 665D.

Three other clamp post diameter options available – 665G-3/8 is a 3/8" (9.5mm) diameter clamp post that can be used in the regular swivel post snug 665D with the addition of the 665L reducing bushing. The 665G-5/16 (7.9mm) and 665G-1/4 (6.3mm) can be used with other snugs to hold an indicator.

H. Tool Post Holder 665H

Put one end of the offset arm into the swivel post snug 665D (with the 665L reducing bushing in it). Then put this rectangular tool post holder 665H onto the other arm. This combination now allows for a good, tight setup in lathe tool posts and other machine setups.

I. Offset Arm 665G-1

Another very popular measuring combination is to put the reducing bushing (which is furnished) into the snug and then put one leg of the offset arm into it. Now the tool can be used in a 3/8" (9.5mm) chuck or collet to sweep a large area.

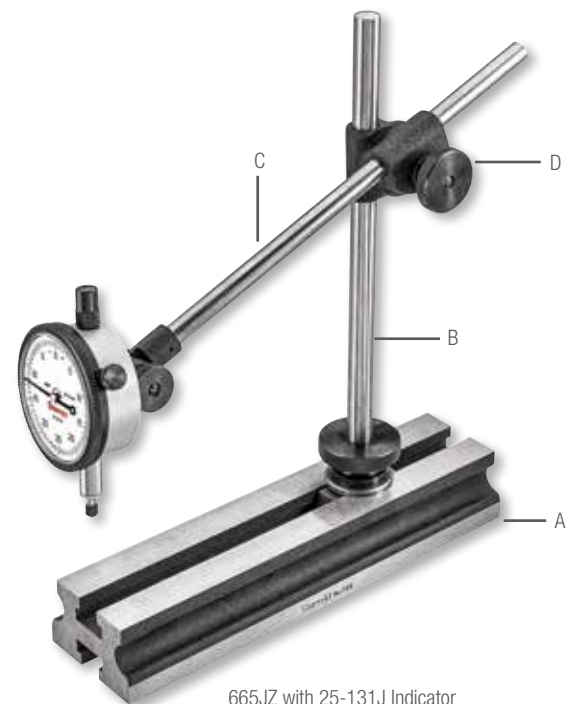

665JZ with 25-131J Indicator



INDICATOR HOLDERS

675 DIAL COMPARATORS WITH GRANITE BASE

Extremely rugged and universally adjustable to any position, these gages are well suited for inspection, layout, checking and lineup operations anywhere in the shop. All settings are individually made without disturbing others.

These versatile stands allow the indicator to be positioned at any height within the capacity of the upright base post – 360° both horizontally and vertically.

The indicator can also be moved lengthwise within the capacity of the 3/4" x 9-7/8" (19 x 250mm) horizontal gage-holding rod.

A special feature of this tool is the sensitive, fine-adjustment at the end of the gage rod. The fine-adjustment range is approximately 1/4" (6.3mm).

A 1/4" (6.3mm) steel indicator contact point is provided, but contact points in other lengths and materials are also available – see previous accessory pages.

This holder has a Starrett Grade-A Crystal Pink® Granite base that is 8" x 12" x 2" (200 x 300 x 50mm), and is finished to an overall tolerance of .0001" (0.0025mm).

NOTE: Not recommended for electronic indicators 2" and above.

| 675 Complete Units | | | | | |
|--------------------|-------|-------------------------------|--------------|-------|---------------|
| With Granite Base | | Dial Indicator Specifications | | | |
| Cat. No. | EDP | Graduation | Dial Reading | Range | Indicator No. |
| 675GJ | 55964 | .0005" | 0-25-0 | .125" | 25-131J |
| 675GMJ | 56129 | 0.01mm | 0-50-0 | 2.5mm | 25-181J |

| Individual Components | | |
|-----------------------|-------|---|
| Cat. No. | EDP | Description |
| 675G | 66051 | Granite Base, Upright Base Post and Gage Holding Rod, Including Clamp Mechanism and Fine-Adjustment |
| PT08903 | 72032 | Gage Holding Rod Only, Including Clamp Mechanism and Fine-Adjustment |
| PT16846 | 71597 | Swivel Post Snug Only with Two 3/4" (19mm) Gripping Holes |

Available with special non-shock mechanism or without indicator. Any Starrett AGD Dial or Electronic Indicator can be interchanged with indicators listed. Please specify when ordering.



653 DIAL COMPARATORS

WITH CAST IRON BASE, INCH AND MM READING

653G DIAL COMPARATORS

WITH GRANITE BASE, INCH AND MM READING

These bench-type comparator gages are ruggedly built for in-process and final inspection work.

The dial indicator can be adjusted vertically and locked in any position. A sliding ring with locking screw below the beam permits swinging the indicator to either side. The ring also acts as a safety device, preventing the beam from accidentally dropping. There is a fine adjustment on the beam for final indicator setting.

The hand lifting lever on the indicator raises the spindle and releases it to contact the work. Left hand lever furnished unless otherwise specified.

Both gages have a maximum vertical capacity of 9-1/4" (235mm) and a throat depth of 5" (125mm) and a vertical indicator fine adjustment of up to 1/2" (12.7mm). Post diameter is 1-1/2".

653 Dial Comparator has a precision ground cast iron base measuring approximately 8" x 9" (200 x 225mm).

653G Dial Comparator has a Starrett Grade A, Crystal Pink® Granite base, measuring 8" x 12" x 2" (200 x 300 x 50mm). Base is finished to an overall tolerance of .0001" (0.0025mm).

NOTE: Recommended for electronic indicators 2" and above.

| 653 Complete Units | | | | | | | |
|---------------------|-------|-------------------|-------|-------------------------------|------------|--------------|-------|
| With Cast Iron Base | | With Granite Base | | Dial Indicator Specifications | | | |
| Cat. No. | EDP | Cat. No. | EDP | Indicator No. | Graduation | Dial Reading | Range |
| 653J | 52737 | 653GJ | 55966 | 655-141J | .001" | 0-50-0 | .250" |
| 653MJ | 56146 | 653GMJ | 56127 | 655-181J | 0.01mm | | 2.5mm |

| Individual Components | | |
|-----------------------|-------|---|
| Cat. No. | EDP | Description |
| 653J | 55917 | Comparator with Cast Iron Base, without Indicator |
| 653G | 56646 | Comparator with Granite Base, without Indicator |

Available with special non-shock mechanism or without indicator. Any Starrett AGD Dial or Electronic Indicator can be interchanged with indicators listed. Please specify accordingly.



SPECIAL FUNCTION DIAL GAGES

This section includes special function dial gages that we list as regular items. Gages are also available with electronic indicators on request, where noted.

- Chamfer Gages
- Countersink Gages
- Hole Gages
- Bore Gages — See Bore Gage Section
- Direct-Reading Thickness Gages
- Snap Gages
- Groove Gages
- Caliper Gages
- Depth Gages
- Out-of-roundness Gages
- Inside Dial Gages
- Automotive Gages
- Crankshaft Distortion Gages
- Cylinder Gages
- Disc Brake Gages
- Large Diameter Gages

In addition, we have made many other special function gages to suit a wide variety of our customers' specific requirements. If you have a special application, we invite you to submit your drawings and specifications to our Special Order Department at 121 Crescent Street, Athol, MA 01331, USA. We will be happy to provide a prompt quotation.

SPECIAL FUNCTION INDICATORS

CHAMFER GAGES

FOR INTERNAL CHAMFERS:

683 CHAMFER GAGE 0-90°

684 CHAMFER GAGE 90-127°

FOR EXTERNAL CHAMFERS:

685 CHAMFER GAGE 0-90°

686 CHAMFER GAGE 90-127°

These gages directly measure the diameter of chamfered holes. No setting master is necessary. When the three-blade plunger is pressed against a flat surface, the gage should read the set number stamped on the back of the indicator. In case of wear, the gage may be adjusted to read the proper number.

All ground surfaces are of hardened tool steel. Indicators are AGD design.

Internal gages will measure the largest diameter of any chamfer that has an included angle within the range of angles printed on the dial face of the gage.

External gages will measure the smallest diameter of any chamfer within the range of angles printed on the dial face of the gage.

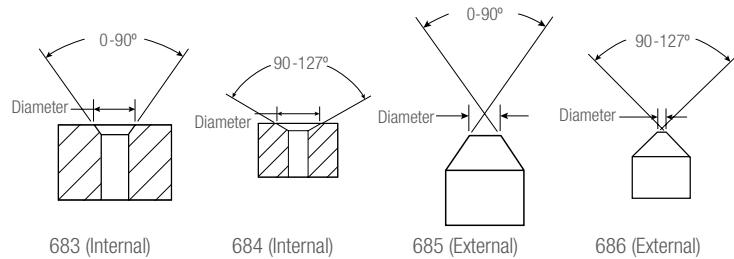

685-2Z Internal Chamfer Gage with 695 Check Stand with F2720-4IQ Electronic Indicator



| 683 Inch Reading Internal Gages | | | | | 684 Millimeter Reading Internal Gages with Yellow Dials | | | | |
|---------------------------------|-------|---------------|-------|----------|---|-------|---------------|-------|------------|
| 0-90° Angle | | 90-127° Angle | | | 0-90° Angle | | 90-127° Angle | | |
| Cat. No. | EDP | Cat. No. | EDP | Range | Cat. No. | EDP | Cat. No. | EDP | Range |
| 683-1Z | 63684 | 684-1Z | 63688 | 0-3/8" | 683M-1Z | 64989 | 684M-1Z | 64993 | 0-9.5mm |
| 683-2Z | 63685 | 684-2Z | 63689 | 0-1/2" | 683M-2Z | 64990 | 684M-2Z | 64994 | 0-12.7mm |
| 683-3Z | 63686 | 684-3Z | 63690 | 0-1" | 683M-3Z | 64991 | 684M-3Z | 64995 | 0-25mm |
| 683-4Z | 63687 | 684-4Z | 63691 | 1-2" | 683M-4Z | 64992 | 684M-4Z | 64996 | 25-50mm |
| 685 Inch Reading External Gages | | | | | 686 Millimeter Reading External Gages with Yellow Dials | | | | |
| 0-90° Angle | | 90-127° Angle | | | 0-90° Angle | | 90-127° Angle | | |
| Cat. No. | EDP | Cat. No. | EDP | Range | Cat. No. | EDP | Cat. No. | EDP | Range |
| 685-1Z | 63692 | 686-1Z | 63695 | 1/8-1/2" | 685M-1Z | 64997 | 686M-1Z | 65000 | 3.2-12.7mm |
| 685-2Z | 63693 | 686-2Z | 63696 | 3/16-1" | 685M-2Z | 64998 | 686M-2Z | 65001 | 4.7-25mm |
| 685-3Z | 63694 | 686-3Z | 63697 | 1-2" | 685M-3Z | 64999 | 686M-3Z | 65002 | 25-50mm |

Also available with electronic indicators. Please specify.
Gages furnished in deluxe padded case.



SPECIAL FUNCTION INDICATORS

COUNTERSINK GAGES

- 687 COUNTERSINK GAGE 82°
 688 COUNTERSINK GAGE 90°
 689 COUNTERSINK GAGE 100°

Starrett Countersink Gages are offered in three different angles so that the gage sets on the angular side of the countersink, as opposed to a chamfer gage which sets on the top edge of the chamfer.

This gage directly reads the large diameter of the countersink in .002" or 0.05 mm increments. A set master ring is furnished with each gage for calibration and setting. Press the button on top of the indicator to firmly depress the gage head into the countersink. When the gage is removed, the indicator reading is held in place until the reset button is activated.

All ground surfaces are of hardened tool steel. Indicators are AGD design.

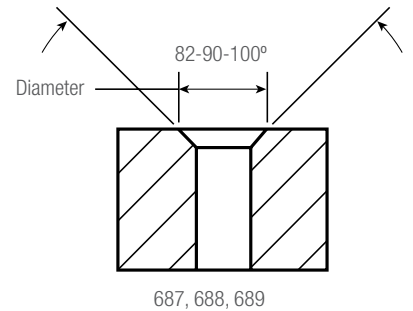

Inch Reading Countersink Gages

| 82° Angle | | 90° Angle | | 100° Angle | | Range |
|-----------|-------|-----------|-------|------------|-------|------------|
| Cat. No. | EDP | Cat. No. | EDP | Cat. No. | EDP | |
| 687-1Z | 63698 | 688-1Z | 63702 | 689-1Z | 63706 | .020-.170" |
| 687-2Z | 63699 | 688-2Z | 63703 | 689-2Z | 63707 | .160-.360" |
| 687-3Z | 63700 | 688-3Z | 63704 | 689-3Z | 63708 | .360-.560" |
| 687-4Z | 63701 | 688-4Z | 63705 | 689-4Z | 63709 | .560-.780" |

Millimeter Reading Countersink Gages with Yellow Dials

| 82° Angle | | 90° Angle | | 100° Angle | | Range |
|-----------|-------|-----------|-------|------------|-------|-------------|
| Cat. No. | EDP | Cat. No. | EDP | Cat. No. | EDP | |
| 687M-1Z | 65003 | 688M-1Z | 65007 | 689M-1Z | 65011 | 0.5-4.3mm |
| 687M-2Z | 65004 | 688M-2Z | 65008 | 689M-2Z | 65012 | 4-9mm |
| 687M-3Z | 65005 | 688M-3Z | 65009 | 689M-3Z | 65013 | 9-14.2mm |
| 687M-4Z | 65006 | 688M-4Z | 65010 | 689M-4Z | 65014 | 14.2-19.8mm |

Check Gage Stand for Chamfer, Countersink and Hole Gages

| Cat. No. | EDP | Description |
|----------|-------|---|
| 695 | 63875 | 8-3/16" H x 6" W x 4" D (212 x 150 x 100mm) Hold Downs - 5" (125mm) on Center - 1/4" (6.3mm) Holes |

Also available with electronic indicators. Please specify.



687-3Z Countersink Gage with 695 Check Stand with F2720-4IQ Electronic Indicator



SPECIAL FUNCTION INDICATORS

HOLE GAGES

690 HOLE GAGE

.010-.330"

690M HOLE GAGE

0.25-8.35MM

These hole gages will check hole diameters to .001" and 0.02mm. They are fast, accurate, easy to read and have a balanced design for easy one-hand operation.

The gage can be pressed down on a flat surface and checked so the size should read the same as the set number stamped on the back of the indicator. It can also be checked and set with an optional "setting master".

All ground surfaces are of hardened tool steel. Indicators are AGD design.

Holes that need to be accurately checked must have no chamfers or countersinks.



| Inch Reading Hole Gages | | | | |
|-------------------------|-------|------------------------|-------|------------|
| Gages | | Set Masters (Optional) | | |
| Cat. No. | EDP | Part No. | EDP | Range |
| 690-1Z | 63710 | PT23710-1 | 63879 | .010-.040" |
| 690-2Z | 63711 | PT23710-2 | 63880 | .030-.130" |
| 690-3Z | 63712 | PT23710-3 | 63881 | .130-.230" |
| 690-4Z | 63713 | PT23710-4 | 63882 | .230-.330" |

| Millimeter Reading Hole Gages with Yellow Dials | | | | |
|---|-------|------------------------|-------|-------------|
| Gages | | Set Masters (Optional) | | |
| Cat. No. | EDP | Part No. | EDP | Range |
| 690M-1Z | 63714 | PT23710-5 | 63883 | .25-1.00mm |
| 690M-2Z | 63715 | PT23710-6 | 63884 | .75-3.30mm |
| 690M-3Z | 63716 | PT23710-7 | 63885 | 3.30-5.85mm |
| 690M-4Z | 63717 | PT23710-8 | 63886 | 5.85-8.35mm |

| Check Gage Stand for Chamfer, Countersink and Hole Gages | | |
|--|-------|--|
| Cat. No. | EDP | Description |
| 695 | 63875 | 8-3/16" H x 6" W x 4" D (212 x 150 x 100mm) Hold Downs - 5" (125mm) on Center - 1/4" (6.3mm) Holes |

Also available with electronic indicators. Please specify.

170 DIAL SHEET GAGES

.150"

Measures the thickness of sheet materials like paper, cardboard, leather, plastics and metals. Raise the movable contact, insert the work, remove thumb, and spring pressure holds the work parallel with the contacts. Thickness is registered on the dial. By turning the knurled bezel, the dial may be moved to bring the hand to zero.

- Contact edges are radiused to prevent work from being marred or deflected
- The flat contact area measures 5/16" in diameter
- Black finish
- 1-1/8" throat depth
- Furnished in deluxe padded case

| 170 Dial Sheet Gages, Inch Reading | | | | |
|------------------------------------|-------|-------|------------|--------------|
| Cat. No. | EDP | Range | Graduation | Dial Reading |
| 170Z | 50647 | .150" | .001" | 0-100 |



SPECIAL FUNCTION INDICATORS

649 SPINDLE SQUARES™

The 649 Spindle Square™ offers accuracy, convenience and significant time saving with the common shop task of trammung the head of a vertical milling machine. This must be done regularly to ensure squariness and perpendicularity between the spindle and work surface.

The spindle square is easier to use and more precise than the traditional method of trammung with a dial test indicator.

USING THE SPINDLE SQUARE

After setting the spindle square indicators to "0" on a surface plate, place the Spindle Square™ into the collet of the milling machine and bring the head down to the table until both indicator needles have rotated approximately one full rotation.

The needles do not need to point in the same direction. Identical numerical readings, not the needle positions, indicate squareness.

To tram the milling machine, adjust the machine per normal procedures until both indicators read the same numerical value. After setting the X-axis, repeat the same procedure with the Y-axis.

FEATURES AND SPECIFICATIONS

- Fully assembled with two AGD Group 2 dial indicators
- Patented design
- Solid steel body construction with durable black oxide finish
- Ground gaging surface
- Approximately 4lbs with custom case
- 3/8" inch shank diameter
- 4" (100mm) between contact points
- Approximately 6-3/4" (172mm) wide and 5" (140mm) from the top of shank to the end of the contact points

| 649 Spindle Square | | | | |
|--------------------|-------|-------|------------|--------------|
| Cat. No. | EDP | Range | Graduation | Dial Reading |
| 649-1 | 52080 | .250" | .001" | 0-50-0 |
| 649-5 | 52081 | .125" | .0005" | 0-25-0 |
| 649-1M | 52082 | 2.5mm | 0.01mm | 0-50-0 |



SPECIAL FUNCTION INDICATORS

765A ELECTRONIC SNAP GAGE

0-1/2"/0-12.7MM

High quality, economical gage that is ideal for inspectors, purchasing agents, sales people and other who need to quickly measure materials up to 1/2" or 12.7mm thick.

- Balanced, compact design
- Simple, logical control buttons
- Easy-to-read LCD
- Single, long-life battery with easy access
- Light-weight aluminum frame
- Inch/millimeter conversion
- Zero at any position
- Manual ON/OFF, AUTO OFF
- Furnished in fitted plastic case



765A

765A* Electronic Snap Gage

| Cat. No. | EDP | Range | | Linear Accuracy | | Resolution | |
|----------|-------|-------|--------|-----------------|-------|------------|------|
| | | in | mm | in | mm | in | mm |
| 765A | 67659 | 0-1/2 | 0-12.7 | ±.0010 | ±0.02 | .0005 | 0.01 |

Accessories

| Part No. | EDP | Description |
|----------|-------|-----------------------------------|
| PT99492 | 65650 | Two Replacement Batteries, CR2032 |

* No output available on the 765A.

1010, 1010M DIAL INDICATOR POCKET GAGES

.375"/9MM

Handy pocket gage is approximately the size of a thin pocket watch. Ideal for inspectors, purchasing agents and sales people to check the size of materials up to 3/8" or 9mm thick. The gage fits naturally in the curve between the thumb and index finger. A slight pull on the serrated top plate raises the spindle.

- Throat depth ranges from 1/2" (12.7mm) down to 5/16" (8mm)
- Models are available with flat or rounded contacts as listed
- The diameter of both the flat or round contacts are 1/4" (6.3mm)
- Gage has a small count hand for recording each revolution of large hand
- Chrome plated case, unbreakable crystal dial cover
- Furnished in attractive, protective case

1010 Dial Indicator Pocket Gages, Inch Reading

| Cat. No. | EDP | Range | Graduation | Dial Reading | Contacts |
|----------|-------|-------|------------|--------------|----------|
| 1010Z | 53114 | .375" | .001" | 0-100 | Flat |
| 1010EZ | 53115 | .375" | .0005" | 0-50 | Flat |
| 1010RZ | 56067 | .275" | .001" | 0-100 | Round |

1010M Dial Indicator Pocket Gages, Millimeter Reading

| Cat. No. | EDP | Range | Graduation | Dial Reading | Contacts |
|----------|-------|-------|------------|--------------|----------|
| 1010MZ | 53116 | 9mm | 0.01mm | 0-100 | Flat |



1010Z



INDICATORS AND GAGES



SPECIAL FUNCTION INDICATORS

1015, 1015M PORTABLE DIAL THICKNESS GAGES

0-1" / 0-25MM

After inserting work between the measuring contacts, releasing the lever will cause the spindle to contact the work, giving an accurate size reading because measuring pressure is independent of the user. Indicators have jewel bearings and continuous dials. Models with balanced dials, other graduations and ranges are also available on special order. Electronic indicators can also be furnished. Throat depths include 2-1/2", 4", and 6". The contact edges are radiused to prevent the work from being marred or deflected. The flat contact area measures 1/4" (6.3mm) in diameter and is 1/8" (0.125mm) thick. Special contact sizes and shapes are available by request.



1015 Portable Dial Thickness Gages, Inch Reading

| Without Case | | Case Only | | Throat Depth | Range | Graduation | Dial Reading | Dial Indicator Model No. |
|--------------|-------|-----------|-------|--------------|-------|------------|--------------|--------------------------|
| Cat. No. | EDP | Cat. No. | EDP | | | | | |
| 1015A | 53119 | 1015AZZ | 55407 | 2-1/2" | 1/2" | .0005" | 0-50 | 1015A-431J |
| 1015B | 53121 | 1015BZZ | 55408 | | 1" | .001" | 0-100 | 1015B-441J |
| 1015A-4 | 67646 | | | 4" | 1/2" | .0005" | 0-50 | 1015A-431J |
| 1015B-4 | 67649 | | | | 1" | .001" | 0-100 | 1015B-441J |
| 1015A-6 | 67652 | | | 6" | 1/2" | .0005" | 0-50 | 1015A-431J |
| 1015B-6 | 67655 | | | | 1" | .001" | 0-100 | 1015B-441J |

1015M Portable Dial Thickness Gages, Millimeter Reading

| Without Case | | Case Only | | Throat Depth | Range | Graduation | Dial Reading | Dial Indicator Model No. |
|--------------|-------|-----------|-------|--------------|-------|------------|--------------|--------------------------|
| Cat. No. | EDP | Cat. No. | EDP | | | | | |
| 1015MA | 56131 | 1015AZZ | 55407 | 63mm | 10mm | 0.01mm | 0-100 | 1015MA-481J |
| 1015MB | 56133 | 1015BZZ | 55408 | | 25mm | | | 1015MB-881J |
| 1015MA-100 | 67647 | | | 100mm | 10mm | 0.01mm | 0-100 | 1015MA-481J |
| 1015MB-100 | 67650 | | | | 25mm | | | 1015MB-881J |
| 1015MA-150 | 67653 | | | 150mm | 10mm | 0.01mm | 0-100 | 1015MA-481J |
| 1015MB-150 | 67656 | | | | 25mm | | | 1015MB-881J |



SPECIAL FUNCTION INDICATORS

1150 DIAL INDICATOR SNAP GAGES

0-8"

These compact gages have rigid aluminum alloy frames protected from hand heat by insulating handles. They are used to gage outside diameters to an accuracy of .0001".

Dimensional variations are transmitted to the dial indicator through a linear friction-free transfer mechanism totally enclosed for protection against side thrust, foreign matter and coolants. Flat gaging contacts simplify measurement close to shoulders. The top sensitive contact may be reversed to present a spherical face to the work. An adjustable backstop simplifies centering the work.

The contacts and backstop are 5/16" diameter hardened tool steel, precision ground and lapped flat. The contacts are individually adjustable to a maximum 2" range and are locked in position by tightening parallel-lock clamps to maintain parallelism of faces. Both contacts are also keyed to maintain orientation of faces regardless of adjustment.

Plus or minus tolerances are read directly from the indicator since the dial face has a double row of graduations reading in opposite directions from zero, with "minus" graduations in red and "plus" in black. The indicator can be rotated 360° and locked in position to read from any angle, and a fine-adjusting screw provides for zero setting the hand. A guard protects the dial indicator when the gage is laid down.

A bench stand is available to convert the gage to a bench comparator. T1150 Dial Indicator Snap Gages also available with indicators other than those listed, a 717 Gage Amplifier and gaging head in place of the indicator, carbide faces on the contacts, special contact and backstop shapes and sizes, variable gaging pressure control, disc setting and other special masters, and larger ranges.

| 1150 Dial Indicator Snap Gages, Inch Reading | | | | | | |
|--|-------|------------------|----------------|--------------|-------|-------------|
| Without Stand | | | Dial Indicator | | | |
| Cat. No. | EDP | Range | Graduation | Dial Reading | Range | Model No. |
| 1150Z-2 | 53168 | 0-2" | .0001" | 10 - 10 | .040" | 81-111-1150 |
| 1150Z-4 | 53169 | 2-4" | | | | |
| 1150Z-6 | 53170 | 4-6" | | | | |
| 1150Z-8 | 53171 | 6-8" | | | | |
| Accessory for 1150 Dial Indicator Snap Gages | | | | | | |
| Cat. No. | EDP | Description | | | | |
| 1150 | 53172 | Bench Stand Only | | | | |

Gages furnished in case.

SPECIAL CONTACTS

Some of the many interchangeable anvil configurations designed to suit special applications.

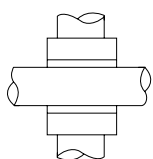

Wide Face up to 9/16" Square

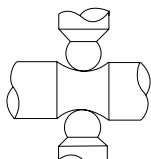

Ball or Roll

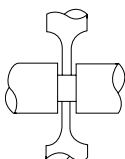

Blade Type

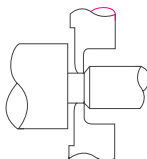

Offset

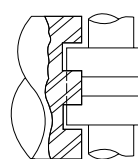

Offset for Face Groove

1150Z-2 mounted on
1150 Bench Stand



INDICATORS AND GAGES



1150Z-2 with F2720AD
Electronic Indicator



SPECIAL FUNCTION INDICATORS

1175, 1175M Dial Indicator Groove Gages

.375-6"/9.5-150MM

This lightweight gage is used for in-process or bench inspection of oil grooves, snap ring retainer grooves, "O" ring seat retainer grooves and similar internal recesses. It is also useful for checking bore dimensions and testing for taper, bell-mouth and out-of-roundness.

The movable, sensitive gaging contact has a 1/2" (12.7mm) retractable range and transfers the measurement through a linear, friction-free transfer mechanism to the dial indicator. The lower reference jaw is fixed and supports the entire weight of the gage and the operator's hands, thus preventing incorrect gaging pressure and false readings.

The reference jaw can be mounted in two positions on the range adjusting bar. The bar itself is also adjustable for greater or lesser range. A fine adjustment screw and a lock are also provided.

1175 and 1175M Dial Indicator Groove Gages

| Cat. No. | EDP | Range | Dial Indicator | | | |
|----------|-------|-----------|----------------|------------|---------|-------|
| | | | Model No. | Graduation | Reading | Range |
| 1175Z | 53173 | .375-6" | 81-136-1175 | .0005" | ±30 | .060" |
| 1175MZ | 65032 | 9.5-150mm | 81-181-1175 | 0.01mm | ±100 | 2.5mm |

1175 Dial Indicator Groove Gage Contact Sets

| Part No. | Upper | Lower | Contact Set | Will Enter Minimum Bore | | Maximum Groove I.D. | | Minimum-A Groove Depth | | Minimum-B Groove Width | |
|----------|---------|---------|-------------|-------------------------|------|---------------------|-----|------------------------|-----|------------------------|-----|
| | | | | in | mm | in | mm | in | mm | in | mm |
| PT30917 | PT30917 | PT30917 | Style 1-10 | .375" | 9.5 | 3.00" | 75 | .100" | 2.5 | .024" | 0.6 |
| PT30918 | PT30919 | PT30919 | Style 2-10 | .690" | 17.5 | 5.00" | 125 | .140" | 3.6 | .034" | 0.8 |
| PT30920 | PT30921 | PT30921 | Style 2-20 | 1.00" | 25 | 6.00" | 150 | .265" | 6.7 | .051" | 1.3 |

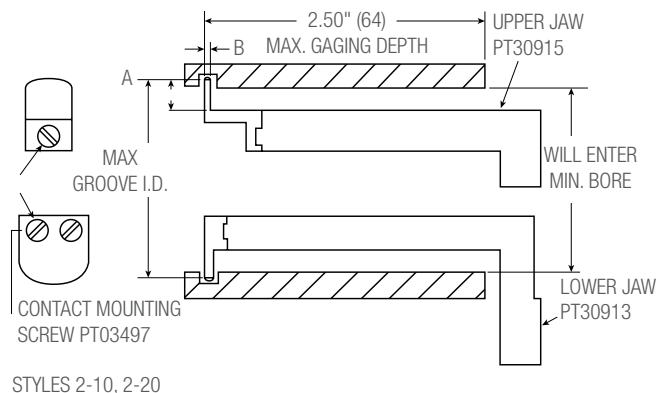
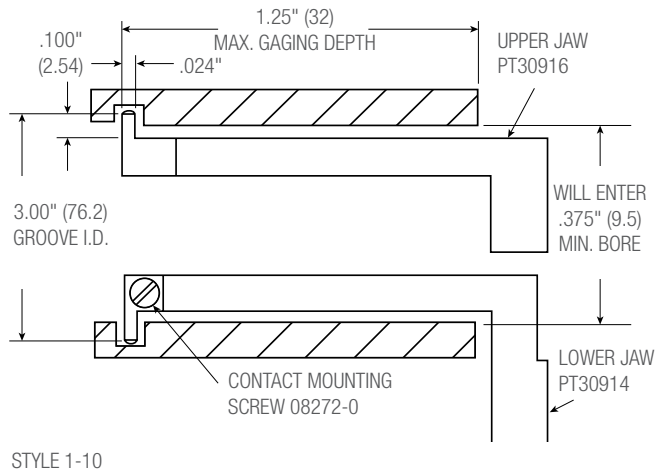

FEATURES

- Supplied with two sets of jaws, both readily interchangeable
- Three sets of contacts are furnished (Styles 1-10, 2-10, 2-20) that can be attached to the ends of the jaws without replacing the entire jaw. Contacts have flush ends so that grooves at the bottom of blind holes can be gaged. The contacts are hardened steel with a hard chrome finish for long life.
- Gage can be set with gage blocks or other methods such as micrometers, vernier calipers and ring gages
- Furnished with storage case

Special jaws for 4" and 6" (100mm and 150mm) gaging depths, a diameter range extension bar from 6-12" (150-300mm), dial indicators graduated in .001", or any special modification of gaging contacts and jaws, are also available by request through our Special Order Department.



SPECIAL FUNCTION INDICATORS

1017 OUTSIDE DIAL CALIPER GAGES

0-2"/0-50MM

These gages are designed for use in measuring castings, forgings and sheet metal work. Large clearances have been provided to reach over part configurations for easy measurement of small sections. The convenient retraction lever allows for one-hand operation and good gage control.

The dial indicator has a direct reading count hand. The contacts are cylindrical carbide for long wear life.



1017-4

| 1017 Outside Dial Caliper Gages | | | | |
|---------------------------------|-------|--------|------------|--------------|
| Cat. No. | EDP | Range | Graduation | Throat Depth |
| 1017-4 | 65091 | 0-2" | .001" | 4" |
| 1017-8 | 64959 | | | 8" |
| 1017M-100 | 64179 | 0-50mm | 0.02mm | 100mm |
| 1017M-200 | 64180 | | | 200mm |

1019, 1019M INTERNAL DIAL CALIPER GAGES

.400-1.4"/10-35MM

These indicating gages are ideal for obtaining fast, comparative I.D. measurements, especially in hard-to-reach locations. The user depresses the button on the indicator housing and releases, allowing the arms to make contact with the work.

- Makes convenient, accurate I.D. measurements
- Spring loaded design provides constant pressure and positive contact for reliable measurements
- Can be set with a micrometer or ring gage
- 3-1/4" arm length for ample reach
- Rotatable bezel for zero setting and bezel lock
- Jewel bearings
- .040" (1.016mm) dia. carbide ball measuring contacts



1019

1019M

| 1019 and 1019M Internal Dial Caliper Gages | | | |
|--|-------|-----------|---------------------------------|
| Cat. No. | EDP | Range | Description |
| 1019-1 | 66559 | .400-1.4" | .001" with Revolution Counter |
| 1019M-25 | 67120 | 10-35mm | 0.025mm with Revolution Counter |

697, 697M INSIDE DIAL GAGES

2-3/8-18"/61-458MM

These gages are used between two walls to check parallelism and also to take comparative measurements of internal diameters. There are ten rods and one extension furnished. The rods are marked to designate the approximate overall length of the gage. All measuring contacts are rounded. Tool can be set with a micrometer.

The indicator bezel is rotated to adjust the dial in relation to the hand and has a non-breakable crystal. The movement of the dial indicator is approximately 5/32" (4mm). Rods of different lengths can also be furnished on request.



697Z

| 697 and 697M Inside Dial Gages | | | | | |
|--------------------------------|-------|-----------|------------|--------------|----------------|
| Cat. No. | EDP | Range | Graduation | Dial Reading | One Revolution |
| 697Z | 52907 | 2-3/8-18" | .001" | 0-20-0 | .040" |
| 697MZ | 52908 | 61-458mm | 0.02mm | 0-50-0 | 1.0mm |



SPECIAL FUNCTION INDICATORS

668 SHAFT ALIGNMENT CLAMP SETS

The 668 Shaft Alignment Clamp is designed for fast, precise alignment of motors, pumps, compressors, etc. This system is capable of addressing radial and angular misalignment problems and can be set up within minutes.

668 Shaft Alignment Clamp Sets

| Cat. No. | EDP | Description |
|----------|-------|---|
| S668A | 67150 | 1 each: Chain Clamp, Extension Plate, Posts (5", 7-7/16", 9"), without Case |
| S668BZ | 67151 | 2 each: Chain Clamp, Extension Plate, Posts (5", 7-7/16", 9"), with Fitted Case |
| S668CZ | 67152 | 2 each: Chain Clamp, 196B5 Indicator, PT18724 Snug, Extension Plate, Posts (5", 7-7/16", 9"), with Fitted Case |
| S668DZ | 67153 | 2 each: Chain Clamp, 81-141J Indicator, 657Y Indicator Attachment, PT18724 Snug, Extension Plate, Posts (5", 7-7/16", 9"), with Fitted Case |
| 27984-0 | - | Extra Length Chain: 24" #35 ANSI Chain with Link |

668 Shaft Alignment Clamp

| Photo Key | Cat. No. | EDP | Individual Components |
|-----------|----------|-------|-------------------------------|
| A | 668 | 67155 | Chain Clamp Only |
| B | PT99529 | 67454 | Extension Plate Screw, Washer |
| C | PT27981 | 67302 | 5" Post |
| D | 657G | 52753 | 7-7/16" Post |
| E | PT27982 | 67303 | 9" Post |
| F | PT18724 | 50710 | Snug Complete |
| G | 657Y | 52765 | Indicator Attachment |

FEATURES

- Lightweight clamp design made of black anodized aluminum
- Rigid 3/8" diameter stainless steel indicator posts provided in three lengths (5", 7-7/16", and 9")
- Extension plate allows for added radial clearance
- Heavy-duty roller chain can accommodate up to a 7-1/2" diameter shaft
- Sets are available with either two 196B5 or 81-141J Indicators
- Excess roller chain can be secured to the side of the chain clamp
- A second shaft alignment clamp can be mounted across from the first clamp to act as a vertical "target" for face alignment

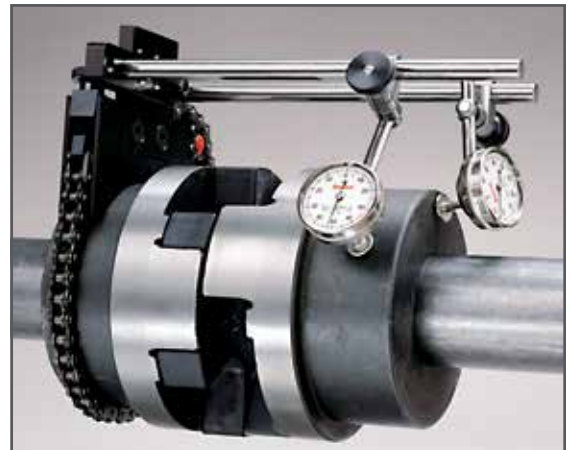
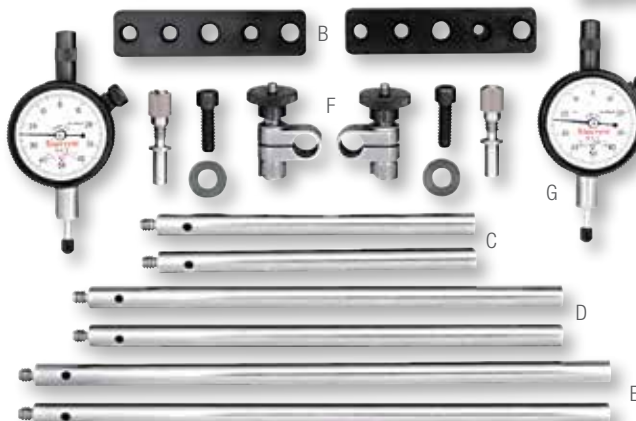

SPECIAL FUNCTION INDICATORS

696, 696M CRANKSHAFT DISTORTION DIAL/STRAIN GAGE

2-3/8-18"/61-458MM

Ideal gage for checking bearing alignment or shaft deflection without dismantling the engine. Also useful as a strain gage on engine frames. This inside measuring gage checks the distortion of crankshaft webs and bears a direct relation to existing misalignment or excessive bearing wear. Used on all diesel engine shafts and center crankshafts on any type of engine or compressor, the gage can also be applied as a strain gage on engine frames while the engine is operating. A comparison of readings taken at top and bottom positions indicates any misalignment of cylinder and frame which results in local over-stress and eventual cracking of the frame neck.

With a special spring tension in the dial indicator, the gage is self-sustaining in any position without sacrificing necessary rigidity, leaving the operator's hands free. Hardened and ground to a sharp point, conical contact points have an approximate 60° included angle, and will stay in place on 45° surfaces.



696 and 696M Crankshaft Distortion Dial/Strain Gages

| Cat. No. | EDP | Range | Dial Indicator | | | Description |
|----------|-------|---------------------------|----------------|--------------|----------------|--|
| | | | Graduation | Dial Reading | Range One Rev. | |
| 696Z | 52901 | 2-3/8-18" | .001" | 0-20-0 | .040" | Strain Gage with Balancing Attachment |
| 696MZ | 52902 | 61-458mm | 0.02mm | 0-50-0 | 1mm | Millimeter Strain Gage with Balancing Attachment |
| 696B | 52903 | Balancing Attachment Only | | | | |

Gage furnished with 10 rods, sharp points and balancing attachment in attractive, protective case.

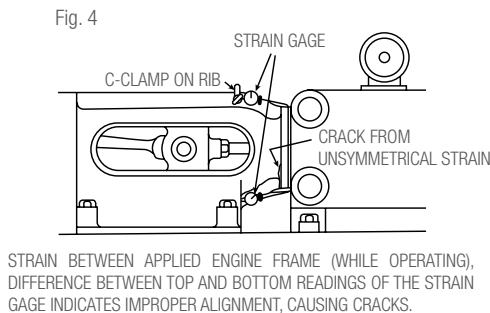
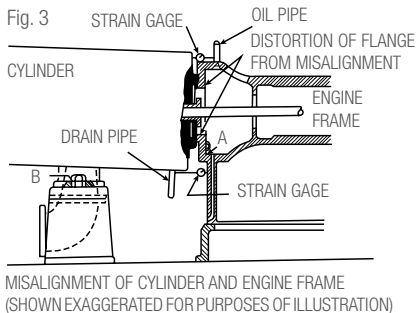
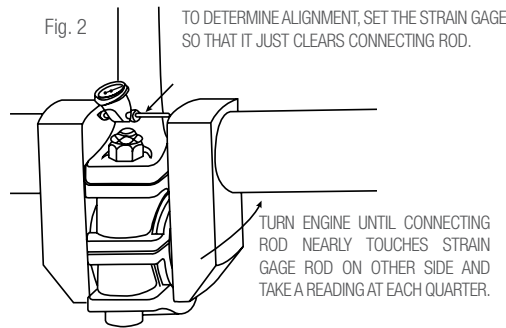
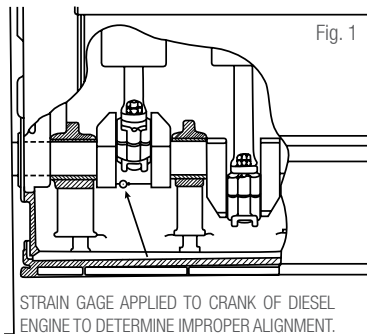

696B Balancing Attachment is furnished with the gage. For certain applications, like turning the crank under test with the gage in place, the attachment can be adjusted to maintain the face of the indicator upward or in desired position. To install on a strain gage in use, remove the knurled clamping nut, then the doweled plate or end strap at either end by the screw. The unit is then positioned over the hubs on two sides of the indicator head. A spring plunger provides the friction that holds the balance in proper relation to position. The parts are nickel plated.

The dial indicator movement is approximately 5/32" (4mm) and with rods and extension, provides a range from 2 3/8-18" or 61-458mm. There are 10 rods and one extension furnished. Rods are marked to designate the approximate overall length of the gage. Indicator has a movable bezel to adjust the dial in relation to the hand and a non-breakable crystal.

Designed in collaboration with Hartford Steam Boiler Inspection and Insurance Company. It was known as the Hartford Steam Boiler Engine Strain Gage and is used by their inspectors to check the distortion of engine shafts and frames.



696B Balancing Attachment



SPECIAL FUNCTION INDICATORS

452 CYLINDER GAGES

2-1/2–9"

These convenient, easy-to-use gages are used to determine taper and out-of-roundness of bores, offering a quick and accurate way to show your customer whether new rings or reconditioning is necessary.

The ranges are achieved by the use of two measuring contact rods. The gage is easily and accurately set to a micrometer.

FEATURES:

- Dial is graduated to show plus or minus
- Bezel may be rotated for zero setting
- Sled is hardened and ground for long, accurate life and has two long-line contacts in constant alignment with the cylinder wall. These reference points are spring loaded, making the gage self-centering and non-collapsible.
- The locking screw (stem protruding above the dial) clamps the contact points in position for measurement with a micrometer
- The handle can be locked in any perpendicular or angular position and may also be transformed by a slight turn into a toggle joint with a wide sweep
- Extra handles may be ordered to make a long extension

452 Cylinder Gages

| Cat. No. | EDP | Range | Graduation | Dial Reading | One Rev. |
|----------|-------|----------|------------|--------------|----------|
| 452B | 52339 | 2-1/2–6" | .001" | 0-100 | .100" |
| 452B-9 | 52341 | 2-1/2–9" | | | |

Accessories

| Cat. No. | EDP | Length | Description |
|----------|-------|--------|--------------------------------------|
| PT06722 | 72275 | 8-5/8" | Handle Extension for 452B and 452B-9 |

Height from contact points to top of handle is 10" (250mm).

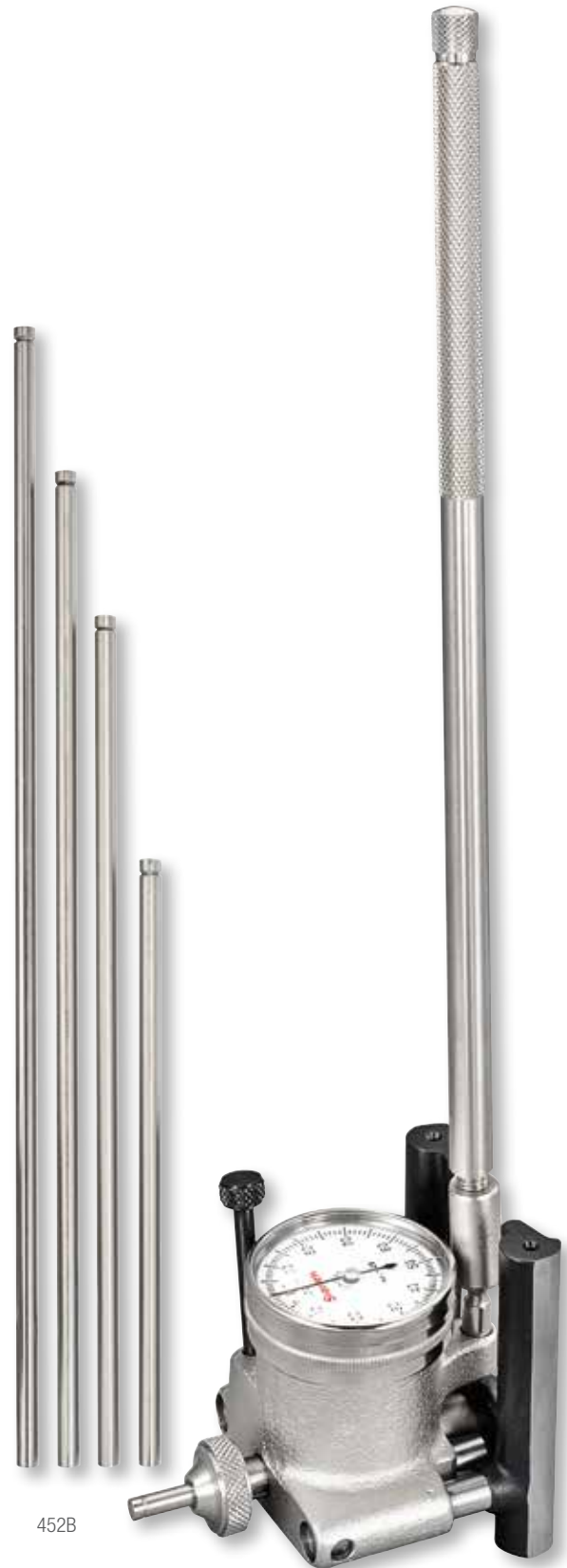



DIAL INDICATOR DIAMETER GAGES

These gages measure both outside and inside diameters by comparing dimensions to gage blocks or an adjustable setting master. Each gage consists of a strong rectangular box beam with a sensitive gaging contact at one end and a reference gaging contact at the other.

- All of the diameter gages have these features:
- The sensitive contact transfers dimensions to the dial indicator through a linear friction-free mechanism
- There are two gage feet at the reference end of the gage and one foot at the sensitive end of the gage to set the gage on the work and align the contacts
- Gage depth is set by adjusting the gage feet up or down
- A lever-actuated reverse mechanism loads the gage for either inside or outside diameter measurements
- The gage contacts are easily changed to I.D. or O.D. gaging by turning them end for end
- Unless otherwise specified, the dial indicator sent with the gage reads in .0005" increments with a total range of $\pm .030$ ". The dial has a double row of graduations reading in opposite directions – minus in red and plus in black

On the following pages we list our standard line but to suit other needs we also can furnish the following:

1. Any length that is required
2. Any dial indicator with inch or millimeter reading
3. 717 Electronic Gage Amplifier and Gaging Head in place of the indicator
4. Electronic indicators can also be furnished on any of these gages except the 1102
5. Special contact shapes
6. Gaging contacts with more depth



INDICATOR DIAMETER GAGES



1102, 1102M Dial Indicator Diameter Gages

1-12"/25-300MM

This is a light, easy-to-handle gage that is a workhorse in its range. Approximate weight is 1lb, 12oz. (0.8kg). The gaging depth can be set within a range of 0-1" (0-25mm) by adjusting the rest foot. Dial indicators are the 81-136-623 Inch Reading (.0005") or 81-181-623 Millimeter Reading (0.01mm) models.

The gage should be checked against our 1127 Master for a precise reference standard during production gaging (See the following pages). Also available on request with .0001" or 0.002mm graduations.

1102 and 1102M Dial Indicator Diameter Gages

| Cat. No. | EDP | Length Range | Height Adjustment |
|----------|-------|--------------------------|-------------------|
| 1102 | 56134 | 1-12" (.0005" Indicator) | 0-1" |
| 1102-1 | 69004 | 1-12" (.0001" Indicator) | 0-1" |
| 1102M | 65020 | 25-300mm | 0-25mm |

Case for 1102 and 1102M Dial Indicator Diameter Gages

| Cat. No. | EDP | Description |
|----------|-------|--|
| 1102ZZ | 56136 | Storage Case to Hold Both Gage and 1127 Master |

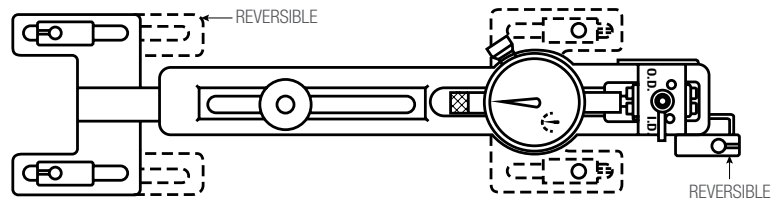

1102 and 1102M Dial Indicator Diameter Gages

| Photo Key | Description |
|-----------|---|
| A | Range Lock Screw |
| B | I.D.-O.D. Preload Reversing Mechanism Lever |
| C | Rest Foot |
| D | Reference Contact |
| E | Sensitive Contact |

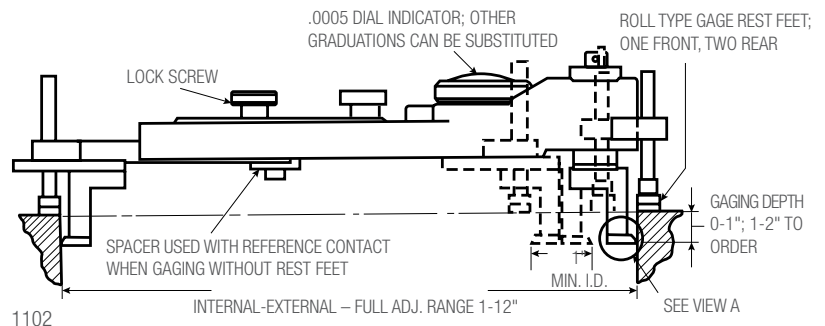

STANDARD CONTACTS FURNISHED WITH GAGE

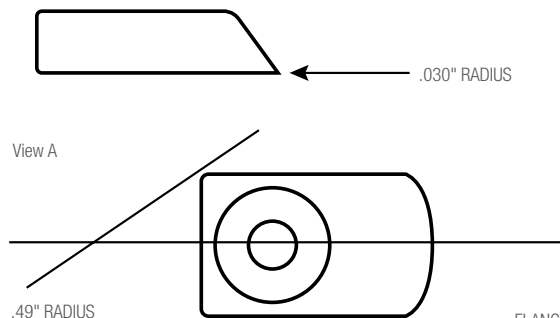

SPECIAL CONTACTS DESIGNED TO ORDER

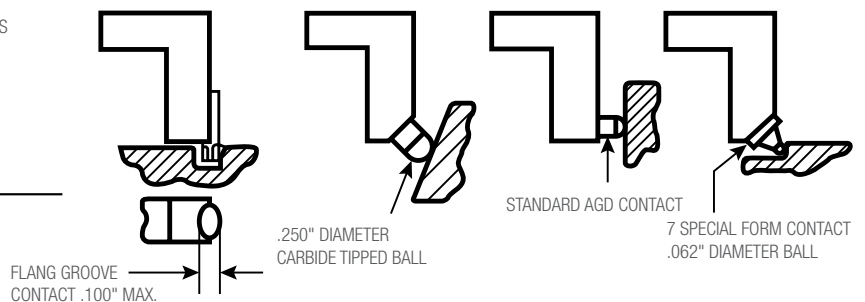

INDICATOR DIAMETER GAGES

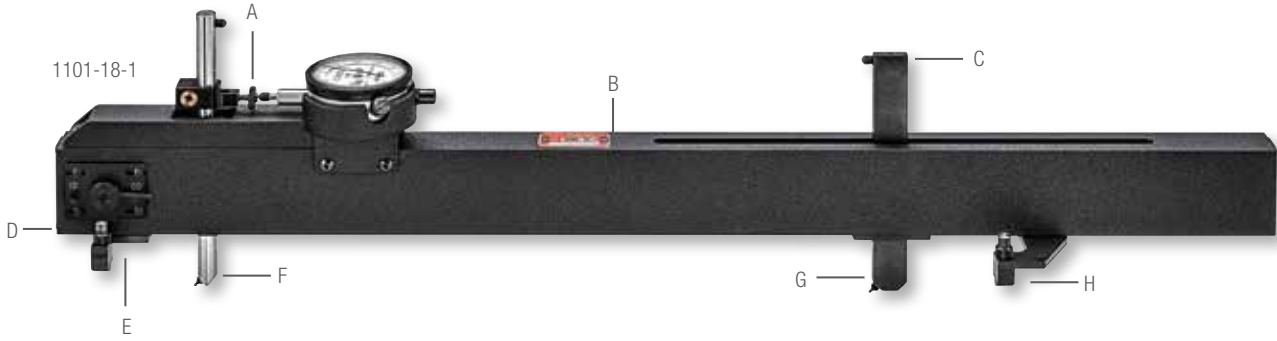

1101, 1101M DIAL INDICATOR DIAMETER GAGES

12-60"/300-1500MM

These gages allow for measurement beyond the size range of our 1102 models. Each gage adjusts a full 6" or 150mm. The contact carriers are vertically adjustable to handle various work depth. Special contacts are available.

This tool has dowel (line) contacts at one end of the gage feet, and a button (point) contact gage at the other end of the feet. These can be reversed as needed and the gaging depth can be set within a range of 2-3/4" or 70mm.

This gage should be checked against our 1126 Master for a precise reference standard during production gaging (See the following pages).

| 1101 and 1101M Dial Indicator Diameter Gages | |
|--|--|
| Photo | Description |
| A | Dial Indicator Fine-Adjusting Screw |
| B | Beam – Rectangular Box Section |
| C | Contact for Added Applications |
| D | I.D.-O.D. Preload Reversing Mechanism Lever |
| E | Combination Dowel/Button Rest Feet |
| F | Sensitive Contact |
| G | Reference Contact |
| H | Mounting Plate with Combination Dowel and Button Rest Feet |

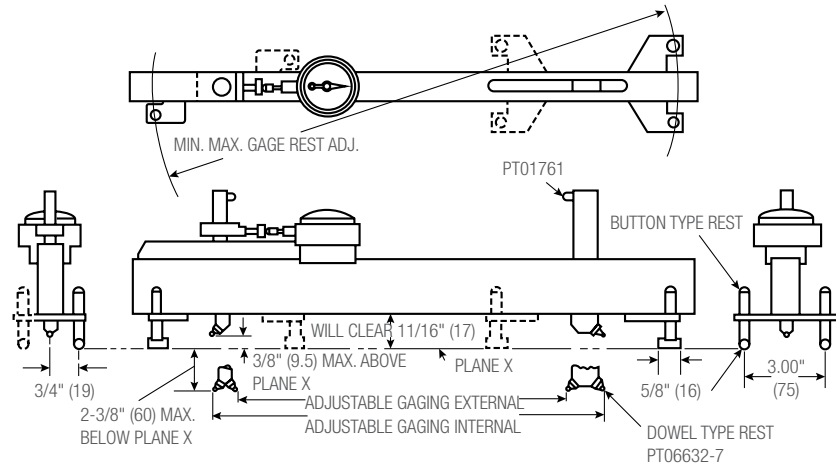

| 1101 and 1101M Dial Indicator Diameter Gages | | | | | | | | | |
|--|-----------|-----------------------------------|-------|--|-------|-----------------------------------|-------|---|-------|
| Length | | Inch Reading - .0005" Graduations | | Millimeter Reading - .01mm Graduations | | Inch Reading - .0001" Graduations | | Millimeter Reading - .002mm Graduations | |
| in | mm | Cat. No. | EDP | Cat. No. | EDP | Cat. No. | EDP | Cat. No. | EDP |
| 12-18 | 300-450 | 1101-18 | 53144 | 1101M-450 | 65015 | 1101-18-1 | 69005 | 1101M-450-2 | 69021 |
| 18-24 | 450-600 | 1101-24 | 53146 | 1101M-600 | 65016 | 1101-24-1 | 69006 | 1101M-600-2 | 69022 |
| 24-30 | 600-750 | 1101-30 | 53148 | 1101M-750 | 65017 | 1101-30-1 | 69007 | 1101M-750-2 | 69023 |
| 30-36 | 750-900 | 1101-36 | 53150 | 1101M-900 | 65018 | 1101-36-1 | 69008 | 1101M-900-2 | 69024 |
| 36-42 | 900-1050 | 1101-42 | 53152 | 1101M-1050 | 65019 | 1101-42-1 | 69009 | 1101M-1050-2 | 69025 |
| 42-48 | 1050-1200 | 1101-48 | 53154 | 1101M-1200 | 65021 | 1101-48-1 | 69010 | 1101M-1200-2 | 69026 |
| 48-54 | 1200-1350 | 1101-54 | 53156 | 1101M-1350 | 65022 | 1101-54-1 | 69011 | 1101M-1350-2 | 69027 |
| 54-60 | 1350-1500 | 1101-60 | 53158 | 1101M-1500 | 65023 | 1101-60-1 | 69012 | 1101M-1500-2 | 69028 |
| Gaging Contact Range: | | ±.050" | | ±1.3mm | | ±.050" | | ±1.3mm | |

Sent without case unless otherwise ordered. To order case, specify the Catalog and "ZZ" (For example: 1101ZZ-18).



INDICATOR DIAMETER GAGES



1100, 1100M Heavy-Duty Dial Indicator Diameter Gages

12-60"/300-1500MM

These gages combine heavy-duty construction features with adaptability for a wide range of internal and external measurements. The adjustable dowel rest legs ride on slotted mounting plates for horizontal adjustment. Each of the legs are vertically adjustable to obtain the proper rest position on the work and correct alignment on the gaging contacts. 2" or 50 mm range is the vertical adjustment.

The gaging contacts are radiused but may be modified by request to suit special gaging conditions.

The indicator and its housing can be rotated through to 360° so that the indicator may be read at the most convenient angle. The gage should be checked against our 1126 Master for a precise reference standard during production gaging (See the following pages).

1100 and 1100M Heavy-Duty Dial Indicator Diameter Gages

| Photo Key | Description |
|-----------|---|
| A | I.D.-O.D. Preload Reversing Mechanism Lever |
| B | Tamper Proof Dial Indicator Fine-Adjust Screw |
| C | Beam – Rectangular Box Section |
| D, E | Adjustable Dowel Rest Leg |
| F, K | Dowel Rest |
| G | Sensitive Contact |
| H | Slotted Rest Leg Mounting Plate |
| I | Reference Contact |
| J | Reference Contact Carrier |

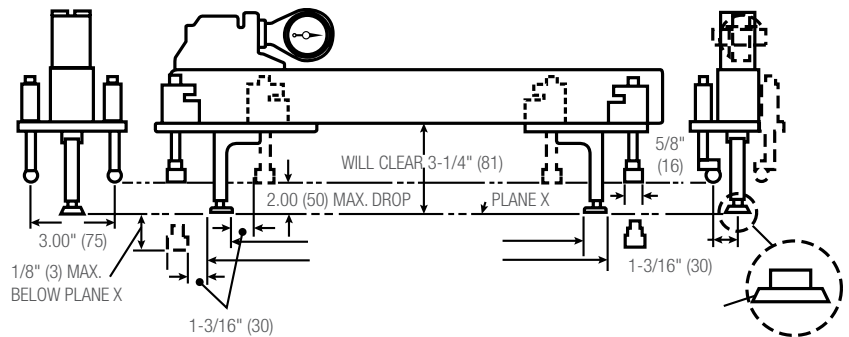

1101 and 1101M Dial Indicator Diameter Gages

| Length in | mm | Inch Reading - .0005" Graduations | | Millimeter Reading - .01mm Graduations | | Inch Reading - .0001" Graduations | | Millimeter Reading - .002mm Graduations | |
|------------------------------|-----------|-----------------------------------|-------|--|-------|-----------------------------------|-------|---|-------|
| | | Cat. No. | EDP | Cat. No. | EDP | Cat. No. | EDP | Cat. No. | EDP |
| 12-18 | 300-450 | 1101-18 | 53144 | 1101M-450 | 65015 | 1101-18-1 | 69005 | 1101M-450-2 | 69021 |
| 18-24 | 450-600 | 1101-24 | 53146 | 1101M-600 | 65016 | 1101-24-1 | 69006 | 1101M-600-2 | 69022 |
| 24-30 | 600-750 | 1101-30 | 53148 | 1101M-750 | 65017 | 1101-30-1 | 69007 | 1101M-750-2 | 69023 |
| 30-36 | 750-900 | 1101-36 | 53150 | 1101M-900 | 65018 | 1101-36-1 | 69008 | 1101M-900-2 | 69024 |
| 36-42 | 900-1050 | 1101-42 | 53152 | 1101M-1050 | 65019 | 1101-42-1 | 69009 | 1101M-1050-2 | 69025 |
| 42-48 | 1050-1200 | 1101-48 | 53154 | 1101M-1200 | 65021 | 1101-48-1 | 69010 | 1101M-1200-2 | 69026 |
| 48-54 | 1200-1350 | 1101-54 | 53156 | 1101M-1350 | 65022 | 1101-54-1 | 69011 | 1101M-1350-2 | 69027 |
| 54-60 | 1350-1500 | 1101-60 | 53158 | 1101M-1500 | 65023 | 1101-60-1 | 69012 | 1101M-1500-2 | 69028 |
| Gaging Contact Range: | | ±.050" | | ±1.3mm | | ±.050" | | ±1.3mm | |

Sent without case unless otherwise ordered. To order case, specify the Catalog and "ZZ" (For example: 1101ZZ-18).



INDICATOR DIAMETER GAGES

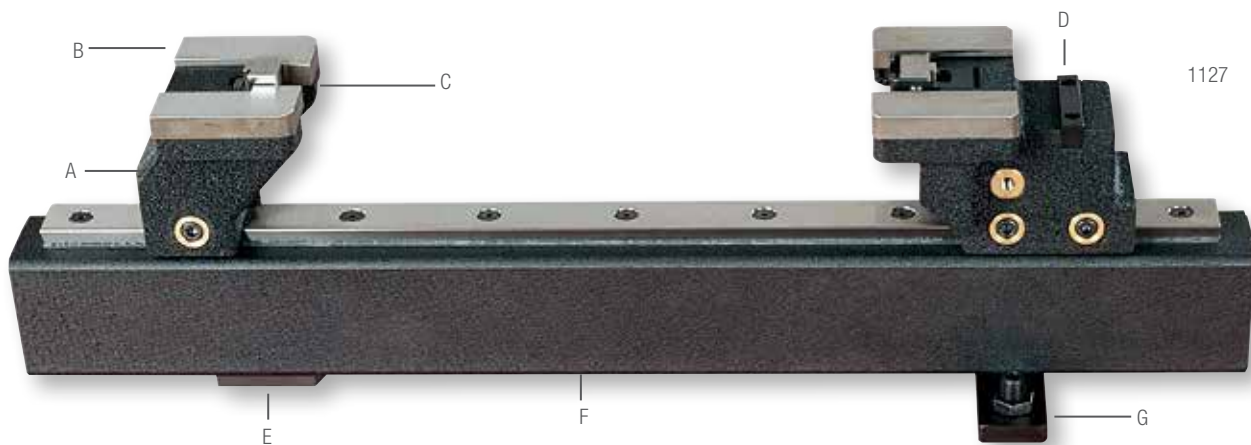

1127 INTERNAL-EXTERNAL ADJUSTABLE SETTING MASTER FOR STARRETT 1102 DIAMETER GAGES

EDP 56135

This set master is used with our 1102 Diameter Gages. The internal adjustment range is 1–12" (25-300mm) and external adjustment is 5-1/4–12" (133-300mm). Storage case is available to hold both the gage and master (Catalog 1102ZZ, EDP 56136).

1127 Internal-External Adjustable Setting Master for Starrett 1102 Diameter Gages

| Photo Key | Description |
|-----------|--------------------------------|
| A | Sensitive Head |
| B | Hardened Rest Platen |
| C | Anvil |
| D | Reference Head |
| E | Fixed Single Point Button Rest |
| F | Beam – Rectangular Box Section |
| G | Leveling Screws (2) |

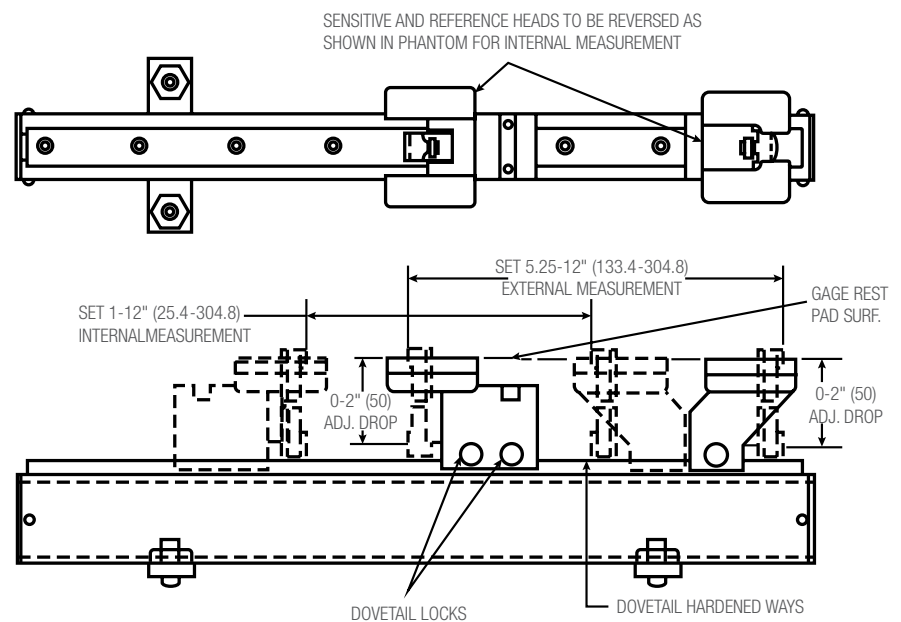

SETTING MASTERS FOR DIAL INDICATOR DIAMETER GAGES

These setting masters are used to check and reset diameter gages under production gaging conditions. Each master consists of a rigid box beam with reference and sensitive heads which are individually adjustable along dovetail ways.

A platen on each head locates the diameter gage from its feet. The position of the gage contacts is matched by the anvils on the masters which are vertically adjustable. The reference head anvil has a fine adjustment for final settings, plus a restrictor to help position the gage in the master.

Both heads can be reversed for I.D. or O.D. settings. Each master has a fixed single point rest and two leveling screws which provide a three-point suspension. All contact and working surfaces are hardened and ground.

The setting procedure is as follows: set the diameter gage precisely to gage blocks or height gages. Then, using the diameter gage, set the master which can then be used as a precise reference standard for the diameter gage during production gaging.



INDICATOR DIAMETER GAGES



1126 INTERNAL-EXTERNAL ADJUSTABLE SETTING MASTERS FOR STARRETT 1100 AND 1101 DIAMETER GAGES

12-60"/300-1500MM

These set masters are used to check and reset Starrett 1100 and 1101 Diameter Gages under production gaging conditions. The range is from 12-60" or 300-1500mm.

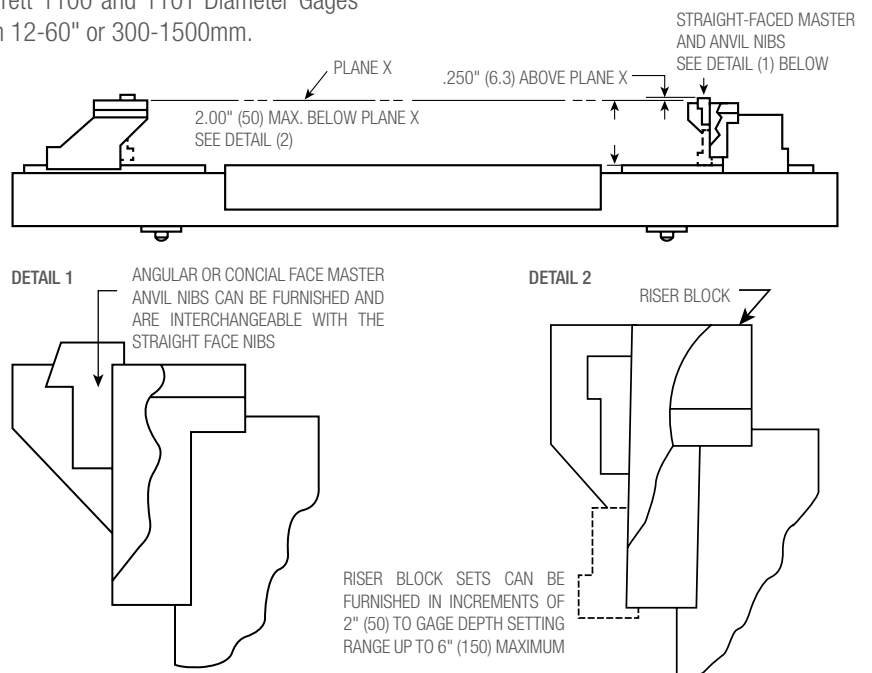

1126 Internal-External Adjustable Setting Masters for Starrett 1100 and 1101 Diameter Gages

| Photo Key | Description |
|-----------|--------------------------------|
| A | Sensitive Head |
| B | Hardened Rest Platen |
| C | Anvil |
| D | Reference Head |
| E | Leveling Screws (2) |
| F | Beam – Rectangular Box Section |
| G | Fixed Single Point Button Rest |

ANGULAR OR CONICAL NIBS AND RISER BLOCKS QUOTED UPON REQUEST

1126 Internal-External Adjustable Setting Masters for Starrett 1100 and 1101 Diameter Gages

| Cat. No. | EDP | Case Only Cat. No. | Length Range | For Use With Diameter Gage Nos. | | | | | |
|----------|-------|--------------------|--------------|---------------------------------|---------|------------|---------|------------|----|
| | | | | in | mm | in | mm | in | mm |
| 1126-18 | 53160 | 1126ZZ-18 | 12-18 | 300-450 | 1100-18 | 1100M-450 | 1101-18 | 1101M-450 | |
| 1126-24 | 53161 | 1126ZZ-24 | 18-24 | 450-600 | 1100-24 | 1100M-600 | 1101-24 | 1101M-600 | |
| 1126-30 | 53162 | 1126ZZ-30 | 24-30 | 600-750 | 1100-30 | 1100M-750 | 1101-30 | 1101M-750 | |
| 1126-36 | 53163 | 1126ZZ-36 | 30-36 | 750-900 | 1100-36 | 1100M-900 | 1101-36 | 1101M-900 | |
| 1126-42 | 53164 | 1126ZZ-42 | 36-42 | 900-1050 | 1100-42 | 1100M-1050 | 1101-42 | 1101M-1050 | |
| 1126-48 | 53165 | 1126ZZ-48 | 42-48 | 1050-1200 | 1100-48 | 1100M-1200 | 1101-48 | 1101M-1200 | |
| 1126-54 | 53166 | 1126ZZ-54 | 48-54 | 1200-1350 | 1100-54 | 1100M-1350 | 1101-54 | 1101M-1350 | |
| 1126-60 | 53167 | 1126ZZ-60 | 54-60 | 1350-1500 | 1100-60 | 1100M-1500 | 1101-60 | 1101M-1500 | |

Setting masters for larger diameters are also available by request – priced on the application.

In addition to the products detailed in this section, we have made many other special function gages to suit a wide variety of our customers' specific requirements.

If you have a special application, we invite you to submit your drawings and specifications to our Special Order Department at 121 Crescent Street, Athol, MA 01331, USA. We will be happy to provide a prompt quotation.





BORE GAGES

NEW!

ELECTRONIC BORE GAGES



781BXT AccuBore® ELECTRONIC BORE GAGES WITH OUTPUT

.080"-8"/2-200MM

AccuBore is a high-quality, trigger-activated, two-point and three-point contact bore gaging system with extended range. Its convenient single-hand operation provides speed and control. Simply squeeze the trigger, insert the gage into the bore and release the trigger for an instant reading from the large, easy-to-read digital display.

What makes AccuBore superior to other gages are features like the mechanically-driven parallel anvils which extend simultaneously, establishing a more true alignment to the axis of the bore. This provides consistent pressure, resulting in more accurate readings than models with spring-driven contacts which are subject to pressure variations.

Speed and convenience are further enhanced by the repositionable AccuBore® indicator, which may be swiveled and rotated for left, right hand or even vertical viewing. The gage also features a set of "Go/No-Go" lights in the readout display that quickly indicates whether a bore measurement is within a preset tolerance.

FEATURES

- Bluetooth® capability
- Single-hand operation with right- and left-hand viewing flexibility
- Large, easy-to-read display
- Enhanced wear life with carbide-faced contacts – available from 1/2" to 8"
- Convenient "Go/No-Go" tolerance indicator lights
- True alignment with mechanically-driven parallel anvils
- Resolution .00005" (0.001mm)
- Accuracy of up to .00015" (.004mm)
- Push button inch/metric conversion
- Preset and preset recall
- Hold, max/min and zeroing capabilities
- Blind bore measurement is standard for .50" (12.7mm) and above
- Specialized heads available for thread, groove and other non-standard measurements on request
- Output capability for Statistical Process Control (SPC) analysis. Download data via USB to a PC or RS232 connection.



781BXTZ-138

BORE GAGE MEASURING TIPS

Whether to use a two-point or three-point contact measuring tool is usually a matter of preference, but there are some differences.

A two-point contact rod-type inside micrometer is usually lighter, easier to handle, and more versatile over long ranges from approximately 6-107" (150-2700mm).

Any two-point contact micrometer, regardless of range, can probe a hole better to find the geometry of that hole than a three-point contact.

Most three-point contact tools have setting rings to ensure accuracy. If you desire very close tolerance work with two-point contact inside micrometers, it is recommended that they be set to a ring gage or to an outside micrometer.

A three-point contact micrometer has an advantage in that it can be seated in position more quickly than a two-point contact tool.

Usually these tools can also be read to a finer accuracy. The three-point tool will tell the maximum true diameter that can enter the hole a little faster than a two-point contact tool.

Micrometer heads used in these tools are accurate to $\pm .0001$ " or 0.002mm, but overall accuracy on tools that add rods is dependent on good practice and technique.

To ensure accuracy, these practices should be followed:

- Always make sure that there are no specks of dirt between the clamping surfaces of the rods and micrometer heads
- Tighten all rods uniformly, not too tightly, not too loosely, but a fairly firm assembly
- Assembling long sections should be done vertically or, with support, horizontally
- Because temperature can affect long rods used in these tools, they should be assembled in the same environment in which they will be used



BORE GAGES



Output jack enables collection of measurement data for SPC analysis



AccuBore XT's indicator can be rotated, allowing easy reading from either the right or left hand, or when accessing difficult to reach holes



Sets include gage, contacts, setting rings, instructions, certificate of calibration and a 3v lithium battery in a protective carrying case

781BXT AccuBore Electronic Bore Gages with Output – 2-Point Contact (.080-.250" (2-6mm) Range)

| Cat. No. | EDP | Range | | Accuracy | | Approx Meas. Depth | | Ring Diameter | |
|-------------|-------|-----------|-------|----------|------|--------------------|----|---------------|------|
| | | in | mm | in | mm | in | mm | in | mm |
| 781BXTZ-100 | 73017 | .080-.100 | 2-2.5 | .00015 | .004 | 3/8 | 9 | .100 | 2.54 |
| 781BXTZ-120 | 73016 | .100-.120 | 2.5-3 | .00015 | .004 | 1/2 | 12 | .160 | 4.06 |
| 781BXTZ-160 | 73014 | .120-.160 | 3-4 | .00015 | .004 | 3/4 | 18 | .200 | 5.08 |
| 781BXTZ-200 | 73012 | .160-.200 | 4-5 | .00015 | .004 | 3/4 | 18 | .200 | 5.08 |
| 781BXTZ-250 | 73011 | .200-.250 | 5-6 | .00015 | .004 | 3/4 | 18 | .200 | 5.08 |

781BXT AccuBore® Electronic Bore Gages with Output – 3-Point Contact (1/4-8" (6-200mm) Range) – Fixed Anvils

| Cat. No. | EDP | Range | | Accuracy | | Approx Meas. Depth | | Ring Diameter | |
|-------------|-------|-------------|---------|----------|------|--------------------|-----|---------------|--------|
| | | in | mm | in | mm | in | mm | in | mm |
| 781BXTZ-312 | 73009 | 1/4-5/16 | 6-8 | .00015 | .004 | 2-1/4 | 58 | .3125 | 7.94 |
| 781BXTZ-375 | 73007 | 5/16-3/8 | 8-10 | .00015 | .004 | 2-1/4 | 58 | .500 | 12.7 |
| 781BXTZ-500 | 73004 | 3/8-1/2 | 10-12.5 | .00015 | .004 | 2-3/8 | 62 | .750 | 19.05 |
| 781BXTZ-625 | 73002 | 1/2-5/8 | 12.5-16 | .00015 | .004 | 2-5/8 | 66 | .750 | 19.05 |
| 781BXTZ-750 | 73000 | 5/8-3/4 | 16-20 | .00015 | .004 | 3-1/16 | 80 | 1.375 | 34.93 |
| 781BXTZ-1 | 73018 | 3/4-1 | 20-25 | .00015 | .004 | 3-1/16 | 80 | 2.625 | 65.68 |
| 781BXTZ-138 | 73015 | 1-1-3/8 | 25-35 | .00015 | .004 | 3-3/8 | 85 | 3.250 | 82.55 |
| 781BXTZ-2 | 73013 | 1-3/8-2 | 35-50 | .00015 | .004 | 4 | 100 | 5.0 | 127.00 |
| 781BXTZ-258 | 73010 | 2-2-5/8 | 50-65 | .0002 | .005 | 4 | 100 | 5.0 | 127.00 |
| 781BXTZ-314 | 73008 | 2-5/8-3-1/4 | 65-80 | .0002 | .005 | 4 | 100 | 5.0 | 127.00 |
| 781BXTZ-4 | 73006 | 3-1/4-4 | 80-100 | .0002 | .005 | 4 | 100 | 5.0 | 127.00 |
| 781BXTZ-5 | 73005 | 4-5 | 100-125 | .00025 | .006 | 4 | 100 | 5.0 | 127.00 |
| 781BXTZ-6 | 73003 | 5-6 | 125-150 | .00025 | .006 | 4 | 100 | 5.0 | 127.00 |
| 781BXTZ-7 | 73001 | 6-7 | 150-175 | .0003 | .007 | 4 | 100 | 7.0 | 177.80 |
| 781BXTZ-8 | 72999 | 7-8 | 175-200 | .0003 | .007 | 4 | 100 | 7.0 | 177.80 |

Pistol Grip Gage Only with Indicator*

| Cat. No. | EDP | Range | |
|--------------|-------|-----------|---------|
| | | in | mm |
| 781BXTP-250 | 73021 | .080-.250 | 2-6 |
| 781BXTP-750 | 73019 | 1/4-3/4 | 6-20 |
| 781BXTP-4 | 73020 | 3/4-4 | 20-100 |
| 781BXTP-12** | 73022 | 4-8 | 100-200 |

Larger sizes available on special order.

Gages are also available with dial indicators on special order.

* Does not include heads, rings, etc.

** Heads above 8" available on special order.



ELECTRONIC BORE GAGES

781BXT AccuBore® ELECTRONIC BORE GAGES

See specifications on previous pages

781BXT AccuBore Electronic Bore Gage Set – 2-Point Contact (.080-.250" [2-6 mm] Range)

| Cat. No. | EDP | Range in | mm | Number of Heads | Number of Rings |
|-----------|-------|-----------|-----|-----------------|-----------------|
| S781BXTBZ | 72998 | .080-.250 | 2-6 | 5 | 3 |

781BXT AccuBore Electronic Bore Gage Sets –3-Point Contact (.250-8" [6-200mm] Range – Fixed Anvils)

| Cat. No. | EDP | Range in | mm | Number of Heads | Number of Rings |
|-----------|-------|-----------|---------|-----------------|-----------------|
| S781BXTCZ | 72997 | .250-.375 | 6-10 | 2 | 1 |
| S781BXTHZ | 72992 | .250-.750 | 6-20 | 5 | 3 |
| S781BXTDZ | 72996 | .375-.750 | 10-20 | 3 | 2 |
| S781BXTFZ | 72994 | .750-2.00 | 20-50 | 3 | 3 |
| S781BXTJZ | 72991 | .750-4.00 | 20-100 | 6 | 4 |
| S781BXTKZ | 72990 | 2.00-4.00 | 50-100 | 3 | 2 |
| S781BXTGZ | 72993 | 4.00-6.00 | 100-150 | 2 | 1 |
| S781BXTLZ | 72989 | 4.00-8.00 | 100-200 | 4 | 4 |
| S781BXTLZ | 72989 | 6.00-8.00 | 150-200 | 2 | 1 |

Larger sizes available on special order.
Gages are also available with dial indicators on special order.

Accessories for 781BXT Electronic Internal Micrometers

| Part No. | EDP | Description | Required for Initial Bluetooth® Connection | 1 Device | > 1 Devices |
|----------|-------|--|--|----------|-------------|
| PT61055 | 72941 | 770B Output Cable to USB | | | |
| PT61057 | 72942 | 770B Output Cable to USB with Footswitch | | | |
| | | Free VMUX Software - 1 channel; visit starrett.com | x | | |
| | | Bluetooth® 4.0 dongle to PC VMUX Lite (1channel); | x | | |
| PT02497 | 73447 | VMUX standard (8 channels) | | | x |
| PT60996 | 72945 | VMUX Standard Software (up to 32 tools) | | | x |
| PT99492 | 65650 | Two 3-Volt Batteries, CR2032 | | | |
| PT02498 | 73024 | Bluetooth® 4.0 Indicator for 0.080-0.75" gages | | | |
| PT02499 | 73025 | Bluetooth® 4.0 Indicator for 0.75-12" gages | | | |

Larger sizes available on special order.
Gages are also available with dial indicators on special order.



Extensions from 2-1/2 - 6" can be added to the 781XT, enabling internal measurements in deep hole bores

781BXTZ-500



S781BXTGZ



770BXTZ-250 Bore Gage with PT24272 Depth Stop Collar



ELECTRONIC BORE GAGES

770BXT ELECTRONIC BORE GAGES WITH IP67 PROTECTION (WITH OUTPUT)

.080-12"/2-300MM

770BXT Electronic Internal Micrometers provide IP67 level of protection against coolant, water, dirt and dust in hostile shop environments. In addition, they offer extended travel, reducing the need to exchange anvils.



770BXT-138

FEATURES

- Wide measurement range without changing anvils
- Resolution to .00005" (0.001mm)
- Large high-contrast LCD digital readout is easy to read and reduces error
- RS232, USB, wireless output
- Carbide measuring faces on sizes above 1/2" (12.5mm) diameter
- Extensions available for deep holes
- Includes instant inch/millimeter conversion and preset + and - functions
- Precision ratchet stop provides correct contact pressure for accurate readings
- Each micrometer bore gage with head comes with a wooden case, complete with setting ring, contacts, adjusting wrench, spare battery, and instructions



NEW!

BORE GAGES

780XT Electronic Internal Micrometers, 2-Point Contact (.080-.250" (2-6mm) Range)

| Cat. No. | EDP | Range | | Accuracy | | Approx. Meas. Depth | | Ring Diameter | |
|-------------|-------|-----------|-------|----------|------|---------------------|----|---------------|------|
| | | in | mm | in | mm | in | mm | in | mm |
| 770BXTZ-100 | 72539 | .080-.100 | 2-2.5 | .00015 | .004 | 3/8 | 9 | .100" | 2.54 |
| 770BXTZ-120 | 72540 | .100-.120 | 2.5-3 | | | | | | |
| 770BXTZ-160 | 72541 | .120-.160 | 3-4 | .00015 | .004 | 15/32 | 12 | .160" | 4.06 |
| 770BXTZ-200 | 72542 | .160-.200 | 4-5 | .00015 | .004 | 3/4 | 18 | .160" | 4.06 |
| 770BXTZ-250 | 72543 | .200-.250 | 5-6 | .00015 | .004 | 3/4 | 18 | .200" | 5.08 |

780XT Electronic Internal Micrometers, 3-Point Contact (1/4-12" (6-300mm) Range), Fixed Anvils

| Cat. No. | EDP | Range | | Accuracy | | Approx. Meas. Depth | | Ring Diameter | |
|-------------|-------|-------------|---------|----------|------|---------------------|-----|---------------|--------|
| | | in | mm | in | mm | in | mm | in | mm |
| 770BXTZ-312 | 72544 | 1/4 - 5/16 | 6-8 | .00015 | .004 | 2-1/4 | 58 | .3125 | 7.94 |
| 770BXTZ-375 | 72545 | 5/16 - 3/8 | 8-10 | | | | | | |
| 770BXTZ-500 | 72546 | 3/8 - 1/2 | 10-12.5 | .00015 | .004 | 2-1/4 | 58 | .500 | 12.7 |
| 770BXTZ-625 | 72547 | 1/2 - 5/8 | 12.5-16 | .00015 | .004 | 2-3/8 | 62 | .500 | 12.7 |
| 770BXTZ-750 | 72548 | 5/8 - 3/4 | 16-20 | .00015 | .004 | 2-5/8 | 66 | .750 | 19.05 |
| 770BXTZ-1 | 72549 | 3/4 - 1 | 20-25 | | | | | | |
| 770BXTZ-138 | 72562 | 1 - 1-3/8 | 25-35 | .00015 | .004 | 3-1/16 | 80 | 1.375 | 34.93 |
| 770BXTZ-2 | 72563 | 1-3/8 - 2 | 35-50 | | | | | | |
| 770BXTZ-258 | 72564 | 2 - 2-5/8 | 50-65 | .00020 | .005 | 3-1/16 | 80 | 2.625 | 65.68 |
| 770BXTZ-314 | 72566 | 2-5/8-3-1/4 | 65-80 | | | | | | |
| 770BXTZ-4 | 72567 | 3-1/4 - 4 | 80-100 | .00020 | .005 | 4 | 100 | 3.250 | 82.55 |
| 770BXTZ-5 | 72568 | 4 - 5 | 100-125 | .00025 | .006 | 4-1/2 | 115 | 5.0 | 127.00 |
| 770BXTZ-6 | 72569 | 5 - 6 | 125-150 | | | | | | |
| 770BXTZ-7 | 72570 | 6 - 7 | 150-175 | .00030 | .007 | 4-1/2 | 115 | 7.0 | 177.80 |
| 770BXTZ-8 | 72571 | 7 - 8 | 175-200 | | | | | | |
| 770BXTZ-9 | 72572 | 8 - 9 | 200-225 | .00030 | .007 | 4-5/8 | 118 | 9.0 | 228.60 |
| 770BXTZ-10 | 72573 | 9 - 10 | 225-250 | | | | | | |
| 770BXTZ-11 | 72574 | 10 - 11 | 250-275 | .00035 | .009 | 4-5/8 | 118 | 11.0 | 279.40 |
| 770BXTZ-12 | 72575 | 11 - 12 | 275-300 | | | | | | |

See next page for sets.

Accessories for 770BXT Electronic Internal Micrometers

| Part No. | EDP | Description | Required for Initial Bluetooth® Connection | |
|----------|-------|---|--|-------------|
| | | | 1 Device | > 1 Devices |
| PT61055 | 72941 | 770B Output Cable to USB | | |
| PT61057 | 72942 | 770B Output Cable to USB with Footswitch | | |
| | | Free VMUX Software - 1 channel; visit starrett.com | x | |
| PT02497 | 73447 | Bluetooth® 4.0 dongle to PC Vmux Lite (1 channel); VMUX standard (8 channels) | x | x |
| PT60996 | 72945 | VMUX Standard Software (up to 32 tools) | | x |
| PT99492 | 65650 | Two 3-Volt Batteries, CR2032 | | |

See next page for sets.

IP PROTECTION

An IP number is composed of two numbers, the first referring to protection against solid objects and the second against liquids.



First number 6: Totally protected against dust

Second number 7: Protection against submersion in water under standardized conditions of pressure for 30 minutes



ELECTRONIC BORE GAGES

770BXT ELECTRONIC BORE GAGES WITH IP67 PROTECTION (WITH OUTPUT)

See specifications on previous page



770BXT Electronic Internal Micrometer Sets, 2-Point Contact (.080-.250" [2-6mm] Range)

| Cat. No. | EDP | Range | | Number of Heads | Number of Rings |
|-----------|-------|-----------|-----|-----------------|-----------------|
| | | in | mm | | |
| S770BXTBZ | 72576 | .080-.250 | 2-6 | | |

770BXT Electronic Internal Micrometer Sets, 3-Point Contact (1/4-8" [6-200mm] Range), Fixed anvils

| Cat. No. | EDP | Range | | Number of Heads | Number of Rings |
|-----------|-------|---------|---------|-----------------|-----------------|
| | | in | mm | | |
| S770BXTCZ | 72577 | 1/4-3/8 | 6-10 | 2 | 1 |
| S770BXTDZ | 72578 | 3/8-3/4 | 10-20 | 3 | 2 |
| S770BXTFZ | 72579 | 3/4-2 | 20-50 | 3 | 2 |
| S770BXTGZ | 72582 | 4-8 | 100-200 | 4 | 2 |
| S770BXTLZ | 72583 | 6-8 | 150-200 | 2 | 1 |



S770BXTKZ



VERNIER BORE GAGES

78XT BORE GAGES

.080-12"/1-300MM

The 78XT Bore Gages feature extended travel, reducing the need to exchange anvils. The ground contact points seat the internal micrometer faster and more accurately than the spherical contacts found in other gages. These rugged and accurate internal micrometers are available individually or in economical sets from .080-12" (2-300mm).

| 78XT Bore Gages, 2-Point Contact (.080-.250" Range) | | | | | |
|---|-------|------------|---------------|----------------------------------|----------------------------|
| Cat. No. | EDP | Range (in) | Accuracy (in) | Approximate Measuring Depth (in) | Setting Ring Diameter (in) |
| 78XTZ-100 | 68124 | .080-.100 | 0.00015 | 3/8 | .100 |
| 78XTZ-120 | 68125 | .100-.120 | | | |
| 78XTZ-160 | 68126 | .120-.160 | 0.00015 | 15/32 | .160 |
| 78XTZ-200 | 68127 | .160-.200 | 0.00015 | 3/4 | .160 |
| 78XTZ-250 | 68128 | .200-.250 | | | .200 |

| 78XT Bore Gages, 3-Point Contact (1/4-12" Range) | | | | | |
|--|-------|-------------|---------------|----------------------------------|----------------------------|
| Cat. No. | EDP | Range (in) | Accuracy (in) | Approximate Measuring Depth (in) | Setting Ring Diameter (in) |
| 78XTZ-312 | 68129 | 1/4-5/16 | | | .3125 |
| 78XTZ-375 | 68130 | 5/16-3/8 | .00015 | 2-1/4 | .3125 |
| 78XTZ-500 | 68131 | 3/8-1/2 | | | .500 |
| 78XTZ-625 | 68132 | 1/2-5/8 | .00015 | 2-7/16 | .500 |
| 78XTZ-750 | 68133 | 5/8-3/4 | | | .750 |
| 78XTZ-1 | 68134 | 3/4-1 | .00015 | 2-5/8 | .750 |
| 78XTZ-138 | 67674 | 1-1-3/8 | | | 1.375 |
| 78XTZ-2 | 67675 | 1-3/8-2 | .00015 | 3-1/16 | 1.375 |
| 78XTZ-258 | 67676 | 2-2-5/8 | | | 2.625 |
| 78XTZ-314 | 67677 | 2-5/8-3-1/4 | .00020 | 3-1/16 | 2.625 |
| 78XTZ-4 | 67678 | 3-1/4-4 | .00020 | 4 | 3.250 |
| 78XTZ-5 | 67679 | 4-5 | .00025 | 4 | 5.0 |
| 78XTZ-6 | 67680 | 5-6 | .00025 | 4-1/2 | 5.0 |
| 78XTZ-7 | 67681 | 6-7 | | | 7.0 |
| 78XTZ-8 | 67682 | 7-8 | .00030 | 4-1/2 | 7.0 |
| 78XTZ-9 | 67857 | 8-9 | | | 9.0 |
| 78XTZ-10 | 67858 | 9-10 | .00030 | 4-5/8 | 9.0 |
| 78XTZ-11 | 67859 | 10-11 | | | |
| 78XTZ-12 | 67860 | 11-12 | .00035 | 4-5/8 | 11.0 |

| 78XT Sets, 2-Point Contact (.250" Range) | | | | |
|--|-------|------------|-----------------|-----------------|
| Cat. No. | EDP | Range (in) | Number of Heads | Number of Rings |
| S78XTBZ | 68152 | .120-.250 | 3 | 2 |

| 78XT Sets, 3-Point Contact (1/4-4" Range) | | | | |
|---|-------|------------|-----------------|-----------------|
| Cat. No. | EDP | Range (in) | Number of Heads | Number of Rings |
| S78XTCZ | 68153 | 1/4-3/8 | 2 | 1 |
| S78XTDZ | 68154 | 3/8-3/4 | 3 | 2 |
| S78XTEZ | 67683 | 3/4-2 | 3 | 2 |
| S78XTFZ | 67684 | 2-4 | 3 | 2 |



78XTZ-2

FEATURES

- Wide measurement range without changing anvils
- Resolution from .0001" (0.0025mm) on the 2-point contact tool up to 3/4" (20mm) and .00025" (0.005mm) on the 3-point contact tools ranging from 3/4"-12" (20mm - 300mm)
- Tungsten carbide measuring faces on all 3-point heads above 1/2" (12.5mm)
- Ratchet stop ensures consistent measurements
- Self-centering contacts for true readings
- Blind bore measuring capability above 1/2" (12.5mm) diameter
- Extensions available up to 6" (150mm) for deep hole measuring
- Setting rings included
- Depth stop/collar also available for .080"-.250" (1-6mm) range
- Each micrometer bore gage is furnished in a case, complete with setting ring, contacts, wrenches, and instructions



78XTZ-138 measuring a bore.



ELECTRONIC BORE GAGES

78MXT BORE GAGES

See specifications on previous page

78MXT Bore Gages, 2-Point Contact (1-6mm Range)

| Cat. No. | EDP | Range (mm) | Accuracy (mm) | Approximate Measuring Depth (mm) | Setting Ring Dia (mm) |
|-------------|-------|------------|---------------|----------------------------------|-----------------------|
| 78MXTZ-1.15 | 68135 | 1-1.15 | 0.003 | 6 | 1 |
| 78MXTZ-1.3 | 68136 | 1.15-1.3 | | | |
| 78MXTZ-1.5 | 68137 | 1.3-1.5 | 0.003 | 6 | 1.3 |
| 78MXTZ-1.75 | 68138 | 1.5-1.75 | | | |
| 78MXTZ-2 | 68139 | 1.75-2 | 0.003 | 8 | 1.75 |
| 78MXTZ-2.5 | 68140 | 2-2.5 | 0.004 | 9 | 2.5 |
| 78MXTZ-3 | 68141 | 2.5-3 | | | |
| 78MXTZ-4 | 68142 | 3-4 | 0.004 | 12 | 4 |
| 78MXTZ-5 | 68143 | 4-5 | 0.004 | 18 | 4 |
| 78MXTZ-6 | 68144 | 5-6 | 0.004 | 18 | 5 |

78MXT Bore Gages, 3-Point Contact (6-300mm Range)

| Cat. No. | EDP | Range (mm) | Accuracy (mm) | Approximate Measuring Depth (mm) | Setting Ring Dia (mm) |
|-------------|-------|------------|---------------|----------------------------------|-----------------------|
| 78MXTZ-8 | 68145 | 6-8mm | 0.004 | 58 | 8 |
| 78MXTZ-10 | 68146 | 8-10mm | | | |
| 78MXTZ-12.5 | 68147 | 10-12.5mm | 0.004 | 58 | 12.5 |
| 78MXTZ-16 | 68148 | 12.5-16mm | 0.004 | 62 | 12.5 |
| 78MXTZ-20 | 68149 | 16-20mm | 0.004 | 62 | 20 |
| 78MXTZ-25 | 68150 | 20-25mm | 0.004 | 66 | 20 |
| 78MXTZ-35 | 67861 | 25-35mm | 0.004 | 66 | 35 |
| 78MXTZ-50 | 67862 | 35-50mm | 0.004 | 80 | 35 |
| 78MXTZ-65 | 67863 | 50-65mm | | | |
| 78MXTZ-80 | 68650 | 65-80mm | 0.005 | 80 | 65 |
| 78MXTZ-100 | 67864 | 80-100mm | 0.005 | 100 | 80 |
| 78MXTZ-125 | 67865 | 100-125mm | 0.006 | 115 | 125 |
| 78MXTZ-150 | 67866 | 125-150mm | | | |
| 78MXTZ-175 | 67867 | 150-175mm | 0.007 | 115 | 175 |
| 78MXTZ-200 | 67868 | 175-200mm | | | |
| 78MXTZ-225 | 67869 | 200-225mm | 0.008 | 118 | 225 |
| 78MXTZ-250 | 67870 | 225-250mm | | | |
| 78MXTZ-275 | 67871 | 250-275mm | 0.009 | 118 | 275 |
| 78MXTZ-300 | 67872 | 275-300mm | | | |

78MXT Sets, 2-Point Contact (2-6mm Range)

| Cat. No. | EDP | Range (mm) | Number of Heads | Number of Rings |
|----------|-------|------------|-----------------|-----------------|
| S78MXTAZ | 68155 | 2-3 | 2 | 1 |
| S78MXTBZ | 68156 | 3-6 | 3 | 2 |

78XT Sets, 3-Point Contact (6-100mm Range)

| Cat. No. | EDP | Range (mm) | Number of Heads | Number of Rings |
|----------|-------|------------|-----------------|-----------------|
| S78MXTCZ | 68157 | 6-10 | 2 | 1 |
| S78MXTDZ | 68158 | 10-20 | 3 | 2 |
| S78MXTFZ | 67873 | 20-50 | 3 | 2 |
| S78MXTFZ | 67874 | 50-100 | 3 | 2 |



780MXTZ-150 in case



ADDITIONAL OPTIONS FOR 781B, 770B, 78 BORE GAGES

SPARE MEASURING HEADS

| Cat. No. | EDP | Range (in) |
|----------|-------|-------------|
| HEAD100 | 73075 | 0.080-0.100 |
| HEAD120 | 73078 | 0.100-0.120 |
| HEAD160 | 73080 | 0.120-0.160 |
| HEAD200 | 73082 | 0.160-0.200 |
| HEAD250 | 73083 | 0.200-0.250 |
| HEAD312 | 73085 | 1/4-5/16 |
| HEAD375 | 73087 | 5/16-3/8 |
| HEAD500 | 73090 | 3/8-1/2 |
| HEAD625 | 73092 | 1/2-5/8 |
| HEAD750 | 73094 | 5/8-3/4 |
| HEAD1 | 73073 | 3/4-1.0 |
| HEAD138 | 73079 | 1-1-3/8 |
| HEAD2 | 73081 | 1-3/8-2 |
| HEAD258 | 73084 | 2-2 5/8 |
| HEAD314 | 73086 | 2-5/8-3-1/4 |
| HEAD4 | 73088 | 3-1/4-4 |
| HEAD5 | 73089 | 4.0-5.0 |
| HEAD6 | 73091 | 5.0-6.0 |
| HEAD7 | 73093 | 6.0-7.0 |
| HEAD8 | 73095 | 7.0-8.0 |
| HEAD9 | 73096 | 8.0-9.0 |
| HEAD10 | 73074 | 9.0-10.0 |
| HEAD11 | 73076 | 10.0-11.0 |
| HEAD12 | 73077 | 11.0-12.0 |

SPARE SETTING RINGS

| Cat. No. | EDP | Range (in) |
|----------|-------|------------|
| RING100 | 73097 | 0.1000 |
| RING160 | 73100 | 0.1600 |
| RING200 | 73101 | 0.2000 |
| RING312 | 73103 | 5/16 |
| RING500 | 73106 | 1/2 |
| RING750 | 73108 | 3/4 |
| RING138 | 73099 | 1-3/8 |
| RING258 | 73102 | 2-5/8 |
| RING314 | 73104 | 3-1/4 |
| RING5 | 73105 | 5 |
| RING7 | 73107 | 7 |
| RING9 | 73109 | 9 |
| RING11 | 73098 | 11 |



INREACH EXTENSIONS FOR 770B, 781B, 781 BORE GAGES

Extensions from 2-1/2 - 6" can be added to both the 770BXT and 78XT, enabling internal measurements in deep hole bores (Multiple extensions can also be used).

| Internal Extensions | | | | | | |
|---------------------|-------|-----------|-----|------------------------------|------------|---------|
| Cat. No. | EDP | Ext. Size | | Fits Models | Model Size | |
| | | in | mm | | in | mm |
| 78/782F | 65484 | 2.5 | 63 | 78XT/770BXT/781BXT-312-375 | 1/4-3/8 | 6-10 |
| 78/782G | 65485 | 3 | 75 | 78XT/770BXT/781BXT-375-500 | 3/8-1/2 | 10-12.5 |
| 78/782H | 65486 | 4 | 100 | 78XT/770BXT/781BXT-625-750 | 1/2-3/4 | 12.5-20 |
| 78/782J | 65487 | 6 | 150 | 78XT/770BXT/781BXT-1 thru 2 | 3/4-2 | 20-50 |
| 78/782K | 65488 | 6 | 150 | 78XT/770BXT/781BXT-2 thru 12 | 2-12 | 50-300 |



78-782J with 770BZ-2



SPECIAL BORE GAGE MEASURING HEADS

We offer several configurations of special purpose measuring heads for 780, and 781 Bore Gages, available by special order. Some, but not all, of these will also work with the 78 Bore Gages.

GROOVE MEASURING HEADS

- **Groove.** Available as a 2-point system for ovality measurement.
- Various 2-point anvil forms available with diameters from .080-12" (2-300mm).
- **Grooves.** Available as a 3-point system
- Various 3-point anvil forms available for diameters from .250-12" (6-300mm).

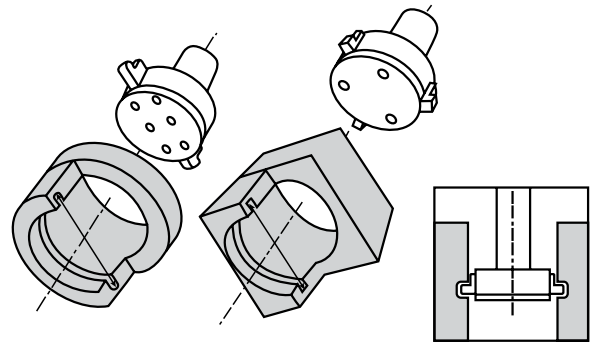

THREAD MEASURING HEADS

Thread Measuring Heads are available as two point system from 8 to 5/16" (M4-8mm) and three point system from 3/8"-12" (9.5-300mm). Most forms available including UNC, UNF, UNJ, UNS, Buttress, Acme, Multi-start, LH and RH.

- **Thread.** Thread forms available as a 3-point system.
- **Internal.** To measure effective (functional) diameter, pitch diameter.
- Available as two point system from 8 to 5/16" (M4-8mm) Available as three point system from 3/8"-12" (9.5-300mm).
- Most forms available including UNC, UNF, UNJ, UNS, Buttress, Acme, Multi-start, LH and RH.

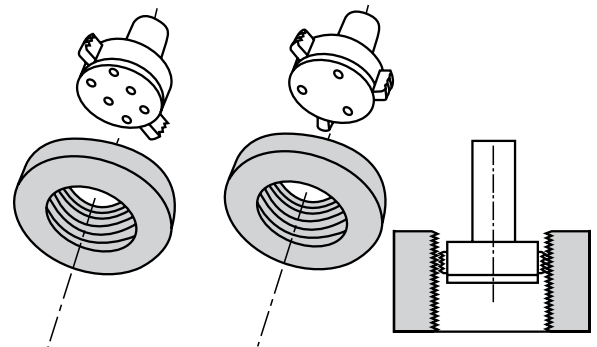

SPHERICAL RADIUS MEASURING HEADS

- **Spherical Radius.** Available as 2-point to measure ovality or with 3-point contact.
- Available with diameters from .236-3.93" (6-100mm).
- **3-Point Spherical.** Available in .118-12" (3-300mm) range.
- Gives good repeatability even when somewhat out of line with bore center.

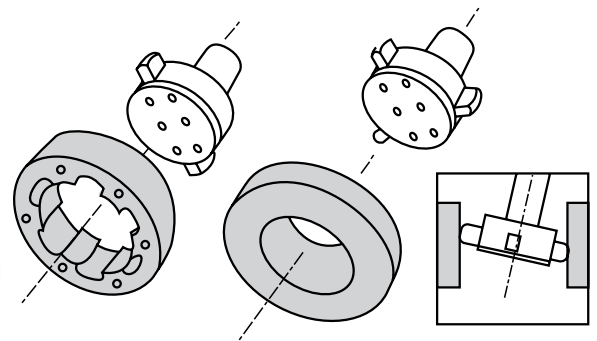

DIAL BORE GAGES

NEW!

3089 DIAL BORE GAGES

The 3089 Dial Bore Gages offer precision, a full compliment of features and excellent value.

| 3089 Dial Bore Gages | | | |
|---------------------------------|-------|--|--|
| Cat. No. | EDP | Measuring Range | Probe Depth |
| 3089Z-131-715J | 12456 | 0.7-1.5" | 6" |
| 3089Z-131-1424J | 12457 | 1.4-2.4" | 6" |
| 3089Z-131-26J | 12458 | 2-6" | 6" |
| 3089M-181-35J | 72948 | 18-35mm | 300mm |
| 3089M-181-50J | 72949 | 35-50mm | 300mm |
| 3089M-181-160J | 72950 | 50-160mm | 300mm |
| 3089 Dial Bore Gage Sets | | | |
| Cat. No. | EDP | Measuring Range | Set Includes |
| 3089Z-131-26J | 13016 | 0.7-6" | 3089Z-131-715J, 3089Z-131-1424J, 3089Z-131-26J |
| S3089MZ-181-160J | 13015 | 50-160mm | 3089M-181-35J, 3089M-181-50J, 3089M-181-160J |
| 3089 Dial Bore Gage Accessories | | | |
| Cat. No. | EDP | Description | |
| 3089-RS36B | 72969 | Bore gage setter with 36 Grade B gage blocks | |

FEATURES

- Ergonomic design with non-slip insulating grip
- Carbide contacts for extended wear
- 2-point contact
- All anvils laser marked for easy selection
- Gage chart for quick and easy anvil selection
- Includes sturdy aluminum case with cutouts for gage and all accessories
- Resolution: .0005"

BORE GAGES



3089Z-131-26J



3089-RS36B



3089Z-131-26J

Probes



DIAL BORE GAGES

82, 82M DIAL BORE GAGES

.107-1.565"/2.7-39.75MM

Dial bore gages are available in convenient sets or with individual probes and dial indicators. Each set consists of a dial indicator, a body and actuating rod, two adjusting wrenches and the probes as specified below.

The head may be ordered separately (includes dial indicator, body, and two adjusting wrenches). Individual probes can also be ordered as listed. All probes are furnished with an actuating rod. These gages are also available with electronic indicators by special order.

Measurements are taken by comparison so some type of set master should be used as a reference standard. We recommend setting as close to the hole being measured as possible, and this can be easily done with gage blocks or with a micrometer. We can also furnish master setting rings by request.

- The split-ball contact is self-centering and the two-point contact makes the gage useful for detecting hole geometry problems like taper, bell-mouth and out-of-roundness
- Reads to .0001" and 0.002mm
- Useful for controlling approach to tolerance without removing the workpiece from a machine
- Interchangeable probes are hard chrome plated and polished
- Sets furnished in attractive, protective case.

A Sets Individual Probes Only for 82 and 82M Bore Gages

| Cat. No. | EDP | Range in | mm |
|----------|-------|-------------|-----------|
| 82A2 | 66015 | .107-.140 | 2.7-3.55 |
| 82A3 | 66016 | .139-.172 | 3.55-4.35 |
| 82A4 | 66017 | .171-.203 | 4.35-5.15 |
| 82A5 | 66018 | .202-.234 | 5.15-5.95 |
| 82A6 | 66019 | .233-.266 | 5.9-6.76 |

B Sets Individual Probes Only for 82 and 82M Bore Gages

| Cat. No. | EDP | Range in | mm |
|----------|-------|-------------|------------|
| 82B2 | 66020 | .217-.281 | 5.5-7.15 |
| 82B3 | 66021 | .279-.344 | 7.1-8.75 |
| 82B4 | 66022 | .342-.405 | 8.7-10.3 |
| 82B5 | 66023 | .403-.469 | 10.25-11.9 |
| 82B6 | 66024 | .467-.532 | 11.9-13.5 |
| 82B7 | 66025 | .530-.594 | 13.5-15.1 |

C Sets Individual Probes Only for 82 and 82M Bore Gages

| Cat. No. | EDP | Range in | mm |
|----------|-------|-------------|-------------|
| 82C2 | 66028 | .560-.690 | 14.2-17.5 |
| 82C3 | 66029 | .685-.815 | 17.4-20.7 |
| 82C4 | 66030 | .810-.940 | 20.6-23.9 |
| 82C5 | 66031 | .935-1.065 | 23.75-27.05 |
| 82C6 | 66032 | 1.060-1.190 | 26.9-30.2 |
| 82C7 | 66033 | 1.185-1.315 | 30.1-33.4 |
| 82C8 | 66034 | 1.310-1.440 | 33.3-36.6 |
| 82C9 | 66035 | 1.435-1.565 | 36.5-39.75 |

All probes come complete with actuating rod.



82 Dial Bore Gages

| Complete Sets Cat. No. | EDP | Heads Cat. No. | EDP | Total Range | Number of Probes | Range Each Probe | Max. Bore Depth | Graduation |
|---------------------------|-------|-------------------|-------|-------------|---------------------|---|--------------------|------------|
| 82AZ | 55791 | 82AB1 | 66013 | .107-.266" | 5 | .107-.140"; .139-.172"; .171-.203"; .202-.234"; .233-.266" | 13/16" | .0001" |
| 82BZ | 55792 | 82AB1 | 66013 | .217-.594" | 6 | .217-.281"; .279-.344"; .342-.405"; .403-.469"; .467-.532"; .530-.594" | 1-1/2" 1-3/4" | .0001" |
| 82CZ | 55793 | 82C1 | 66026 | .560-1.565" | 8 | .560-.690"; .685-.815"; .810-.940"; .935-1.065"; 1.060-1.190"; 1.185-1.315"; 1.310-1.440"; 1.435-1.565" | 2-1/2" 5" | .0001" |

82M Dial Bore Gages

| Complete Sets Cat. No. | EDP | Heads Cat. No. | EDP | Total Range | Number of Probes | Range Each Probe | Max. Bore Depth | Graduation |
|---------------------------|-------|-------------------|-------|--------------|---------------------|---|--------------------|------------|
| 82MAZ | 66010 | 82MAB1 | 66014 | 2.7-6.76mm | 5 | 2.7-3.55mm; 3.55-4.35mm; 4.35-5.15mm; 5.15-5.95mm; 5.95-6.76mm | 20.6mm | 0.002 mm |
| 82MBZ | 66011 | 82MAB1 | 66014 | 5.5-15.1mm | 6 | 5.5-7.15mm; 7.1-8.75mm; 8.7-10.3mm 10.25-11.9mm; 11.9-13.5mm; 13.5-15.1mm | 38mm 44mm | 0.002 mm |
| 82MCZ | 66012 | 82MC1 | 66027 | 14.2-39.75mm | 8 | 14.2-17.5mm; 17.4-20.7mm; 20.6-23.9mm 23.75-27.05mm; 26.9-30.2mm; 30.1-33.4mm; 33.3-36.6mm; 36.5-39.75mm | 63mm 125mm* | 0.002 mm |

* Includes insertion of gage body into bore.



DIAL BORE GAGES

84A, 84MA DIAL BORE GAGES

1-1/2 – 12-1/8"/38-317.5MM

These fractional bore gages allow for bore measurements beyond the size range of our 82 Bore Gage.

They are comparison gages and should be set with a master ring gage, gage blocks with parallel jaws, outside micrometers or vernier calipers. Ring gages are available by request, quoted by application. Good practice is to set the gage to zero, as near to the desired dimension as possible.

Gages are well balanced, easy to use and have the following features:

- Can be easily held to inspect bores and hole sizes without removing the workpiece
- An adjustable range screw and two centralizing plungers provide accurate, three-point contact for tool alignment in larger bores
- All contacts and centralized plungers are hardened tool steel for wear and spring-loaded for sensitivity
- The housing and knurled handle are aluminum for light weight and good balance
- Dial indicators have jewel bearings for sensitivity
- Bore depths are also available up to 12" (300mm) in 1" (25mm) increments on special order
- Furnished in finished wood case
- Available with longer reach lengths, carbide contacts or electronic indicators with output capability from our special order division



84MAZ-161-6

84AZ-111-5

| 84A Dial Bore Gages (1-1/2 - 12-1/2" Range) | | | | | | | |
|---|-------|----------------------------|------|---|-----------------|----------------|-----------------|
| Cat. No. | EDP | Total Range with Extension | Ext. | Range Each Extension (inches) | Max. Bore Depth | Plunger Travel | Indicator Grad. |
| 84AZ-111-4J | 00026 | 1-1/2-3" | 12 | 1.500-1.625", 1.625-1.750", 1.750-1.875", 1.875-2.000", 2.000-2.125", 2.125-2.250", | 3" | .020" | .0001" |
| 84AZ-134-4J | 00030 | | | 2.250-2.375", 2.375-2.500", 2.500-2.625", 2.625-2.750", 2.750-2.875", 2.875-3.000" | | | |
| 84AZ-111-5J | 00027 | 3-5-1/16" | 11 | 3.000-3.187", 3.187-3.375", 3.375-3.562", 3.562-3.750", 3.750-3.937", 3.937- | 6" | .030" | .0001" |
| 84AZ-134-5J | 00031 | | | 4.125", 4.150-4.312", 4.312-4.500", 4.500-4.687", 4.687-4.875", 4.875-5.062" | | | |
| 84AZ-111-6J | 00028 | 5-8" | 4 | 5.000-5.750", 5.750-6.500", 6.500-7.250", 7.250-8.000" | 6" | .030" | .0001" |
| 84AZ-134-6J | 00032 | | | | | | |
| 84AZ-111-7J | 00029 | 8-12-1/2" | 3 | 8.000-9.500", 9.500-11.000", 11.000-12.500" | 7" | .030" | .0001" |
| 84AZ-134-7J | 00033 | | | | | | |

| 84MA Dial Bore Gages (38.1 - 317.5mm Range) | | | | | | | |
|---|-------|----------------------------|------|--|-----------------|----------------|-----------------|
| Catalog No. | EDP | Total Range with Extension | Ext. | Range Each Extension (mm) | Max. Bore Depth | Plunger Travel | Indicator Grad. |
| 84MAZ-161-4J | 00034 | 3.175-76.2mm | 12 | 38.1-41.28mm, 41.28-44.45mm, 44.45-47.62mm, 47.62-50.8mm, 50.8 -53.98mm, | 75mm | 0.51mm | 0.002 mm |
| 84MAZ-181-4J | 00038 | | | 53.98-57.15mm, 57.15-60.32mm, 60.32-63.5mm, 63.5-66.68mm, 66.68-69.85mm, 69.85-73.02mm, 73.02-76.2mm | | | |
| 84MAZ-161-5J | 00035 | 76.2-128.58mm | 11 | 76.2-80.96mm, 80.96-85.72mm, 85.72-90.49mm, 90.49-95.25mm, 95.25-100.01mm, | 150mm | 0.76mm | 0.002 mm |
| 84MAZ-181-5J | 00039 | | | 100.01-104.78mm, 104.78-109.54mm, 109.54- 114.3mm, 114.3-119.06mm, 119.06-123.82mm, 123.82-128.58mm | | | |
| 84MAZ-161-6J | 00036 | 127-203.2mm | 4 | 127-146.05mm, 146.05-165.1mm, 165.1-184.15mm, 184.15-203.2mm | 150mm | 0.76mm | 0.002 mm |
| 84MAZ-181-6J | 00040 | | | | | | |
| 84MAZ-161-7J | 00037 | 203.2-317.5mm | 3 | 203.2 - 241.3mm, 241.3 - 279.4mm, 279.4 - 317.5mm | 175mm | 0.76mm | 0.002 mm |
| 84MAZ-181-7J | 00041 | | | | | | |



BORE GAGE SYSTEMS

AccuPlug™ BORE GAGES

The AccuPlug consists of interchangeable indicators, handles, plugs, extensions and depth stops for a custom bore gage built specifically for your application needs.

The robust, easy to use AccuPlug range is designed to give the operator greater speed of use, unmatched measuring accuracy and superb repeatability, especially in harsh shop-floor environments. Advanced hand held ergonomics allied to an ingenious mechanical/electronic system render AccuPlug the easiest to operate Starrett bore gaging system to date. The flexible nature of the AccuPlug™ range means that they can be supplied fitted with easy to read electronic indicators (ideal for automatic data collection) or conventional analogue indicators.



FEATURES

- Ranges from 0.2362 - 11.0236" (6 - 280mm)
- Tough, robust construction
- Easy-to-use
- High accuracy dedicated plug-gages
- Flexible, modular
- Hand-held measurement
- Cost-effective
- High visibility display
- Protective indicator shroud (with some indicators)
- All setting rings supplied as standard with UKAS calibration certificates
- Repeatability: $\leq 1\mu\text{m}$
- Setting by means of a setting ring
- Quick and reliable measurement
- 2 - point measurement as standard
- Blind bore available
- Depth-stops available
- Extensions available for deeper bores
- Guide chamfer for easy entry into bore
- High durability, long-life plugs and contacts
- Easy to clean
- Plug body coatings: Hard-chrome (standard), T.i.N, Plain steel
- Measuring contacts: Tungsten carbide (standard), hard-chrome, ruby, ceramic



BORE GAGE SYSTEMS

AccuPlug™ BORE GAGES



802P-004

802P-002

802P-001

| AccuPlug™ | | | |
|---------------|----------------|---------|-----------|
| Regular Bore* | | | |
| Cat. No. | in | mm | Thread |
| 802P-001 | 0.2362-0.7874 | 6-20 | M6 x 0.75 |
| 802P-002 | 0.5906-0.9843 | 15-25 | M10 x 1 |
| 802P-003 | 0.9843-1.3780 | 25-35 | M10 x 1 |
| 802P-004 | 1.3780-1.7717 | 35-45 | M10 x 1 |
| 802P-005 | 1.7717-2.3622 | 45-60 | M10 x 1 |
| 802P-006 | 2.3622-3.1496 | 60-80 | M10 x 1 |
| 802P-007 | 3.1496-3.9370 | 80-100 | M10 x 1 |
| 802P-008 | 3.9370-4.9213 | 100-125 | M10 x 1 |
| 802P-009 | 4.9213-5.9055 | 125-150 | M10 x 1 |
| 802P-010 | 5.9055-6.8898 | 150-175 | M10 x 1 |
| 802P-011 | 6.8898-7.8740 | 175-200 | M10 x 1 |
| 802P-012 | 7.8740-8.8583 | 200-225 | M10 x 1 |
| 802P-013 | 8.8583-9.8425 | 225-250 | M10 x 1 |
| 802P-014 | 9.8425-11.0236 | 250-280 | M10 x 1 |
| Blind Bore* | | | |
| Cat. No. | in | mm | Thread |
| 802BB-001 | 0.2362-0.7874 | 6-20 | M6 x 0.75 |
| 802BB-002 | 0.5906-0.9843 | 15-25 | M10 x 1 |
| 802BB-003 | 0.9843-1.3780 | 25-35 | M10 x 1 |
| 802BB-004 | 1.3780-1.7717 | 35-45 | M10 x 1 |
| 802BB-005 | 1.7717-2.3622 | 45-60 | M10 x 1 |
| 802BB-006 | 2.3622-3.1496 | 60-80 | M10 x 1 |
| 802BB-007 | 3.1496-3.9370 | 80-100 | M10 x 1 |
| 802BB-008 | 3.9370-4.9213 | 100-125 | M10 x 1 |
| 802BB-009 | 4.9213-5.9055 | 125-150 | M10 x 1 |

*See Technical Specifications for plug ranges.

| Indicators | | |
|--------------|-------------|---|
| Cat No. | EDP | Description |
| 2900-4 | 09983 | 0.0005"/.001mm Electronic Indicator, Full Function, 3/8" Stem |
| 2900-4M | 09988 | 0.001mm Electronic Indicator, Full Functions, 8mm Stem |
| F2720AD | 49500 | 0.0005"/.001mm Electronic Indicator, Full Function with TIR Runout and Hold Function, 3/8" Stem, Analog Digital Display |
| F2720ADM | 49504 | 0.0005"/.001mm Electronic Indicator, Full Function with TIR Runout and Hold Function, 8mm Stem, Analog Digital Display |
| 647 | 00001 | 0.0005" Mechanical Indicator with 3/8" Stem |
| 647M | 00002 | 0.001mm Mechanical Indicator with 8mm Stem |
| M 10 Thread | M 6 Thread | Mini Electronic Indicator |
| 802H10MI-001 | 802H6MI-001 | With Shroud and M10 Holder Short 8mm Stem |
| 802H10MI-002 | 802H6MI-002 | With Shroud and M10 Holder Long 8mm Stem |





Setting Rings

| Cat. No. | Diameter Range | |
|-----------|-----------------|---------|
| | in | mm |
| 802RX-001 | 0.2362-0.3937 | 6-10 |
| 802RX-002 | 0.3937-0.7874 | 10-20 |
| 802RX-003 | 0.7874-0.9843 | 20-25 |
| 802RX-004 | 0.9843-1.1811 | 25-30 |
| 802RX-005 | 1.1811-1.5748 | 30-40 |
| 802RX-006 | 1.5748-1.9685 | 40-50 |
| 802RX-007 | 1.9685-2.3622 | 50-60 |
| 802RX-008 | 2.3622-2.7559 | 60-70 |
| 802RX-009 | 2.7559-3.1496 | 70-80 |
| 802RX-010 | 3.1496-3.5433 | 80-90 |
| 802RX-011 | 3.5433-3.9370 | 90-100 |
| 802RX-012 | 3.9370-4.5276 | 100-115 |
| 802RX-013 | 4.5276-5.1181 | 115-130 |
| 802RX-014 | 5.1181-5.7087 | 130-145 |
| 802RX-015 | 5.7087-6.2992 | 145-160 |
| 802RX-016 | 6.2992-6.6929 | 160-170 |
| 802RX-017 | 6.6929-7.0866 | 170-180 |
| 802RX-018 | 7.0866-7.4803 | 180-190 |
| 802RX-019 | 7.4803-7.8740 | 190-200 |
| 802RX-020 | 7.8740-8.2677 | 200-210 |
| 802RX-021 | 8.2677-8.6614 | 210-220 |
| 802RX-022 | 8.6614-9.0551 | 220-230 |
| 802RX-023 | 9.0551-9.4488 | 230-240 |
| 802RX-024 | 9.4488-9.8425 | 240-250 |
| 802RX-025 | 9.8425-10.2362 | 250-260 |
| 802RX-026 | 10.2362-10.6299 | 260-270 |
| 802RX-027 | 10.6299-11.0236 | 270-280 |

*Available with purchase of AccuPlug™



Depth Stop

| Cat. No. | Diameter Range | |
|-----------|----------------|----------|
| | in | mm |
| 802DS-001 | 2.3622-0.3347 | 6-8.5 |
| 802DS-002 | 0.3347-0.5118 | 8.5-13 |
| 802DS-003 | 0.5118-0.6890 | 13-17.5 |
| 802DS-004 | 0.6890-0.9843 | 17.5-25 |
| 802DS-005 | 0.9843-1.2795 | 25-32.5 |
| 802DS-006 | 1.2795-1.5748 | 32.5-40 |
| 802DS-007 | 1.5748-1.8701 | 40-47.5 |
| 802DS-008 | 1.8701-2.1654 | 47.5-55 |
| 802DS-009 | 2.1654-2.4606 | 55-62.5 |
| 802DS-010 | 2.4606-2.7559 | 62.5-70 |
| 802DS-011 | 2.7559-3.0512 | 70-77.5 |
| 802DS-012 | 3.0512-3.3465 | 77.5-85 |
| 802DS-013 | 3.3465-3.6417 | 85-92.5 |
| 802DS-014 | 3.6417-3.9370 | 92.5-100 |



Accessories

| M 6 Thread | | M 10 Thread | |
|------------|---------------------------|-------------|----------------------------|
| Cat No. | Description | Cat No. | Description |
| 802H6-001 | M6 Holder Short 3/8" Stem | 802H10-001 | M10 Holder Short 3/8" Stem |
| 802H6-002 | M6 Holder Long 3/8" Stem | 802H10-002 | M10 Holder Long 3/8" Stem |
| 802H6-003 | M6 Holder Short 8mm Stem | 802H10-003 | M10 Holder Short 8mm Stem |
| 802H6-004 | M6 Holder Long 8mm Stem | 802H10-004 | M10 Holder Long 8mm Stem |
| 802E6-001 | M6 100mm Extension | 802E10-001 | M10 100mm Extension |



BORE GAGE SYSTEMS

AccuPLUG™ BORE GAGING TECHNICAL SPECIFICATIONS

INDICATOR UNITS 8MM AND 3/8"

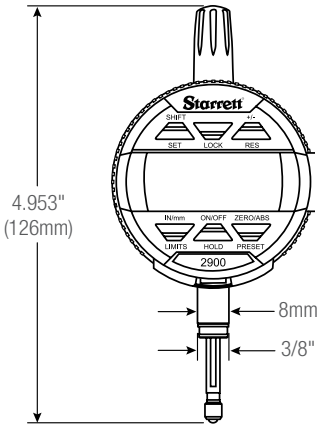

2900-4 and 2900-4M

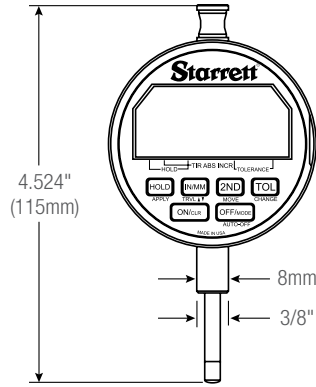

F2720AD and F2720ADM

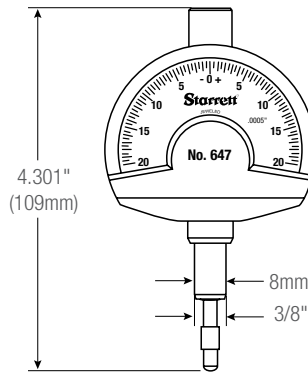

647 and 647M

MINI INDICATOR UNITS

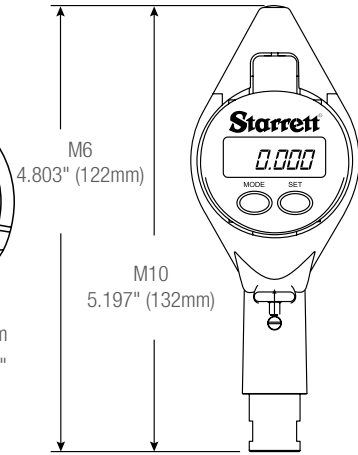

Mini indicator with shroud, short handle - M6 and M10

AccuPLUGS

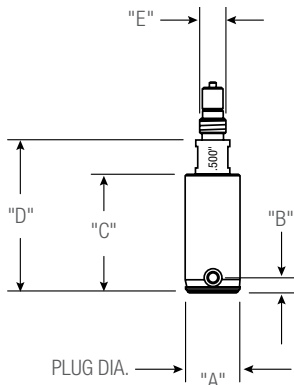

M6 AccuPlug

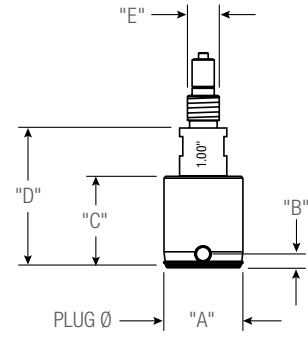

M10 AccuPlug

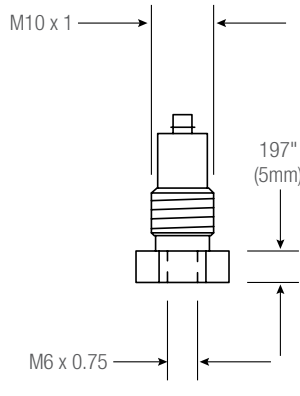

M6 to M10 Adapter

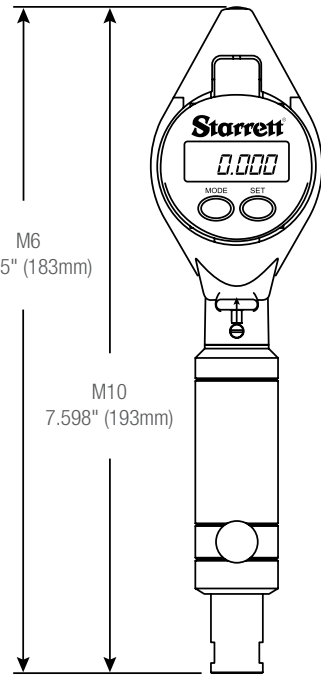

Mini indicator with shroud, long handle - M6 and M10

ACCESSORIES

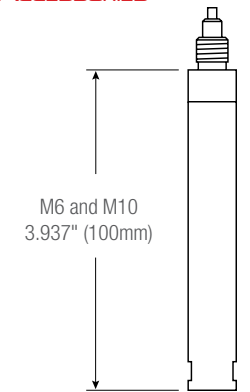

100mm Extension - M6 and M10

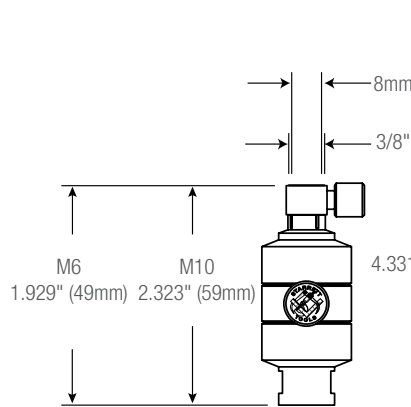

Short holder M6 and M10 with 3/8" or 8mm stem

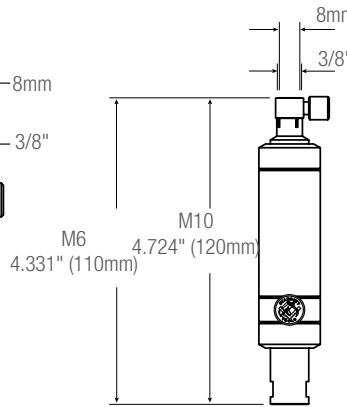

Long holder M6 and M10 with 3/8" or 8mm stem

AccuPlug Dimension Specifications

| Plug Diameter "A" | | Range | | B | | C | | D | | E |
|-------------------|--------|-------|------|-------|-----|-------|----|-------|------|-----------|
| in | mm | in | mm | in | mm | in | mm | in | mm | |
| 0.2362-0.7874 | 6-20 | .006 | 0.15 | .138 | 3.5 | 1.063 | 27 | 1.378 | 35 | M6 x 0.75 |
| 0.5906-1.7717 | 15-45 | .008 | 0.20 | .177 | 4.5 | 1.102 | 28 | 1.713 | 43.5 | M10 x 1 |
| 1.7717-2.756 | 45-70 | .008 | 0.20 | .217 | 5.5 | 1.102 | 28 | 1.732 | 44 | M10 x 1 |
| 2.756-11.0236 | 70-280 | .008 | 0.20 | .217" | 5.5 | 1.378 | 35 | 1.732 | 44 | M10 x 1 |





PRECISION MAKES THE DIFFERENCE

**YOU'VE HEARD OF THE
MOTHER OF INVENTION**

**NOW MEET THE FATHER
OF INNOVATION**

The L.S. Starrett Company was founded by Laroy Sunderland Starrett in 1880 who had patented the first combination square in 1878. Since then, we've been following in his footsteps, creating the kind of precision tools, gages and instruments that have made the name "Starrett" synonymous with "innovation." Laroy Starrett set very high standards and we steadfastly maintain them today.

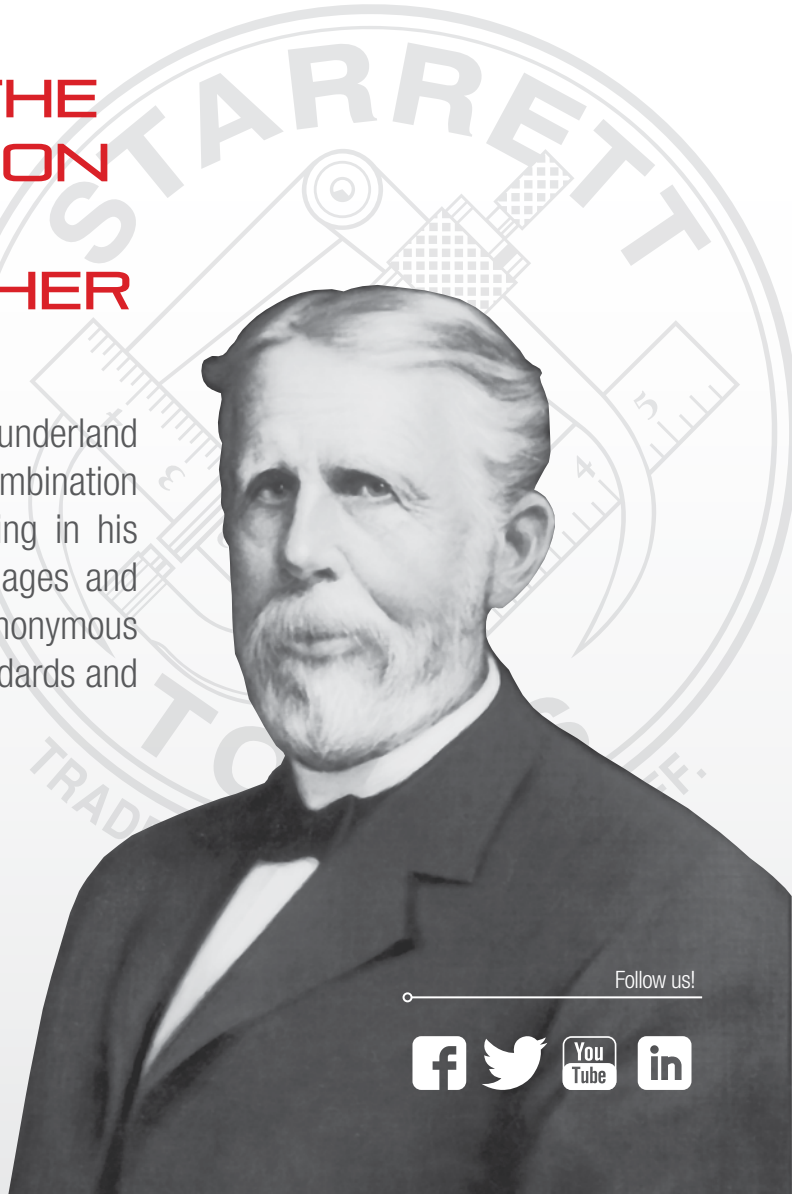

Starrett®

(978) 249-3551 • starrett.com

Follow us!





TOOL SETS

BASIC ELECTRONIC TOOL SETS

S766A

WITHOUT OUTPUT

Basic starter sets for electronic measuring include slide calipers and 1"/25mm micrometers. Two sets without output are offered: S766AZ for English units and S766MAZ for metric. Both sets include an attractive, protective case.



S766AZ

| S766AZ/EDP 12206 - Inch Set (without output) | |
|---|---|
| Cat. No. | Description |
| EC799A-6/150 | 0-6" (0-150mm) electronic slide caliper |
| 3732XFL-1 | 0-1" (0-25mm) electronic outside micrometer |
| S766MAZ/EDP 12207 - Millimeter Set (without output) | |
| Cat. No. | Description |
| EC799A-6/150 | 0-6" (0-150mm) Electronic Slide Caliper |
| 3732MEXFL-25 | 0-1" (0-25mm) Electronic Outside Micrometer |



S909Z

S909, S909M BASIC PRECISION MEASURING TOOL SETS

Sets contain three of the most commonly used precision tools. Furnished in attractive, protective cases.

| S909Z/EDP 65122 - Inch Set | |
|-----------------------------------|---|
| Cat. No. | Description |
| T436.1XRL-1 | 1" (25mm) Outside Micrometer with Carbide Faces |
| 120A-6 | 6" (150mm) Dial Caliper |
| C604R-6 | 6" Spring Tempered Precision Rule |
| S909MZ/EDP 65668 - Millimeter Set | |
| Cat. No. | Description |
| V436.1MXRL-25 | 1" (25mm) Outside Micrometer with Carbide Faces |
| 120M-150 | 6" (150mm) Dial Caliper |
| C635E-150 | 6" Spring Tempered Precision Rule |

S898Z AUTOMOTIVE INSPECTION SETS

Starrett has developed two kits that combine highly flexible configuration with several options to secure a measuring fixture to whatever surface is available to do the job. These kits will prove themselves to be invaluable to auto mechanics, providing an answer to the question: "How am I going to do that?".

FEATURES

- Allows very precise measurement for automotive repair
- Used to set proper distance or alignment
- Enables measuring fixture to be secured to any available surface
- Highly flexible configuration

| S898Z Inspection Kits | | |
|-----------------------|-------|---|
| Cat. No. | EDP | Description |
| S898Z-1 | 12438 | Inspection kit with indicator, pliers, Flex-O-Post and form-fit plastic case |
| S898Z-2 | 12437 | Inspection kit with indicator, pliers, Flex-O-Post, magnetic base and form-fit plastic case |



S898Z-1





DATA COLLECTION SYSTEMS

DataSure®

WIRELESS DATA COLLECTION

100% DATA COLLECTION: ERROR-FREE AND FAST

The DataSure Wireless Data Collection System allows real-time, 100% error-free data collection. From simple installations to systems covering thousands of square feet, data can be collected and analyzed much faster than with manual inspection and data entry.

With manual inspection data collection, the repetitive hand movements required to pick up tools, measure parts, put tools down, and then record results is time consuming. Furthermore, hand writing or keying in data leads to mistakes that result in scrap, excess inventory, and even rejected parts.

With DataSure, just measure and send for fast and error-free data.

DataSure also eliminates problems associated with data cables including placement, installation, safety and high cost. DataSure makes it easy to bring a precision measuring tool to the work, rather bringing the work to the tool.

DataSure is a full shop wireless solution. It works not only with Starrett tools, but also Mitutoyo, Sylvac, CDI Tools, Mahr, Tesa and other brands.



DATA SURE® TECHNICAL OVERVIEW

- Transmission users receive confirmation at the tool
- End Node radios store up to 10 readings in the event that the main system is down or busy
- Base system handles up to 100 tools, with 25 to 40 tools in a typical installation
- Each radio's range is approximately 65 feet (20 meters). Adding Routers can increase range in 100 foot increments.
- The DataSure system features a license-free 916MHz ISM band radio and a self-configuring and self-healing network
- Data acquisition from tools can be initiated by operator or host control
- Network, tool and end node battery status are all automatically monitored and recorded on screen and stored in the system's database
- The multi-mode software feature allows one tool to be connected to a Gateway for simple installations, or up to 20 multiplexers and 100 tools for complex shop environments
- Rechargeable routers are ideal for mobile applications and large-component data collection environments such as aircraft assembly hangars, large casting foundries, and auto body stamping facilities
- Easy-to-use included software offers user configurable names for tools and groups
- DataSure's flexibility means it can output data directly to the main application screen, your SPC software, a local or networked database, and CSV file format
- IP67 rating on end nodes
- Remote client access from another PC on your LAN

Contact Starrett for the DataSure Cost Calculator, application profiles, white papers, FAQ's and more at +1 (978) 249-3551.

DATA SURE HARDWARE

DataSure starts with superior engineering, state-of-the-art technology and rugged durability. End Nodes, Routers and Gateways are built to perform reliably in almost any environment. Sturdy construction and heavy duty materials help them withstand the rigors of everyday use under demanding conditions.



DataSure® WIRELESS DATA COLLECTION

DATA SURE® SHOP-FLOOR

The illustration (below) demonstrates how a large, multi-workstation shop might be networked with DataSure.

Tools at various locations collect data. The End Nodes send data to the nearest Router, and then to the Gateway, or directly to the Gateway if that is the best path. The Gateway sends a signal back through the same path to the End Node to confirm receipt of the data.

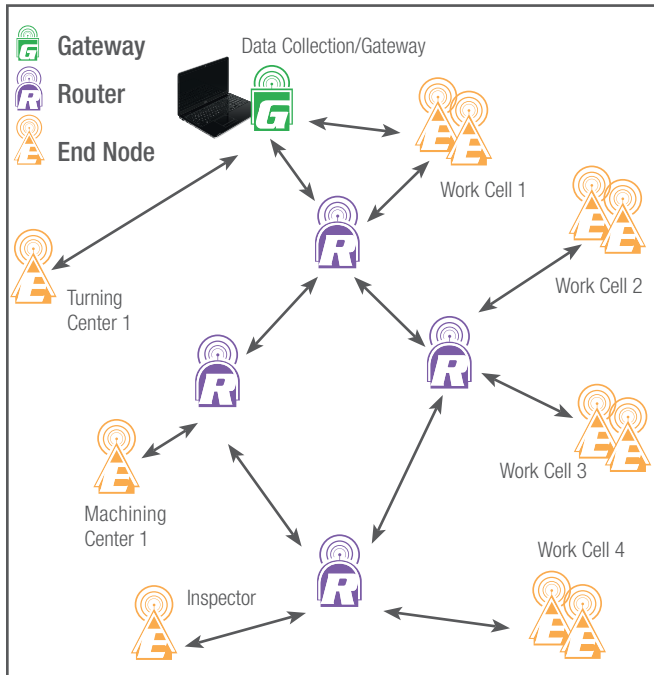

END NODE

The DataSure End Node plugs directly into digital tools. It sends measurement data and verifies receipt at the Gateway with a green light. The smaller 2nd Generation End Node has IP67 dust and water protection.



END NODE FEATURES

- User feedback LEDs
- On-tool data storage
- Adapts to most tools



1500-3A-1N

| Power | Range ft. | m | Size in | mm |
|----------------|-----------|----|------------------|--------------------|
| CR2450 lithium | 65 | 20 | 2.2 x 2.0 x 0.49 | 55.3 x 43.2 x 17.8 |

SOFTWARE

DataSure Advanced Wireless Data Collection Software connects and manages your tools, network, data and third party SPC applications.

GATEWAY

The DataSure Gateway is the central point for data collection and tool management and plugs directly into a PC through a USB port.

GATEWAY FEATURES

- USB
- Sends data to application or database
- Multi-file export features
- Unique system ID



1500-1-N

| Power | Range ft. | m | Size in | mm |
|-------|-----------|----|-----------------|------------------|
| USB | 100 | 30 | 7.0 x 5.5 x 2.5 | 178 x 140 x 63.5 |

ROUTER

Each DataSure Router extends the system's range in increments of 100 feet (30 meters). They ensure system robustness by providing alternate signal paths in noisy environments.

ROUTER FEATURES

- Range extender
- Transmits around interference
- Wall mount or mobile



1500-2-N

| Power | Range ft. | m | Size in | mm |
|----------|-----------|----|-----------------|------------------|
| AC, NiMH | 100 | 30 | 7.0 x 5.5 x 2.5 | 178 x 140 x 63.5 |



1500-3A-24N on 795.1



DataSure®

WIRELESS DATA COLLECTION

DATA SURE® SOFTWARE

DataSure Advanced Wireless Data Collection Software connects and manages your tools, network, data and third party SPC applications.

- Monitors your wireless network, tools, system status, end node battery voltages and tools measurements all from one screen
- Measurements can be initiated and viewed directly from the home page
- Data can be exported in CSV format
- Data is stored on a local or network database with programmable, scheduled backup
- Remote personnel can configure tools, export data and monitor activity via intranet with no additional software
- Virtual multiplexers allow data to be directed from specific tools to multiple software applications
- Each radio end node can be personalized with a descriptive name
- Drag and Drop tools on multiplexers
- Fast and easy label changes for tools
- Fast response for measurement
- System OS Requirements: Windows® 2000, XP Home and Pro with SP2, SP3, Vista SP1, Vista SP2, Windows® 7 32 bit, Windows® 7 64 bit, Windows® 8, Windows® 10
- Data can also connect directly to your SPC application via com port or DDE (Dynamic Data Exchange) link



781XTZ-2

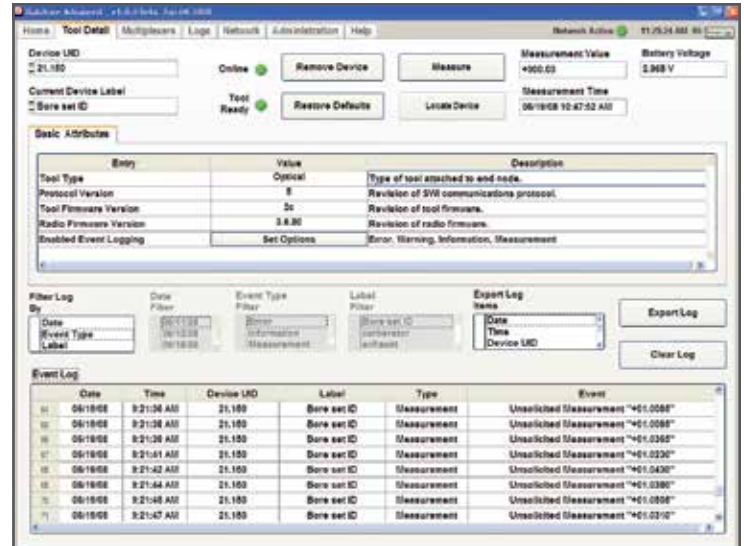

DataSure Advanced Wireless Data Collection Manager Software provides a powerful, intuitive interface and works well with many popular SPC applications.



DataSure® WIRELESS DATA COLLECTION

A wide variety of End Nodes are available, allowing DataSure to interface with electronic measuring tools from virtually all major manufacturers

ADDING DATA SURE® TO YOUR FACILITY

To add DataSure to your facility, simply contact us. We will work with you to specify a system for your application.

We will add new End Nodes and Output Connectors to those listed below as needed. Please call to discuss your requirements.

Note that new End Nodes or Routers for a current system must be made to match the Group Number of your existing components.



DataSure Gateway, Routers

| Cat. No. | EDP | Description |
|----------|-------|------------------------------------|
| 1500-1-N | 12051 | Gateway, USB, 917MHz |
| 1500-2-N | 12059 | Router, 916MHz, 120/240 VAC |
| PT62742 | 62024 | Gateway or Router Mounting Bracket |

DataSure End Nodes, Connectors and Accessories

| Cat. No. | EDP | Tool Type | Description |
|-------------|-------|--------------------------|---|
| 1500-3A-2N | 12531 | Micrometer | End Node, Starrett 795 Series |
| 1500-3A-3N | 12532 | Micrometer | End Node, Starrett 3rd Gen., 733 Style Micrometer Head |
| 1500-3A-9N | 12538 | Micrometer | End Node, Mitutoyo 500-6XX, 500-7XX Series |
| 1500-3A-10N | 12539 | Micrometer | End Node, Mitutoyo 293-2XX, 293-3XX Series |
| 1500-3A-24N | 72536 | Micrometer | End Node, Starrett 795.1 Series |
| 1500-3A-18N | 12565 | Micrometer/Slide Caliper | End Node, Starrett Proximity 770B Micrometers, 798 Calipers, and 781 3-Button |
| 1500-3A-1N | 12530 | Slide Caliper | End Node, Starrett Opto, 797 Series, 781 2-Button |
| 1500-3A-23N | 72662 | Slide Caliper | End Node, Starrett EC799 Slide Caliper |
| 1500-3A-7N | 12536 | Slide Caliper/Indicator | End Node, Mitutoyo with and without Absolute Encoder |
| 1500-3A-4N | 12533 | Indicator | End Node, Starrett 2700 Series |
| 1500-3A-21N | 00046 | Indicator | End Node, Starrett 2900 Series |
| 1500-3A-13N | 12542 | Indicator | End Node, Mitutoyo 543-5XX Series |
| 1500-3A-5N | 12534 | Other | End Node, Starrett Cat. No. 2000 Series |
| 1500-3A-15N | 12544 | Other | End Node, Starrett 782, 781, 797 Series, TESA-CAL, TESA Intramik |
| 1500-3A-6N | 12535 | Other | End Node, Mitutoyo 6-Pin Round |
| 1500-3A-8N | 12537 | Other | End Node, RS232, DB9 Tools with TX, RX, GND |
| 1500-3A-11N | 12540 | Other | End Node, Marposs E4N |
| 1500-3A-12N | 12541 | Other | End Node, Universal 10-pin connector |
| 1500-3A-14N | 12543 | Other | End Node, Mahr-Federal with µMaxum and XL |
| 1500-3A-16N | 12545 | Other | End Node, Mahr-Federal EX |
| 1500-3A-20N | 69854 | Other | End Node, TESA Microhite |
| PT62785-0 | 12188 | Accessory | Mushroom Head Fastener Kit to Attach End Nodes to Tool (Two pair included with each end node) |

DataSure Replacement Output Connectors

| Cat. No. | EDP | Tool Type | Description |
|-------------|-------|---------------|---|
| PT63298-2N | 12547 | Micrometer | Replacement Output Connector, Starrett 795 Series |
| PT63706-22N | 73325 | Micrometer | Replacement Output Connector, Starrett 780 Bore Gage |
| PT63473-24N | 73327 | Micrometer | Replacement Output Connector, Starrett 795.1 Series |
| PT63305-9N | 12554 | Micrometer | Replacement Output Connector, Mitutoyo 500-6XX, 500-7XX Series |
| PT63306-10N | 12555 | Micrometer | Replacement Output Connector, Mitutoyo 293-2XX, 293-3XX Series |
| PT63300-4N | 12549 | Indicator | Replacement Output Connector, Starrett 2700 Ind. |
| PT63536-21N | 73324 | Indicator | Replacement Output Connector, Starrett 2900 |
| PT63389-18N | 12562 | Slide Caliper | Replacement Output Connector, Starrett 798 Calipers, Proximity 781 3-Button |
| PT63660-23N | 12547 | Slide Caliper | Replacement Output Connector, Starrett EC799 Caliper |
| PT63297-1N | 12546 | Other | Replacement Output Connector, Starrett Opto, 797 Series, 781 2-Button |
| PT63299-3N | 12548 | Other | Replacement Output Connector, Starrett 3rd Gen., 733 Style Micrometer Head |
| PT63301-5N | 12550 | Other | Replacement Output Connector, Starrett 2000/2001/3752 Series |
| PT63302-6N | 12551 | Other | Replacement Output Connector, Mitutoyo 6-Pin Round |
| PT63303-7N | 12552 | Other | Replacement Output Connector, Mitutoyo without Absolute and with Absolute |
| PT63310-14N | 12559 | Other | Replacement Output Connector, Mahr Federal Umaxum Indicator |
| PT63312-16N | 12561 | Other | Replacement Output Connector, Mahr Federal Ex |
| PT63304-8N | 12553 | Other | Replacement Output Connector, RS232, DB9 Tools with TX, RX, GND |
| PT63307-11N | 12556 | Other | Replacement Output Connector, Digimatic W/D-Sub 9 Pin |
| PT63308-12N | 12557 | Other | Replacement Output Connector, Universal Mitutoyo 10 Pin |
| PT63309-13N | 12558 | Other | Replacement Output Connector, Absolute Digimatic |
| PT63311-15N | 12560 | Other | Replacement Output Connector, Opto/Duplex |
| PT63533-20N | 73320 | Other | Replacement Output Connector, TESA Microhite |



DataSure®

WIRELESS DATA COLLECTION

▲ DATA SURE® THROUGHPUT AND ACCURACY STUDY

In a controlled, 100% inspection test to measure the impact of DataSure on throughput and quality assurance, we made three measurements per part and recorded the data on 500 parts.

Methods 1 and 2 involve time-consuming hand movements to pickup and put down the tool in order to record data. Measurement with DataSure is fast and direct. The slowest method (#1) required 29 second per part with many errors. With DataSure® the same task was nearly 5 times faster – with no errors.

METHOD 1: MEASURE, HANDWRITE RESULTS, REMOTE DATA ENTRY

- 37 time/motion elements, 28.9 sec./part
- 62 entry errors

Factors affecting accuracy and throughput:

- Measurement must stop to handwrite results.
- Illegible handwritten numbers, mistakes noted but not corrected, data written in shorthand and inspector's handwriting misread by the transcriber
- Value can change when the inspector releases the micrometer
- Data entry errors at the PC



METHOD 2: MEASURE AND ENTER RESULTS TO PC

- 20 time/motion elements: 15.3 sec./part
- 4 data entry errors

Factors affecting accuracy and throughput:

- Alternating measuring and data entry caused errors
- Caliper not seated correctly when released to key-in data
- Missed data entry, incorrect keystrokes, entry to wrong cell



METHOD 3: MEASURE AND ENTER RESULTS DIRECTLY WITH DATA SURE

- 17 time/motion elements: 6.6 sec./part
- 0 entry errors

Factors affecting accuracy and throughput:

- Measurement technique is maintained
- No interpretation or memory errors
- Immediate, direct data entry eliminates errors



GAGE MULTIPLEXERS

7612 AND 7613 4-PORT GAGEMUX USB

FAST, SIMPLE AND FLEXIBLE

Starrett 4-port gage multiplexers make it fast and easy to connect multiple gages to a PC. Interface is through USB and USB keyboard outputs, as well RS232 ports.

With the 7612 GageMux, no software wedge or other intermediary software is required. The PC "sees" the connection from the 7612 as a keyboard. Simply, open any document on your computer that accepts input, position your cursor, then send the data from the tool. That data will be input at the cursor location.

The 7613 GageMux USB 4-port gage is similar to the 7612 except that it does not have the keyboard function. It requires the Starrett 719 Software Wedge or a similar product to input data into the PC.

From manufacturing methods and materials to a built-in, power-saving mode, the GageMux was designed to be an environmentally friendly product.

FEATURES AND SPECIFICATIONS

- 4 input ports
- Simple set-up, your PC automatically installs USB driver when GageMux is plugged into PC's USB port – does not require software configuration
- Supports USB 2.0, RS232 and keyboard output
- Operating modes: Static (Normal) mode operation or Dynamic (MIN/MAX/TIR)
- Footswitch input, LED status light on each input, host command operation and set up

7612 and 7613 GageMux, Cables and Accessories

| Cat. No. | EDP | Description |
|----------|-------|---|
| 7612 | 69886 | GageMux 4 port, USB, RS232 and keyboard output; Includes USB cable and 110V AC power supply |
| 7613 | 69885 | GageMux 4 port, USB and RS232 includes USB cable and 110V AC power supply |

7612 and 7613 GageMux Cables

| Cat. No. | EDP | Description |
|-----------|-------|---|
| 795SCM | 69892 | Connect 795 Micrometer |
| 795.1SCM | 01124 | Connect 795.1 and 733.1 Micrometer |
| 733SCM | 69893 | Connect 733 Micrometer and 2600 Indicator |
| 798SCM | 69894 | Connect 798 Caliper |
| 797SCM | 69895 | Connect 797 Caliper |
| EC799BSCM | 46000 | Connect EC799B Caliper |
| 2000SCM | 69907 | Connect 2000 Height Gage |
| 2700SCM | 69896 | Connect 2700 Indicators |
| 2900SCM | 68751 | Connect 2900 Indicators |

7612 and 7613 GageMux Accessories

| Cat. No. | EDP | Description |
|----------|-------|--|
| 7612FTS | 69905 | Industrial Foot Switch with 6' cable |
| 7612PS | 69899 | 220/50 External Power Supply |
| 719 | 66490 | Software Wedge allows direct input to PC (7613 only) |



7612

719 SOFTWARE WEDGE™

Data collection software for serial devices. WinWedge captures data directly to Excel, Access or any Windows application or web page. It can even send commands out a COM port so you can control your device through hot keys, buttons, or DDE. Can also be used with any SCU style cable.



719 Software Wedge



SMARTCABLES™

SMARTCABLES

EASY TOOL-TO-PC CONNECTION AND DATA TRANSFER

SmartCable makes it fast and easy to connect a measuring tool to a PC. The interface provides the ability to connect through USB and USB keyboard outputs.

With the SmartCable keyboard output, no software wedge or other intermediary software is required. The PC "sees" the connection from the SmartCable as a keyboard. Simply, open any document on your computer that accepts input, position your cursor, then send the data from the tool. That data will be input at the cursor location.

With SmartCable USB output, requires 719 Software Wedge or a similar product to input the data to the PC.

From manufacturing methods and materials to a built-in, power-saving mode, the SmartCable was designed to be an environmentally friendly product.

FEATURES AND SPECIFICATIONS

- Simple Set-up, your PC automatically installs USB driver when the SmartCable is plugged into PC's USB port
- Supports USB 2.0, RS232 and Keyboard (optional) output
- Simple plug and play set up – doesn't require software configuration
- Operating modes: Static (Normal) mode operation or Dynamic (MIN/MAX/TIR)
- LED status light

| Smart Cable Products | | |
|----------------------|-------|--|
| Cat. No. | EDP | Description |
| 733SCU | 69898 | SmartCable USB Ouput for 733 Micrometer and 2600 indicator type output |
| 733SCKB | 69888 | USB cable to PC (In focused window) |
| 795SCU | 69897 | SmartCable USB Ouput for 795 Micrometer |
| 795SCKB | 69887 | USB cable to PC (In focused window) |
| 795.1SCU | 01126 | SmartCable USB Output for 795.1 and 733.1 Micrometer |
| 795.1SCKB | 01125 | USB cable to PC (In focused window) |
| 797SCKB | 69890 | USB cable to PC (In focused window) |
| 798SCKB | 69889 | USB cable to PC (In focused window) |
| EC799BSCU | 46002 | SmartCable to USB |
| EC799BSCKB | 46001 | USB cable to PC (In focused window) |
| 2000SCKB | 69908 | USB cable to PC (In focused window) |
| 2700SCKB | 69891 | USB cable to PC (In focused window) |
| 2900SCU | 68712 | SmartCable USB Output for 2900 |
| 2900SCKB | 68839 | USB cable to PC (In focused window) |
| 719 | 66490 | Software Wedge allows direct input to PC |
| PT26441 | 65893 | 2700 USB Connection |

| Direct RS232 9-Pin Connection Cables | | |
|--------------------------------------|-------|---|
| Part No. | EDP | For Use with Starrett Tool Numbers |
| PT61963 | 66636 | 714, 760, 786, 733, 762, 788, 749, 764, 790, 751, 769, 2600-1, 753, 773, 2600-4, 756, 777, 2600-8, 3752 |
| PT62425 | 67658 | 2000, 2001 |
| PT62606 | 68822 | 797B, 5000, 5001, 5002, 5003, 5004, 5005, 5006, 781; Opto Connection |
| PT63329 | 12732 | 798, USB Connection, 770B, 781B; Proximity Connection |

719 SOFTWARE WEDGE™

Data collection software for serial devices. WinWedge captures data directly to Excel, Access or any Windows application or web page. Send commands out a COM port so you can control your device through hot keys, buttons, or DDE. Works with all cables and DataSure.



719 Software Wedge



798SCKB



RS232 9-Pin Connection Cable





**GAGE AMPLIFIERS, HARDNESS
TESTERS, SURFACE TESTERS**

GAGE AMPLIFIERS

717 ELECTRONIC GAGE AMPLIFIER

Starrett has made electronic gaging easier with the 717 Electronic Gage Amplifier. The large analog display is easy to read and shows real-time change in measurements.

The 717 Gage Amplifier is flexible and has an accuracy within $\pm 2\%$ of full scale. Ranges vary from $\pm .010"$ to $\pm .0001"$ ($\pm 0.200\text{mm}$ to $\pm 0.002\text{mm}$), with gage graduations from $.0005"$ to $.000005"$ (0.01mm to 0.0001mm).

| | | |
|---------|-------|---|
| 717 | 67001 | Amplifier with Power Supply Charger |
| 715-1Z | 64479 | Lever-Type Gaging Head Range $\pm .010"$ (0.25mm) |
| 715-2Z | 64480 | Cartridge-Type Gaging Head Length 2-1/2" (64mm) Range $\pm .020"$ (0.50mm) |
| 715-6 | 64186 | Cartridge-Type Gaging Head Pneumatic-Push, Length 2-3/4" (70mm) Range $\pm .040"$ (0.100mm) |
| 715-7 | 64187 | Cartridge-Type Gaging Head Length 1-3/8" (35mm) Range $\pm .020"$ (0.50mm) |
| 715-8 | 64188 | Cartridge-Type Gaging Head Length 2-1/2" (64mm) Range $\pm .040"$ (0.100mm) |
| 715-9 | 64189 | Cartridge-Type Gaging Head Length 3-5/8" (92mm) Range $\pm .080"$ (0.200mm) |
| PT99441 | 52991 | Height Gage and Comparator Attachment 1/4 x 1/2" (6.3 x 13.5mm) (Adapts Gaging Heads to Height Gages, Magnetic Base Indicator Holders, Dial Comparators and Test Indicator Stands.) .375" (9.5mm) Snug Hole |
| PT60636 | 63839 | Power Supply Charger for USA and Canadian Configuration – 115/120 Volts/60 Cycle |
| PT99353 | 66456 | Power Supply Charger for United Kingdom Configuration – 100-240 VAC, 47-63Hz |
| PT99340 | 66455 | Power Supply Charger for European Configuration – 100-240 VAC, 47-63Hz |
| PT60642 | 72499 | Cable to Computer (9-Pin to 9-Pin) |
| 728-3 | 66662 | Shop Floor Pro™ Software |
| 719 | 66490 | Software Wedge™ Program for Interfacing to Spreadsheets |

| Ranges/Graduations | |
|--------------------|----------------------|
| Range in | Each Gage Graduation |
| $\pm .010$ | .0005 |
| $\pm .002$ | .0001 |
| $\pm .001$ | .00005 |
| $\pm .0002$ | .00001 |
| $\pm .0001$ | .000005 |
| mm | |
| ± 0.200 | 0.01 |
| ± 0.100 | 0.005 |
| ± 0.020 | 0.001 |
| ± 0.010 | 0.0005 |
| ± 0.002 | 0.0001 |

FEATURES

- Dual inputs for cumulative/differential measurements
- Selectable inch or millimeter ranges
- Selectable digital or analog output
- Simple "push-button" calibration
- Mirrored gage display for parallax-free readability
- Rugged metal case can be used anywhere in the shop
- Uses standard Starrett lever and cartridge-type probes
- Remote zero using PC
- Front panel data send button
- Single and continuous data send modes
- Serial Data Output via front panel button, PC or optional foot switch

ACCURACY

- Within $\pm 2\%$ of full scale

POWER REQUIREMENTS

- 110 volt VAC/60Hz (AC adapter furnished)

DATA OUTPUT

- Digital: ASCII serial data
- Analog: $\pm 2.5\text{VDC}$ /Full scale

SIZE

- Dimensions: 9-1/4" Height x 5-1/2" Width x 5-1/2" Depth (235 x 140 x 140mm)
- Weight: 6 lb (2.7kg)



717 Electronic Gage Amplifier with 252 Transfer Gage and 715-1Z Gaging Head

GAGE AMPLIFIERS

RMS REMOTE DISPLAY

The Remote Display allows for the connection of up to four gages and displaying their current measurements into an Android application. In addition, the Remote Display can connect to up to two external data consumers (desktop computer, laptop, PLC, or any generic serial device) over RS-232 and USB.

The Remote Display has been designed to work with nearly any gauge that outputs data in Digimatic format. This includes all 2700 Indicators. In addition, devices that output raw quadrature can be used as well.

As a standalone measurement system, the Remote Display provides a very intuitive and user-friendly way to configure and monitor several gages at once. Connecting the Remote Display to a computer or other serial device makes data collection and statistical process control (SPC) simple and easy.

| Electronic Measurement System | | | | | | |
|-------------------------------|-------|---|-------|------------|------|----------|
| Cat No. | EDP | Description | | | | |
| RMS2704 | 72954 | RMS4 readout/data collection system with tablet, software MUX box | | | | |
| Probes | | | | | | |
| Cat No. | EDP | Description/Range | | Resolution | | AGD Size |
| | | in | mm | in | mm | |
| P27300-1 | 72955 | .060 | 1.5 | .0001 | .002 | 2 |
| P27300-0 | 72956 | .060 | 1.5 | .00005 | .001 | 2 |
| P27400-1 | 72957 | .150 | 3.8 | .0001 | .002 | 2 |
| P27400-0 | 72958 | .150 | 3.8 | .00005 | .001 | 2 |
| P27500-1 | 72959 | .250 | 6.35 | .0001 | .002 | 2 |
| P27500-0 | 72960 | .250 | 6.35 | .00005 | .001 | 2 |
| P27600-1 | 72961 | .600 | 15 | .0001 | .002 | 2 |
| P27600-0 | 72962 | .600 | 15 | .00005 | .001 | 2 |
| P27211-1 | 72963 | 1.0 | 25.4 | .0001 | .002 | 3 |
| P27211-0 | 72964 | 1.0 | 25.4 | .00005 | .001 | 3 |
| P27720-1 | 72965 | 2.0 | 50 | .0001 | .002 | RECT |
| P27820-1 | 72966 | 4.0 | 101.6 | .0001 | .002 | RECT |
| Accessories | | | | | | |
| Part No. | EDP | Description | | | | |
| PT05937 | 72967 | Push button remote global data send cable for MUX Box with 2.5mm plug | | | | |
| PT05679 | 68752 | 6' Extension Cable | | | | |

| Complementary Electronic Equipment | | |
|------------------------------------|-------|--|
| Cat No. | EDP | Description |
| EC799BSCM | 46000 | SmartCable Gage MUX - EC799B Slide Caliper |
| 798SCM | 69894 | SmartCable Gage MUX - 798 Slide Caliper |
| 795.1SCM | 01124 | SmartCable Gage MUX - 795.1 Micrometer |
| 733SCM | 69893 | SmartCable Gage MUX - 733 Micrometer |
| 2900SCM | 68751 | SmartCable Gage MUX - 2900 Indicator |
| 2700SCM | 69896 | SmartCable Gage MUX - 2700 Indicator |
| 2000SCM | 69907 | SmartCable Gage MUX - 2000-24 Height Gage |

| Backs/Lever* | | |
|--------------|-------|----------------------------------|
| Part No. | EDP | Description |
| PT26406 | 65886 | Flat Back |
| PT26407 | 65887 | Offset Lug Back |
| PT26411 | 65891 | Adjustable Lug Back |
| PT26408 | 65888 | Adjustable Back |
| PT26409 | 65889 | Post-Type Back |
| PT26410 | 65890 | Screw Bracket Back |
| PT26848 | 66293 | Adjustable Mounting Bracket Back |
| PT26405 | 65885 | Lifting Lever |

*Other backs, styles and accessories also available by request. To order contact points individually, see previous pages.

FEATURES

- 7" Android tablet with intuitive software application for easy process monitoring, setup, and data export
- Flexible data requesting and logging (.CSV to Micro SD Card, E-mail, PC transfer) with programmable auto logging and collection
- Simultaneous connection of up to four devices (Indicators, Calipers, Micrometers, Probes, etc.)
- Supports both Digimatic and Quadrature gaging systems
- "Send All" or "Request All" data to/from all gages
- TIR, Max., Min. and Freeze Hold, Travel Reverse
- USB Type A and B, RS232 connection
- High quality, low profile enclosure
- Bright LED power indication
- IN, MM and No Units setting
- Programmable Ratios
- Four channel view



RMS2704

NEW!

GAGE AMPS, HARDNESS AND SURFACE TESTERS



GAGE AMPLIFIERS

776 GAGE-CHEK™ MULTI-AXIS MEASURED VALUE DISPLAY

The Gage-Chek™ 776 is a multi-axis measured value display that accepts up to eight probe inputs. It features intuitive visual display, helpful audio cues and user-defined formulas. GAGE-CHEK also reports dynamic Min/Max measurements, provides SPC analysis from an integrated database, and includes connectivity to PCs and other Starrett tools.

| Specifications 776 Gage-Chek Multi-Axis Measured Value Display | |
|--|--|
| LCD | 6" color |
| Display Digit Size | .45" |
| Resolution Down To | .000004"/.0001mm |
| Operating Temperature | 32° - 115 °F |
| Enclosure (W x H x D) | 11.5 x 7.5 x 2.75" |
| Base Width (W x H x D) | 10 x 2 x 7.5" |
| Enclosure Weight | 3.5 lbs |
| Base Weight | 7 lbs |
| Input Voltage Range | 85 VAC - 264 VAC |
| Input Frequency | 43 Hz - 63 Hz |
| Inputs | 1-, 4- and 8-axis input available |
| External Connections | Foot Switch, Remote Keypad, Touch Probe, RS232C Serial Port, Parallel Port |
| Outputs | 2 Relay Outputs |

FEATURES

- Large (6") color flat-panel LCD screen built into a compact ergonomically designed case with an adjustable tilt base allows comfortable positioning for the operator
- Supports 1, 4 or 8 input channels. These can be mathematically combined to display dimensions such as flatness, volume or runout.
- Screens include individual readings with the capacity to display four lines simultaneously (each line 9/16" high), bar and dial position style displays, graphs and histograms of measurement statistics, and tables of measurement and SPC data
- Supports Starrett 776 LVDT probes and Heidenhain Spectro style 12mm and 30mm range digital probes
- Measurements can be taken by the operator or in a semi-automated manner
- Large comfortable buttons allow easy selection of measurement functions, display screen changes, data entry and zeroing the screen
- Speaker and external jack outputs can be adjusted to compensate for noisy work environments. Earphones can be plugged into speaker jack for silent operation.
- Two 3 x 1/2" keys placed over the screen can be programmed as hot keys for frequently used functions
- Optional foot switch available



776



The 776 accepts multiple gage inputs simultaneously – invaluable for applications such as this Starrett special gage fixture



776 LVDT Probes



715-2Z



715-7



715-8



715-9

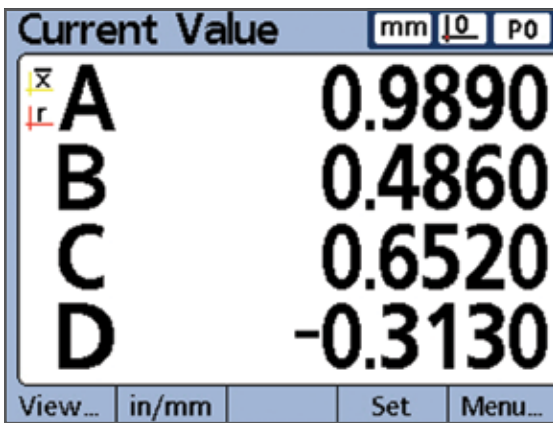

DRO View: Gage-Chek™ 776 features large, easy-to-read numerical display with custom dimension labels. Out of tolerance conditions are quickly identified by a change to red. Icons indicate that a process study has been performed, complete with in/out of tolerance alert. Mode switches include inch/metric, absolute/incremental, decimal degree/degrees, minutes, seconds.

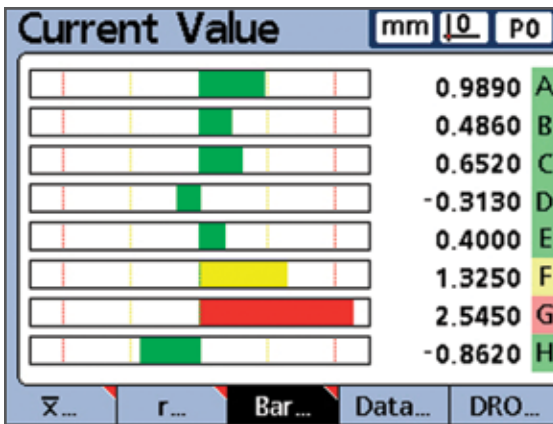

Displays all gages plugged into the gage chek at one time. It automatically displays marginal and error indications with multi-color display.

776 Gage-Chek Multi-Axis Measured Value Display

| Cat. No. | EDP | Description |
|----------|-------|--|
| 776A | 68635 | Gage-Chek – 140-SP with 4 Inputs, Specto |
| 776B | 68636 | Gage-Chek – 180-SP with 8 Inputs, Specto |
| 776C | 68761 | Gage-Chek – 110-ST with 1 Input, LVDT |
| 776D | 68762 | Gage-Chek – 140-ST with 4 Inputs, LVDT |
| 776E | 68763 | Gage-Chek – 180-ST with 8 Inputs, LVDT |
| 719 | 66490 | Software Wedge RS232 for Windows |
| PT99530 | 68637 | Two-Function Foot Switch |
| PT62514 | 68638 | Eight-Function Remote Keypad |
| PT62515 | 68639 | Gage-Chek Instruction Manual |
| 776-12 | 68640 | .472" (12mm) Length Probe, Specto |
| 776-12R | 68796 | .472" (12mm) Length Probe Radial Exit, Specto |
| 776-30 | 68641 | 1.180" (30mm) Length Probe, Specto |
| 776-30R | 68797 | 1.180" (30mm) Length Probe Radial Exit, Specto |
| PT05713 | 68172 | 9.849" (3 meter) Extension Cable for Specto Probe |
| PT05727 | 68773 | 32.89" (10 meter) Extension Cable for Specto Probe |
| 776-1Z | 68817 | ±.010" (0.25mm) Lever Type Probe, LVDT |
| 776-2Z | 68818 | ±.020" (0.50mm) Traditional Probe, LVDT |
| 776-7 | 68819 | ±.020" (0.50mm) Short Probe, LVDT |
| 776-8 | 68820 | ±.040" (0.100mm) Probe, LVDT |
| 776-9 | 68821 | ±.100" (2.54mm) Probe, LVDT |
| PT05414 | 68828 | 6' (1.82 meter) Extension Cable for LVDT |
| PT05415 | 68829 | 13' (4.5 meter) Extension Cable for LVDT |



Heidenhain Specto Length Probes



GAGE AMPLIFIERS

715 ELECTRONIC GAGE AMPLIFIER GAGE HEADS

715-1Z LEVER-TYPE HEAD

- Mounts directly in place of dial indicators with dovetail or AGD lug-type backs
- .078" (2mm) diameter contact standard .031" (0.8mm) and .062" (1.6mm)
- Diameter carbide contacts are available

715-2Z* CARTRIDGE-TYPE HEADS

- Hardened steel contact with radius tip. Head will accept all standard AGD contact points.
- .375" (9.5mm) mounting diameter allows replacement of standard AGD dial indicators

715-6, 715-7, 715-8, AND 715-9 CARTRIDGE-TYPE HEADS

- Tungsten carbide ball contacts
- Head will accept any AGD style contact**
- Half-bridge construction, stainless steel body
- .375" (9.5mm) mounting diameter allows replacement of standard AGD dial indicators



715-1Z

715 Electronic Gage Amplifier Gage Heads

| Cat. No. | EDP | Spindle Range | Length | Contact Pressure |
|----------|-------|---------------------------------|---------------|------------------|
| 715-1Z | 64479 | ±.010" (0.25mm) measuring range | | 8-12 grams |
| 715-2Z* | 64480 | ±.020" (0.50mm) | 2-1/2" (64mm) | 25-35 grams |
| 715-6 | 64186 | ±.040" (1.02mm) | 2-3/4" (70mm) | 70 grams |
| 715-7 | 64187 | ±.020" (0.51mm) | 1-3/8" (35mm) | |
| 715-8 | 64188 | ±.040" (1.02mm) | 2 -/2" (64mm) | |
| 715-9 | 64189 | ±.080" (2.03mm) | 3-5/8" (92mm) | |

715-1Z, -2Z, -6, -7, -8, -9 Gaging Heads come with a 6' (1.8m) cable and male connector.

* Longer range cartridge-type gaging heads are available, quoted on application.

** 715-9 head will accept all standard AGD contacts.



715-2Z



715-6



715-7



715-8



715-9



BENCH HARDNESS TESTERS

3814 ANALOG BENCH HARDNESS TESTER

The 3814 Hardness Tester provides reliable Rockwell Hardness values on all types of metal and alloys, hard or soft, and in many shapes. This reliable bench hardness tester has a high quality casting, is ergonomically designed for easy operation and is engineered to ensure accurate results. It is an ideal basic hardness solution, economically priced to suit a variety of lab, workshop, toolroom and inspection department applications. The 3814 conforms to ASTM E-18 standard. The tester is furnished with a diamond indenter, a 1/16" (1.6mm) ball indenter, three certified test blocks, four test tables – 5.87" (149mm) and 2.5" (63.5mm) flat anvils, 5/8"(15.9mm) spot anvil and a standard vee anvil – and an accessory case.

3814 Hardness Testers

| Cat. No. | EDP | Description |
|----------|-------|-----------------------------|
| 3814 | 67754 | Analog hardness tester |
| 3814E | 72974 | Digital readout replacement |
| PT06145 | 72519 | Hardness tester stand |

Specifications

| | |
|--------------------------------|------------------------------------|
| Minor Load | 10Kgf |
| Major Load | A: 60Kgf, B: 100Kgf, C: 150Kgf |
| Test Force Application | (Dead weight applies test force) |
| Test Force Control | Hydraulic Dashpot System |
| Results Display | Analog – Dial Gage |
| Throat Depth | 6.6" (168mm) |
| Maximum Test Height | 6.69" (169.9mm) * |
| Unit Height/Width/Depth | 30 x 8.5 x 20" (762 x 216 x 508mm) |
| Unit Weight | 261lb (118kg) |

* Requires bench alteration.

FEATURES

- Ability to handle Rockwell Scales A through H and K
- Stable cast iron construction
- Ideal basic hardness testing for many typical applications
- Digital readout available



NEW!

CASE /MP/5, HARDNESS AND SURFACE TESTERS



BENCH HARDNESS TESTERS

3815 TWIN ANALOG BENCH HARDNESS TESTER

MEASURES ROCKWELL & SUPERFICIAL ROCKWELL HARDNESS

The 3815 Twin Analog Hardness Tester features state-of-the-art design and rugged construction. It is engineered to provide highly sensitive, accurate readings and excellent repeatability in all Rockwell and Superficial Rockwell hardness scales.

The 3815 is ideal for heat treatment facilities, tool rooms, workshops, laboratories and inspection labs.

3815 Twin Analog Bench Hardness Tester

| Cat. No. | EDP | Description |
|----------|-------|--|
| 3815 | 12800 | 3815 Bench Hardness Tester, diamond conical and 1/16" ball indentors, HRC, HRB, HR15N, HR30N and HR45T test blocks, 5.87" (150mm) test table, 2.5" flat anvil, standard vee anvil, accessory case and dust cover |
| PT06145 | 72519 | Hardness Tester Stand |

A broad range of test blocks and other hardness tester accessories are available.

Specifications

| | |
|--------------------------|-----------------|
| Minor Load | 10 Kgf |
| Minor Load – Superficial | 3 Kgf |
| Major Load | 60/100/150 Kgf |
| Major Load – Superficial | 15/30/45 Kgf |
| Test Force Application | Dead Weight |
| Test Force Control | Manual |
| Results Display | Dual Scale Dial |
| Vertical Capacity | 6.0" (15.2mm) |
| Throat Depth | 5.5" (14mm) |
| Height | 26.0" (66mm) |
| Width | 18.2" (46.2mm) |
| Depth | 9.4" (23.9mm) |
| Weight | 250 lbs (113kg) |

FEATURES

- Direct analog dial reading
- Advanced design provides Rockwell and Rockwell Superficial testing
- Easy to operate
- Engineered to provide highly sensitive and accurate readings
- Conforms to ASTM E-18
- Tests Rockwell Scales: A, B, C, D, E, F, G, H, K, L, M
- Tests Superficial Rockwell Scales: HR15N, HR15T, HR30N, HR30T, HR45N, HR45Ts
- Includes a diamond conical indenter, 1/16" ball indenter, HRC, HRB, HR15N, HR30N and HR45T test blocks, 5.87" (150mm) test table, 2.5" (63mm) flat anvil, standard vee anvil, accessory case and dust cover



BENCH HARDNESS TESTERS

3816B Digital Motorized Bench Hardness Tester

The 3816B Bench Hardness Tester offers easy, fully automated testing procedures and provides highly sensitive and accurate readings. The 3816B measures the full regular Rockwell Scales according to ASTM and SAE guidelines and accommodates all types of hard or soft metals and alloys, in numerous configurations. The tester is furnished with a diamond indenter, a 1/16" (1.6mm) ball indenter, three certified test blocks, four test tables – 5.87" (149mm) and 2.5" (63.5mm) flat anvils, 5/8"(15.9mm) spot anvil and a standard vee anvil and an accessory case.

FEATURES

- Fully automated routines reduce operator involvement and speeds measurements
- Large touch screen display
- Programmable scale conversions, dwell times and sample counter
- Sample averaging is automatically calculated
- RS232C output
- Built in mini-printer for outputting readings
- USB output

| 3816 Hardness Testers | | |
|---|-------|-------------------------------------|
| Cat. No. | EDP | Description |
| 3816B | 72972 | Digital bench hardness tester |
| PT06145 | 72519 | Benchtop level stand for tester |
| Accessories* for 3816 Digital Bench Hardness Tester | | |
| Cat. No. | EDP | Description |
| PT05245 | 67944 | C Regular |
| PT05249 | 67948 | 1/16" (1.6mm) Ball Unit |
| PT05069 | 67897 | RA Test Block (Rockwell A Scale 80) |
| PT05059 | 67888 | RB Test Block (Rockwell B Scale 90) |
| PT05050 | 67879 | RC Test Block (Rockwell C Scale 63) |
| PT05272 | 67969 | Master Block Set, Rockwell C Scale |

* For additional listings of test blocks and accessories, refer to the following pages in this section.

| Specifications | |
|-------------------------|--------------------------------------|
| Minor Load | 10Kgf |
| Major Load | A: 60Kgf, B: 100Kgf, C: 150Kgf |
| Test Force Application | (Dead weight applies test force) |
| Test Force Control | Motorized |
| Results Display | Hi-def LCD digital readout |
| Throat Depth | 6.50" (165mm) |
| Maximum Test Height | 6.87" (175mm) ** |
| Unit Height/Width/Depth | 28 x 8.9 x 20.6" (711 x 226 x 523mm) |
| Unit Weight | 187 lb (85kg) |

** Requires bench alteration.



3816B



HARDNESS TESTING

TEST BLOCKS AND ACCESSORIES FOR HARDNESS TESTERS

Starrett blocks can be used to test Rockwell, Brinell or Vickers scales. They are available in steel, brass and aluminum. Each block is serialized, with a certificate detailing the environmental conditions used to test the block.

Actual readings are given, with the averages of these readings: min. reading, max reading and a repeatability figure. The blocks are calibrated according to ASTM E-18 standards, ANSI (NCSL) Z540-1, (ISO) 10012-1, ISO/IEC 17025 and Mil-std 45662A.

Starrett hardness test blocks are manufactured from square steel or brass plates, as opposed to the more common round bar stock. The use of the plate gives a more accurate and consistent surface for inspection. Metallurgical tests have proven that during the production of round bar stock, suspended carbides in the mix migrate to the center of the rod. The scientific name for this condition is carbide segregation and results in different readings being found in the center of a rod rather than at its outer edges. Some manufacturers remedy this situation by removing the centers from their blocks.

Hardness test blocks are designed to be used only on one side and the indents should be more than .010" from the centers of two indents or no closer to the block's edge than .040".

Calibration kits are also available from Starrett. No facility with a hardness tester in use should be without a calibration kit. These kits come with from 3 to 20 calibrated test blocks and the serialized penetrator that was used to inspect each of the blocks in the set. When a discrepancy is detected in a tester, these kits allow you to determine the direction to proceed to resolve the issue.

| Rockwell Test Blocks | |
|----------------------|------------------|
| Part No. | Description † |
| PT05050 | RC63 Test Block |
| PT05051 | RC60 Test Block |
| PT05052 | RC55 Test Block |
| PT05053 | RC50 Test Block |
| PT05054 | RC45 Test Block |
| PT05055 | RC40 Test Block |
| PT05056 | RC35 Test Block |
| PT05057 | RC30 Test Block |
| PT05058 | RC25 Test Block |
| PT05059 | RB90 Test Block |
| PT05060 | RB80 Test Block |
| PT05061 | RB70 Test Block |
| PT05062 | RB60 Test Block |
| PT05063 | RB50 Test Block |
| PT05064 | RB40 Test Block |
| PT05065 | RB30 Test Block |
| PT05067 | RB20 Test Block |
| PT05068 | RB10 Test Block |
| PT05069 | RA80 Test Block |
| PT05091 | RA70 Test Block |
| PT05092 | RA60 Test Block |
| PT05100 | RF100 Test Block |
| PT05101 | RF90 Test Block |
| PT05102 | RF80 Test Block |
| PT05103 | RF70 Test Block |
| PT05104 | RF60 Test Block |
| PT05105 | RF50 Test Block |
| PT05106 | RE100 Test Block |
| PT05107 | RE90 Test Block |
| PT05108 | RE80 Test Block |
| PT05112 | RE70 Test Block |
| PT05113 | RE60 Test Block |

† Values expressed are not exact but will range within acceptable limits

| Rockwell Test Blocks | |
|----------------------|--------------------|
| Part No. | Description † |
| PT05114 | RE50 Test Block |
| PT05115 | HR30N80 Test Block |
| PT05122 | HG30N70 Test Block |
| PT05123 | HR30N60 Test Block |
| PT05124 | HR30N50 Test Block |
| PT05125 | HR30N40 Test Block |
| PT05127 | HR30T80 Test Block |
| PT05128 | HR30T70 Test Block |
| PT05129 | HR30T60 Test Block |
| PT05130 | HR30T50 Test Block |
| PT05177 | HR30T40 Test Block |
| PT05178 | HR30T30 Test Block |
| PT05179 | HR30T20 Test Block |
| PT05180 | HR30T10 Test Block |
| PT05181 | HR15N90 Test Block |
| PT05182 | HR15N80 Test Block |
| PT05183 | HR15N70 Test Block |
| PT05184 | HR15T90 Test Block |
| PT05185 | HR15T80 Test Block |
| PT05186 | HR15T70 Test Block |
| PT05187 | HR15T60 Test Block |
| PT05188 | HR45T70 Test Block |
| PT05189 | HR45T60 Test Block |
| PT05191 | HR45T50 Test Block |
| PT05192 | HR45T40 Test Block |
| PT05193 | HR45T20 Test Block |
| PT05194 | HR45T10 Test Block |
| PT05195 | HRH90 Test Block |
| PT05196 | HRH80 Test Block |
| PT05197 | HRR120 Test Block |
| PT05198 | HR30Y Test Block |
| PT05199 | HRM Test Block |
| PT05200 | HR15W Test Block |

† Values expressed are not exact but will range within acceptable limits

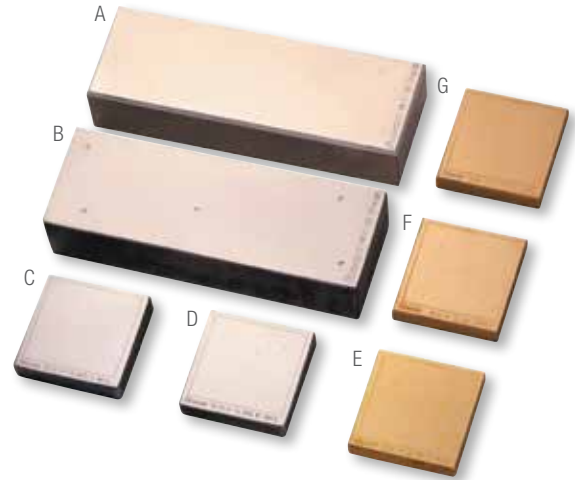

Rockwell and Brinell test blocks at a variety of hardness levels. (A) Aluminum Brinell, (B) Steel Brinell, (C) Vickers, (D) Rockwell, (E) 187.5kg/2.5mm Brinell, (F) Extra-Soft Rockwell and (G) Brass Rockwell.



HARDNESS TESTING

TEST BLOCKS AND ACCESSORIES FOR HARDNESS TESTERS

| Brinell Test Blocks | | |
|---------------------|-------|--------------------------------|
| Part No. | EDP | Description |
| PT05257 | 67956 | 3000kg High Brinell Test Block |
| PT05258 | 67957 | 3000kg Low Brinell Test Block |
| PT05259 | 67958 | 500kg High Brinell Test Block |
| PT05260 | 67959 | 500kg Low Brinell Test Block |

| Master Calibration Kits | | |
|-------------------------|-------|--|
| Part No. | EDP | Description |
| PT05272 | 67969 | HRC 3-Block Master Calibration Kit |
| PT05273 | 67970 | HR30N 3-Block Master Calibration Kit |
| PT05276 | 67971 | HRB 3-Block Master Calibration Kit |
| PT05277 | 67972 | C&B Scale 20-Block Master Calibration Kit |
| PT05278 | 67973 | C&30N Scale 6-Block Master Calibration Kit |



PT05272 HRC 3-Block Master Calibration Kit



| Anvils and Table | | | |
|------------------|----------|-------|------------------------|
| Letter | Part No. | EDP | Description |
| A | PT05267 | 67964 | Pedestal Anvil |
| B | PT05268 | 67965 | 2-1/2" Flat Anvil |
| C | PT05269 | 67966 | Small "V" Anvil |
| D | PT05270 | 67967 | Large "V" Anvil |
| E | PT05271 | 67968 | 8" Anvil Testing Table |

Standard and special anvils

| Penetrators | | | |
|-------------|----------|-------|---|
| Letter | Part No. | EDP | Description |
| E | PT05245 | 67944 | C Regular, No Thread |
| E | PT05246 | 67945 | Indentron with Internal Thread |
| G | PT05247 | 67946 | Versitron/New Age with External Thread |
| E | PT05248 | 67947 | N Regular, No Thread |
| D | PT05249 | 67948 | 1/16" (1.6mm) Ball with Holder |
| C | PT05250 | 67949 | 1/8" (1.7mm) Ball Complete with Holder |
| B | PT05251 | 67950 | 1/4" (6.4mm) Ball Complete with Holder |
| A | PT05252 | 67951 | 1/2" (12.7mm) Ball Complete with Holder |
| | PT05253 | 67952 | 1/16" (1.6mm) Carbide Ball Only, with Certification |
| | PT05254 | 67953 | 1/8" (1.7mm) Carbide Ball, with Certification |
| | PT05255 | 67954 | 1/4" (6.4mm) Carbide Ball, with Certification |
| | PT05256 | 67955 | 1/2" (12.7mm) Carbide Ball, with Certification |
| | PT05261 | 67960 | Heavy Load 5kg, 110RV5 Vickers Test Block |
| F | PT05264 | 67961 | Heavy Load Indentor Vickers |
| | PT05265 | 67962 | Min. Brinell 2 1/2mm Ball |
| | PT05266 | 67963 | Min. Brinell Block 187 1/2kg, 2-1/2mm Ball |



Penetrators - Contact Starrett for more information





Includes base instrument, impact device D, calibrated test block, custom carry case, cleaning brush and operation manual

SPECIFICATIONS

- Accuracy: $\pm 0.5\%$ (referred to L=800)
- Repeatability accuracy: $\pm 4L$ units (L=Leeb)
- Measuring range: 200-960 HL
- For steel and cast steel, alloy tool steel, stainless steel, grey cast iron, spheroidal iron, cast aluminum, brass, bronze, wrought copper alloy
- Tool steel should be about 1" thick solid material or larger
- Operating temperature: 5-104 °F
- Dimensions: 5.96 x 2.938 x 1.270" (150 x 74 x 32mm)
- Weight: 8.6 oz. (245 grams)

FEATURES

- Leeb style tester designed for large, hard parts – load the impact body and place the impact device on your test piece
- Easy to use keypad operation – push the button to begin testing and obtain reading
- Auto identification of impact device
- Large LCD display with back light
- USB output
- Automatic conversions to Rockwell, Brinell, Vickers and Shore
- Automatic mean value as well as Min and Max values
- Uses two AA alkaline batteries with low power indicator
- Memory capacity (100 groups)
- Optional impact devices and special support rings

HARDNESS TESTERS

3811A COMPACT HARDNESS TESTER

The 3811A is a state of the art, digital portable hardness tester, designed to test the hardness of large, hard metal parts.

The 3811A combines fast test speeds with ample memory and output. It performs tests that easily convert to most popular hardness scales such as Rockwell, Brinell, Vickers and Shore.

This compact hardness tester is loaded with useful functions usually found only on high priced models.

3811A Hardness Tester and Accessories

| Cat. No. | EDP | Description |
|-------------|-------|---|
| 3811A | 69881 | Digital portable hardness tester with impact device D, calibrated test block, cleaning brush and carry case |
| HT-1800-110 | 20940 | D+15 Impact Device |
| HT-1800-115 | 20941 | DL Impact Device |
| HT-1800-125 | 20942 | G Impact Device |
| HT-1800-130 | 20943 | C Impact Device |
| HT-1800-120 | 20944 | DC Impact Device |
| HT-1800-100 | 20945 | Replacement D Impact Device |
| HT-1800-102 | 20946 | Replacement Cable For All Impact Devices |
| HT-2500-105 | 20947 | Replacement Impact Body |
| HT-1300-01 | 20948 | Leeb D Test Block |
| HT-1100G-01 | 20949 | Leeb G Test Block |
| S38R | 67285 | Support Ring Set |

3811A Portable Hardness Tester with Integrated, Multi-functional Features

| Style | Applications |
|-------|---|
| D+15 | Very narrow contact area with a set backed measurement coil. Measures hardness in grooves and recesses. Weight: 80g |
| DC | Extremely short impact device. Used for very confined spaces such as, holes, cylinders and internal measurements |
| C | Reduced impact energy probe (2 ft-lb) for measuring hardness of coatings, surface hardened, thin wall or impact sensitive components. Applies superficial indentation. Weight: 75g |
| G | Enlarged test tip and increased impact energy range (72 ft-lb – approx. 9 times the D). For lower quality finishes measuring in the Brinell range only (max. 650 HB). Designed for components like heavy castings, forgings. Weight: 250g |
| DL | Needle front section with 4mm diameter and 50mm length. Ideal for testing in confined spaces, the base of grooves and special components like gear wheels. Steel/Cast steel |



Optional Remote Impact Devices



HARDNESS TESTERS

3810A DIGITAL PORTABLE HARDNESS TESTER

The 3810A is a state-of-the-art digital instrument designed to test the hardness of large hard metal parts. Loaded with useful functions such as USB output and a built in printer, the 3810A is an ideal choice for fast, accurate hardness testing.

This versatile tester can perform tests that easily convert to the most popular hardness scales, including Rockwell, Brinell, Vickers and Shore.

The tester is easy to use. Simply load the impact body, place the impact body on your test piece, then push the button to begin testing.

The 3810A is designed to test large hard parts that cannot be brought to a bench top machine. For example, tool steel should be close to 1" thick of solid material. The 3810A comes with a D impact device, calibration block, cleaning brush, manual and a carrying case.



SPECIFICATIONS

- Accuracy: $\pm 0.5\%$ (referred to L=800)
- Repeatability accuracy: $\pm 4L$ units (L=Leeb)
- Measuring range: 200-960 HL
- Materials: steel & cast steel, alloy tool steel, stainless steel, grey cast iron, spheroidal iron, cast aluminum, brass, bronze, wrought copper alloy
- Battery type: AA alkaline (4)
- Operating temperature: 5-104 °F
- Dimensions: 150 x 74 x 32mm
- Weight: 245 grams
- Includes 3810A tester, impact device D, calibration test block, cleaning brush, operation manual, custom carry case
- Available options include DC, D+15, DL, G, C impact devices, and special support rings

FUNCTIONS

- Easy to use keypad operation
- Auto identification of impact device
- Large LCD display with back light
- USB output
- Automatic conversions to: Brinell, Rockwell B & C, Vickers and Shore
- Automatic mean value as well as Min & Max values
- Battery indicator
- Memory capacity (100 groups)

3810A Hardness Tester and Accessories

| Cat. No. | EDP | Description |
|-------------|-------|---|
| 3810A | 69871 | Tester, D impact device, calibration block, cleaning brush, operation manual, custom carry case |
| HT-1800-110 | 20940 | D+15 impact device. Very narrow contact area with set backed measurement coil. Measures hardness in grooves and recesses. |
| HT-1800-115 | 20941 | DL impact device. Needle front section with 4mm diameter and 50mm length. For testing in confined spaces such as groove bases and special components such as gear wheels. |
| HT-1800-125 | 20942 | G impact device. For components such as heavy castings and forgings. Enlarged test tip and increased impact energy range. For lower quality finishes measuring in the Brinell range only. G block required. |
| HT-1800-130 | 20943 | C impact device. Reduced impact energy probe for measuring hardness of coatings and surface hardened, thin wall or impact- sensitive components. Applies superficial indentation. |
| HT-1800-120 | 20944 | DC impact device. Very short for confined areas such as internal bores for various inside measurements. |
| HT-1800-100 | 20945 | Replacement D impact device. Universal standard probe for a wide variety of applications. |
| HT-1800-102 | 20946 | Replacement cable for all impact devices |
| HT-2500-105 | 20947 | Replacement impact body D |
| HT-1300-01 | 20948 | Leeb D test block |
| HT-1100G-01 | 20949 | Leeb G test block |
| S38R | 67285 | Support ring set |



3810A



HARDNESS TESTERS

TECHNICAL DATA FOR STARRETT HARDNESS IMPACT DEVICES

| Technical Data for Impact Devices | | D/DC/DL | D+15 | C | G |
|-------------------------------------|--------------------------|------------------|------------------|------------------|------------------|
| Impact Energy | | 11 Nmm | 11 Nmm | 3 Nmm | 90 Nmm |
| Mass of the Impact Body | | 5.5g | 7.8g | 3.0g | 20g |
| Test Tip | Hardness | 1600 HV | 1600 HV | 1600 HV | 1600 HV |
| DL: 7.3 g | Diameter | 3mm | 3mm | 3mm | 5mm |
| | Material | Tungsten carbide | Tungsten carbide | Tungsten carbide | Tungsten carbide |
| | Impact Device | Diameter | 20mm | 20mm | 20mm |
| | Length | 147/86mm | 162mm | 141mm | 254mm |
| | Weight | 75/50 g | 80 g | 75 g | 250 g |
| | Max. Hardness of Sample | 940 HV | 1000 HV | 650 HB | |
| Preparation of Surface | Roughness class ISO | N7 | N7 | N5 | N9 |
| | Max. roughness depth Rt | 10µm | 10µm | 2.5µm | 30µm |
| | Average roughness Ra | 2µm | 2µm | 0.4µm | 7µm |
| Min. Weight of Sample | Of compact shape | 5kg | 5kg | 1.5kg | 15kg |
| | On solid support | 2kg | 2kg | 0.5kg | 5kg |
| | Coupled on plate | 0.1kg | 0.1kg | 0.02kg | 0.5kg |
| Min. Thickness of Sample | Coupled | 3mm | 3mm | 1mm | 10mm |
| | Min. thickness of layers | 0.8mm | 0.8mm | 0.2mm | — |
| Indentation of Test Tip with 300 HV | Diameter | 0.54mm | 0.54mm | 0.38mm | 1.03mm |
| | Depth | 24µm | 24µm | 12µm | 53µm |
| Indentation of Test Tip with 600 HV | Diameter | 0.45mm | 0.45mm | 0.32mm | 0.90mm |
| | Depth | 17µm | 17µm | 8µm | 41µmC |
| Indentation of Test Tip with 800 HV | Diameter | 0.35mm | 0.35mm | 0.30mm | — |
| | Depth | 10µm | 10µm | 7µm | — |

APPLICATION AND HARDNESS RANGES FOR STARRETT HARDNESS IMPACT DEVICES

| Optional Impact Devices | | | | | |
|---|-----------|-----------|---------|--------|-----------|
| Material | HRC | HRB | HB | HV | HSD |
| Impact Device – D, DC Measuring Range 200-900† | | | | | |
| Steel | 20.0-67.9 | 59.6-99.5 | 80-647 | 80-940 | 32.2-99.5 |
| C.W. Tool Steel | 20.4-67.1 | | | 80-898 | |
| Gray Cast Iron | | | 93-334 | | |
| Nodular Cast Iron | | | 131-387 | | |
| Cast Aluminum | | | 30-159 | | |
| Brass | | 13.5-95.3 | 40-173 | | |
| Bronze | | | 60-290 | | |
| Copper | | | 45-315 | | |
| Impact Device – D+15, Measuring Range 300-900† (not shown) | | | | | |
| Steel and Cast Steel | 19.3-67.9 | | 80-638 | 80-937 | 33.3-99.3 |
| Impact Device – C, Measuring Range 350-950† | | | | | |
| Steel and Cast Steel | 20.0-69.5 | | 80-683 | 80-996 | 31.9-99.6 |
| Impact Device – G, Measuring Range 300-750† | | | | | |
| Steel and Cast Steel | | 47.7-99.9 | 90-646 | | |
| Gray Cast Iron | | | 92-326 | | |
| Nodular Cast Iron | | | 127-364 | | |
| Impact Device – DL, Measuring Range 300-900† | | | | | |
| Steel and Cast Steel | 20-68 | 37-100 | 80-650 | 80-940 | 30-97 |

† Leeb Measuring Range



ROUGHNESS TESTERS



NEW!

SURFACE ROUGHNESS TESTERS

SR160, SR300 AND SR400

The SR160 is the latest to join a line of unique equipment to compliment the SR300 and SR400. Starrett surface roughness testing equipment is simple, accurate and of high quality. These units are tough, shock tested, and capable of withstanding the demands of a shop environment. Our surface roughness testers meet the increasing requirements across industries like safety, aerospace, automotive, precision bearings, and general manufacturing.



SR300/SR400

Surface Roughness Testers

| Cat. No. | EDP | Description |
|----------|-------|--|
| SR160 | 72584 | SR160 display with 5mm traverse unit, pick-up, diamond stylus, calibration standards, manual, carrying case, and international power adaptors. |
| SR300 | 21000 | SR300 display with 17.5mm traverse unit, TalyProfile Lite software, pick-up, diamond stylus, calibration standard, manual and carrying case. |
| SR400 | 21001 | SR400 display with 25mm traverse unit, TalyProfile Lite software, pick-up, diamond stylus, calibration standard, manual and carrying case. |

Accessories - SR160

| Cat. No. | EDP | Description |
|-------------|-------|--------------------------|
| SR-112-3188 | 72667 | Magnetic base |
| SR-112-4545 | 20220 | USB charger |
| SR-112-5085 | 72666 | Hard transport case |
| SR-112-2937 | 20968 | Extra reference standard |

Accessories - SR300 and SR400

| Cat. No. | EDP | Description |
|-------------|-------|----------------------------------|
| SR-112-1534 | 20962 | Reference standard |
| SR-112-2693 | 20964 | Column and stand |
| SR-112-4545 | 20220 | USB charger |
| SR-112-1517 | 20963 | Support stand |
| SR-112-4570 | 20998 | USB thermal printer |
| SR-112-4571 | 20999 | Thermal paper |
| SR-112-1645 | 73033 | Pair of 115mm (5.85") vee blocks |
| SR-112-2694 | 73036 | Precision vise |
| SR-112-2695 | 73037 | Ball joint vise |

Software

| Cat. No. | EDP | Description |
|-------------|-------|----------------------------------|
| SR-112-3680 | 20952 | TalyProfile Gold - 2D analysis |
| SR-112-3681 | 20953 | TalyProfile Silver - 2D analysis |

Parameters

| Cat. No. | EDP | Description |
|-------------|-------|--|
| SR-112-4607 | 73038 | AN-10 ISO 13565 automotive parameters for S116 |
| SR-112-4608 | 73039 | AN-11 statistics module for S116 |
| SR-112-4609 | 73040 | AN-12 ISO primary parameter set for S116 |

Pick-Ups

| Cat. No. | EDP | Description |
|---------------|-------|---|
| SR-112-1510 | 20961 | 7.875" (200mm) extension rod with lead |
| SR-112-1502 | 20956 | Standard pick-up with 200µin (5µm) stylus |
| SR-112-1503 | 20957 | Standard pick-up with 400µin (10µm) stylus |
| SR-115-P28495 | 21004 | Small bore pick-up |
| SR-112-1505 | 20959 | Right angle pick-up |
| SR-112-1506 | 20960 | Recess pick-up |
| SR-112-1524UB | 73028 | Pick-up with chisel edge stylus |
| SR-112-1525 | 73029 | Pick-up lift mechanism |
| SR-112-1531UB | 73030 | Pick-up with slide skid |
| SR-112-1599UB | 73032 | Pick-up with shoe |
| SR-112-2672UB | 73034 | Recess pick-up (2µm, 80µin, tip radius) |
| SR-112-2673UB | 73035 | Small bore pick-up (2µm, 80µin, tip radius); SR-112-4701 is preferred |
| SR-112-4707 | 73041 | O-Ring pick-up |
| SR-112-4708 | 73042 | 25mm recess pick-up |
| SR-112-4709 | 73043 | 15mm recess pick-up |
| SR-12-4710 | 73044 | O-Ring pick-up narrow |
| SR-112-4712 | 73046 | O-Ring pick-up; deep 25mm |
| SR-112-4713 | 73047 | O-Ring pick-up; deep 25mm with 2µm tip |
| SR-112-4714 | 73048 | Flat skid pick-up |
| SR-112-4715 | 73049 | Standard 112/1502 pick-up with 2.5µm tip |
| SR-112-4716 | 73050 | Side skid pick-up 112/1531 with 2µm tip |

All accessories listed above are available for order. Please contact your local Starrett representative for additional or special requirements.



SR160

CASE / MP3, HARDNESS AND SURFACE TESTERS



ROUGHNESS TESTERS

TALYPROFILE

ADVANCED SURFACE FINISH ANALYSIS

TalyProfile is a dedicated PC based software package designed for use with the SR300 and SR400 instruments. Three versions are available. TalyProfile "Lite" has all functions typically used for a shopfloor inspection. TalyProfile "Silver" has enhanced features for R&W parameters, a statistics module and full report printing. TalyProfile "Gold" has complete laboratory analysis functions.

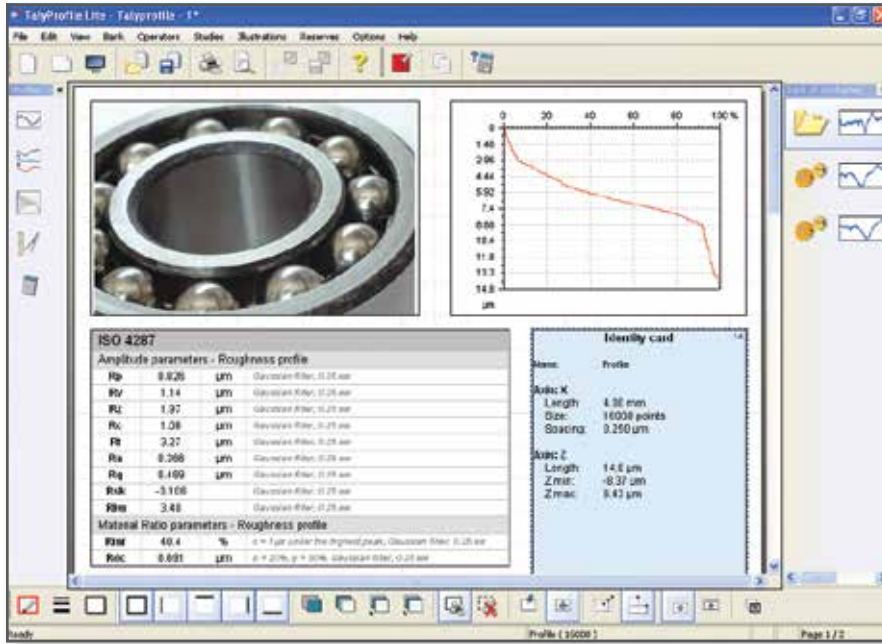

| TalyProfile | Lite | Silver | Gold |
|--------------------------------|------|--------|------|
| Surtronic S-series acquisition | x | x | x |
| Desktop publishing templates | x | x | x |
| Multi-language support | x | x | x |
| EN, FR, DE, ES, IT, PL, CN, KR | x | x | x |
| Leveling | x | x | x |
| Symmetries | x | x | x |
| Zoom | x | x | x |
| ISO 4287 | x | x | x |
| Material Ratio Curve | x | x | x |
| Area of a hole/peak | x | x | x |
| Profile parameters and curves | x | x | x |
| Roughness and waviness curves | x | x | x |
| Distance measurement | x | x | x |
| Multiple file format reports | | x | x |
| Report printing | | x | x |
| Form Talsurf data import | | x | x |
| Tolerance limits (pass/fail) | | x | x |
| Data file explorer | | x | x |
| ISO 13565 Automotive | | x | x |
| Interactive Mr curve | | x | x |
| Step height measurement | | x | x |
| Form removal | | | x |
| Filtering by FFT | | | x |
| Thresholding | | | x |
| Frequency spectrum | | | x |
| Power spectrum density | | | x |
| Retouch profile point | | | x |
| Rk parameters | | | x |
| Rk parameters curves | | | x |
| ISO 12085 R&W motifs | | | x |

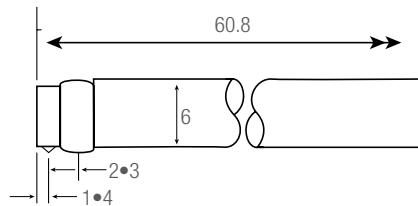

Standard Pick-Up
for general surface roughness measurement
Code SR-112-1502 (5µm tip radius)
Code SR-112-1503 (10µm tip radius)

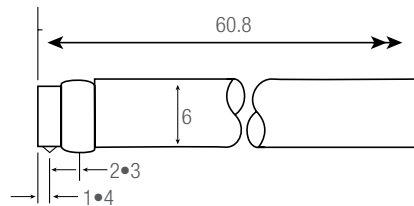

Right Angle Pick-Up
for measurement at right angles to the direction of traverse
Code SR-112-1505

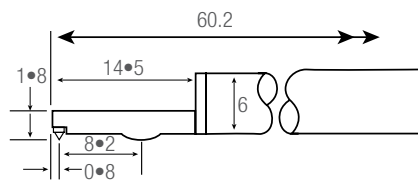

Small Bore Pick-Up
for general use in small bores, grooves and on narrow surfaces
Code SR-155-P28495

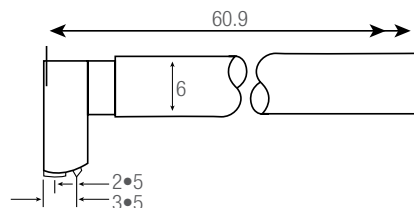

Recess Pick-Up
for measuring into deep recess
Code SR-112-1506 recess 5.7mm (0.23")

TALYPROFILE PARAMETERS

Roughness parameters obtained by filtering:
Ra, Rq, Rt, Rp, Ry, Rku, Rsk, RSm, Rz, RΔq, RTp, RHTp, Rlo, RPC, RzJIS, R3z

Parameters on the raw profile (unfiltered): Pa, Pq, Pt, Pp, Pv, Pku, Psk, PSm, Pz, PΔq, PTP, PHTp, PLo, PPc

Parameters obtained by double filtering (DIN 4776): Rk, Rpk, Rvk, MR1, MR2, A1, A2, Rpk,

Parameters obtained by the motifs method ("R&W"): R, AR, Pt, Rx, SR, SAR, Nr, Kr, W, AW, Wte, Wx, SW, SAW, Nw, Kw, Rke, Rpk, Rvke, Trc, HTrc

* Only with gold or silver versions

ELECTRONIC DUROMETERS

3805B ELECTRONIC DUROMETER

The 3805B meets ASTM D2240-05, "Standard Method For Rubber Properties - Durometer Hardness". It is designed to fit comfortably and firmly in your hand. Its large LED display and simple three button control make the 3805B Durometer easy to use.

The 3805B measures Shore A values for a wide variety of soft materials including: rubber: soft vulcanized (i.e. tire), natural nitrile; elastomeric materials (rubber and rubber-like): GR-S, GR-1, neoprene, thiokol, flexible polyacrylic esters; other softer materials including wax, felt, leather, etc. (materials that would normally yield under fingernail pressure).

FEATURES AND SPECIFICATIONS

- Meets ASTM standards for durometer hardness
- Extra large LED display
- Simple 3-button control
- Auto Hold feature
- Measuring range: 0-100 HSA
- Deviation: <1% H
- Resolution: 0.5 H
- Accurate and repetitive deviation = 20~90HSA
- HSA ± 1 grade
- Custom carrying case



| 3805B Electronic Durometer | | |
|----------------------------|-------|--|
| Cat. No. | EDP | Description |
| 3805B | 69882 | 3805B Electronic Durometer in plastic case |
| SRB-3 | 68200 | 3 Rubber Test Block Certified Set |



THICKNESS GAGES

3812 ULTRASONIC THICKNESS GAGE

The 3812 Ultrasonic Thickness Gage is a state-of-the-art digital ultrasonic thickness gage packed with features typically found only on high end models.

It measures the thickness of metallic and non-metallic materials such as steel, aluminum, titanium, plastics, ceramics, glass and any other good ultrasonic wave conductor that has parallel top and bottom surfaces.

This dynamic ultrasonic thickness gage accurately displays readings in either inch or millimeter units after a simple calibration to a known thickness or sound velocity.

3812 Ultrasonic Thickness Gage and Accessories

| Cat. No. | EDP | Description |
|-------------|-------|--|
| 3812 | 67668 | 3812 Ultrasonic Thickness Gage, software, USB cable, couplant gel and carry case |
| UTG2800-400 | 72686 | Replacement probe (straight) for 3812 |

FEATURES AND SPECIFICATIONS

- 4 digit LCD display with back light
- Upper/Lower limit preset alarm
- Measurement and scanning capabilities
- Adjustable sound velocity
- Extended memory
- 20 memory groups (100 files/group)
- Minimum display unit: 0.001" (0.01mm) selectable
- .040-12.0" measuring range (in steel with standard probe)
- 3280-32805ft/s (1000-9999m/s) sound velocity range
- 32-122 °F operating temperature
- 5MHz Frequency
- 4Hz update range
- USB output
- Power supply: Two 3V AA alkaline batteries with approximately 100 hours of life (with the backlight off)
- Power consumption: Working current is less than 3V
- Accuracy: \pm (0.5% thickness + .001")
- Dimensions: 5.90 x 2.91 x 1.30" (150 x 74 x 33mm)
- Weight: 8.6oz (245g)
- Includes tester and cables, software, USB cable, couplant gel and a rugged, form fit carrying case



3812



THICKNESS GAGES

3813 COATING THICKNESS GAGE

The 3813 Coating Thickness Gage is a state-of-the-art coating thickness gage that utilizes the characteristics of both eddy current and magnetic induction to perform two types of thickness calculation.

The gage uses an integrated probe to automatically determine whether the substrate is ferrous or non-ferrous. Then, it either detects the thickness of non-magnetic coating on a magnetic substrate (ferrous) or the insulating coating on a non-magnetic conductive substrate (non-ferrous).

Testing performance is non-destructive and extremely accurate. The 3813 is ideal for a broad range of applications in manufacturing, engineering and commercial inspection.

FEATURES AND SPECIFICATIONS

- Measuring range: 0-40mils (0-1000 μ m) max.
- Resolution: 0.1 μ m/0.1mils (0-99 μ m) or 1 μ m (over 100 μ m)
- Guaranteed tolerance (after one-point calibration): $\pm 1-3\%$ or 2 μ m (whichever is greater)
- 4-digit display, .40" (10mm) height,
- Minimum measuring area: .20 x .20" (5 x 5mm)
- Minimum radius of curvature: Convex: .12" (3mm), Concave: 1.2" (30mm)
- Minimum substrate thickness: Ferrous: 20 mils (0.5mm), Non-ferrous: 2 mils (50 μ m)
- Zero calibration
- Foil calibration
- Maximum surface temperature of test object: 302 °F (maximum contact time 2 seconds)
- Power source: Four AA batteries
- Includes steel and aluminum substrate samples
- Includes four calibrated thickness samples
- Dimensions: 6.39 x 2.74 x 1.27" (161 x 69 x 32mm)
- Weight: 9oz. (260g)

| 3813 Thickness Gage | | |
|---------------------|-------|---|
| Cat. No. | EDP | Description |
| 3813 | 69883 | Coating Thickness Gage with steel and aluminum substrate samples, four calibrated thickness samples, batteries, manual and case |





PRECISION MAKES THE DIFFERENCE

NO CONTACT IS THE SOLUTION.



Profile360™ is an in-line, real-time, non-contact solution for continuously monitoring key profile dimensions in complex shapes such as rubber, ceramic, plastic, and wood-plastic composite extrusions, roll-formed metal profiles, and profiled wire.



Starrett®

(978) 249-3551 • starrett.com

Follow us!





SPECIAL GAGING

SPECIAL GAGING

THE STARRETT SPECIAL GAGE DIVISION

Even with our extremely broad catalog of products, some application measurement requirements can not be met with a standard tool – they require a custom solution.

One way Starrett stands out from other precision tool providers is our willingness to work directly with our customers to develop custom tools and gages. Established over 50 years ago, our Special Gage Division is an independent group within the Company that devotes its total effort to developing and building special gages.

Once we determine that no "off-the-shelf" product is applicable, our engineers begin a dialog with the customer to develop a custom tool for the specific task.

Together, we discover what you want and need. Then, we design and build a special tool or gage that will perform to your expectations – with rugged construction, easy and intuitive operation, Starrett quality and guaranteed to meet your specifications for accurate, reliable part measurement.

Design work is treated in a strictly confidential manner. Design-and-build prices are quoted at no charge. Prices are fixed at order entry.

SINGLE-SOURCE RELIABILITY

We make and use electronic indicators, AGD dial, electronic and mechanical micrometer heads, and all of the other tools or gages that provide the output from the custom gage.

We also make DataSure® Wireless Data Collection Systems, which we have integrated into an increasing number of special gages so measurement data can be gathered and recorded with 100% reliability.

Simply put, our service and expertise are second to none – we control the entire process from concept through design, manufacture, inspection and delivery.

We offer the resources of this unique problem-solving division to innovate, design, and build the equipment you need to control product quality and reduce dimensional gaging costs.

The following pages show some examples of gages we have developed and built.



Custom designed and built
Area Flow Gage

SPECIAL GAGE DIVISION MISSION

We design and build dimensional measuring instruments that provide guaranteed performance to meet our customers' specifications. We are in the business of solving measuring problems when standard gages cannot be used.

Find out more about Starrett Custom Solutions at: starrett.com/custom

CONTACT US

We encourage you to contact us directly to discuss your application.

Tel.: (978) 249-3551 x407 | **FAX:** (978) 249-3699

E-mail: specialgage@starrett.com

The L. S. Starrett Company
Special Gage Division
121 Crescent Street
Athol, MA 01331-1915



Custom Height Gage with a
78.7" (2000mm) range and
resolution of .0005"



SPECIAL GAGING

MEASURING HOT STEEL DURING ROLLING, FORGING OR EXTRUDING

Starrett Special Gage was asked by a customer to develop a new gage for measuring hot steel flat stock during the rolling process.

The old measuring device utilized a gage with a crude fractional dial that did not provide accurate or repeatable results. In addition, it often stuck to the hot steel and ruined the piece being measured. Even worse, on several occasions, the old process caused burn injuries to the operator.

The customer needed a new solution that provided precise and reliable results, a much lower scrap rate, and ensured operator safety.

The application presented some unique challenges. Any operation that requires contact with hot steel is dangerous and must be of very brief duration.

FROM PROBLEM TO SOLUTION

After collaboration between the engineering staffs of our customer and the Starrett Special Gage group, a radically different gage was developed that met all of the design criteria.

THE HOT STEEL GAGE

- Takes measurements quickly, with only two seconds of contact
- Uses an electronic indicator with a hold feature to lock the reading so it can be safely read away from the dangerous area, and in better light conditions
- Nickel plated to minimize radiant heat transfer
- The operator's hand stays 12" away from the hot steel
- The gage is very accurate, measuring to $\pm .003$ "

A FAMILY OF GAGES

A number of satisfied companies are now using the Hot Steel Gage. Starrett has developed a family of related products with capacities up to 12" (in 1" or 3" increments) and 2' or 3' in-reach capacity. Other variations have modified jaws for measuring round stock.



The Hot Steel Gage is now a family of products with capacities up to 12"



Hot Steel Gage with a DataSure® End Node



Variation on a theme: A large caliper with long reach for web thickness of train tracks hot or cold.

DATA SURE® WIRELESS DATA COLLECTION

Starrett introduced the DataSure® Wireless Data Collection System several years after the hot steel gage was developed and it was a perfect fit for this application.

With DataSure®, the measurement data can be recorded and sent to a data collection application with 100% reliability immediately after it is recorded by the indicator.

Many manufacturers now include DataSure when they order these gages, and existing gages have been field-retrofitted.



SPECIAL GAGING

CONTAINER FIT MEASUREMENT FOR THE FOOD AND PLASTICS INDUSTRIES

PI-GAGES FOR I.D. AND O.D.

Starrett PI-Gages protect product quality by maintaining critical diameter tolerances of plastic lids and containers where shrinkage, temperature and mold affect parts manufacturing. The diameter of these parts is critical to the sealing integrity between lids and containers.

We have developed a wide variety of hand held and fixture gages for many related applications. Starrett PI-Gages measure most diameters accurately to within $\pm .001$.

Designed to measure any flexible circular part, variations of these gages have been in use for over 25 years, and have become the standard of the industry.



FIXTURES FOR LARGE O.D. OR I.D. MEASUREMENT



Metal band I.D. fixture for 1/2-gallon container



Master in position to set indicator to zero



Top of 1/2-gallon container in measuring position



PI-PLATE GAGE FOR O.D.

This gage ensures container quality requirements with an easy-to-use gage system. With either electronic indicators (and data collection), or dial indicators, this gage measures most product diameters to $\pm .001$ accuracy.

Each gage from the 2" to 4" range through the 10" to 12" range is set with the master. Push the button on the indicator to insert a part and release the button to gage a part within $\pm .025$ " diameter range from the master size. They provide quick changes from size-to-size, ease of use, and $\pm .001$ accuracy on most diameters will ensure process control.





PNEUMATIC FOOD TRAY MEASUREMENT

This gage measures width, length, and height of food trays. Full part length contacts ensure the correct dimensions for every measured parameter.

The gage employs a system of pneumatics to withdraw probes for quick, easy loading and unloading of trays.

A steel master is used to replicate a perfect part. The electronic indicators are then set to their mean values.

The result is a reliable and accurate system with fast throughput to measure a specialized, complex part.

MEASUREMENT OF THE INTERFACE OF A COFFEE CUP AND LID

Most of us have heard the story – a large fast food chain is sued because the lid came off of a Styrofoam coffee cup and scalded a customer. The company lost the suit and the word went down to find a way to make sure that the lid stays on and the cup does not leak – a specialized, difficult measurement that required a custom solution.

The hand held gage pictured provides the perfect solution to this application. The cup and lid are both measured with the same gage, with a simple sensor change to go from one to the other.

Each are measured to within $\pm .001$ ".

The result is a reliable and accurate system that keeps the lid on the cup and prevents leaks. The fast food customer is safe from hot coffee and our customer is safe from costly lawsuits.



SPECIAL GAGING

TURBINE COMPRESSOR ROTOR SPACERS

This inspection fixture checks gas turbine engine compressor rotor spacers for radial size and runout at five stages.

It represents a specific Starrett special gage capability — the designing and building of large, ultra-precise fixture gages mounted on Starrett precision granite surface plates which meet or exceed U.S. Federal Specification GGG-P-463C.

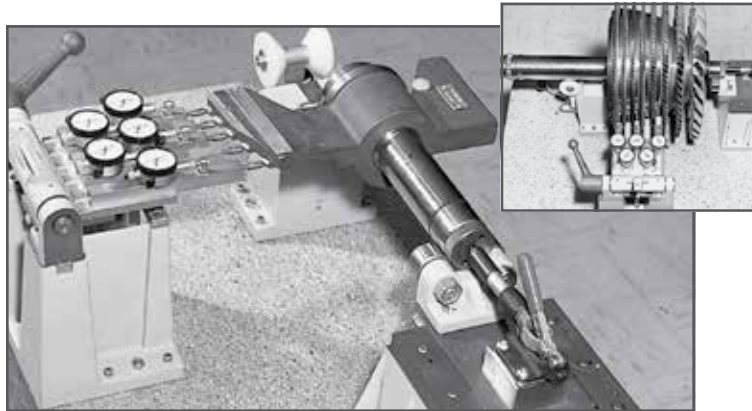

Inset: Rotor turns 360° on its axis to determine runout and radial deviation.

TURBINE NOZZLE DIAPHRAGM OPENING GAGE

This gage checks three critical dimensions in the nozzle. This is an older and less complex design than the gage above, and it does not measure the radial height dimension.



Gage on setting master

Test Master segment

AEROSPACE

AREA FLOW GAGE

Area Flow Gages measure the minimum area openings of turbine engine nozzles. Area readings are in .001 square inch resolution. It uses eight or more contacts that reach into the throat of the turbine nozzle openings. The recorded measurements are transferred via hydraulic cylinders to a dial indicator. Using mechanical linkage and hydraulics the algebraic area is transferred to the indicator or electronic probe at the top of the gage. Openings of segments are matched and located opposite one another on the engine circumference to provide a balanced air flow. These gages are custom designed for each stage of the turbine and are critical to proper engine performance and operation.

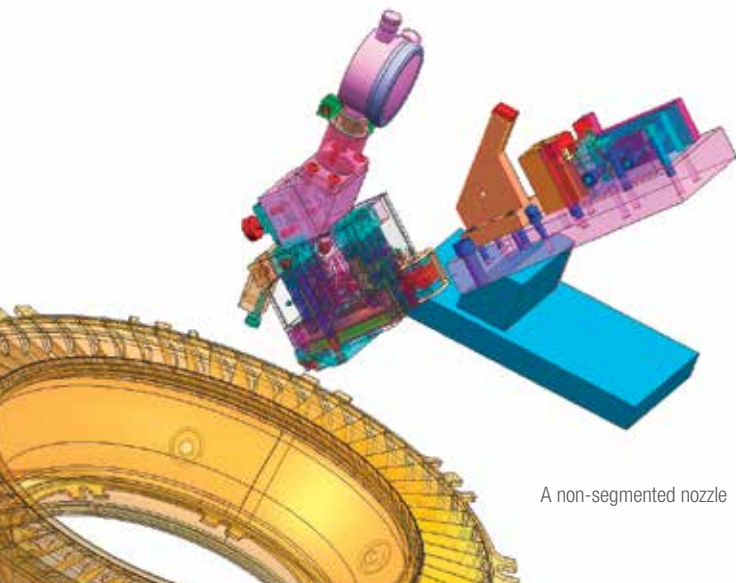

A non-segmented nozzle



SPECIAL GAGING

HIGH PRECISION CYLINDER MEASUREMENT

We offer a full range of snap gages that utilize highly polished carbide contacts to measure cylindrical parts to as close as ± 0.0001 ".

The gage has an insulated handle with a thumb activated contact lift and a bump stop.

Each gage with optional master can measure a 1" range with exceptional accuracy.

They are available as bench or handheld gages.

ADJUSTABLE RANGE SNAP GAGES

These snap gages have a lightweight aluminum frame and low-friction ball bushing motion transfer.

The indicator can be rotated and locked for easy viewing in any position.

Ball contacts or contacts for grooves are also available. They are also available with electronic indicators.

They have simple and rugged construction including sturdy dovetail slides for range adjustment. This is a proven low maintenance gage with a long trouble-free life.

Three standard size ranges are available: 6-10", 10-14", and 14-18".



Measuring a turbine component.



SPECIAL GAGING

OUTSIDE AND INSIDE DIAMETER GAGES

Individually designed and built for each application, these gages have a low-friction bushing direct-transfer mechanism and will repeat within one graduation.

It is made of aluminum for light weight and to preserve the proper "feel". Gage contacts and rest feet are carbide for long wear.

The steel tube master has carbide rests and pads for accuracy and wear control.

Shown here is an angled outside diameter gage in position on the setting master to set the indicator to zero.

This specific gage was designed to measure the diameter on conical parts.



Angled outside Diameter Gage with Setting Master

INSIDE DIAMETER GAGE

Inside diameter gage, moderately deep reach. Design permits inside measuring, while clearing hub obstructions. (Conventional straight bar would be used otherwise).

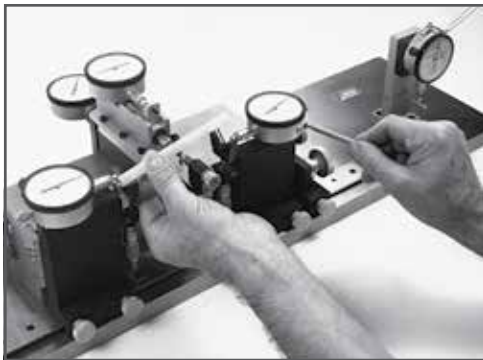
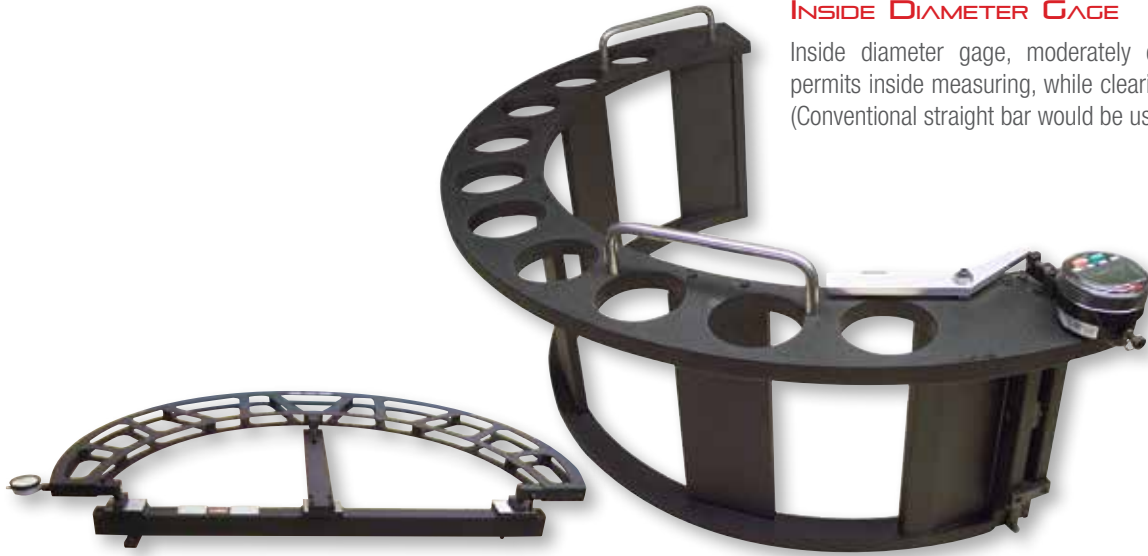

Inserting ceramic cylinder in gage to check squareness and parallelism of ends, longitudinal bow and out-of-roundness

MULTI-READOUT AND SPECIAL PURPOSE GAGES

This complex five-station fixture gage checks critical dimensions and geometry of precision cylinders.

This single fixture checks overall length to ± 0.010 ", squareness and parallelism of the ends to within $.002$ ", longitudinal bow to within $.005$ ", out-of-roundness to within $.003$ " T.I.R, and wall thickness to within ± 0.003 ".

The gage includes micrometer head height adjustment of the work-staging V-rests. It has precision ball slide mounts for dial indicators at two of the stations and wear-resisting carbide contacts at all gaging stations.





ULTRA-LIGHT HONEYCOMB DEEP THROAT AND LARGE DIAMETER GAGES

A large diameter or deep-throated gage no longer has to be heavy and hard to handle. Starrett special gage engineers have studied the physical and structural properties of honeycomb aluminum, establishing standards covering the selection and use of this lightweight material.

The results were long-range measurement to close tolerances in hand-held gages of many configurations, all combining great rigidity with light weight and ease of handling.

It measures diameters to 72" (180cm) and throat depths to 24" (60cm).

ULTRA-LIGHT DEEP THROAT GAGE

This deep throat indicating micrometer gage solves the problem of checking the .281" ($\pm .005$ ") thickness of a fan rotor shaft at a point nearly 15" from its edge.



ULTRA-LIGHT LARGE DIAMETER GAGE

This gage is used as an indicating snap gage by setting the indicator to zero with the set master and then reading the part size variations on the indicator.

The setting master is a Starrett 234 End Measuring Rod with insulated grips and saddle-centering mounts.

Sizes are available from 18" to 24" through 84" to 90".

This gage can be made into an adjustable snap gage by fitting one end with a micrometer and the other end with an indicator. They are available with dial or electronic indicators.

Other concepts are available to suit specific requirements.



SPECIAL GAGING

SPECIAL GEOMETRIES

THICKNESS GAGES

We have fulfilled many requests for special purpose gages to measure material thickness in hard to reach areas.



Thickness gage
with roller contacts

Wall thickness gages

QUICK-ADJUSTING MICROMETER HEAD

We have developed a number of custom gages utilizing a Starrett 30380 Quick Adjusting Micrometer Head. It greatly increases the speed with which measurements can be taken.

Pressing a button on the thimble allows the spindle to slide along its axis to any position within its range. Releasing the button re-engages the spindle threads, and thimble rotation is then used for final size adjustment.

Gages with these micrometer heads can save a lot of time when taking precise measurements in hard to access areas



DIAL PROTRACTOR HEADS

Starrett Dial Protractor Heads for special applications permit rapid angular measurements. With 90° range and graduations of 5' they will assure accurate measurements.

Specifications – Bezel diameter is 2-1/4"; case thickness is 1.34" from crystal to back; .25" dia. input shaft projects .63" from back of case. Main dial reading to customer specification; graduation – specify 0°5', 0°10' or 0°15'. Also available with balanced dials and with counterclockwise figures in red.

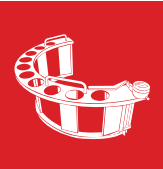

SPECIAL GAGING

UNIVERSAL BENCH GAGE

Sizes from 0 to 4" are rapidly checked to .0001" accuracy with a dial or electronic indicator. The gage range is $\pm .100$ " from the zero set point on a master. A rugged ball bushing motion transfer provides accuracy for many maintenance-free years.

With optional contacts, this gage can be quickly set up to check inside and outside diameters, slot and groove widths, length or thickness, and splines or gear pitch diameters.

Move the lockable slide to reverse this gaging direction. Attach the required contacts and set the indicator to zero with a master. You are ready to gage a different part in less than five minutes.

The gage is also available with a digital indicator that will hold the reading from one sweep over the part to eliminate errors.



Contacts are available for numerous applications. Optional 2- or 3-point contact sets are available with flat or rounded faces, conical points, steel or carbide balls, and pins for over-roll dimensions.

DATA COLLECTION

SPC requires accurate input of product dimensions. Speed and accuracy are the demands met by this special gage and the 776 Gage -Chek™.

One special gage and one 776 displays and stores up to eight dimensions. As shown, the larger diameter, small diameter, concentricity and length are checked in one step. It takes less than ten seconds to take and store all four dimensions.

The actual sizes are entered into the 776 display. Both the variance from nominal size plus actual size can be displayed.



SPECIAL GAGING

INSIDE DIAMETER DOUBLE-TURRET GAGES

This gage was designed to fit through a diameter much smaller than the one to be gaged. A double-turret gage can check an I.D. up to two times larger than the hole it will pass through. Single-turret gages can be designed for I.D.s up to one and one-half times larger than the hole it will pass through. Accurate gages have been supplied that will reach 36" deep.

Gage shown open for mastering or measuring.

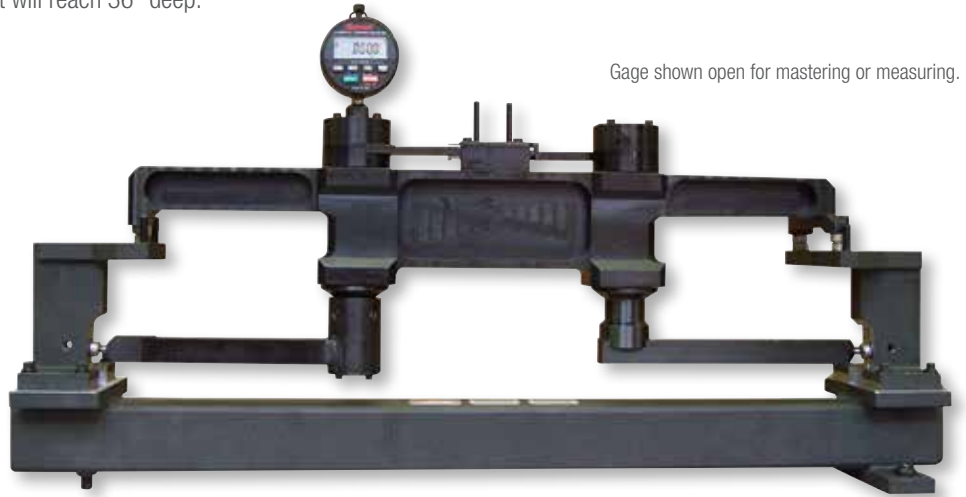

Gage folded for insertion or removal.



Turrent gage shown open for inspecting parts.



SPECIAL GAGING

VARIABLE HEIGHT DIAMETER RADIUS GAGE

Diameters, radii and lengths (from known "bump stops") can be measured using this long gaging range, electronic indicator assembly.

It is capable of locking into position at specific heights and moved up or down as needed.

Gage (right) shown on top of master (below and left)

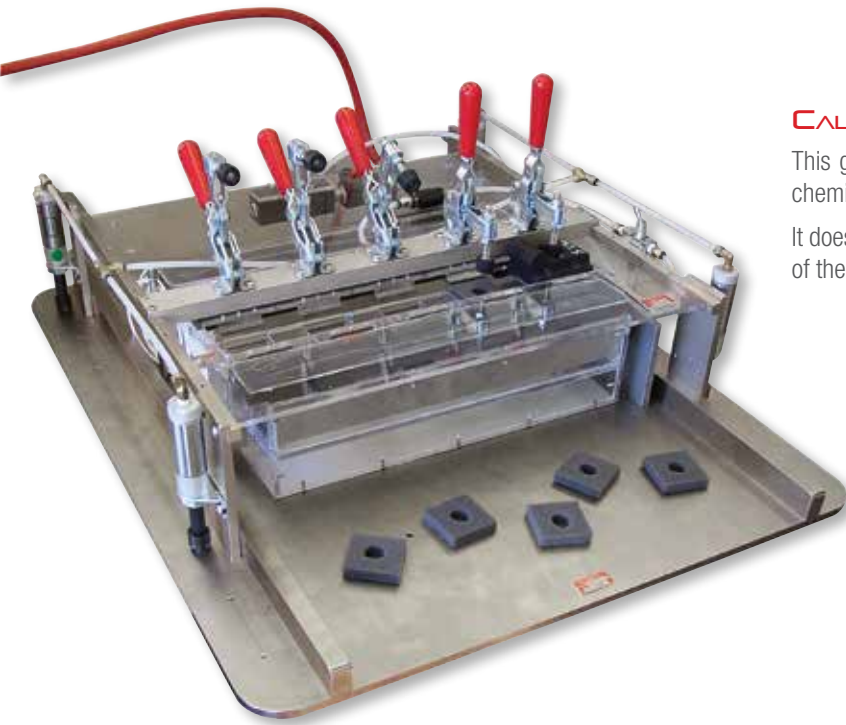

CALIBRATION GAGE WITH PNEUMATIC ADJUSTMENT

This gage is used to check the equipment that detects the level of a chemical in two tanks.

It does not do the actual measuring, but verifies the validity/compliance of the detectors.



PERFORMANCE RACING

STAGGER PRO 1000

The Stagger Pro 1000 utilizes electronic caliper technology to quickly and accurately record front and rear stagger for oval track car setup. The Stagger Pro is simple to use and eliminates potential errors that could result in costly setup mistakes. With simple button presses the Stagger Pro quickly measures each tire and calculates the front and rear stagger. Adjustable to accommodate a variety of tire sizes.



RIDE HEIGHT GAGE

Controlling the ride-height of a car is one of the most strict rules in racing. Starrett developed a custom-engineered Ride Height Gage that provides easier, more precise measurement before and after the race.



CYLINDER BORE GAGE

The design of the cylinder gage is to access the engine's piston cylinder cavity through the spark plug opening. The design allows a quick check of racing specifications of the cylinder cavity diameter, especially modifications beyond what's acceptable, without the need to dismantle the engine block for access.





SQUARES

SQUARES

Starrett squares are offered in a practical variety of styles to suit the needs of the individual, whether it be a toolmaker, mechanic, carpenter, or a "do-it-yourself" homeowner.

The Starrett name has always been associated with squares because our founder, Laroy Starrett, invented the combination square in 1877. The success of this tool led to the beginning of The L.S. Starrett Company in 1880. The combination square is one of the world's most practical and versatile tool inventions – the basic tool for every builder and craftsman.

SQUARES

In this section you will see combination squares, solid test or try squares, and special squares for tool and diemakers and carpenters.

To check squareness at the highest level of accuracy, we recommend our TS True Squares. These are available in three styles down to the amazing accuracy of 1/4 second. These are listed in the Gage Block Section of this catalog.

We also offer granite squares which are listed in the Granite Surface Plate Section of this catalog. The main purpose of these squares is for checking the X, Y, and Z axes on CNC machine tools and coordinate measuring machines.



COMBINATION SQUARES FEATURE:

- A choice of smooth-finished forged and hardened (longer wearing) steel square head and center head, or a cast iron square head and center head. All bearing surfaces are accurately ground.
- A choice of stable cast iron protractors – reversible or non-reversible style – all nicely finished with a black, durable finish
- Protractors are furnished as reversible, with shoulders on both sides of the blade, or non-reversible, with a single shoulder on one side of the blade only. All protractors also have a spirit level.
- Protractor heads have revolving turrets with direct-reading double graduations, 0-180° in opposite directions. This permits the direct reading of angles and supplementary angles.
- Most square heads have a handy spirit level and a hardened scriber
- Square blades and protractor heads come in a choice of regular or Starrett no-glare satin chrome finish
- A reversible lock bolt allows the blade to be turned over or end-for-end without removing the lock bolt or nut. This ensures true alignment of the blade and heads.
- Square blades feature easy-to-read, sharp graduations and are available in many convenient styles
- Separate parts and attachments available

TIPS FOR USING SQUARES AND CENTER HEADS

First, make sure your square is clean and that it is located against a flat surface – burrs on metal or knots and bumps on wood will throw squareness off.

Second, to scribe a line, the steel scriber can be used on any material, but usually on metal. A carpenter's pencil is normally used on wood, but if finer lines are needed, a light cut with a utility knife may be used. This is also handy when scribing cross grain.

Third, when using a center head on a piece that may not be completely round, it is good practice to scribe more than two intersecting lines.



COMBINATION SQUARES

Starrett combination squares consist of a photo-engraved, hardened and tempered steel rule (or blade) on which is mounted on an adjustable square head.

Starrett Combination Square Heads are made of cast iron or forged and hardened steel and are not to be confused with the cheap imitation plastic or die cast heads on the market. The value of Starrett tools is that they are accurate and will last.

As the name indicates, these tools can be used for many different purposes – a complete substitute for a whole set of common solid try squares, a 45 degree miter, a depth gage, a height gage, a marking or scribing gage, a level, a plumb and, by withdrawing the blade, it can also be used as a precision rule. This saves littering the workbench with too many tools, each being necessary but may be used less. This results in the goal of all good craftsmen – better accuracy and greater efficiency.

The combination square with center head is a basic combination set. The center head is a convenient and accurate way to find the center of round work.

Complete combination sets feature the combination square with a center head and with either a reversible or non-reversible protractor. Details of the protractors are also included in the Protractor and Angle Measurements Section of this catalog.



Combination square



Combination square with head



Combination set



COMBINATION SQUARES

11H CAST IRON HEADS

With reversible lock bolt, scribe, spirit level (except 4"), and hardened steel, photo-engraved blade with regular or satin chrome finish. Cast iron head with black wrinkle finish.



C11H-12-4R

33H FORGED AND HARDENED STEEL HEADS

These squares have the same features as the 11 cast iron heads except that the square heads are forged hardened steel with smooth, black enamel finish.



C33H-12-4R

4-24" Combination Squares with Square Head

| 11H Cast Iron Heads with Black Wrinkle Finish | | 33H Forged and Hardened Steel Heads with Smooth Black Enamel Finish | | Size | Graduation | Blade |
|--|-------|---|-------|--------------|---|--------------|
| Cat. No. | EDP | Cat. No. | EDP | | | |
| 11H-4-4R | 50049 | 33H-4-4R | 50203 | 4" | 4R – 8ths, 16ths, Quick Reading 32nds, 64ths | Regular |
| C11H-4-4R | 56360 | C33H-4-4R | 56390 | | | Satin Chrome |
| 11H-6-4R | 50051 | 33H-6-4R | 50205 | 6" | 4R – 8ths, 16ths, Quick Reading 32nds, 64ths | Regular |
| C11H-6-4R | 56362 | C33H-6-4R | 56392 | | | Satin Chrome |
| 11H-6-16R | 50053 | 33H-6-16R | 50207 | 6" | 16R – Quick Reading 32nds, 64ths, Aircraft Quick Reading 50ths, 100ths | Regular |
| C11H-6-16R | 56364 | C33H-6-16R | 56394 | | | Satin Chrome |
| 11H-12-4R | 50055 | 33H-12-4R | 50209 | 12" | 4R – 8ths, 16ths, Quick Reading 32nds, 64ths | Regular |
| C11H-12-4R | 56366 | C33H-12-4R | 56396 | | | Satin Chrome |
| C11H-12-4RW/SLC* | 66896 | C33H-12-4RW/SLC* | 66897 | 12" | 4R – 8ths, 16ths, Quick Reading 32nds, 64ths | Satin Chrome |
| 11H-12-16R | 50057 | 33H-12-16R | 50211 | | | 12" |
| C11H-12-16R | 56368 | C33H-12-16R | 56398 | Satin Chrome | | |
| 11H-18-4R | 50059 | 33H-18-4R | 50213 | 18" | 4R – 8ths, 16ths, Quick Reading 32nds, 64ths | Regular |
| C11H-18-4R | 56370 | C33H-18-4R | 56400 | | | Satin Chrome |
| 11H-18-16R | 50061 | 33H-18-16R | 50215 | 18" | 16R – Quick Reading 32nds, 64ths, Aircraft Quick Reading 50ths, 100ths | Regular |
| C11H-18-16R | 56372 | C33H-18-16R | 56402 | | | Satin Chrome |
| 11H-24-4R | 50063 | 33H-24-4R | 50217 | 24" | 4R – 8ths, 16ths, Quick Reading 32nds, 64ths | Regular |
| C11H-24-4R | 56374 | C33H-24-4R | 56404 | | | Satin Chrome |
| 11H-24-16R | 50065 | 33H-24-16R | 50219 | 24" | 16R – Quick Reading 32nds, 64ths, Aircraft Quick Reading 50ths, 100ths | Regular |
| C11H-24-16R | 56376 | C33H-24-16R | 56406 | | | Satin Chrome |

150-600mm Combination Squares with Square Head

| 11MH Cast Iron Heads with Black Wrinkle Finish | | 33MH Forged and Hardened Steel Heads with Smooth Black Enamel Finish | | Size | Graduation | Blade |
|---|-------|--|-------|-------|-------------------------|--------------|
| Cat. No. | EDP | Cat. No. | EDP | | | |
| 11MH-150 | 56241 | 33MH-150 | 56247 | 150mm | mm and 1/2mm Both Sides | Regular |
| C11MH-150 | 56380 | C33MH-150 | 56410 | | | Satin Chrome |
| 11MH-300 | 56243 | 33MH-300 | 56249 | 300mm | mm and 1/2mm Both Sides | Regular |
| C11MH-300 | 56382 | C33MH-300 | 56412 | | | Satin Chrome |
| 11MH-600 | 56245 | 33MH-600 | 56251 | 600mm | mm and 1/2mm Both Sides | Regular |
| C11MH-600 | 56384 | C33MH-600 | 56414 | | | Satin Chrome |

300-600mm and 11-3/4 – 23-1/2" Combination Squares with Square Head

| 11MEH Cast Iron Heads with Black Wrinkle Finish | | 33MEH Forged and Hardened Steel Heads with Smooth Black Enamel Finish | | Size | Graduation | Blade |
|--|-------|---|-------|----------------------|--|--------------|
| Cat. No. | EDP | Cat. No. | EDP | | | |
| 11MEH-300 | 50067 | 33MEH-300 | 50221 | 300mm and 11-3/4" | 1/2mm and 32nds One Side; mm and 64ths Reverse Side | Regular |
| C11MEH-300 | 56386 | C33MEH-300 | 56416 | | | Satin Chrome |
| 11MEH-600 | 56121 | 33MEH-600 | 50237 | 600mm and 23-1/2" | 1/2mm and 32nds One Side; mm and 64ths Reverse Side | Regular |
| C11MEH-600 | 56388 | C33MEH-600 | 56418 | | | Satin Chrome |

* Includes redemption card for Standard Letter of Certification (SLC).



COMBINATION SQUARES

COMBINATION SQUARES WITH CENTER HEADS

11HC CAST IRON HEADS

With reversible lock bolts, scribe, spirit level (except 4"), and hardened steel, photo-engraved blade with regular or satin chrome finish. Cast iron heads with black wrinkle finish.

33HC FORGED AND HARDENED STEEL HEADS

These squares have the same features as the 11HC cast iron heads except that the square heads and center heads are forged hardened steel with smooth, black enamel finish.

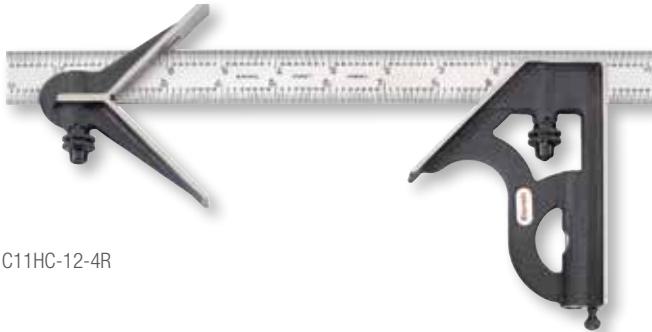

C11HC-12-4R



C33HC-12-4R

4-24" Combination Squares with Square and Center Heads

| 11HC Cast Iron Heads with Black Wrinkle Finish | | 33HC Forged and Hardened Steel Heads with Smooth Black Enamel Finish | | Size | Graduation | Blade |
|---|-------|--|-------|------|---|-------------------------|
| Cat. No. | EDP | Cat. No. | EDP | | | |
| 11HC-4-4R | 50050 | 33HC-4-4R | 50204 | 4" | 4R – 8ths, 16ths, Quick Reading 32nds, 64ths | Regular Satin Chrome |
| C11HC-4-4R | 56361 | C33HC-4-4R | 56391 | | | |
| 11HC-6-4R | 50052 | 33HC-6-4R | 50206 | 6" | 4R – 8ths, 16ths, Quick Reading 32nds, 64ths | Regular Satin Chrome |
| C11HC-6-4R | 56363 | C33HC-6-4R | 56393 | | | |
| 11HC-6-16R | 50054 | 33HC-6-16R | 50208 | 6" | 16R – Quick Reading 32nds, 64ths, Aircraft Quick Reading 50ths, 100ths | Regular Satin Chrome |
| C11HC-6-16R | 56365 | C33HC-6-16R | 56395 | | | |
| 11HC-12-4R | 50056 | 33HC-12-4R | 50210 | 12" | 4R – 8ths, 16ths, Quick Reading 32nds, 64ths | Regular Satin Chrome |
| C11HC-12-4R | 56367 | C33HC-12-4R | 56397 | | | |
| 11HC-12-16R | 50058 | 33HC-12-16R | 50212 | 12" | 16R – Quick Reading 32nds, 64ths, Aircraft Quick Reading 50ths, 100ths | Regular Satin Chrome |
| C11HC-12-16R | 56369 | C33HC-12-16R | 56399 | | | |
| 11HC-18-4R | 50060 | 33HC-18-4R | 50214 | 18" | 4R – 8ths, 16ths, Quick Reading 32nds, 64ths | Regular Satin Chrome |
| C11HC-18-4R | 56371 | C33HC-18-4R | 56401 | | | |
| 11HC-18-16R | 50062 | 33HC-18-16R | 50216 | 18" | 16R – Quick Reading 32nds, 64ths, Aircraft Quick Reading 50ths, 100ths | Regular Satin Chrome |
| C11HC-18-16R | 56373 | C33HC-18-16R | 56403 | | | |
| 11HC-24-4R | 50064 | 33HC-24-4R | 50218 | 24" | 4R – 8ths, 16ths, Quick Reading 32nds, 64ths | Regular Satin Chrome |
| C11HC-24-4R | 56375 | C33HC-24-4R | 56405 | | | |
| 11HC-24-16R | 50066 | 33HC-24-16R | 50220 | 24" | 16R – Quick Reading 32nds, 64ths, Aircraft Quick Reading 50ths, 100ths | Regular Satin Chrome |
| C11HC-24-16R | 56377 | C33HC-24-16R | 56407 | | | |

150-600mm Combination Squares with Square and Center Heads

| 11MHC Cast Iron Heads with Black Wrinkle Finish | | 33MHC Forged and Hardened Steel Heads with Smooth Black Enamel Finish | | Size | Graduation | Blade |
|--|-------|---|-------|-------|-------------------------|-------------------------|
| Cat. No. | EDP | Cat. No. | EDP | | | |
| 11MHC-150 | 56242 | 33MHC-150 | 56248 | 150mm | mm and 1/2mm Both Sides | Regular Satin Chrome |
| C11MHC-150 | 56381 | C33MHC-150 | 56411 | | | |
| 11MHC-300 | 56244 | 33MHC-300 | 56250 | 300mm | mm and 1/2mm Both Sides | Regular Satin Chrome |
| C11MHC-300 | 56383 | C33MHC-300 | 56413 | | | |
| 11MHC-600 | 56246 | 33MHC-600 | 56252 | 600mm | mm and 1/2mm Both Sides | Regular Satin Chrome |
| C11MHC-600 | 56385 | C33MHC-600 | 56415 | | | |

300-600mm and 11-3/4 – 23-1/2" Combination Squares with Square and Center Heads

| 11MEHC Cast Iron Heads with Black Wrinkle Finish | | 33MEHC Forged and Hardened Steel Heads with Smooth Black Enamel Finish | | Size | Graduation | Blade |
|---|-------|--|-------|----------------------|--|-------------------------|
| Cat. No. | EDP | Cat. No. | EDP | | | |
| 11MEHC-300 | 50068 | 33MEHC-300 | 50222 | 300mm and 11-3/4" | 1/2mm and 32nds One Side; mm and 64ths Reverse Side | Regular Satin Chrome |
| C11MEHC-300 | 56387 | C33MEHC-300 | 56417 | | | |
| 11MEHC-600 | 50075 | 33MEHC-600 | 50238 | 600mm and 23-1/2" | 1/2mm and 32nds One Side; mm and 64ths Reverse Side | Regular Satin Chrome |
| C11MEHC-600 | 56389 | C33MEHC-600 | 56419 | | | |



COMBINATION SETS

COMBINATION SQUARE WITH CENTER AND REVERSIBLE PROTRACTOR HEADS

435 SQUARE, CENTER AND PROTRACTOR HEAD

CAST IRON

With reversible lock bolts, scribe, spirit level in both square head and protractor head, direct reading double 180° protractor scale, hardened steel, photo-engraved blade. Cast iron heads with black wrinkle finish. Also available with satin chrome blade and protractor head.



C435-12-4R



C434-12-4R



Supplied in protective case

434 FORGED AND HARDENED STEEL SQUARE AND CENTER HEADS, CAST IRON PROTRACTOR HEAD

THE VERY BEST SETS AVAILABLE

These squares have the same features as the 435 except that the square heads and center heads are forged, hardened steel with smooth, black enamel finish.

12-24" Combination Sets with Square, Center and Reversible Protractor Head and Blade

| 435 Sets Cast Iron Heads with Black Wrinkle Finish | | 434 Sets Forged and Hardened Square and Center Heads, Cast Iron Protractor Head with Smooth Black Finish | | Size | Graduation | Blade |
|---|-------|---|-------|------|--|--------------|
| Cat. No. | EDP | Cat. No. | EDP | | | |
| 435-12-4R | 51556 | 434-12-4R | 51542 | 12" | 4R – 8ths, 16ths, Quick Reading 32nds, 64ths | Regular |
| C435-12-4R | 66682 | C434-12-4R | 51548 | | | Satin Chrome |
| | | C434-12-4R W/SLC* | 66898 | | | |
| 435-12-16R | 51557 | 434-12-16R | 51543 | 12" | 16R – Quick Reading 32nds, 64ths, Aircraft Quick Reading 50ths, 100ths | Regular |
| | | C434-12-16R | 51549 | | | Satin Chrome |
| 435-18-4R** | 51558 | 434-18-4R** | 51544 | 18" | 4R – 8ths, 16ths, Quick Reading 32nds, 64ths | Regular |
| | | C434-18-4R** | 51550 | | | Satin Chrome |
| | | 434-18-16R** | 51545 | 18" | 16R – Quick Reading 32nds, 64ths, Aircraft Quick Reading 50ths, 100ths | Regular |
| | | C434-18-16R** | 51551 | | | Satin Chrome |
| 435-24-4R** | 51559 | 434-24-4R** | 51546 | 24" | 4R – 8ths, 16ths, Quick Reading 32nds, 64ths | Regular |
| | | C434-24-4R** | 51552 | | | Satin Chrome |
| | | 434-24-16R** | 51547 | 24" | 16R – Quick Reading 32nds, 64ths, Aircraft Quick Reading 50ths, 100ths | Regular |
| | | C434-24-16R** | 51553 | | | Satin Chrome |

300-600mm Combination Sets with Square, Center and Reversible Protractor Head and Blade

| 435M Sets Cast Iron Heads with Black Wrinkle Finish | | 434M Sets Forged and Hardened Square and Center Heads, Cast Iron Protractor Head with Smooth Black Finish | | Size | Graduation | Blade |
|--|-------|--|-------|-------|-------------------------|--------------|
| Cat. No. | EDP | Cat. No. | EDP | | | |
| 435M-300 | 66177 | 434M-300 | 56255 | 300mm | mm and 1/2mm Both Sides | Regular |
| C435M-300 | 61918 | C434M-300 | 56420 | | | Satin Chrome |
| 435M-600** | 66681 | 434M-600** | 56256 | 600mm | mm and 1/2mm Both Sides | Regular |
| | | C434M-600** | 56421 | | | Satin Chrome |

300-600mm and 11-3/4 – 23-1/2" Combination Sets with Square, Center and Reversible Protractor Head and Blade

| 435ME Sets Cast Iron Heads with Black Wrinkle Finish | | 434ME Sets Forged and Hardened Square and Center Heads, Cast Iron Protractor Head with Smooth Black Finish | | Size | Graduation | Blade |
|---|-------|---|-------|-------------------|---|--------------|
| Cat. No. | EDP | Cat. No. | EDP | | | |
| 435ME-300 | 51560 | 434ME-300 | 51554 | 300mm and 11-3/4" | 1/2mm and 32nds One Side; mm and 64ths Reverse Side | Regular |
| | | C434ME-300 | 56422 | | | Satin Chrome |
| 435ME-600** | 51561 | 434ME-600** | 51555 | 600mm and 23-1/2" | 1/2mm and 32nds One Side; mm and 64ths Reverse Side | Regular |
| | | C434ME-600** | 56423 | | | Satin Chrome |

* Includes redemption card for Standard Letter of Certification (SLC).

** Does not include case.



COMBINATION SETS

COMBINATION SQUARE WITH CENTER AND NON-REVERSIBLE PROTRACTOR HEAD

9 COMBINATION SETS WITH SQUARE, CENTER AND NON-REVERSIBLE PROTRACTOR HEAD

CAST IRON

With reversible lock bolts, scribe, spirit level in both square head and protractor head, direct reading double 180° protractor scale, and hardened steel, photo-engraved blade. Cast iron heads with black wrinkle finish. Also available with satin chrome blade and protractor head.



SQUARES



9-12-4R

Supplied in protective case

| 12-24" Combination Sets with Square, Center and Non-reversible Protractor Head and Blade | | | | |
|--|-------|-------------------|---|--------------|
| Cast Iron Heads with Black Wrinkle Finish | | | | |
| Cat. No. | EDP | Size | Graduation | Blade |
| 9-12-4R | 50042 | 12" | 4R – 8ths, 16ths, Quick Reading 32nds, 64ths | Regular |
| C9-12-4R | 50046 | 12" | 4R – 8ths, 16ths, Quick Reading 32nds, 64ths | Satin Chrome |
| 9-12-16R | 50043 | 12" | 16R – Quick Reading 32nds, 64ths, Air Craft Quick Reading 50ths, 100ths | Regular |
| 9-18-4R | 50044 | 18" | 4R – 8ths, 16ths, Quick Reading 32nds, 64ths | Regular |
| 9-24-4R | 50045 | 24" | 4R – 8ths, 16ths, Quick Reading 32nds, 64ths | Regular |
| 300-600mm Combination Sets with Square, Center and Non-reversible Protractor Head and Blade | | | | |
| Cast Iron Heads with Black Wrinkle Finish | | | | |
| Cat. No. | EDP | Size | Graduation | Blade |
| 9M-300 | 56253 | 300mm | mm and 1/2mm Both Sides | Regular |
| 9M-600 | 56254 | 600mm | mm and 1/2mm Both Sides | Regular |
| 300-600mm and 11-3/4 – 23-1/2" Combination Sets with Square, Center and Non-Reversible Protractor Head and Blade | | | | |
| Cast Iron Heads with Black Wrinkle Finish | | | | |
| Cat. No. | EDP | Size | Graduation | Blade |
| 9ME-300 | 50047 | 300mm and 11-3/4" | 1/2mm and 32nds One Side; mm and 64ths Reverse Side | Regular |
| 9ME-600 | 50048 | 600mm and 23-1/2" | 1/2mm and 32nds One Side; mm and 64ths Reverse Side | Regular |



COMBINATION SETS

BLADES FOR COMBINATION SQUARES, SETS AND BEVEL PROTRACTORS

INCH, MILLIMETER AND INCH/MILLIMETER

The blades listed below fit any head according to the sizes noted in the charts on all combination squares, combination sets and bevel protractors. The 12", 18", 24", 36" and 48" and 300mm and 600mm sizes are interchangeable. Exception: Starrett 33J and 8 Combination Squares. (For these, see 33J and 8 listings.)

| Inch Blades Only for Combination Squares, Sets and Bevel Protractors | | | | | |
|---|-------|-------------------|---------------------------|--|--------------|
| Cat. No. | EDP | Size | Approx. Width x Thickness | Graduation | Finish |
| B4-4R | 50076 | 4" | 5/8 x 1/16" | 4R – 8ths, 16ths, Quick Reading 32nds, 64ths | Regular |
| CB4-4R | 50077 | 4" | 5/8 x 1/16" | 4R – 8ths, 16ths, Quick Reading 32nds, 64ths | Satin Chrome |
| CB4-16R | 50078 | 4" | 5/8 x 1/16" | 16R – Quick Reading 32nds, 64ths, Aircraft Quick Reading 50ths, 100ths | Satin Chrome |
| B6-4R | 50079 | 6" | 3/4 x 5/64" | 4R – 8ths, 16ths, Quick Reading 32nds, 64ths | Regular |
| CB6-4R | 50080 | 6" | 3/4 x 5/64" | 4R – 8ths, 16ths, Quick Reading 32nds, 64ths | Satin Chrome |
| B6-16R | 50081 | 6" | 3/4 x 5/64" | 16R – Quick Reading 32nds, 64ths, Aircraft Quick Reading 50ths, 100ths | Regular |
| CB6-16R | 50082 | 6" | 3/4 x 5/64" | 16R – Quick Reading 32nds, 64ths, Aircraft Quick Reading 50ths, 100ths | Satin Chrome |
| B12-4R | 50083 | 12" | 1 x 3/32" | 4R – 8ths, 16ths, Quick Reading 32nds, 64ths | Regular |
| CB12-4R | 50084 | 12" | 1 x 3/32" | 4R – 8ths, 16ths, Quick Reading 32nds, 64ths | Satin Chrome |
| CB12-6R | 50085 | 12" | 1 x 3/32" | 6R – Aircraft Quick Reading 50ths and 10ths | Satin Chrome |
| B12-16R | 50086 | 12" | 1 x 3/32" | 16R – Quick Reading 32nds, 64ths, Aircraft Quick Reading 50ths, 100ths | Regular |
| CB12-16R | 50087 | 12" | 1 x 3/32" | 16R – Quick Reading 32nds, 64ths, Aircraft Quick Reading 50ths, 100ths | Satin Chrome |
| B18-4R | 50088 | 18" | 1 x 3/32" | 4R – 8ths, 16ths, Quick Reading 32nds, 64ths | Regular |
| CB18-4R | 50089 | 18" | 1 x 3/32" | 4R – 8ths, 16ths, Quick Reading 32nds, 64ths | Satin Chrome |
| B18-16R | 50090 | 18" | 1 x 3/32" | 16R – Quick Reading 32nds, 64ths, Aircraft Quick Reading 50ths, 100ths | Regular |
| CB18-16R | 50091 | 18" | 1 x 3/32" | 16R – Quick Reading 32nds, 64ths, Aircraft Quick Reading 50ths, 100ths | Satin Chrome |
| B24-4R | 50092 | 24" | 1 x 3/32" | 4R – 8ths, 16ths, Quick Reading 32nds, 64ths | Regular |
| CB24-4R | 50093 | 24" | 1 x 3/32" | 4R – 8ths, 16ths, Quick Reading 32nds, 64ths | Satin Chrome |
| CB24-6R | 50094 | 24" | 1 x 3/32" | 6R – Aircraft Quick Reading 50ths and 10ths | Satin Chrome |
| B24-16R | 50095 | 24" | 1 x 3/32" | 16R – Quick Reading 32nds, 64ths, Aircraft Quick Reading 50ths, 100ths | Regular |
| CB24-16R | 50096 | 24" | 1 x 3/32" | 16R – Quick Reading 32nds, 64ths, Aircraft Quick Reading 50ths, 100ths | Satin Chrome |
| CB36-4R | 50097 | 36" | 1 x 3/32" | 4R – 8ths, 16ths, Quick Reading 32nds, 64ths | Satin Chrome |
| CB36-16R | 50098 | 36" | 1 x 3/32" | 16R – Quick Reading 32nds, 64ths, Aircraft Quick Reading 50ths, 100ths | Satin Chrome |
| CB48-4R | 67102 | 48" | 1 x 3/32" | 4R – 8ths, 16ths, Quick Reading 32nds, 64ths | Satin Chrome |
| Millimeter Blades Only for Combination Squares, Sets and Bevel Protractors | | | | | |
| Cat. No. | EDP | Size | Approx. Width x Thickness | Graduation | Finish |
| B150-35 | 55985 | 150mm | 19 x 2mm | 35 – mm and 1/2mm Both Sides | Regular |
| CB150-35 | 55988 | 150mm | 19 x 2mm | 35 – mm and 1/2mm Both Sides | Satin Chrome |
| B300-35 | 55986 | 300mm | 25 x 2.4mm | 35 – mm and 1/2mm Both Sides | Regular |
| CB300-35 | 55989 | 300mm | 25 x 2.4mm | 35 – mm and 1/2mm Both Sides | Satin Chrome |
| B600-35 | 55987 | 600mm | 25 x 2.4mm | 35 – mm and 1/2mm Both Sides | Regular |
| CB600-35 | 55990 | 600mm | 25 x 2.4mm | 35 – mm and 1/2mm Both Sides | Satin Chrome |
| Inch and Millimeter Blades Only for Combination Squares, Sets and Bevel Protractors | | | | | |
| Cat. No. | EDP | Size | Approx. Width x Thickness | Graduation | Finish |
| B150-36 | 55991 | 150mm and 5-3/4" | 19 x 2mm | 36 – 1/2mm and 32nds One Side; mm and 64ths Reverse Side | Regular |
| CB150-36 | 55992 | 150mm and 5-3/4" | 19 x 2mm | 36 – 1/2mm and 32nds One Side; mm and 64ths Reverse Side | Satin Chrome |
| B300-36 | 50101 | 300mm and 11-3/4" | 25 x 2.4mm | 36 – 1/2mm and 32nds One Side; mm and 64ths Reverse Side | Regular |
| CB300-36 | 55993 | 300mm and 11-3/4" | 25 x 2.4mm | 36 – 1/2mm and 32nds One Side; mm and 64ths Reverse Side | Satin Chrome |
| B600-36 | 50102 | 600mm and 23-1/2" | 25 x 2.4mm | 36 – 1/2mm and 32nds One Side; mm and 64ths Reverse Side | Regular |
| CB600-36 | 55994 | 600mm and 23-1/2" | 25 x 2.4mm | 36 – 1/2mm and 32nds One Side; mm and 64ths Reverse Side | Satin Chrome |

All sizes packed one per envelope.

CB12-4R

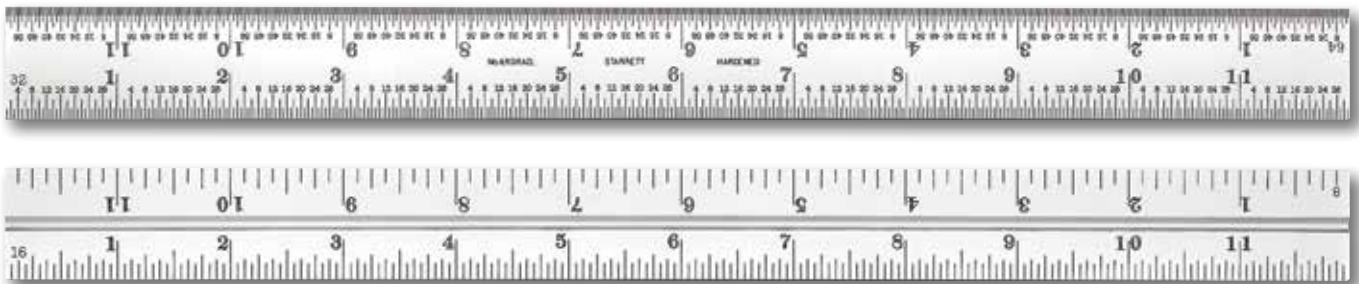

COMBINATION SQUARE BLADES

SQUARE HEADS, CENTER HEADS AND PROTRACTOR HEADS FOR COMBINATION SQUARES, COMBINATION SETS AND BEVEL PROTRACTORS

The heads listed fit any blade according to the sizes noted in the charts on all combination squares, combination sets and bevel protractors. Sizes 12", 18", 24", 36", and 48" and 300mm and 600mm are interchangeable. When ordering, specify complete catalog number and length of blade. Exception: Starrett 33J and 8 Combination Squares. (For these, see 33J and 8 listings.)

| Square Heads Only for Combination Squares, Combination Sets and Bevel Protractors | | | | |
|---|-------|---|-------|-----------------------------------|
| Cast Iron Black Wrinkle Finish | | Forged and Hardened Steel with Smooth Black Enamel Finish | | Fits Blade Size |
| Cat. No. | EDP | Cat. No. | EDP | |
| H11-4 | 50069 | H33-4 | 50223 | 4" |
| H11-6 | 50070 | H33-6 | 50224 | 6" |
| H11-1224 | 50071 | H33-1224 | 50225 | 12" (300mm) 18" 24" (600mm) |
| Center Heads Only for Combination Squares, Combination Sets and Bevel Protractors | | | | |
| Cast Iron Black Wrinkle Finish | | Forged and Hardened Steel with Smooth Black Enamel Finish | | Fits Blade Size |
| Cat. No. | EDP | Cat. No. | EDP | |
| C11-4 | 50072 | C33-4 | 50226 | 4" |
| C11-6 | 50073 | C33-6 | 50227 | 6" |
| C11-1224 | 50074 | C33-1224 | 50228 | 12" (300mm) 18" 24" (600mm) |
| Protractor Heads – Cast Iron (Fits blades 12" and up) for Combination Squares, Combination Sets and Bevel Protractors | | | | |
| Reversible | | Nonreversible | | Finish |
| Cat. No. | EDP | Cat. No. | EDP | |
| PR-1224W | 52525 | PNR-1224W | 50107 | Black Wrinkle |
| CPR-1224W | 64601 | CPNR-1224W | 50108 | Black Wrinkle, Chrome on Turret |
| PR-1224S | 52515 | | | Black Smooth |
| CPR-1224S | 52516 | | | Black Smooth, Chrome on Turret |

For prices of lock bolts, contact the Parts Department.
 4" Center Head Max. Inspection Dia.: 3.125"
 6" Center Head Max. Inspection Dia.: 4.3"
 12"-24" Center Head Max. Inspection Dia.: 5.3"



H11-1224



C33-1224



PR-1224S

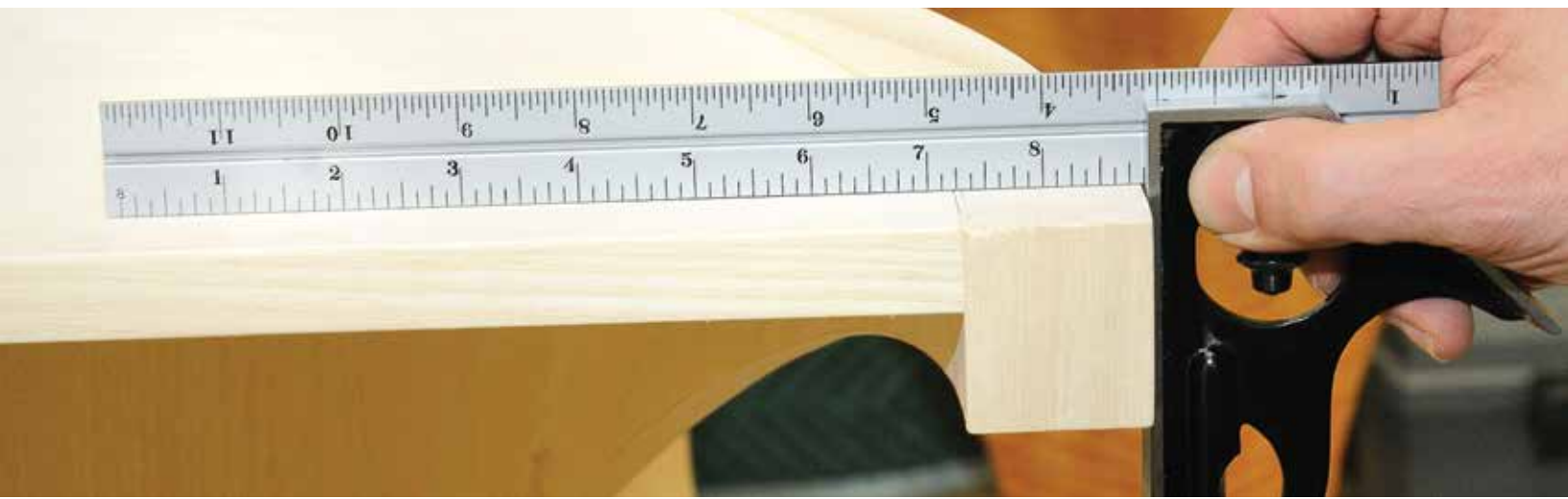

COMBINATION SQUARES

289 ATTACHMENTS FOR COMBINATION SQUARES

These attachments fit combination square blades 1" (25mm) wide and permit attaching rules, blades or thin steel try squares, up to 1" (25mm) wide, at right angles to the blade of the square for laying out key seats, centers, scribing horizontal lines, and measuring diameters. Available in two sizes listed below. Both sizes can also be used with 289C Height and Depth Gage Attachment.

| 289 Attachments for Combination Squares | | | | |
|---|-------|------------------|-------------------|-----------------|
| Cat. No. | EDP | Range Blade/Rule | Seat Length Blade | Rule |
| 289A | 51322 | 1" (25mm) | 1-9/16" (40mm) | 1-11/16" (43mm) |
| 289B | 51323 | | 2-3/8" (60mm) | 2-3/8" (60mm) |

289C HEIGHT AND DEPTH GAGE SET FOR COMBINATION SQUARES

When combined with the 289A or 289B Attachments, this set converts any combination square or set having blades up to 1" (25mm) wide into a height gage or depth gage. In addition to a clamp block, the set has a scribe, 6" rule (610N-6) and a 6" (150mm) rod, any one of which may be inserted in the clamp and locked in position. By applying the scribe, a practical height gage results. Use of the rule converts the tool to a depth gage for measuring in 64ths of an inch. With the rod used as a depth gage, small recesses and holes can also be checked.

| 289C Height and Depth Gage Set for Combination Squares | | |
|--|-------|---------------------------------------|
| Cat. No. | EDP | Description |
| 289C | 51324 | Clamp Block with Scribe, Rule and Rod |

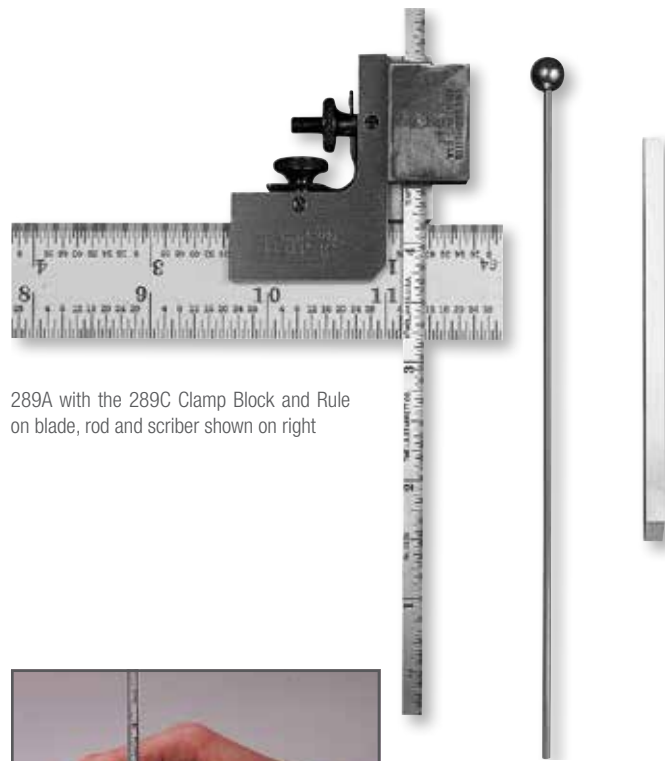
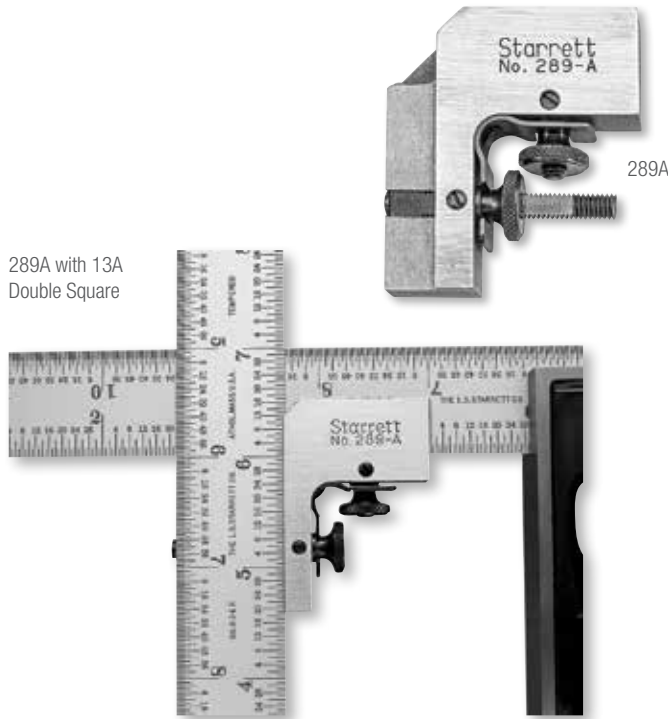

COMBINATION SQUARES

8 LARGE COMBINATION SQUARES

24"

Extra large, heavy-duty construction throughout. The square head is 8-3/8" long and the center head has 4-1/4" arms. Furnished with 24" blade, 1-1/2" wide x 1/10" thick, with distinctive, photo-engraved graduations. Heads are cast iron and have black wrinkle finish.

- Reversible lock bolts
- Accurate spirit level
- Hardened steel blade

8 Large Combination Squares

| Cat. No. | EDP | Graduation | Description |
|----------|-------|------------------------------|----------------------------------|
| 8H | 50037 | 4 – 8ths, 6ths, 32nds, 64ths | With Square Head Only |
| 8HC | 50038 | | With Square Head and Center Head |

Blade Only for 8 Large Combination Squares

| Cat. No. | EDP | Graduation | Description |
|----------|-------|-------------------------------|-------------|
| B824-4 | 50041 | 4 – 8ths, 16ths, 32nds, 64ths | 24" Blade |

Heads Only for 8 Large Combination Squares

| Cat. No. | EDP | Description |
|----------|-------|--------------|
| H8 | 50039 | Square Head |
| C8 | 50040 | Center Head* |

* Max. Inspect Diameter: 7.5"

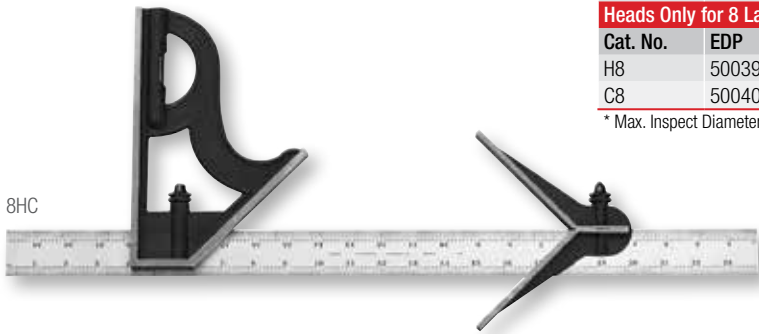

10 STUDENT COMBINATION SQUARES

These tools were designed to train and develop apprentices to lay out and check their work more efficiently. The combination square is far superior to clumsy, old-style solid workshop-grade squares that are still being used in some vocational schools and apprenticeship programs around the world. The student's advantages are:

- Rugged, cast iron square head will outlast cheap plastic and die-cast imitations
- Accurate, hardened and tempered square blade offered in inch, millimeter, and inch and millimeter combined
- Reversible lock bolt allows the blade to be turned over or end-for-end so that all four graduated edges may be used
- The combination square, as its name indicates, handles many jobs, saving the apprentice from buying more individual tools. This combination square can be used as a try square, 45° miter, a depth gage, a height gage, a layout tool, and as a rule.
- Optional center head is available to increase the versatility of this universal measuring tool

| Inch | | | |
|---------------------|-------|-------------------------------|--|
| Cat. No. | EDP | Size | Graduation |
| 10H-6-4R | 64942 | 6" | 4R – 8ths, 16ths, Quick Reading 32nds, 64ths |
| Millimeter | | | |
| Cat. No. | EDP | Size | Graduation |
| 10MH-150 | 64943 | 150mm | mm and 1/2mm Both Sides |
| Inch and Millimeter | | | |
| Cat. No. | EDP | Size | Graduation |
| 10MEH-150 | 64944 | 5-3/4" (150mm) | 1/2mm and 32nds One Side mm and 64ths Reverse Side |
| Center Head Only | | | |
| Cat. No. | EDP | Description | |
| C11-6 | 50073 | Center Head to Fit 10 Squares | |

* Max. Inspect Diameter: 4.3"

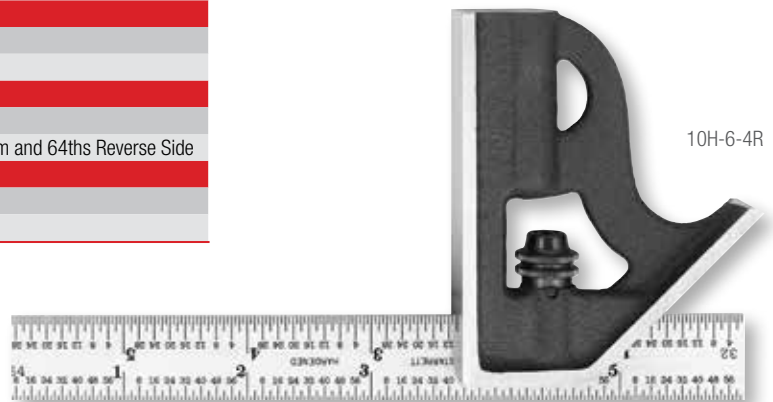

COMBINATION SQUARES

33J JUNIOR COMBINATION SQUARES

6"

These squares are used by mechanics, toolmakers and patternmakers because of their compact, small size and light weight. Both blade and heads are smaller than on regular squares. Heads are drop forged, hardened steel and have smooth, black enamel finish. Blades 4" long may be ordered individually as listed below. Blades are furnished in regular finish, except where indicated.

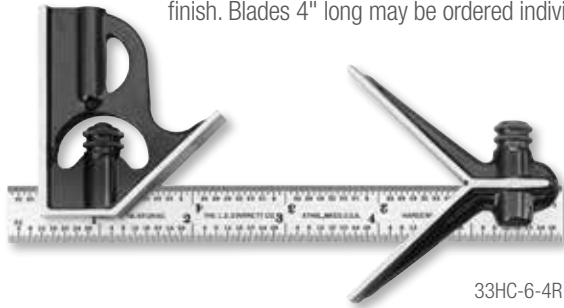

33HC-6-4R



33J Junior Combination Squares

| Cat. No. | EDP | Blade Length | Graduation | Description |
|-------------|-------|--------------|--|----------------------------------|
| 33JH-6-4R | 50229 | 6" | 4R – 8ths, 16ths, Quick Reading 32nds, 64ths | With Square Head Only |
| 33JH-6-16R | 50231 | | 16R – Quick Reading 32nds, 64ths, Aircraft Quick Reading 50ths, 100ths | |
| 33JHC-6-4R | 50230 | 6" | 4R – 8ths, 16ths, Quick Reading 32nds, 64ths | With Square Head and Center Head |
| 33JHC-6-16R | 50232 | | 16R – Quick Reading 32nds, 64ths, Aircraft Quick Reading 50ths, 100ths | |

Blades Only

| Cat. No. | EDP | Blade Length | Graduation | Description |
|------------|-------|--------------|--|-------------|
| B33J-4R | 50235 | 6" | 4R – 8ths, 16ths, Quick Reading 32nds, 64ths | Blade |
| CB33J-4R* | 67100 | | | |
| B33J-16R | 50236 | 6" | 16R – Quick Reading 32nds, 64ths, Aircraft Quick Reading 50ths, 100ths | Blade |
| CB33J-16R* | 67101 | | | |
| B4-4R | 50076 | 4" | 4R – 8ths, 16ths, Quick Reading 32nds, 64ths | Blade |
| CB4-4R* | 50077 | | | |
| CB4-16R* | 50078 | | 16R – Quick Reading 32nds, 64ths, Aircraft Quick Reading 50ths, 100ths | |

Heads Only

| Cat. No. | EDP | Description |
|----------|-------|---------------|
| H33-4 | 50223 | Square Head |
| C33-4 | 50226 | Center Head** |

* Blade in satin chrome finish.
 ** Max. Inspect Diameter - 3.125"

439 BUILDERS' COMBINATION TOOL

18" AND 24"

This versatile tool is invaluable for carpenters, builders, patternmakers, cabinet makers and all mechanics.

FEATURES

- Combines seven tool functions in one compact, practical unit. It is a rule, square, level, plumb, protractor, bevel and pitch-to-foot indicator.
- It consists of a stock, 9" (230mm) long, a hardened, photo-engraved 1-1/2" (38mm) wide blade in 18" or 24" lengths, and a protractor
- On one side the protractor is graduated from zero to 90° in both directions show the direct and supplementary angles. The other side is graduated in 1/2" pitch increments from 0-12" per foot pitch.
- The stock has four levels which permits leveling or plumbing the work in relation to any to any angle or pitch
- Tool is ideal for laying out or cutting valleys or hips of different pitches, done as follows: Rotate the blade to the desired pitch, place the face of the stock against the work and draw a line. Then place the square end of the stock against the line and draw the complementary line. This gives the complementary angle automatically, without calculation.

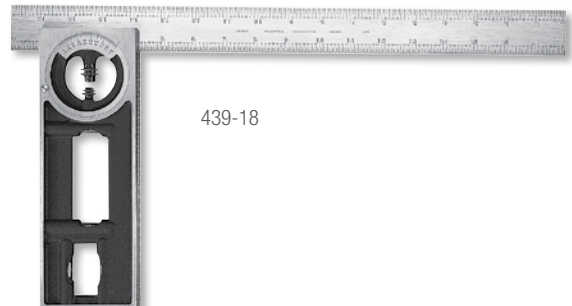

439-18

| Cat. No. | EDP | Blade Length | Blade Graduation | Head Graduation | |
|----------|-------|--------------|--------------------------------|-----------------|---------------|
| | | | | Degrees | Pitch |
| 439-18 | 52110 | 18" | 4R - 8ths, 16ths, 32nds, 64ths | 0-90° | 0-12" per ft. |
| 439-24 | 52111 | 24" | | | |



MASTER PRECISION SQUARES

20 MASTER PRECISION SQUARES

1-1/2-36"/40-910MM

The finest precision-checking squares – not graduated. Squareness accuracy to .0001" (0.0025mm) every 6" (150mm).

These hardened steel squares are used when extreme accuracy is required. The beams and blades are hardened, ground and lapped to ensure parallelism and straightness. The beam is grooved at the inner corner for clearance of burr or dirt. Made of high quality tool steel, with the finest of craftsmanship throughout.

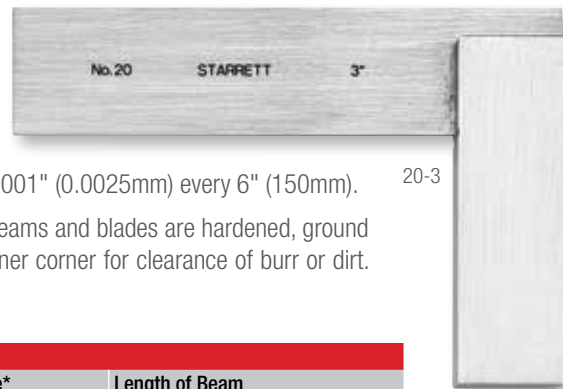

20-3

20 Master Precision Squares

| Squares Only | | Case Only | | Size – Length of Blade* | | Length of Beam | |
|--------------|-------|-----------|-------|-------------------------|-----|----------------|-----|
| Cat. No. | EDP | Cat. No. | EDP | in | mm | in | mm |
| 20-1 1/2 | 50128 | 916 | 55152 | 1-1/2 | 40 | 1-1/2 | 40 |
| 20-3 | 50130 | 951 | 55153 | 3 | 75 | 2-3/8 | 60 |
| 20-4 1/2 | 50132 | 918 | 55154 | 4-1/2 | 115 | 3-1/2 | 90 |
| 20-6 | 50134 | 919 | 55155 | 6 | 150 | 4-5/16 | 110 |
| 20-6 W/SLC‡ | 66899 | | | | | | |
| 20-12 | 50136 | 20ZZ-12 | 55156 | 12 | 300 | 7 | 180 |
| 20-12 W/SLC‡ | 66900 | | | | | | |
| 20-24 | 50140 | 20ZZ-24† | 55158 | 24 | 600 | 12-5/16 | 310 |
| 20-36** | 50142 | 20ZZ-36† | 55159 | 36 | 910 | 20 | 500 |

Larger squares can be furnished; quoted on application.

* Length of blade from the inner edge of the beam to the end of the blade.

** 36" (910mm) and larger size squares have special screws to secure the blade to the beam.

† Rack-type case.

‡ Includes redemption card for Standard Letter of Certification (SLC).

55 MASTER PRECISION SQUARES WITH BEVELED EDGES

1-1/2-6"/40-150MM

These 55 Hardened Steel Squares are the same as the 20 Squares described above, except that the blades are beveled on both edges of each side, which provides an excellent visual line contact with the work.

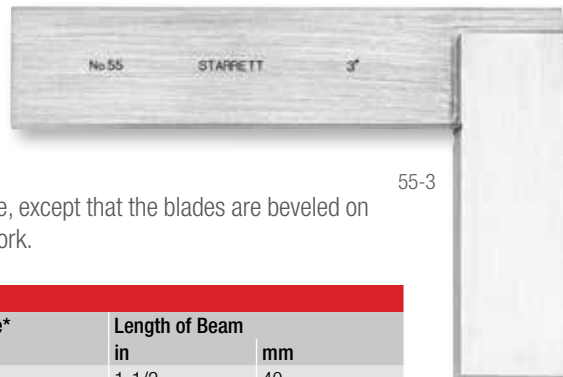

55-3

55 Master Precision Squares with Beveled Edges

| Squares Only | | Case Only | | Size – Length of Blade* | | Length of Beam | |
|--------------|-------|-----------|-------|-------------------------|-----|----------------|-----|
| Cat. No. | EDP | Cat. No. | EDP | in | mm | in | mm |
| 55-1 1/2 | 50277 | 916 | 55152 | 1-1/2 | 40 | 1-1/2 | 40 |
| 55-3 | 50279 | 951 | 55153 | 3 | 75 | 2-3/8 | 60 |
| 55-4 1/2 | 50281 | 918 | 55154 | 4-1/2 | 115 | 3-1/2 | 90 |
| 55-6 | 50283 | 919 | 55155 | 6 | 150 | 4-5/16 | 110 |

* Length of blade from the inner edge of the beam to the end of the blade.



SQUARES

SQUARES

3020 TOOLMAKERS' GRADE STAINLESS STEEL SQUARES

2-31/32 - 12-1/32"/50-175MM

This high quality toolmakers' square is not graduated and offers squareness accuracy to .0002" (0.005mm) for every 6" (150mm).

They feature hardened, ground and lapped stainless steel construction on both the blade and the beam. The beam is machined at the inner corner for clearance of burr or dirt.

Packed one in a plastic case. 12" square and set of 4 squares shipped in box with fitted foam insert. Wood cases as listed may be purchased separately.

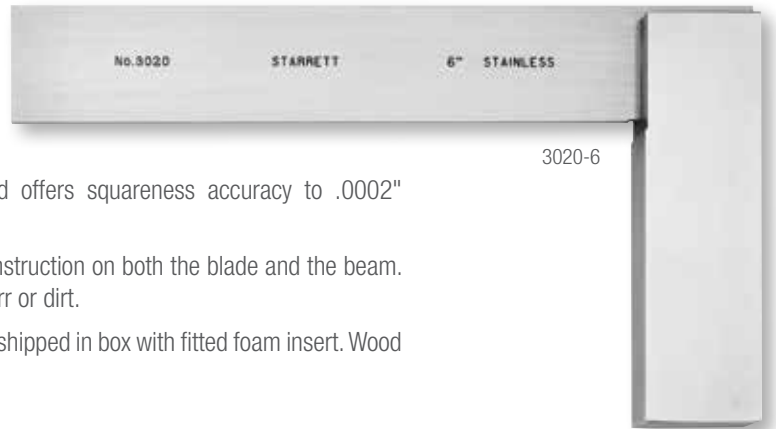

3020-6

3020 Toolmakers' Grade Stainless Steel Squares

| Squares Only | | Case Only | | Size – Length of Blade* | | Length of Beam | |
|--------------|-------|-----------|-------|-------------------------|-----|----------------|-----|
| Cat. No. | EDP | Cat. No. | EDP | in | mm | in | mm |
| 3020-3 | 12225 | 951 | 55153 | 2-31/32 | 75 | 1-31/32 | 50 |
| 3020-4 | 12226 | 918 | 55154 | 3-31/32 | 100 | 2-31/32 | 75 |
| 3020-6 | 12227 | 919 | 55155 | 5-29/32 | 150 | 3-29/32 | 100 |
| 3020-12 | 12228 | 20ZZ-12 | 55156 | 12-1/32 | 300 | 6-7/8 | 175 |

3020 Sets

| Cat. No. | EDP | Description |
|----------|-------|-------------------------------|
| S3020Z | 12229 | Complete Set of all 4 Squares |

* Length of blade from the inner edge of the beam to the end of the blade.

61 "RELIABLE" TRY SQUARE

6"/150MM

A very useful try square – attractively designed, light and convenient. The blade is hardened, not graduated, and is firmly held by a special bolt and nut permitting the tool to be readily taken apart, if desired, for regrounding the blade and stock.

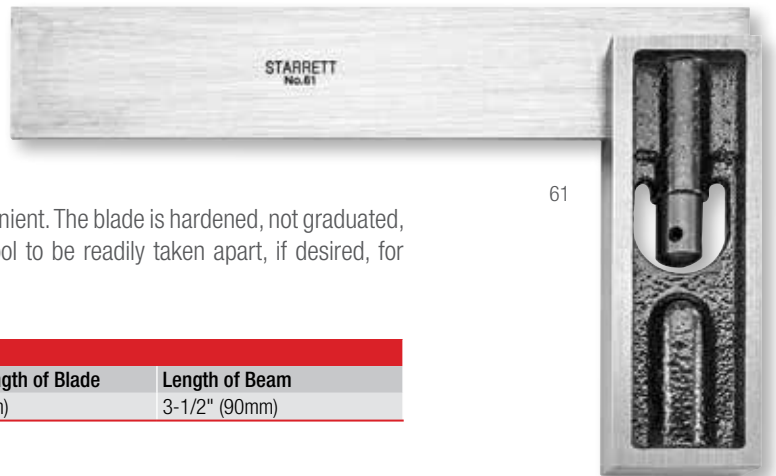

61

61 "Reliable" Try Square

| Cat. No. | EDP | Size – Length of Blade | Length of Beam |
|----------|-------|------------------------|----------------|
| 61 | 50303 | 6" (150mm) | 3-1/2" (90mm) |



DOUBLE SQUARES

13. 13M DOUBLE SQUARES WITH HARDENED BLADES

4-6"/100-150MM

These squares are very popular with machinists, toolmakers, and patternmakers. The sliding blades are adjustable making it practical for a wide variety of uses. The faces of the head are ground square, and the 6" (150mm) size has a level.

The bevel blade is available, featuring an octagon angle 45° at one end and a hexagon angle 60° at the other end, clearly marked.

A drill grinding blade, also available for 6" (150mm) squares, is beveled to 59° for drill grinding on one end and 41° (the cutting angle of countersinks for machine screws) at the other. Both ends have quick-reading 64ths grads. and the graduation is located to measure perpendicularly to the axis of the drill. By reading the graduations, the center point can be easily and accurately located.

The 6" square head used with the drill grinding blade is approximately 3-1/2" (90mm) long, and the faces approximately 9/16" (14mm) wide.

| Inch Reading Double Squares – 4R Graduation – 8ths, 16ths, 32nds, 64ths | | | |
|---|-------|-------|--|
| Cat. No. | EDP | Size | Description |
| 13A | 50109 | 4" | With graduated blade only |
| 13C | 50111 | 6" | With graduated blade only |
| 13E | 50112 | 6" | With graduated and bevel blades |
| 13D | 50114 | | Drill grinding blade only for 6" (150mm) squares |
| Millimeter Reading Double Squares – mm Both Edges One Side; mm and 1/2mm Reverse Side | | | |
| Cat. No. | EDP | Size | Description |
| 13MA | 56278 | 100mm | With graduated blade only |
| 13MB | 56279 | 100mm | With graduated and bevel blades |
| 13MC | 56280 | 150mm | With graduated blade only |
| 13ME | 56263 | 150mm | With graduated and bevel blades |

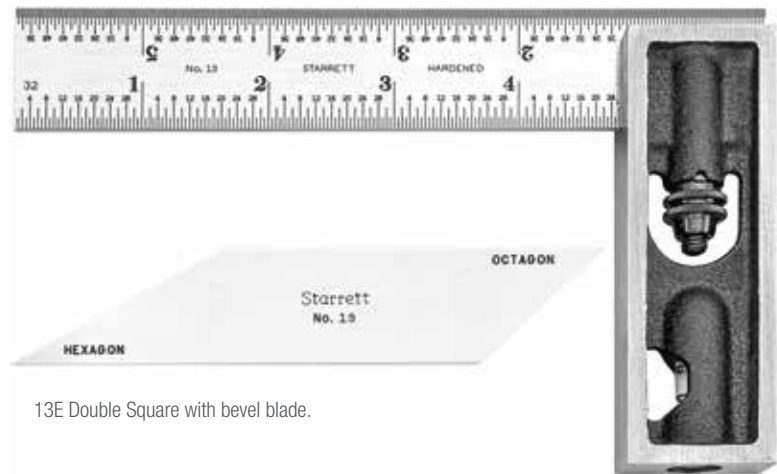

13E Double Square with bevel blade.

DOUBLE SQUARES

14, 14M Double Steel Squares with Hardened and Ground Head and Blades

2-1/2"/50MM

Designed for tool and diemakers, these fine precision double steel squares have adjustable blades, ideal for tight fits. A knurled clamping nut accurately locks the blades in any position.

Beveled blade is 45° on one end and 30° on the other.

2-1/4" (58mm) Narrow blade has 32nds and 64ths graduations. It is 5/32" (4mm) wide over a length of approximately 1-5/8" (41mm) and cut away at one end to a width of 3/32" (2.4mm).

| 14 Inch Reading Double Steel Squares – 32nds, 64ths | | | | |
|--|-------|--------|--------------|--|
| Cat. No. | EDP | Size | Graduation | Description |
| 14A | 50117 | 2-1/2" | 32nds, 64ths | With Graduated Blade Only |
| 14D | 50118 | | | Complete with Graduated Narrow Blade and Bevel Blade |
| 14M Millimeter Reading Double Steel Squares– mm Both Edges One Side; mm and 1/2mm Reverse Side | | | | |
| Cat. No. | EDP | Size | Graduation | Description |
| 14MA | 56260 | 50mm | mm, 1/2mm | With Graduated Blade Only |
| 14MD | 56261 | | | Complete with Graduated Narrow Blade and Bevel Blade |

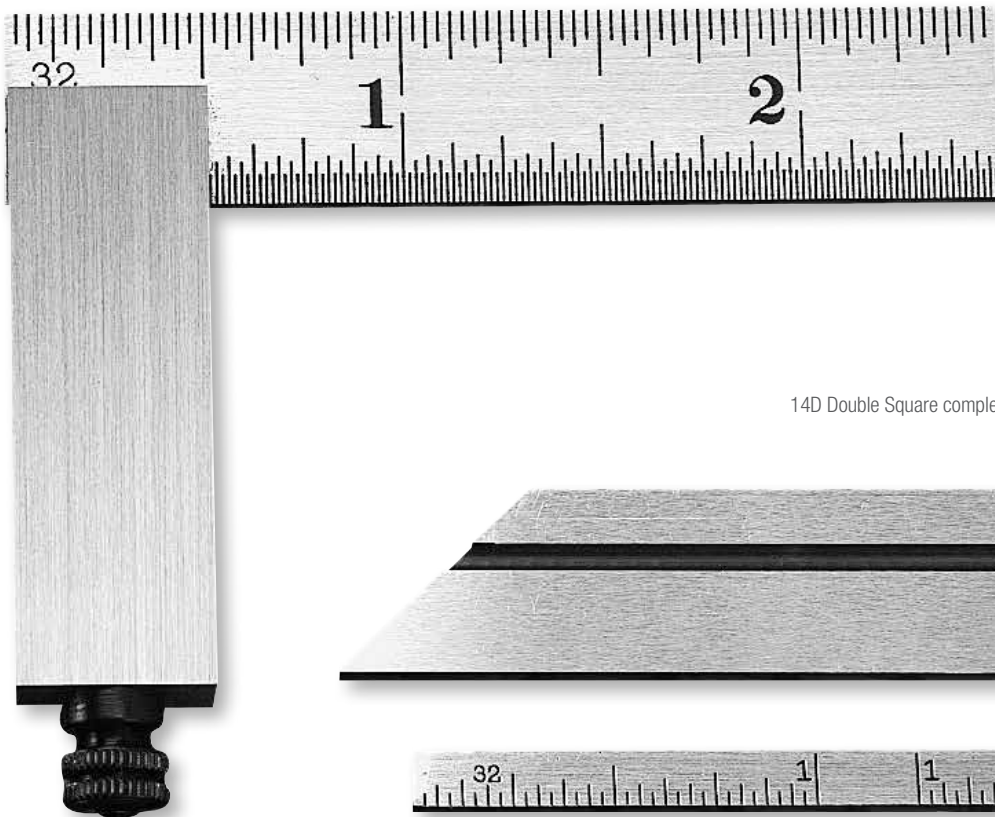

14D Double Square complete with graduated, bevel and narrow blades.



DIEMAKERS' SQUARES

453, 453M DIEMAKERS' SQUARES WITH ANGULAR AND SLIDING BLADE ADJUSTMENT

2-1/2"/50MM

The sliding blades of this tool and diemakers' square can be adjusted at an angle (up to approximately 10°) with the beam for measuring the clearance in dies (see sectional view). The larger knurled thumb screw locks the blades at any position, and the smaller one tilts the blades at an angle. To set the blades at an angle, first release the blade clamp screw, then the blade may be tilted to the desired angle by turning the small knurled screw into the beam. The blade can be held in position by tightening the clamping screw. Head and blades are hardened and ground.

The inch reading blade is graduated on one side, upper edge in 32nds, lower edge in 64ths and the millimeter reading blade is graduated in millimeters and 1/2 millimeters.

The bevel blade is approximately 2-1/2" (63mm) long x 1/2" (12.5mm) wide and is beveled to 30° on one end and 45° on the other.

The narrow graduated blade has 32nds graduation on one side, and 64ths on the other. It is 5/32" (4mm) wide over a length of approximately 1-5/8" (41mm) and cut away at one end to a width of 3/32" (2.4mm).

The offset blade is used where it would be impossible to sight a straight blade. It protrudes from the square about 1-1/2" (38mm) and is 1/8" (3mm) wide. Both sides of each edge are beveled to provide good visual line contact.

| 453 Inch Reading Diemakers' Squares – Graduation 32nds, 64ths | | | |
|--|-------|--------|---|
| Cat. No. | EDP | Size | Description |
| 453A | 52345 | 2-1/2" | With Standard Graduated Blade |
| 453C | 52347 | | With Standard, Narrow Blades |
| 453E | 52349 | | Complete With Standard, Bevel, Narrow and Offset Blades |
| 453EZ | 52351 | | Complete With Standard, Bevel, Narrow and Offset Blades in Case |
| 453M Millimeter Reading Diemakers' Squares – Graduation mm and 1/2mm | | | |
| Cat. No. | EDP | Size | Description |
| 453MA | 52346 | 50mm | With Standard Graduated Blade |
| 453MC | 52348 | | With Metric Standard, Narrow Blades |

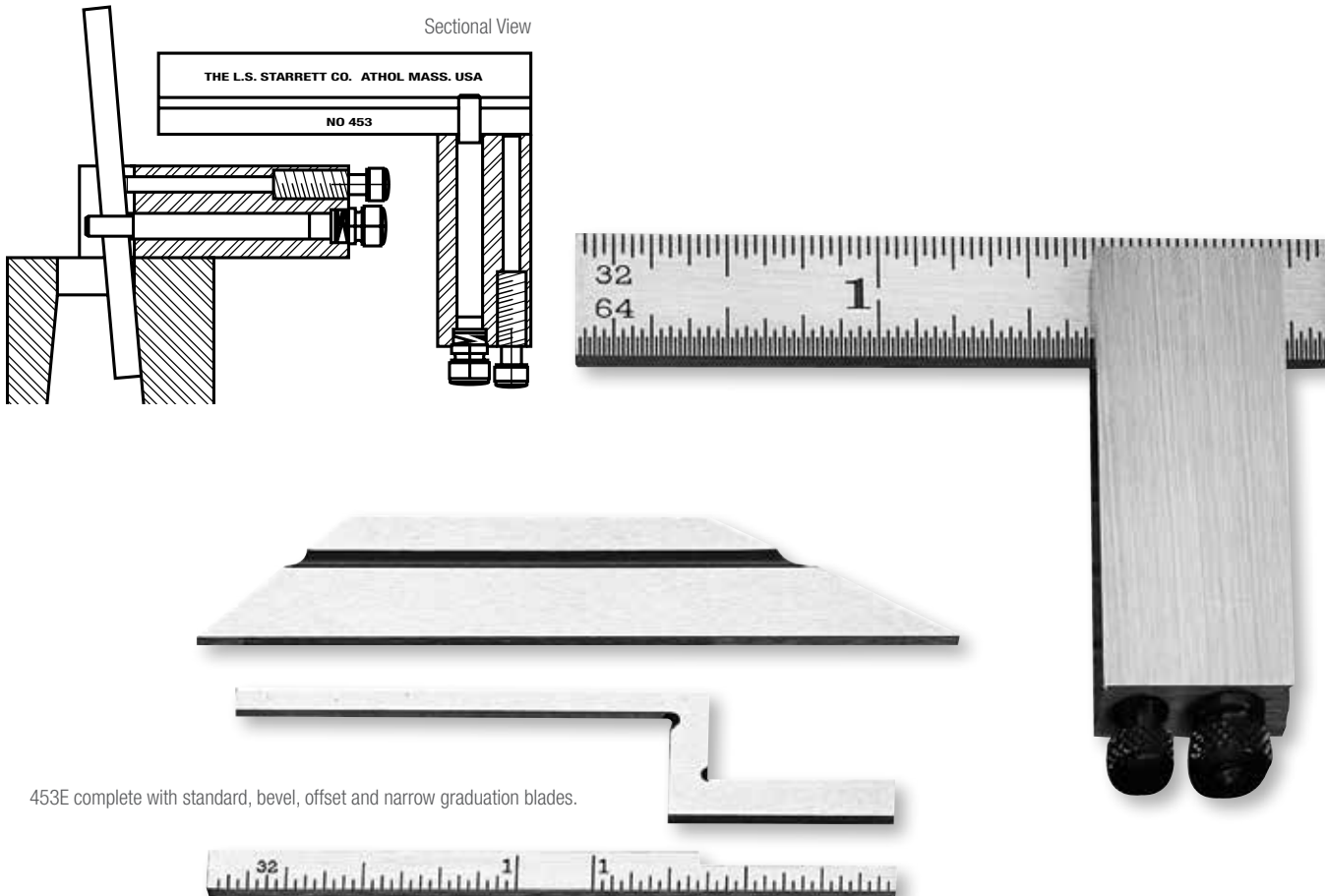

453E complete with standard, bevel, offset and narrow graduation blades.



DIEMAKERS' SQUARES

457 IMPROVED DIEMAKERS' SQUARE WITH ANGULAR ADJUSTMENT

10°-0°-10°

The 457 Improved Diemakers' Square is a highly useful tool for tool and diemakers, especially for measuring die clearances. It is also very handy for patternmakers to check angles and drafts on patterns.

The beam of this square is graduated to show the setting in degrees of the blades. Blades can be set for any angle up to 10°, either side of 0° and the angle is indicated by the line on the pointer.

The graduated blade has 32nds of an inch on one side, and 64ths on the other. It is 5/32" (4mm) wide over a length of approximately 1-5/8" (41mm) and cut away at one end to a width of 3/32" (2.4mm).

The offset blade, which is used where it would be impossible to insert the straight blade, protrudes from the square about 1-1/2" (38mm). It is 1/8" (3mm) wide and both sides of each edge are beveled to give visual line contact.

The beam is beveled adjacent to the blade so that the blade is readily visible when checking in holes, slots, etc. Blades and beams are hardened and ground.

Angular Range 10°-0°-10°

| Cat. No. | EDP | Description |
|----------|-------|---|
| 457A | 52428 | With Straight Blade Only |
| 457C | 52429 | Complete, with Straight and Offset Blades |

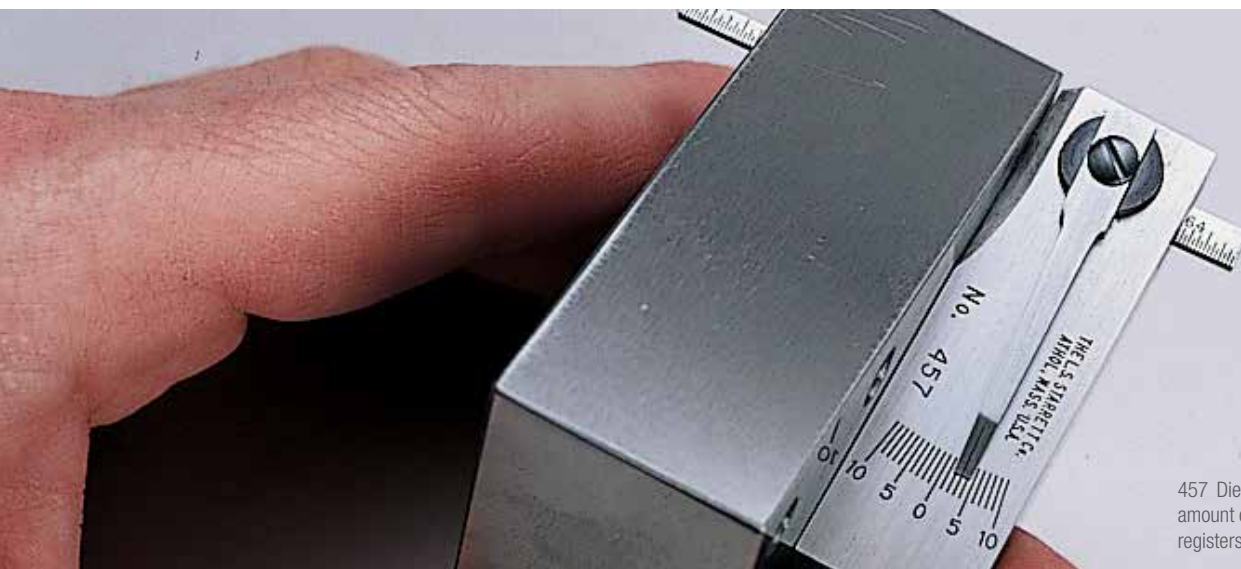
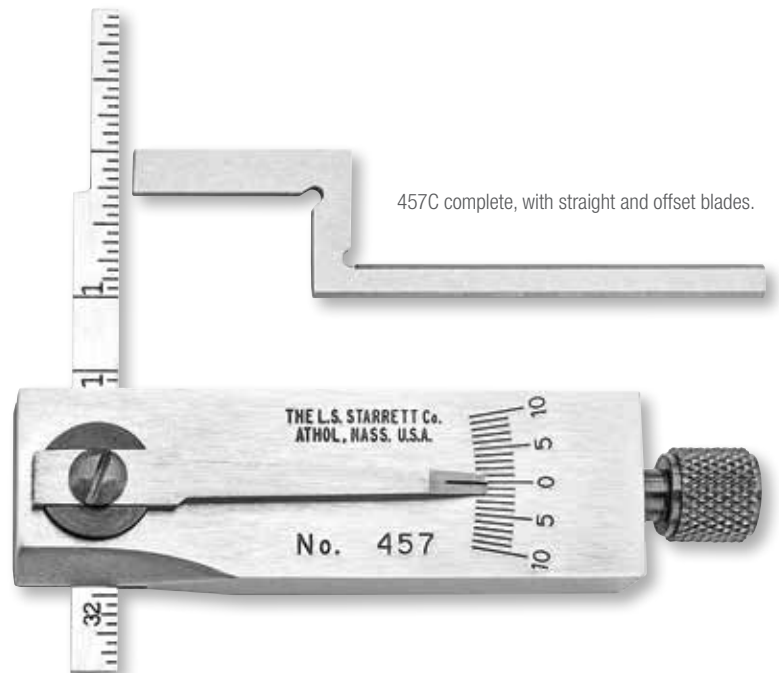

457 Diemakers' Square is used to determine amount of clearance in this die. Movable pointer registers clearance in degrees.



**PRECISION RULES,
STRAIGHT EDGES, PARALLELS**

PRECISION RULES

PRECISION STEEL RULES

Starrett rules are made from fine quality steel and produced to the highest precision standards, making them the most accurate and readable precision steel rules available. Through over 130 years of experience, we have developed the following versatile features, designs and styles:

OUR PRODUCT LINE CONSISTS OF:

- Full-flexible 1/64" - 1/50" (0.4-0.5mm) thick
- Semi-flexible 1/50-1/40" (0.5-0.6mm) thick
- Spring-tempered 3/64" (1.2mm) thick
- Heavy spring-tempered 1/10" (2.5mm) thick
- Stainless steel 1/64" or 3/64" (0.4 or 1.2mm) thick
- Graduation styles are inch, millimeter, inch and millimeter, shrink, and special graduations
- All rules are photo-engraved and tempered for long life and flexibility



Rule with Aircraft Quick-Reading Graduations on lower edge



Rule with Quick-Reading Graduations on both edges



ACCURACY

- All of our precision steel rules are photo-engraved
- We inspect to Starrett Master Standards, which are traceable to the National Institute of Standards and Technology
- Measuring Tip: When using a precision rule for very close accuracy, the eye can read better by measuring between two lines rather than from the end of the rule to a line

READABILITY FEATURES

- The numbering size and style is distinctive and more readable than ordinary rules
- Advanced, staggered graduations- When reading lines, it is much easier to count lines of differing lengths than those that resemble a comb. All Starrett graduations are staggered in a height pattern that makes reading easy. For reading very fine graduations such as 50ths (.020") or 100ths (.010") of an inch, Starrett designed an improved pattern of lines called "Aircraft Quick-Reading Graduations" (see photo). The name stems from its extreme popularity in aircraft plants and other shops using decimals. This pattern is also used on some of our millimeter rules.
- Quick-reading figures are furnished with finer graduations for easier counting. Most all inch graduations of 1/32" and finer have subdivisions numbered (see photo).
- All rules are available in Starrett no-glare satin chrome finish for easier reading and rust resistance
- There are still some old "D" style rules on the market. These have one square and one rounded end. All Starrett rules are ground square on both ends. This provides better efficiency through the ability to read from either end on all edges.



PRECISION RULES

USEFUL VARIATION FEATURES OF OUR STANDARD PRECISION RULES

END GRADUATIONS

End graduations are useful for measuring depths, widths of shoulders, recesses, grooves, etc. They are graduated in 32nds of an inch or millimeters on both ends of one side as shown at the right.



End Graduations

ADJUSTABLE STEEL HOOK RULES

These improved Hook Rules feature an adjustable double hook that can be shortened or extended on either side in relation to any one of the four graduations on the rule. This allows accurate measurements from shallow or deep shoulders and also permits setting inside calipers to any of the graduations. Hooks are hardened and may be adjusted or removed by a slight turn of an eccentric stud.



Adjustable Steel Hook Rule

STEEL HOOK RULES WITH REVERSIBLE HOOK

These convenient Hook Rules permit accurate measurements, even when the user cannot see if the rule is aligned with the measuring edge. This is especially useful for measuring from round corners, through hubs, for setting inside calipers, etc. The single hook is hardened and may be reversed or removed by a slight turn of an eccentric stud.



Steel Hook Rule with Reversible Hook

NARROW HOOK RULES WITH REVERSIBLE HOOK

These useful Hook Rules are similar to the Hook Rules described above, but have a narrow blade (only 3/16" [4.8mm] wide) which permits measurements through holes as small as 7/32" (5.5mm) in diameter. Hooks are hardened and may be reversed or removed by a partial turn of the eccentric stud.



Narrow Hook Rule with Reversible Hook

STEEL RULE WITH TAPERED END

This 6" rule, our C310T-6, is a favorite with all mechanics because the tapered end permits measuring insides of small holes, narrow slots, grooves, recesses, etc. The rule has a taper from 1/2" width at the 2" graduation to 1/8" width at the end. Accurate, distinctive, photo-engraved graduations in 32nds are on one side and 64ths on the reverse side, with graduations always in a normal, easy-to-read position. Made of tempered, full-flexible steel with satin chrome finish.



Steel Rule with Tapered End

STEEL RULE WITH POCKET CLIP

This handy 6" rule is designed for frequent use. It is made of tempered, full-flexible steel and has accurate, photo-engraved graduations in 32nds on one edge and 64ths on the opposite edge, with satin chrome finish. C310K-6.



Steel Rule with Pocket Clip

PRECISION RULES, STRAIGHT EDGES, PARALLELS

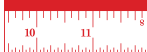

PRECISION RULES

INCH GRADUATION STYLES

1

First Edge: 10ths, 20ths, 50ths, 100ths



Second Edge: 12ths, 24ths, 48ths



Fourth Edge: 14ths, 28ths

Third Edge: 16ths, 32nds, 64ths

3R*

First Edge: 32nds



Second Edge: 64ths

Fourth Edge: 10ths



Third Edge: 50ths

4R*

First Edge: 64ths



Second Edge: 32nds

Fourth Edge: 8ths



Third Edge: 16ths

5R*

First Edge: 10ths



Second Edge: 100ths

Fourth Edge: 32nds



Third Edge: 64ths

6R*

First Edge: 50ths



Second Edge: 50ths

Fourth Edge: 10ths



Third Edge: 10ths

* Suffix "R" designates Quick-Reading graduations

NOTE: All rules under 1" in width have single row of inch figures. Rules 1" and wider have double row of inch figures, and each edge represents the bottom edge reading left to right.



PRECISION RULES

INCH GRADUATION STYLES

7R*

First Edge: 100ths



Second Edge: 64ths

Fourth Edge: 32nds



Third Edge: 16ths

9R*

First Edge: None



Second Edge: 64ths

Fourth Edge: 16ths



Third Edge: 32nds

10R*

First Edge: 64ths



Second Edge: 32nds

NO.11

First Edge: None
Second Edge: 100ths



Third Edge: None
Fourth Edge: 64ths



16R*

First Edge: 50ths



Second Edge: 100ths

Fourth Edge: 32nds



Third Edge: 64ths

* Suffix "R" designates Quick-Reading graduations

NOTE: All rules under 1" in width have single row of inch figures. Rules 1" and wider have double row of inch figures, and each edge represents the bottom edge reading left to right.

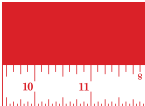

STEEL RULES

STEEL RULES WITH INCH GRADUATIONS

1-144"

All rules furnished with Starrett satin chrome finish, except where noted. Additional sizes and variations available by special order.

RULES INCLUDE

- Full-Flexible
- Semi-Flexible
- Spring-Tempered
- Heavy Spring-Tempered

| Key to Starrett Rule Numbering System | |
|---------------------------------------|---------------------|
| Prefixes | |
| C | Satin Chrome Finish |
| DH | Double Hook |
| H | Single Hook |
| Suffixes | |
| E | End Graduations |
| K | With Pocket Clip |
| N | Narrow-Type Rule |
| R | Quick-Reading |
| S | Semi-Flexible |
| T | Tapered End |

| 1-4" Spring-Tempered Steel Rules with Inch Graduations | | | | | |
|--|-------|--------|-------------------|---|--|
| Cat. No. | EDP | Length | Width x Thickness | Graduations | Feature Remarks |
| C604R-1* | 56464 | 1" | | | |
| C604R-2* | 56465 | 2" | 1/2 x 3/64" | 4R – 8ths, 16ths, Quick-Reading 32nds, 64ths | |
| C604R-3* | 56466 | 3" | 9/16 x 3/64" | 4R – 8ths, 16ths, Quick-Reading 32nds, 64ths | |
| C604R-4* | 56467 | 4" | 5/8 x 3/64" | 4R – 8ths, 16ths, Quick-Reading 32nds, 64ths | |
| 6" Full-Flexible Steel Rules with Inch Graduations | | | | | |
| Cat. No. | EDP | Length | Width x Thickness | Graduations | Feature Remarks |
| C303R-6* | 51334 | 6" | 1/2 x 1/64" | 3R – Quick-Reading 10ths, Aircraft Quick-Reading 50ths, 32nds and 64ths | |
| C304R-6* | 66008 | 6" | 1/2 x 1/64" | 4R – 8ths, 16ths, Quick-Reading 32nds and 64ths | |
| C305R-6* | 51347 | 6" | 1/2 x 1/64" | 5R – Quick-Reading 10ths, Aircraft Quick-Reading 100ths, 32nds and 64ths | |
| C305R-6 W/SLC* | 66880 | 6" | 1/2 x 1/64" | | With Standard Letter of Certification† |
| C306R-6* | 51352 | 6" | 1/2 x 1/64" | 6R – One Side Only – Quick-Reading 10ths (.10) Top Edge; Aircraft Quick-Reading 50ths (.02) Bottom Edge | |
| C309R-6* | 51357 | 6" | 1/2 x 1/64" | 9R – 16ths and Quick-Reading 32nds on One Side; Quick-Reading 64ths on Reverse Side | |
| C310R-6* | 51368 | 6" | 1/2 x 1/64" | 10R – Quick-Reading 32nds, 64ths on One Side Only | |
| C310K-6* | 56701 | 6" | 1/2 x 1/64" | 10 – 32nds and 64ths on One Side Only | With Pocket Clip |
| C310T-6* | 56700 | 6" | 1/2 x 1/64" | 10 – 32nds One Side; 64ths on Reverse Side | With Tapered End |
| C316R-6* | 51374 | 6" | 1/2 x 1/64" | 16R – Quick-Reading 32nds, 64ths, Aircraft Quick-Reading 50ths and 100ths | |
| 1309R-6* | 53204 | 6" | 1/2 x 1/64" | 9R – 16ths and Quick-Reading 32nds on One Side; Quick-Reading 64ths on Reverse Side | Stainless Steel |
| 6" Semi-Flexible Steel Rules with Inch Graduations | | | | | |
| Cat. No. | EDP | Length | Width x Thickness | Graduations | Feature Remarks |
| C303SR-6* | 51335 | 6" | 3/4 x 1/50" | 3R – Quick-Reading 10ths, Aircraft Quick-Reading 50ths, 32nds and 64ths | |
| C304SRE-6* | 51343 | 6" | 3/4 x 1/50" | 4R – 8ths, 16ths, Quick-Reading 32nds and 64ths; End Graduations in 32nds Both Ends, One Side | End Graduations |

† Includes redemption card for Standard Letter of Certification (SLC).

*Indicates rules with single row of inch figures (all rules under 1" width). Rules without asterisk have double row of inch figures, and each edge represents the bottom edge reading left to right (rules 1" and wider).

H604R-6 with Reversible Hook



STEEL RULES

STEEL RULES WITH INCH GRADUATIONS

1-144"

All rules furnished with Starrett satin chrome finish, except where noted.
Additional sizes and variations available by special order.

RULE CASE OPTIONS

- Protective case with see through front (standard)
- Leather-like case with pocket clip (optional)

Cases for 6" (150mm) Rules

| Cat. No. | EDP | Description |
|----------|-------|---|
| 1612 | 55433 | Case with Clip for 1/2" (12.7mm) Wide Rules |
| 1634 | 55434 | Case with Clip for 3/4" (19mm) Wide Rules |

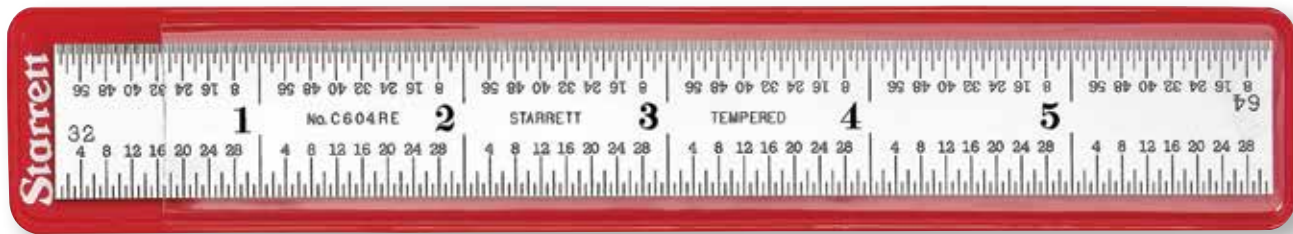

1612

6" Spring-Tempered Steel Rules with Inch Graduations

| Cat. No. | EDP | Length | Width x Thickness | Graduations | Feature Remarks |
|----------------|-------|--------|-------------------|---|---|
| C601-6* | 52639 | 6" | 3/4 x 3/64" | 1 – 10ths, 20ths, 50ths, 100ths; 12ths, 24ths, 48ths; 16ths, 32nds, 64ths; 14ths, 28ths | See Below** |
| 604R-6* | 52645 | | | | Regular Steel Finish |
| C604R-6* | 52678 | 6" | 3/4 x 3/64" | 4R – 8ths, 16ths, Quick-Reading 32nds and 64ths | With Standard Letter of Certification† |
| C604R-6 W/SLC* | 66884 | | | | |
| C604RE-6* | 52660 | 6" | 3/4 x 3/64" | 4R – 8ths, 16ths, Quick-Reading 32nds and 64ths End Graduations in 32nds Both Ends, One Side | End Graduations |
| H604R-6* | 52667 | | | | Regular Steel Finish; With Reversible Hook |
| CH604R-6* | 52673 | 6" | 3/4 x 3/64" | 4R – 8ths, 16ths, Quick-Reading 32nds and 64ths | With Reversible Hook |
| DH604R-6* | 52662 | | | | Regular Steel Finish; With Adjustable Double Hook |
| CD604R-6* | 52665 | | | | With Adjustable Double Hook |
| C606R-6* | 52652 | 6" | 3/4 x 3/64" | 6R – Both Sides – Aircraft Quick-Reading 50ths (.02) Both Edges One Side, Quick-Reading 10ths (.10) Both Edges, Opposite Side | |
| C607R-6* | 52688 | 6" | 3/4 x 3/64" | 7R – 16ths, Quick-Reading 32nds, 64ths, Aircraft Quick-Reading 100ths | |
| C616R-6* | 52701 | 6" | 3/4 x 3/64" | 16R – Quick-Reading 32nds, 64ths, Aircraft Quick-Reading 50ths, 100ths | |
| 1604R-6* | 53210 | 6" | 3/4 x 3/64" | 4R – 8ths, 16ths, Quick-Reading 32nds and 64ths | Stainless Steel |
| 610N-6* | 52694 | | | | Regular Steel Finish; Narrow Rule |
| C610N-6* | 52696 | 6" | 3/16 x 3/64" | 10 – 32nds One Side and 64ths on Reverse Side | Narrow Rule |
| H610N-6* | 52697 | | | | Regular Steel Finish; Narrow Rule with Hook |
| CH610N-6* | 52699 | | | | Narrow Rule with Hook |
| 611N-6* | 52700 | 6" | 3/16 x 3/64" | 11 – 64ths on One Side and 100ths on Reverse Side | Regular Steel Finish; Narrow Rule |

†Includes redemption card for Standard Letter of Certification (SLC).

*Indicates rules with single row of inch figures (all rules under 1" width). Rules without asterisk have double row of inch figures, and each edge represents the bottom edge reading left to right (rules 1" and wider).

**1 pattern has 12 different grads., many that are not found on usual rules. This allows the rule to be used for various purposes like laying out and cutting gear teeth (not generally used today).



STEEL RULES

STEEL RULES WITH INCH GRADUATIONS

1-144"

All rules furnished with Starrett satin chrome finish, except where noted. Additional sizes and variations available by special order.

12" Full-Flexible Steel Rules with Inch Graduations

| Cat. No. | EDP | Length | Width x Thickness | Graduations | Feature Remarks |
|-----------------|-------|--------|-------------------|---|--|
| C304R-12* | 66009 | 12" | 1/2 x 1/64" | 4R – 8ths, 16ths, Quick-Reading 32nds and 64ths | |
| C305R-12* | 51348 | 12" | 1/2 x 1/64" | 5R – Quick-Reading 10ths, Aircraft Quick-Reading 100ths, 32nds and 64ths | With Standard Letter of Certification† |
| C305R-12 W/SLC* | 66881 | 12" | 1/2 x 1/64" | 5R – Quick-Reading 10ths, Aircraft Quick-Reading 100ths, 32nds and 64ths | |
| C306R-12* | 51353 | 12" | 1/2 x 1/64" | 6R – One Side Only – Quick-Reading 10ths (.10) Top Edge; Aircraft Quick-Reading 50ths (.02) Bottom Edge | |
| C310R-12* | 56429 | 12" | 1/2 x 1/64" | 10R – Quick-Reading 32nds and 64ths One Side Only | |
| C316R-12* | 51375 | 12" | 1/2 x 1/64" | 16R – Quick-Reading 32nds, 64ths, Aircraft Quick-Reading 50ths and 100ths | |

12" Semi-Flexible Steel Rules with Inch Graduations

| Cat. No. | EDP | Length | Width x Thickness | Graduations | Feature Remarks |
|------------|-------|--------|-------------------|---|-----------------|
| C303SR-12 | 51336 | 12" | 1 x 1/50" | 3R – Quick-Reading 10ths, Aircraft Quick-Reading 50ths, 32nds and 64ths | |
| C304SRE-12 | 51344 | 12" | 1 x 1/50" | 4R – 8ths, 16ths, Quick-Reading 32nds and 64ths; End Graduations in 32nds Both Ends, One Side | End Graduations |

12" Spring-Tempered Steel Rules with Inch Graduations

| Cat. No. | EDP | Length | Width x Thickness | Graduations | Feature Remarks |
|----------------|-------|--------|-------------------|--|--|
| C601-12 | 52640 | 12" | 1 x 3/64" | 1 – 10ths, 20ths, 50ths, 100ths; 12ths, 24ths, 48ths; 16ths, 32nds, 64ths; 14ths, 28ths | See Note on Previous Page ** |
| 604R-12 | 52647 | 12" | 1 x 3/64" | 4R – 8ths, 16ths, Quick-Reading 32nds and 64ths | Regular Steel Finish |
| C604R-12 | 52679 | 12" | 1 x 3/64" | 4R – 8ths, 16ths, Quick-Reading 32nds and 64ths | With Standard Letter of Certification† |
| C604R-12 W/SLC | 66885 | 12" | 1 x 3/64" | 4R – 8ths, 16ths, Quick-Reading 32nds and 64ths | |
| C604RE-12 | 52661 | 12" | 1 x 3/64" | 4R – 8ths, 16ths, Quick-Reading 32nds and 64ths; End Graduations in 32nds Both Ends, One Side | End Graduations |
| H604R-12 | 52669 | 12" | 1 x 3/64" | 4R – 8ths, 16ths, Quick-Reading 32nds and 64ths | Regular Steel Finish; With Reversible Hook |
| CH604R-12 | 52674 | 12" | 1 x 3/64" | 4R – 8ths, 16ths, Quick-Reading 32nds and 64ths | With Reversible Hook |
| DH604R-12 | 52664 | 12" | 1 x 3/64" | 4R – 8ths, 16ths, Quick-Reading 32nds and 64ths | Regular Steel Finish with Adjustable Double Hook |
| CD604R-12 | 52666 | 12" | 1 x 3/64" | 4R – 8ths, 16ths, Quick-Reading 32nds and 64ths | With Adjustable Double Hook |
| C606R-12 | 52653 | 12" | 1 x 3/64" | 6R – Both Sides – Aircraft Quick-Reading 50ths (.02) Both Edges, One Side; Quick-Reading 10ths (.10) Both Edges, Opposite Side | |
| C607R-12 | 52689 | 12" | 1 x 3/64" | 7R – 16ths, Quick-Reading 32nds, 64ths, Aircraft Quick-Reading 100ths | |
| C616R-12 | 52702 | 12" | 1 x 3/64" | 16R – Quick-Reading 32nds, 64ths, Aircraft Quick-Reading 50ths, 100ths | |
| 1604R-12 | 53211 | 12" | 1 x 3/64" | 4R – 8ths, 16ths, Quick-Reading 32nds and 64ths | Stainless Steel |
| 610N-12* | 52695 | 12" | 3/16 x 3/64" | 10 – 32nds One Side and 64ths on Reverse Side | Regular Steel Finish; Narrow Rule |
| C610N-12* | 67103 | 12" | 3/16 x 3/64" | 10 – 32nds One Side and 64ths on Reverse Side | Narrow Rule |
| H610N-12* | 52698 | 12" | 3/16 x 3/64" | 10 – 32nds One Side and 64ths on Reverse Side | Regular Steel Finish; Narrow Rule with Hook |

† Includes redemption card for Standard Letter of Certification (SLC).

* Indicates rules with single row of inch figures (all rules under 1" width). Rules without asterisk have double row of inch figures, and each edge represents the bottom edge reading left to right (rules 1" and wider).

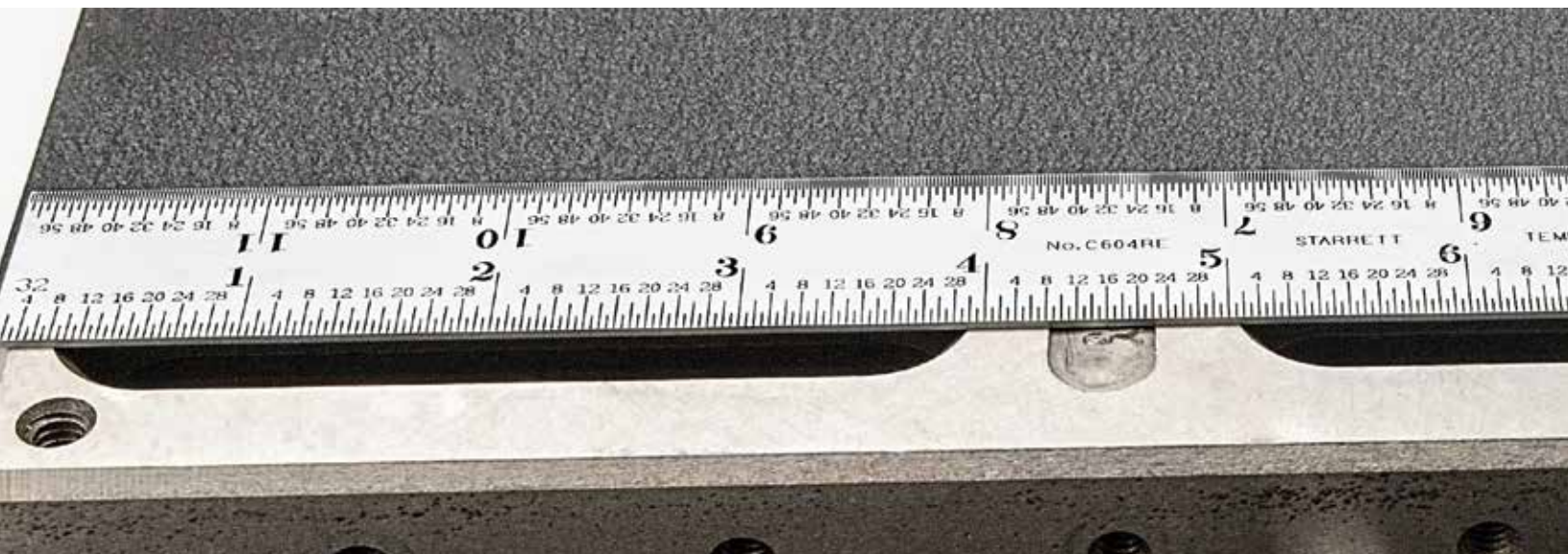

STEEL RULES

STEEL RULES WITH INCH GRADUATIONS

1-144"

All rules furnished with Starrett satin chrome finish, except where noted. Additional sizes and variations available by special order.

| 18" Full-Flexible Steel Rules with Inch Graduations | | | | | |
|---|-------|--------|-------------------|---|--|
| Cat. No. | EDP | Length | Width x Thickness | Graduations | Feature Remarks |
| C305R-18* | 51349 | 18" | 3/4 x 1/50" | 5R – Quick-Reading 10ths, Aircraft Quick-Reading 100ths, 32nds and 64ths | |
| C316R-18* | 51376 | 18" | 3/4 x 1/50" | 16R – Quick-Reading 32nds, 64ths, Aircraft Quick-Reading 50ths and 100ths | |
| 18" Spring-Tempered Steel Rules with Inch Graduations | | | | | |
| Cat. No. | EDP | Length | Width x Thickness | Graduations | Feature Remarks |
| C604R-18 | 52680 | | | | |
| C604R-18 W/SLC | 66886 | 18" | 1-1/8 x 3/64" | 4R – 8ths, 16ths, Quick-Reading 32nds and 64ths | With Standard Letter of Certification† |
| CH604R-18 | 52675 | | | | With Hook |
| 24" Full-Flexible Steel Rules with Inch Graduations | | | | | |
| Cat. No. | EDP | Length | Width x Thickness | Graduations | Feature Remarks |
| C304R-24 | 56645 | 24" | 3/4 x 1/50" | 4R – 8ths, 16ths, Quick-Reading 32nds and 64ths | |
| C305R-24* | 51350 | 24" | 3/4 x 1/50" | 5R – Quick-Reading 10ths, Aircraft Quick-Reading 100ths, 32nds and 64ths | |
| C316R-24* | 51377 | 24" | 3/4 x 1/50" | 16R – Quick-Reading 32nds, 64ths, Aircraft Quick-Reading 50ths and 100ths | |
| 24" Semi-Flexible Steel Rules with Inch Graduations | | | | | |
| Cat. No. | EDP | Length | Width x Thickness | Graduations | Feature Remarks |
| C303SR-24 | 51338 | 24" | 1" x 1/50" | 3R – Quick-Reading 10ths, Aircraft Quick-Reading 50ths, 32nds and 64ths | |
| 24" Spring-Tempered Steel Rules with Inch Graduations | | | | | |
| Cat. No. | EDP | Length | Width x Thickness | Graduations | Feature Remarks |
| C604R-24 | 52681 | | | | |
| C604R-24 W/SLC | 66887 | 24" | 1-1/4 x 3/64" | 4R – 8ths, 16ths, Quick-Reading 32nds and 64ths | With Standard Letter of Certification† |
| CH604R-24 | 52676 | | | | With Hook |
| C607R-24 | 52691 | 24" | 1-1/4 x 3/64" | 7R – 16ths, Quick-Reading 32nds, 64ths, Aircraft Quick-Reading 100ths | |
| 24" Heavy Spring-Tempered Steel Rules with Inch Graduations | | | | | |
| Cat. No. | EDP | Length | Width x Thickness | Graduations | Feature Remarks |
| C404R-24 | 51484 | | | | |
| CH404R-24 | 51494 | 24" | 1-1/4 x 1/10" | 4R – 8ths, 16ths, Quick-Reading 32nds and 64ths | With Hook |
| C416R-24 | 51509 | | | | |
| CH416R-24 | 51519 | 24" | 1-1/4 x 1/10" | 16R – Quick-Reading 32nds, 64ths, Aircraft Quick-Reading 50ths and 100ths | With Hook |

All C404R and C416R Rules furnished with hole in end for hanging.

† Includes redemption card for Standard Letter of Certification (SLC).

* Indicates rules with single row of inch figures (all rules under 1" width). Rules without asterisk have double row of inch figures, and each edge represents the bottom edge reading left to right (rules 1" and wider).

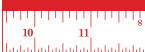

PRECISION RULES

STEEL RULES WITH INCH GRADUATIONS

1-144"

All rules furnished with Starrett satin chrome finish, except where noted. Additional sizes and variations available by special order.

36" Spring-Tempered Steel Rules with Inch Graduations

| Cat. No. | EDP | Length | Width x Thickness | Graduations | Feature Remarks |
|-----------|-------|--------|-------------------|---|-----------------|
| C604R-36 | 52682 | 36" | 1-1/4 x 3/64" | 4R – 8ths, 16ths, Quick-Reading 32nds and 64ths | With Hook |
| CH604R-36 | 52677 | | | | |
| C607R-36 | 56436 | 36" | 1-1/4 x 3/64" | 7R – 16ths, Quick-Reading 32nds, 64ths, Aircraft Quick-Reading 100ths | |

36" Heavy Spring-Tempered Steel Rules with Inch Graduations

| Cat. No. | EDP | Length | Width x Thickness | Graduations | Feature Remarks |
|----------------|-------|--------|-------------------|---|---|
| C404R-36 | 51485 | 36" | 1-1/2 x 1/10" | 4R – 8ths, 16ths, Quick-Reading 32nds and 64ths | With Standard Letter of Certification† With Hook |
| C404R-36 W/SLC | 66888 | | | | |
| CH404R-36 | 51495 | | | | |
| C416R-36 | 51510 | 36" | 1-1/2 x 1/10" | 16R – Quick-Reading 32nds, 64ths, Aircraft Quick-Reading 50ths and 100ths | With Hook |
| CH416R-36 | 51520 | | | | |

48" Spring-Tempered Steel Rules with Inch Graduations

| Cat. No. | EDP | Length | Width x Thickness | Graduations | Feature Remarks |
|----------|-------|--------|-------------------|---|-----------------|
| C604R-48 | 52683 | 48" | 1-1/4 x 3/64" | 4R – 8ths, 16ths, Quick-Reading 32nds and 64ths | |
| C607R-48 | 56437 | | | | |
| | | 48" | 1-1/4 x 3/64" | 7R – 16ths, Quick-Reading 32nds, 64ths, Aircraft Quick-Reading 100ths | |

48-144" Heavy Spring-Tempered Steel Rules with Inch Graduations

| Cat. No. | EDP | Length | Width x Thickness | Graduations | Feature Remarks |
|----------------|-------|--------|-------------------|---|---|
| C404R-48 | 51486 | 48" | 1-1/2 x 1/10" | 4R – 8ths, 16ths, Quick-Reading 32nds and 64ths | With Standard Letter of Certification† With Hook |
| C404R-48 W/SLC | 66889 | | | | |
| CH404R-48 | 51496 | | | | |
| C416R-48 | 51511 | 48" | 1-1/2 x 1/10" | 16R – Quick-Reading 32nds, 64ths, Aircraft Quick-Reading 50ths and 100ths | With Hook |
| CH416R-48 | 51521 | | | | |
| C404R-72 | 51488 | 72" | 1-1/2 x 1/10" | 4R – 8ths, 16ths, Quick-Reading 32nds and 64ths | With Hook |
| CH404R-72 | 51498 | | | | |
| C416R-72 | 51513 | 72" | 1-1/2 x 1/10" | 16R – Quick-Reading 32nds, 64ths, Aircraft Quick-Reading 50ths and 100ths | With Hook |
| CH416R-72 | 51523 | | | | |
| C404R-96 | 56191 | 96" | 1-1/2 x 1/10" | 4R – 8ths, 16ths, Quick-Reading 32nds and 64ths | With Hook |
| CH404R-96 | 56474 | | | | |
| C416R-96 | 56197 | 96" | 1-1/2 x 1/10" | 16R – Quick-Reading 32nds, 64ths, Aircraft Quick-Reading 50ths and 100ths | With Hook |
| CH416R-96 | 56477 | | | | |
| C404R-120 | 56192 | 120" | 1-1/2 x 1/10" | 4R – 8ths, 16ths, Quick-Reading 32nds and 64ths | With Hook |
| CH404R-120 | 56475 | | | | |
| C416R-120 | 56198 | 120" | 1-1/2 x 1/10" | 16R – Quick-Reading 32nds, 64ths, Aircraft Quick-Reading 50ths and 100ths | With Hook |
| CH416R-120 | 56478 | | | | |
| C404R-144 | 56193 | 144" | 1-1/2 x 1/10" | 4R – 8ths, 16ths, Quick-Reading 32nds and 64ths | With Hook |
| CH404R-144 | 56476 | | | | |
| C416R-144 | 56199 | 144" | 1-1/2 x 1/10" | 16R – Quick-Reading 32nds, 64ths, Aircraft Quick-Reading 50ths and 100ths | With Hook |
| CH416R-144 | 56479 | | | | |

All C404R and C416R Rules furnished with hole in end for hanging.

† Includes redemption card for Standard Letter of Certification (SLC).



PRECISION RULES

MILLIMETER GRADUATION STYLES

30

First Edge: None

Second Edge: 1/2mm

Fourth Edge: 1/2mm

Third Edge: mm



35

Reads both left-to-right and right-to-left. A Starrett original feature.

First Edge: mm

Second Edge: 1/2mm

Fourth Edge: mm

Third Edge: 1/2mm

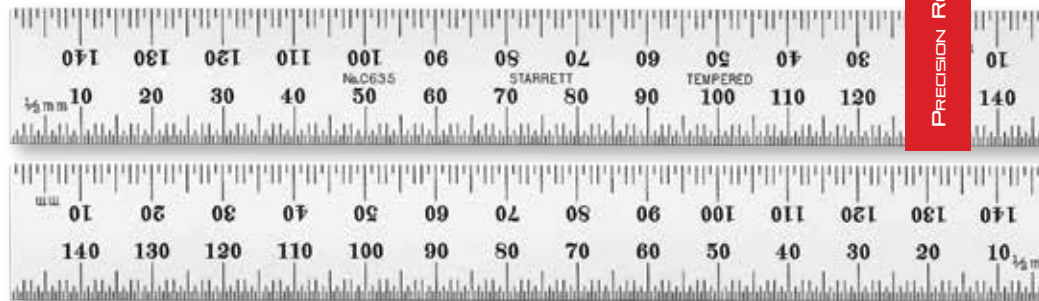

35E

First Edge: mm

End Graduations: mm

Second Edge: 1/2mm

Fourth Edge: mm

Third Edge: 1/2mm

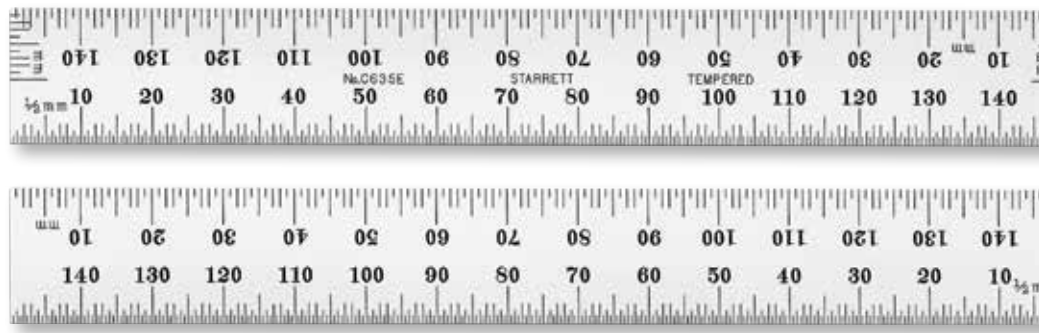

37

First Edge: mm

Second Edge: 1/2mm

Fourth Edge: 1/2mm

Third Edge: mm

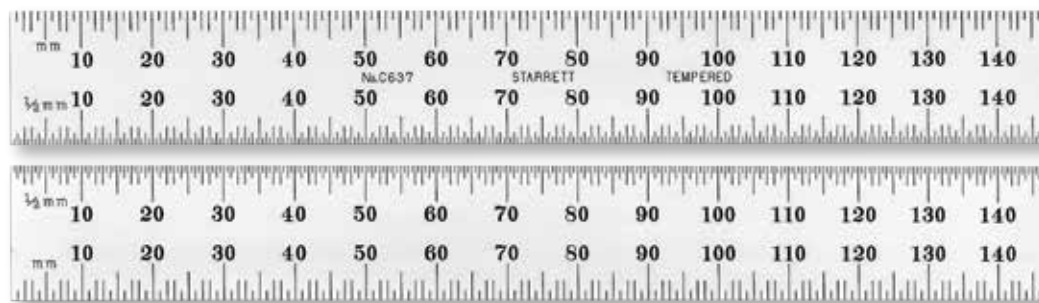

37E

First Edge: mm

End Graduations: mm

Second Edge: 1/2mm

Fourth Edge: 1/2mm

Third Edge: mm

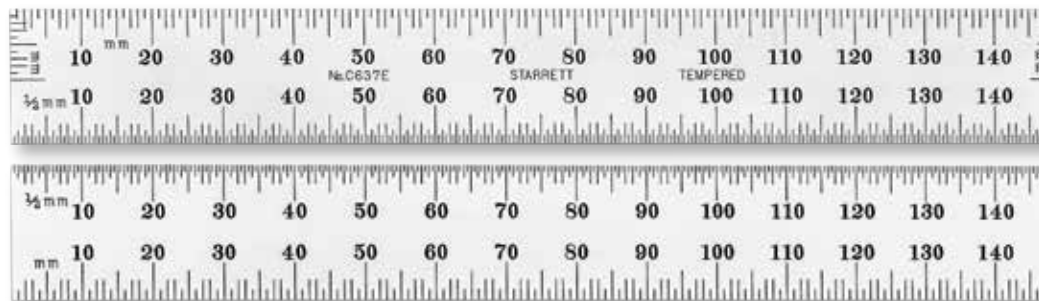

NOTE: All rules under 25mm in width have single row of millimeter figures. Rules 25mm and wider have double row of millimeter figures, and each edge represents the bottom edge reading left to right.

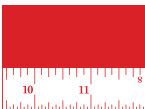

STEEL RULES

STEEL RULES WITH MILLIMETER GRADUATIONS

150-1800MM

All rules furnished with Starrett satin chrome finish, except where noted. Additional sizes and variations available by special order.

RULES INCLUDE:

- Full-Flexible
- Semi-Flexible
- Spring-Tempered
- Heavy Spring-Tempered

Catalog Number Legend

| Prefixes | |
|----------|---------------------|
| C | Satin Chrome Finish |
| Suffixes | |
| E | End Graduations |
| N | Narrow-Type Rule |
| S | Semi-Flexible |

150mm Full-Flexible Steel Rules with Millimeter Graduations

| Cat. No. | EDP | Length | Width x Thickness | Graduations | Feature Remarks |
|-----------------|-------|--------|-------------------|--|---|
| C330-150* | 51329 | 150mm | 12.7 x 0.4mm | 30 – 1/2mm One Side; mm and 1/2mm on Reverse | |
| C330-150 W/SLC* | 66882 | | | | With Standard Letter of Certification** |

150mm Spring-Tempered Steel Rules with Millimeter Graduations

| Cat. No. | EDP | Length | Width x Thickness | Graduations | Feature Remarks |
|----------------|-------|--------|-------------------|---|---|
| C635-150 | 52630 | 150mm | 19 x 1.2mm | 35 – mm and 1/2mm Both Sides | |
| C635-150 W/SLC | 66893 | | | | With Standard Letter of Certification** |
| C635E-150 | 55968 | 150mm | 19 x 1.2mm | 35E – mm and 1/2mm Both Sides; mm on Both Ends One Side | End Graduations |
| 635N-150 | 70164 | 150mm | 4.8 x 1.2mm | 35 – mm One Edge and 1/2mm One Edge on Reverse | Narrow Rule, Regular Steel Finish |
| C637-150 | 56049 | 150mm | 19 x 1.2mm | 37 – mm and 1/2mm Both Sides | |
| C637E-150 | 55969 | 150mm | 19 x 1.2mm | 37E – mm and 1/2mm Both Sides; mm on Both Ends One Side | End Graduations |

300mm Full-Flexible Steel Rules with Millimeter Graduations

| Cat. No. | EDP | Length | Width x Thickness | Graduations | Feature Remarks |
|-----------------|-------|--------|-------------------|--|---|
| C330-300* | 51330 | 300mm | 12.7 x 0.4mm | 30 – 1/2mm One Side; mm and 1/2mm on Reverse | |
| C330-300 W/SLC* | 66883 | | | | With Standard Letter of Certification** |

300mm Semi-Flexible Steel Rules with Millimeter Graduations

| Cat. No. | EDP | Length | Width x Thickness | Graduations | Feature Remarks |
|-----------|-------|--------|-------------------|------------------------------|-----------------|
| C335S-300 | 56048 | 300mm | 25.4 x 0.5mm | 35 – mm and 1/2mm Both Sides | |

300mm Spring-Tempered Steel Rules with Millimeter Graduations

| Cat. No. | EDP | Length | Width x Thickness | Graduations | Feature Remarks |
|----------------|-------|--------|-------------------|------------------------------|---|
| C635-300 | 52631 | 300mm | 25.4 x 1.2mm | 35 – mm and 1/2mm Both Sides | |
| C635-300 W/SLC | 66894 | | | | With Standard Letter of Certification** |

500mm Spring-Tempered Steel Rules with Millimeter Graduations

| Cat. No. | EDP | Length | Width x Thickness | Graduations | Feature Remarks |
|----------|-------|--------|-------------------|------------------------------|-----------------|
| C635-500 | 52632 | 500mm | 29 x 1.2mm | 35 – mm and 1/2mm Both Sides | |

1000mm Spring-Tempered Steel Rules with Millimeter Graduations

| Cat. No. | EDP | Length | Width x Thickness | Graduations | Feature Remarks |
|-----------|-------|--------|-------------------|------------------------------|-----------------|
| C635-1000 | 52633 | 1000mm | 32 x 1.2mm | 35 – mm and 1/2mm Both Sides | |

1800mm Heavy Spring-Tempered Steel Rules with Millimeter Graduations

| Cat. No. | EDP | Length | Width x Thickness | Graduations | Feature Remarks |
|-------------|-------|--------|-------------------|------------------------------|-----------------|
| C635-1800MM | 64299 | 1800mm | 38 x 2.5mm | 35 – mm and 1/2mm Both Sides | |

** Includes redemption card for Standard Letter of Certification (SLC).

* Indicates rules with single row of millimeter figures (all rules under 25mm width). Rules without asterisk have double row of millimeter figures, and each edge represents the bottom edge reading left to right (rules 25mm and wider).



PRECISION RULES

MILLIMETER AND INCH GRADUATION STYLES

31

- First Edge: 32nds
- Second Edge: 64ths
- Fourth Edge: 1/2mm
- Third Edge: mm

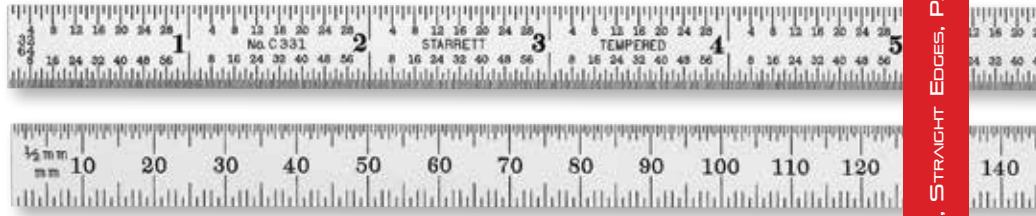

34

- First Edge: 10ths
- Second Edge: 50ths
- Fourth Edge: mm
- Third Edge: 1/2mm

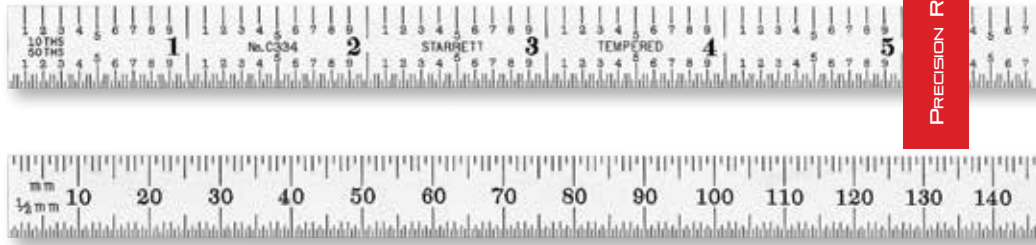

36*

- First Edge: 32nds
- Second Edge: 1/2mm
- Fourth Edge: mm
- Third Edge: 64ths

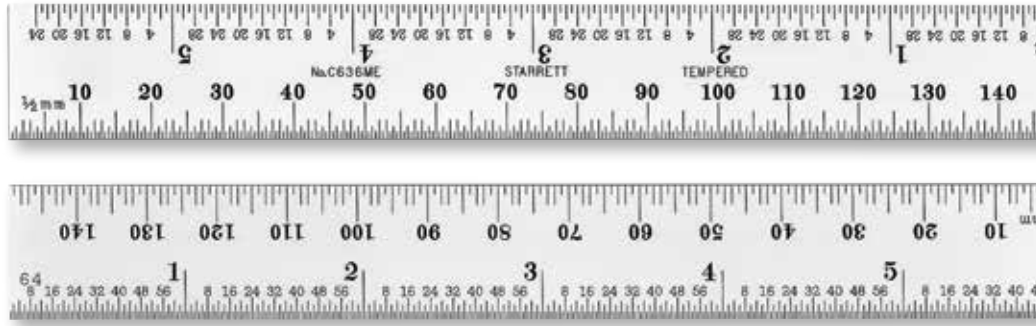

CATALOG C636EM-6

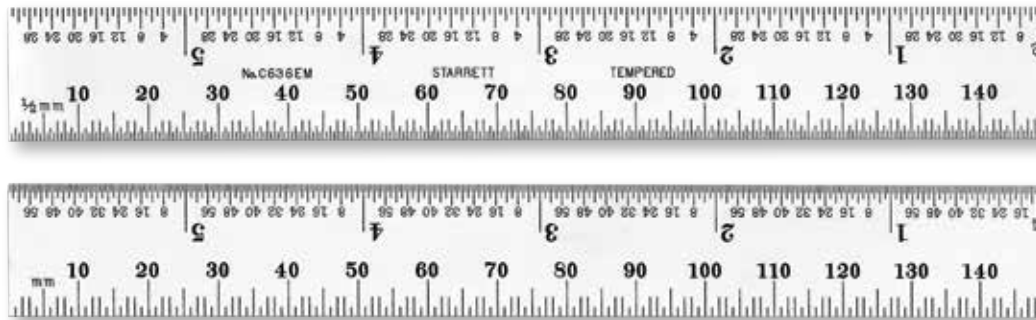

31, 34, AND 36* STYLES ARE GRADUATED AS FOLLOWS:

- 150mm end-to-end on mm edges and to 5-3/4" with a blank end on the inch edges
- 300mm end-to-end on mm edges and to 11-3/4" with a blank end on the inch edges
- 500mm end-to-end on mm edges and to 19-1/2" with a blank end on the inch edges
- 1000mm end-to-end on mm edges and to 39-1/4" with a blank end on the inch edges

CATALOG C636EM-6 IS GRADUATED AS FOLLOWS:

- 6" end-to-end on the inch edges and to 150mm with a blank end on the mm edges

NOTE: * Millimeter/Inch scale with emphasis on millimeter. Overall length is 150mm (5.905").
Inch graduations stop at 5-3/4" to avoid confusion.

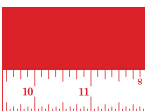

STEEL RULES

STEEL RULES WITH MILLIMETER AND INCH GRADUATIONS

150MM-1000MM

All rules are full millimeter lengths, except where noted. Additional sizes and variations available by special order.

RULES INCLUDE:

- Full-Flexible
- Spring-Tempered

| Key to Starrett Rule Numbering System | |
|---------------------------------------|---------------------|
| Prefixes | |
| C | Satin Chrome Finish |
| Suffixes | |
| EM | English/ Metric |
| ME | Metric/English |

150mm - 5-3/4" Full-Flexible Steel Rules with Millimeter and Inch Graduations

| Cat. No. | EDP | Length | Width x Thickness | Graduations | Feature Remarks |
|----------|-------|--------|-------------------|--|-----------------|
| C331-150 | 51331 | 150mm | 12 x 0.4mm | 31 – 32nds and 64ths on One Side; mm and 1/2mm on Reverse. All Four Edges Graduated from Same End | |
| C334-150 | 56262 | 5-3/4" | 12 x 0.4mm | 34 – mm and 1/2mm on One Side; Quick-Reading 10ths (.10) and Aircraft Quick-Reading 50ths (.02) on Reverse | |

150mm - 6" Spring-Tempered Steel Rules with Millimeter and Inch Graduations

| Cat. No. | EDP | Length | Width x Thickness | Graduations | Feature Remarks |
|------------------|-------|----------------|-------------------|---|--|
| C636ME-150 | 52634 | 150mm (5-3/4") | 19 x 1.2mm | 36 – 32nds and 1/2mm on One Side; 64ths and mm on Reverse | |
| C636ME-150 W/SLC | 66890 | | | | With Standard Letter of Certification* |
| C636EM-6 | 57064 | 150mm 6" | 19 x 1.2mm | 36 – 32nds and 1/2mm on One Side; 64ths and mm on Reverse | Full 6" with Millimeter Reading to 150mm; plus a Blank End |

300mm - 11-3/4" Full-Flexible Steel Rules with Millimeter and Inch Graduations

| Cat. No. | EDP | Length | Width x Thickness | Graduations | Feature Remarks |
|----------|-------|---------|-------------------|---|-----------------|
| C331-300 | 51332 | 300mm | 12.7 x 0.4mm | 31 – 32nds and 64ths on One Side; mm and 1/2mm on Reverse. All Four Edges Graduated from Same End | |
| C334-300 | 56696 | 11-3/4" | 12.7 x 0.4mm | 34 – mm and 1/2mm One Side; Quick-Reading 10ths (.10) and Aircraft Quick-Reading 50ths (.02) on Reverse | |

300mm - 11-3/4" Spring-Tempered Steel Rules with Millimeter and Inch Graduations

| Cat. No. | EDP | Length | Width x Thickness | Graduations | Feature Remarks |
|----------------|-------|-----------------|-------------------|---|--|
| C636-300 | 52635 | 300mm (11-3/4") | 25.4 x 1.2mm | 36 – 32nds and 1/2mm on One Side; 64ths and mm on Reverse | |
| C636-300 W/SLC | 66891 | | | | With Standard Letter of Certification* |

500mm - 19-1/2" Full-Flexible Steel Rules with Millimeter and Inch Graduations

| Cat. No. | EDP | Length | Width x Thickness | Graduations | Feature Remarks |
|----------|-------|-----------------|-------------------|--|-----------------|
| C334-500 | 56697 | 500mm (19-1/2") | 19 x 0.5mm | 34 – mm and 1/2mm on One Side; Quick-Reading 10ths (.10) and Aircraft Quick-Reading 50ths (.02) on Reverse | |

500mm - 19-1/2" Spring Tempered Steel Rules with Millimeter and Inch Graduations

| Cat. No. | EDP | Length | Width x Thickness | Graduations | Feature Remarks |
|-------------|-------|-----------------|-------------------|--|-----------------|
| C636MEC-500 | 73320 | 500mm (19-1/2") | 32 x 1.1mm | Zero scale on 32nds and 1/2mm Side; Incremental Scale on 64ths and mm Side | |

500mm - 19-1/2" Spring-Tempered Steel Rules with Millimeter and Inch Graduations

| Cat. No. | EDP | Length | Width x Thickness | Graduations | Feature Remarks |
|----------|-------|-----------------|-------------------|---|-----------------|
| C636-500 | 52636 | 500mm (19-1/2") | 29 x 1.2mm | 36 – 32nds and 1/2mm on One Side; 64ths and mm on Reverse | |

1000mm - 39-1/4" Spring-Tempered Steel Rules with Millimeter and Inch Graduations

| Cat. No. | EDP | Length | Width x Thickness | Graduations | Feature Remarks |
|-----------------|-------|------------------|-------------------|---|--|
| C636-1000 | 52637 | 1000mm (39-1/4") | 32 x 1.2mm | 36 – 32nds and 1/2mm on One Side; 64ths and mm on Reverse | |
| C636-1000 W/SLC | 66892 | | | | With Standard Letter of Certification* |

* Includes redemption card for Standard Letter of Certification (SLC).

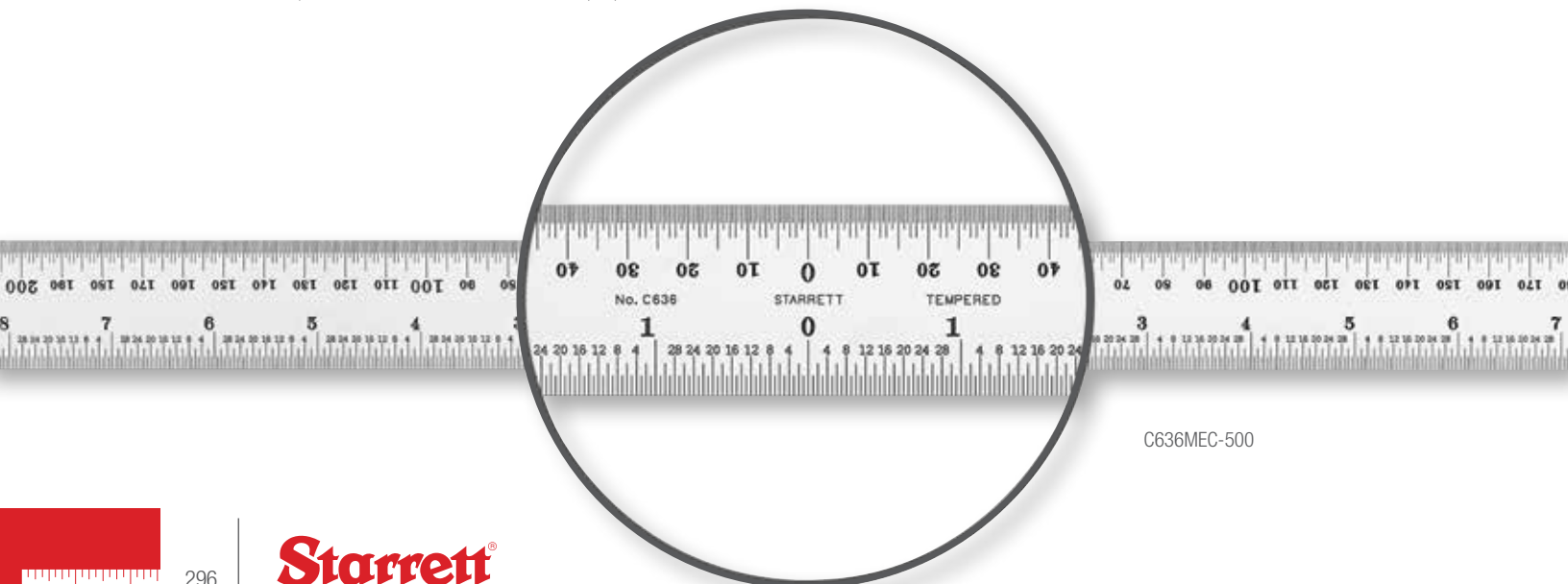

C636MEC-500

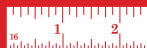

STEEL RULES

STEEL RULES WITH SHRINK GRADUATIONS

12", 24"

These spring-tempered, satin chrome finished shrink rules are for laying out wood and metal patterns and core boxes for casting metals. Graduated to give shrink allowances directly, they come in 12" and 24" lengths with shrinks from 1/16-3/8" per foot.

The average shrinkage figures are for metals cast with uniform sections under normal conditions (see table). When using, be sure that the size and shape of castings are considered, since thick castings have less shrink and thin castings more shrink than the figures shown.

NOTE: Also see 62 Rule Holder. A very useful tool for patternmakers.

| Average Shrinkage of Castings (Inches per Foot) | |
|---|-------|
| Cast Iron | 1/8" |
| Malleable Iron | 1/8" |
| Steel | 1/4" |
| Brass | 3/16" |
| Copper | 3/16" |
| Aluminum | 3/16" |
| Lead | 5/16" |
| Zinc | 5/16" |
| Britannia | 1/32" |
| Tin Alloys | 1/12" |

| Steel Rules with Shrink Graduations | | | | | |
|-------------------------------------|-------|--------|-------------------|-----------------|--|
| Cat. No. | EDP | Length | Width x Thickness | Shrink Per Foot | Graduation |
| C374-12 | 51430 | 12" | 1 x 3/64" | 1/10" | 4R – 8ths, 16ths, Quick-Reading 32nds, 64ths |
| C370-12 | 51428 | 12" | 1 x 3/64" | 1/8" | 4R – 8ths, 16ths, Quick-Reading 32nds, 64ths |
| C389-12 | 51473 | 12" | 1 x 3/64" | 5/32" | 4R – 8ths, 16ths, Quick-Reading 32nds, 64ths |
| C100F-12 | 50458 | 12" | 1 x 3/64" | 3/16" | 6R – Aircraft Quick-Reading 50ths (.02) Both Edges One Side; Quick-Reading 10ths (.10); Both Edges Opposite Side |
| C375-12 | 51432 | 12" | 1 x 3/64" | 3/16" | 4R – 8ths, 16ths, Quick-Reading 32nds, 64ths |
| C376-12 | 51434 | | | 7/32" | |
| C377-12 | 51435 | | | 1/4" | |
| C378-12 | 51437 | | | 9/32" | |
| C368-12 | 51424 | | | 5/16" | |
| C374-24 | 51431 | 24" | 1-1/4 x 3/64" | 1/10" | 4R – 8ths, 16ths, Quick-Reading 32nds, 64ths |
| C370-24 | 51429 | | | 1/8" | |
| C389-24 | 51474 | | | 5/32" | |
| C100F-24 | 50459 | 24" | 1-1/4 x 3/64" | 3/16" | 6R – Aircraft Quick-Reading 50ths (.02) Both Edges One Side; Quick-Reading 10ths (.10); Both Edges Opposite Side |
| C375-24 | 51433 | 24" | 1-1/4 x 3/64" | 3/16" | 4R – 8ths, 16ths, Quick-Reading 32nds, 64ths |
| C377-24 | 51436 | | | 1/4" | |
| C368-24 | 51425 | | | 5/16" | |

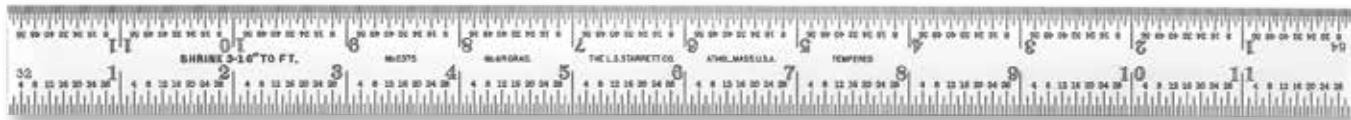

C375-12

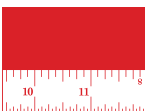

STEEL RULES

C622R-6 STEEL RULE WITH DECIMAL EQUIVALENTS

6"

One side of this handy rule has accurate, photo-engraved, distinctive graduations in both Quick-Reading 32nds and 64ths. The reverse side has a legible table of fractions and decimal equivalents. Made of finest spring-tempered steel with no-glare satin chrome finish.

6" Steel Rule with Decimal Equivalents

| Cat. No. | EDP | Width x Thickness | Graduation |
|----------|-------|-------------------|--|
| C622R-6 | 56660 | 3/4 x 3/64" | 10R – Quick-Reading 32nds and 64ths One Side and Decimal Equivalents on Reverse Side |



| DECIMAL EQUIVALENTS | |
|---------------------|-------|
| 1/64 | .0156 |
| 2/64 | .0312 |
| 3/64 | .0469 |
| 4/64 | .0625 |
| 5/64 | .0781 |
| 6/64 | .0938 |
| 7/64 | 1.094 |
| 8/64 | 1.190 |
| 9/64 | 1.286 |
| 10/64 | 1.383 |
| 11/64 | 1.479 |
| 12/64 | 1.576 |
| 13/64 | 1.673 |
| 14/64 | 1.769 |
| 15/64 | 1.866 |
| 16/64 | 1.963 |
| 17/64 | 2.059 |
| 18/64 | 2.156 |
| 19/64 | 2.253 |
| 20/64 | 2.350 |
| 21/64 | 2.446 |
| 22/64 | 2.543 |
| 23/64 | 2.640 |
| 24/64 | 2.737 |
| 25/64 | 2.834 |
| 26/64 | 2.930 |
| 27/64 | 3.027 |
| 28/64 | 3.124 |
| 29/64 | 3.221 |
| 30/64 | 3.318 |
| 31/64 | 3.414 |
| 32/64 | 3.511 |
| 33/64 | 3.608 |
| 34/64 | 3.705 |
| 35/64 | 3.802 |
| 36/64 | 3.898 |
| 37/64 | 3.995 |
| 38/64 | 4.092 |
| 39/64 | 4.189 |
| 40/64 | 4.286 |
| 41/64 | 4.383 |
| 42/64 | 4.479 |
| 43/64 | 4.576 |
| 44/64 | 4.673 |
| 45/64 | 4.770 |
| 46/64 | 4.867 |
| 47/64 | 4.964 |
| 48/64 | 5.060 |
| 49/64 | 5.157 |
| 50/64 | 5.254 |
| 51/64 | 5.351 |
| 52/64 | 5.448 |
| 53/64 | 5.545 |
| 54/64 | 5.641 |
| 55/64 | 5.738 |
| 56/64 | 5.835 |
| 57/64 | 5.932 |
| 58/64 | 6.029 |
| 59/64 | 6.126 |
| 60/64 | 6.222 |
| 61/64 | 6.319 |
| 62/64 | 6.416 |
| 63/64 | 6.513 |
| 64/64 | 6.610 |

C622R-6

C623R-6 STEEL RULE WITH LETTER AND NUMBER DRILL SIZES

6"

This practical shop rule has accurate, photo-engraved graduations in 32nds and 64ths with Quick-Reading figures on one side. The reverse side has letter sizes of drills from A to Z with corresponding diameters in thousandths and also number sizes from 1 to 80 with diameters in thousandths. Made of fine spring-tempered steel with no-glare satin chrome finish.

6" Steel Rule with Letter and Number Drill Sizes

| Cat. No. | EDP | Width x Thickness | Graduation |
|----------|-------|-------------------|--|
| C623R-6 | 56661 | 3/4 x 3/64" | 10R – Quick-Reading 32nds and 64ths One Side and Letter and Number Drill Sizes on Reverse Side |



| DRILL SIZE TABLE | |
|------------------|-------|
| NUMBER SIZES | |
| 1 | .228 |
| 2 | .250 |
| 3 | .271 |
| 4 | .291 |
| 5 | .312 |
| 6 | .332 |
| 7 | .353 |
| 8 | .375 |
| 9 | .396 |
| 10 | .417 |
| 11 | .437 |
| 12 | .458 |
| 13 | .479 |
| 14 | .500 |
| 15 | .520 |
| 16 | .541 |
| 17 | .562 |
| 18 | .583 |
| 19 | .604 |
| 20 | .625 |
| 21 | .646 |
| 22 | .667 |
| 23 | .688 |
| 24 | .709 |
| 25 | .730 |
| 26 | .751 |
| 27 | .772 |
| 28 | .793 |
| 29 | .814 |
| 30 | .835 |
| 31 | .856 |
| 32 | .877 |
| 33 | .898 |
| 34 | .919 |
| 35 | .940 |
| 36 | .961 |
| 37 | .982 |
| 38 | 1.003 |
| 39 | 1.024 |
| 40 | 1.045 |
| 41 | 1.066 |
| 42 | 1.087 |
| 43 | 1.108 |
| 44 | 1.129 |
| 45 | 1.150 |
| 46 | 1.171 |
| 47 | 1.192 |
| 48 | 1.213 |
| 49 | 1.234 |
| 50 | 1.255 |
| 51 | 1.276 |
| 52 | 1.297 |
| 53 | 1.318 |
| 54 | 1.339 |
| 55 | 1.360 |
| 56 | 1.381 |
| 57 | 1.402 |
| 58 | 1.423 |
| 59 | 1.444 |
| 60 | 1.465 |
| 61 | 1.486 |
| 62 | 1.507 |
| 63 | 1.528 |
| 64 | 1.549 |
| 65 | 1.570 |
| 66 | 1.591 |
| 67 | 1.612 |
| 68 | 1.633 |
| 69 | 1.654 |
| 70 | 1.675 |
| 71 | 1.696 |
| 72 | 1.717 |
| 73 | 1.738 |
| 74 | 1.759 |
| 75 | 1.780 |
| 76 | 1.801 |
| 77 | 1.822 |
| 78 | 1.843 |
| 79 | 1.864 |
| 80 | 1.885 |
| LETTER SIZES | |
| A | .234 |
| B | .238 |
| C | .242 |
| D | .246 |
| E | .250 |
| F | .257 |
| G | .261 |
| H | .266 |
| I | .272 |
| J | .277 |
| K | .281 |
| L | .290 |
| M | .295 |

C623R-6

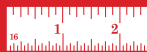

STEEL RULES

414 STEEL GENERAL UTILITY RULES – ENGLISH PATTERN

12", 24"

These tempered steel rules are designed to meet the general-utility measuring needs of schools and shops, wood-workers, tinsmiths, metalworkers, bench-work, etc. Photo-engraved graduations are heavier than conventional machine-divided rules and easy to read. The two edges on both sides are graduated with the upper edges in 8ths and the lower edges in 16ths of an inch. A 1/4" hang-hole is on one end.

| 414 Steel General Utility Rules – English Pattern | | | | |
|---|-------|--------|-------------------|------------------------------------|
| Cat. No. | EDP | Length | Width x Thickness | Graduation |
| 414-1 | 51499 | 12" | 1-1/4 x 1/16" | 8ths, 16ths of an Inch, Both Sides |
| 414-2 | 51500 | 24" | | |



414-1

471 STEEL FOLDING RULE WITH CIRCUMFERENCE MEASUREMENT

24"

Tinsmiths and other mechanics appreciate this rule because it measures diameters up to 24" as well as the equivalent circumference measurement in direct-reading circumference inches, up to 75". Entirely eliminates the need for circumference calculations. Made of fine, spring-tempered steel and jointed at the center with two 12" folds. Photo-engraved graduations.

| 24" Steel Folding-Rule with Circumference Measurement | | | |
|---|-------|-------------------|--|
| Cat. No. | EDP | Width x Thickness | Graduation |
| 471 | 52483 | 3/4" x 1/32" | 8ths and Circumference 8ths on One Side; 16ths on Reverse Side |



471



CLAMPS

KEY SEAT CLAMPS

These key seat clamps convert steel rules, combination square blades and straight edges into key seat rules for laying out keyways and scribing parallel lines on round work. They can be easily attached or removed. Made of steel, case hardened, and accurately ground, they are 1" long x 7/16" wide (25 x 11mm) and have a 7/64" (2.8mm) slot width. Available in pairs only.

Key Seat Clamps

| Cat. No. | EDP | Description |
|----------|-------|-------------------------|
| 298 | 51327 | Pair of key seat clamps |

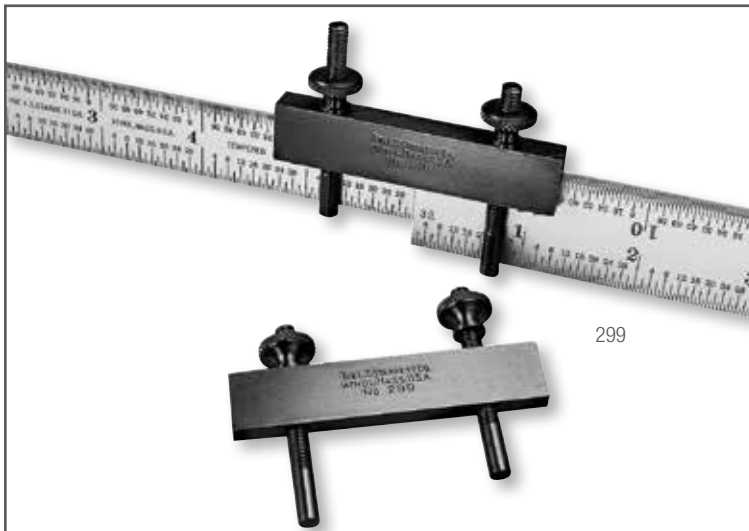
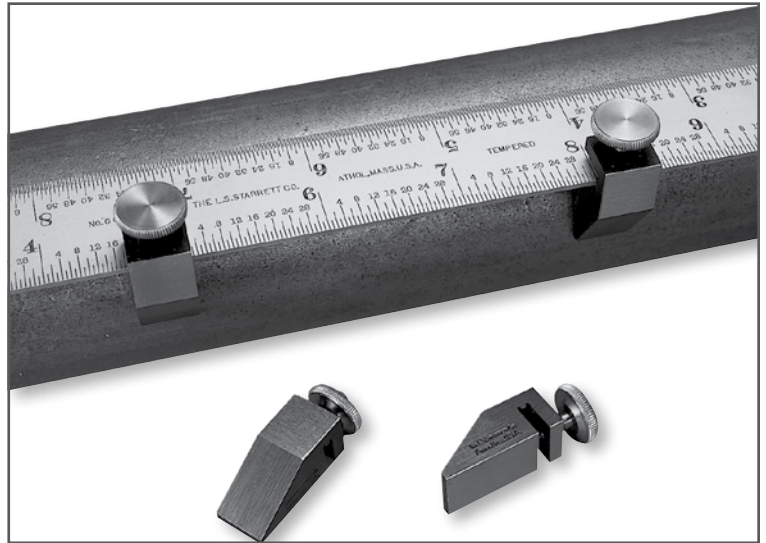

RULE CLAMP

This useful tool is for clamping two steel rules together, end to end, making one long rule for measuring longer lengths than a single rule. Since the clamp bolts have independent adjustment, the rule clamp will hold rules of the same or different widths up to 1-1/4" (32mm). This clamp is handy for mechanics whose tool chests will not hold rules over 12" (300mm) long.

Rule Clamp

| Cat. No. | EDP | Description |
|----------|-------|-------------|
| 299 | 51328 | Rule clamp |



HOLDERS

62 Rule Holder

The 62 Rule Holder is designed primarily for patternmakers, toolmakers and machinists. It will hold any rule or combination square blade from 3/4 – 1-9/16" (19-40mm) wide in an upright position for use in transferring measurements with surface gages, etc. It is also handy for use as a depth gage. A large knurled clamp nut securely locks the rule in the holder.

The base is approximately 3-1/8" long and 2-1/2" wide (80 x 60mm). There is a depression on each side for thumb and fingers for handling convenience.

| 62 Rule Holder | | |
|----------------|-------|-------------|
| Cat. No. | EDP | Description |
| 62 | 50304 | Holder only |



Transferring measurements with a Starrett Surface Gage used in conjunction with rule and rule holder



62

423 SMALL STEEL RULES WITH HOLDER

1/4, 3/8, 1/2, 3/4, 1"

This set of five small rules is extremely useful for measurements in confined or hard-to-reach locations. They are especially suitable for measuring grooves, short shoulders, recesses, keyways, and in tool and die work.

The 4" long holder is well balanced. The rules are easily inserted in the slotted end of the holder and are rigidly clamped in place by a slight turn of a knurled nut. Two slots are provided, so the rules can be held at 30° or 45°, either square in a slot or tipped to one side.

Thicknesses up to 1/16" can be clamped in either slot. Rules are made of thin, spring-tempered steel, with bright finish and highly accurate, photo-engraved graduations. Each rule is graduated in 32nds of an inch on one side and 64ths on the reverse.

| 423 Small Steel Rules with Holder | | |
|-----------------------------------|-------|---|
| Cat. No. | EDP | Description |
| S423Z | 51524 | Set of 5 rules with holder in attractive, protective case |
| 110 | 50475 | Holder Only |



S423Z

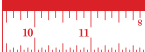

Starrett
No. 380

STEEL STRAIGHT EDGES

380 STEEL STRAIGHT EDGES

385 STEEL STRAIGHT EDGES WITH BEVEL EDGE

12-72"/300-1800MM

387 STEEL STRAIGHT EDGES WITH BEVEL AND GRADUATED EDGE

12-48"/300-1200MM

These straight edges are precision ground and nicely finished to rigid Starrett standards. They are unexcelled for drawing or scribing straight lines and checking surfaces for straightness. Their thickness and design permit them to retain shape and accuracy, but still be portable and easy to handle.

The 380 Straight Edge is not beveled or graduated. The 385 straight edge is beveled one edge, but not graduated. The 387 straight edge has one edge that is both beveled and graduated in 32nds of an inch.

The 380 and 385 Straight Edges in sizes 36" and longer are marked with arrows at two suspension points. If the straight edges are brought to the work and used on edge, they should be suspended at these two points to minimize deflection. Most jobs involve the use of straight edges in the flat position – and it is in this position that we check most stringently.



380



385-12



387-12

Steel Straight Edges

| 380 | | 385 with Bevel | | 387 with Bevel, Graduations | | Length | | Width x Thickness | |
|---------------|-------|----------------|-------|-----------------------------|-------|--------|------|-------------------|----------|
| Cat. No. | EDP | Cat. No. | EDP | Cat. No. | EDP | in | mm | in | mm |
| 380-12 | 51438 | 385-12 | 51455 | 387-12 | 51468 | 12 | 300 | 1-13/32 x 11/64 | 36 x 4.4 |
| 380-18 | 51439 | 385-18 | 51456 | 387-18 | 51469 | 18 | 450 | 1-13/32 x 11/64 | 36 x 4.4 |
| 380-24 | 51440 | 385-24 | 51457 | 387-24 | 51470 | 24 | 600 | 1-13/32 x 11/64 | 36 x 4.4 |
| 380-24 W/SLC* | 66895 | | | | | | | | |
| 380-36 | 51441 | 385-36 | 51458 | 387-36 | 51471 | 36 | 900 | 2-13/32 x 7/32 | 60 x 5.5 |
| 380-48 | 51442 | 385-48 | 51459 | 387-48 | 51472 | 48 | 1200 | 2-13/32 x 7/32 | 60 x 5.5 |
| 380-72 | 51444 | 385-72 | 51461 | | | 72 | 1800 | 3-5/32 x 9/32 | 80 x 7 |

* Includes redemption card for Standard Letter of Certification (SLC).

386 DRAFTSMEN'S STEEL STRAIGHT EDGES WITH BEVEL EDGE

12-72"/300-1800MM

These straight edges are thinner than our 385 straight edge (3/32" or 2.4mm) making them easier for draftsmen to use. Available in lengths up to 72" long. They have an attractive nickel plated finish, are beveled on one edge, and have a convenient hang-hole on one end.

386 Draftsmen's Steel Straight Edges with bevel edge

| Cat. No. | EDP | Length | | Width x Thickness | |
|----------|-------|--------|------|-------------------|----------|
| | | in | mm | in | mm |
| 386-12 | 51462 | 12 | 300 | 1-9/16 x 3/32 | 40 x 2.4 |
| 386-24 | 51463 | 24 | 600 | 1-9/16 x 3/32 | 40 x 2.4 |
| 386-36 | 51464 | 36 | 900 | 1-9/16" x 3/32 | 40 x 2.4 |
| 386-48 | 51465 | 48 | 1200 | 2-1/8 x 3/32 | 54 x 2.4 |
| 386-72 | 51467 | 72 | 1800 | 2-5/8 x 7/64 | 66 x 2.8 |



386-12

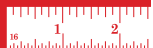

PARALLELS

384 STEEL PARALLELS

1/8" X 1" - 1/2" X 1-1/4"/3 X 25MM - 13 X 31MM

The 384 Steel Parallels are hardened and ground to close limits. They are indispensable for inspection and layout work or for various setups on drill presses, milling and grinding machines, shapers, etc. Furnished in pairs, 6" length, they are made from a special grade of tool steel, hardened and accurately ground on the four sides. In tool rooms or machine shops, several pairs of these parallels will be of great value.



S384JZ Parallel Set

384 Steel Parallels, 6" (150mm) Length

| Pairs | | Thickness | | Width | |
|----------|-------|-----------|----|-------|----|
| Cat. No. | EDP | in | mm | in | mm |
| 384A | 51445 | 1/8 | 3 | 1 | 25 |
| 384C | 51447 | 3/16 | 5 | 7/8 | 22 |
| 384E | 51449 | 1/4 | 6 | 3/4 | 19 |
| 384F | 51450 | | | 1 | 25 |
| 384G | 51451 | | | 1/2 | 13 |
| 384H | 51452 | 3/8 | 10 | 3/4 | 19 |
| 384M | 63645 | | | 3/8 | 10 |
| 384N | 63646 | 1/4 | 6 | 1/2 | 13 |
| 384P | 63647 | | | 5/8 | 16 |
| 384R | 63648 | 3/8 | 10 | 1 | 25 |
| 384S | 63649 | | | 5/8 | 16 |
| 384T | 63650 | | | 3/4 | 19 |
| 384W | 63651 | 1/2 | 13 | 1 | 25 |
| 384X | 63652 | | | 1-1/8 | 28 |
| 384Y | 63653 | | | 1-1/4 | 31 |

384 Steel Parallel Sets

| Cat. No. | EDP | Description |
|----------|-------|---|
| S384JZ | 51453 | Set of 4 Pairs – Sizes A, C, E, G – In Case |
| S384-1Z | 63676 | Set of 4 Pairs – Sizes N, M, P, F – In Case |
| S384-2Z | 63677 | Set of 4 Pairs – Sizes G, H, R, M – In Case |
| S384-3Z | 63678 | Set of 5 Pairs – Sizes S, T, W, X and Y – In Case |



S384-3Z



PARALLELS

154 ADJUSTABLE PARALLELS

3/8 – 2-1/4"/9.5-57MM

These adjustable parallels provide a wide range of use in layout, gaging, inspection work and for setups on various machine tools. Their adjustability makes it possible to adjust them to exact size by micrometer measurement and also permits use in place of several solid-type parallels.

These parallels are useful as gages in checking the size of slots and openings. They are also convenient for use in machine vises, for leveling or adjusting work on setups of milling and grinding machines, shapers, planers, drill presses and for many other applications.

Parallels slide smoothly and can be easily adjusted. The smaller sizes A, B, and C, are locked by one screw while the larger sizes, D, E, and F, have two lock screws. All parallels are 9/32" (7mm) thick.



Set S154LZ with 154E in foreground

| 154 Adjustable Parallels | | | | | |
|--------------------------|-------|----------------|-----------|---------|-----|
| Cat. No. | EDP | Range | | Length | |
| | | in | mm | in | mm |
| 154A | 50578 | 3/8 – 1/2 | 9.5-12.7 | 1-3/4 | 45 |
| 154B | 50579 | 1/2 – 11/16 | 12.7-17.5 | 2-1/8 | 55 |
| 154C | 50580 | 11/16 – 15/16 | 17.5-24 | 2-11/16 | 70 |
| 154D | 50581 | 15/16 – 1-5/16 | 24-33 | 3-9/16 | 90 |
| 154E | 50582 | 1-5/16 – 1-3/4 | 33-44 | 4-3/16 | 105 |
| 154F | 50583 | 1-3/4 – 2-1/4 | 44-57 | 5-1/16 | 130 |

| 154 Adjustable Parallel Sets | | |
|------------------------------|-------|---|
| Cat. No. | EDP | Description |
| S154SZ | 50584 | Set of 4 parallels – Sizes A, B, C, D – In case |
| S154LZ | 50586 | Set of 6 parallels – Sizes A, B, C, D, E, F – In case |
| S154SZZ | 55194 | Case only for set of 4 |
| S154LZZ | 55195 | Case only for set of 6 |



Checking inside measurement of slot with parallel and outside micrometer





**PROTRACTORS,
ANGLE MEASUREMENT**

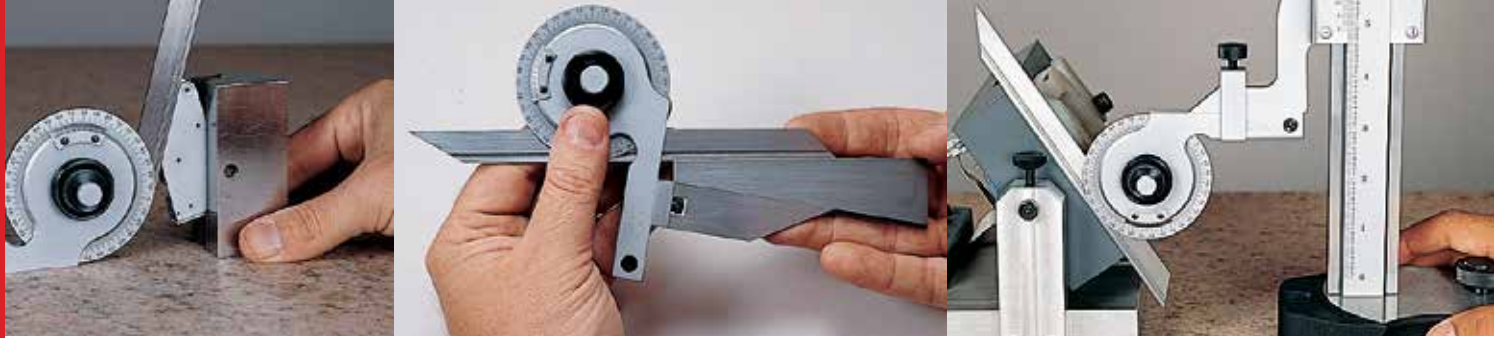

PROTRACTORS

359 PRECISION UNIVERSAL BEVEL VERNIER PROTRACTORS WITH FINE ADJUSTMENT

GRADUATIONS IN DEGREES THRU 360°

These tools are designed for precision measuring and for laying out angles. The protractor is one of the most valuable and useful tools for the kit of every good toolmaker, inspector or machinist.

359 Precision Universal Bevel Vernier Protractors - Graduations in Degrees through 360°

| In Case | | | |
|---------------|-------|------------|-----------------------|
| Cat. No. | EDP | Blade Size | Graduation |
| C359BZ | 51394 | 7" | 5 min. or 1/12 degree |
| C359DZ | 51396 | 12" | 5 min. or 1/12 degree |
| C359FZ | 51398 | | |
| C359FZ W/SLC* | 66929 | 7" and 12" | 5 min. or 1/12 degree |

Accessories for 359 Precision Universal Bevel Vernier Protractors

| Cat. No. | EDP | Description |
|----------|-------|-----------------------------|
| PT04780 | 70538 | 7" Blade Only |
| PT04781 | 70539 | 12" Blade Only |
| PT99329 | 51392 | Acute Angle Attachment Only |

* Includes redemption card for Standard Letter of Certification (SLC).

READABILITY FEATURES

- Satin chrome finish on all reading surfaces – eliminates glare and resists rust
- Sharp, machine-divided graduations

EASE-OF-HANDLING FEATURES

- Available with hardened 7" (175mm) or 12" (300mm) blades which can be rotated to the desired angle and adjusted to the desired length
- Both the dial and the blade can be locked independently
- An acute angle attachment is available
- Flush surfaces on the base permits use on height gages
- One side of the tool is flat so it can be laid on paper or on the work

ACCURACY FEATURES

- Machine-divided graduations read to 5 minutes (1/12 of a degree) and accuracy is finer than can be read
- The most convenient, ultra-sensitive fine adjustment for precision setting

HOW TO READ A VERNIER ON UNIVERSAL BEVEL PROTRACTORS

Universal Bevel Protractors with Vernier can be accurately read to 5 minutes (5') or 1/12 of a degree. The dial of the protractor is graduated both to the right and left of zero up to 90 degrees. The Vernier scale is also graduated to the right and left of zero up to 60 minutes (60'), each of the 12 Vernier graduations representing 5 minutes. Any angle can be measured, and remember that the Vernier reading must be read in the same direction from zero as the protractor, either left or right.

Since 12 graduations on the Vernier scale occupy the same space as 23 graduations or 23 degrees on the protractor dial, each Vernier graduation is 1/12 degree or 5 minutes shorter than 2 graduations on the protractor dial. Therefore, if the zero graduation on the Vernier scale coincides with a graduation on the protractor dial, the reading is in exact degrees, but if some other graduation on the Vernier scale coincides with a protractor graduation, the number of Vernier graduations multiplied by 5 minutes must be added to the number of degrees read between the zeros on the protractor dial and Vernier scale.

EXAMPLE:

★ In the illustration on the below, the zero on the Vernier scale lies between the "50" and "51" on the protractor dial to the left of the zero, indicating 50 whole degrees. Also reading to the left, the 4th line on the Vernier scale coincides with a graduation on the protractor dial as indicated by the stars (★) and therefore 4 x 5 minutes or 20 minutes are to be added to the number of degrees. The reading of the protractor therefore, is 50 degrees and 20 minutes (50° 20').



STEEL PROTRACTORS

C19 STEEL PROTRACTOR

0-180°

This is a highly useful and accurate tool for setting bevels, transferring angles, small squaring tasks, checking cutter clearances within certain limits, and many other applications.

- Double graduations from 0-180° in opposite directions permitting the direct reading of angles and supplementary angles
- The back of the tool is flat for ease of use
- The blade can be locked firmly at any angle by the lock nut
- Satin chrome finish for ease of reading and resistance to rust

C183 STEEL PROTRACTOR

0-180°

This protractor is exactly the same as the C19, except that it has a rectangular head, thus providing four convenient working edges.

C182 STEEL PROTRACTOR

0-180°

This protractor has the same type of head as our C19 but it is designed for draftsmen, civil engineers, and others who need a protractor that will allow the drawing of any number of radial lines at any angle through a common center. This is especially useful for someone in the field who can only carry a minimum of equipment. Weight is approximately 3 ounces.

To use the protractor, the fulcrum point is pressed into the drawing at the required center. This is done by removing the fulcrum point from the hub, pressing it in the drawing, and then placing the protractor hub over the fulcrum point. The desired angles can then be laid out.

The fulcrum point can be left in the tool. Press the whole tool down so that the point penetrates the drawing. (However, this will make it harder to find the center.)

When not in use, the fulcrum point can be drawn back into the hub and frictionally held in a safe position.

Satin chrome finish for ease of reading and resistance to rust.

Furnished with one needle point and one cone point.

| Steel Protractors | | | |
|-------------------|-------|--------------|--------|
| Cat. No. | EDP | Blade Length | Range |
| C19 | 50127 | 6" | 0-180° |
| C183 | 50672 | | |
| C183 W/SLC* | 66930 | | |
| C182 | 64361 | | |

* Includes redemption card for Standard Letter of Certification (SLC).



Side view of protractor with fulcrum point in place

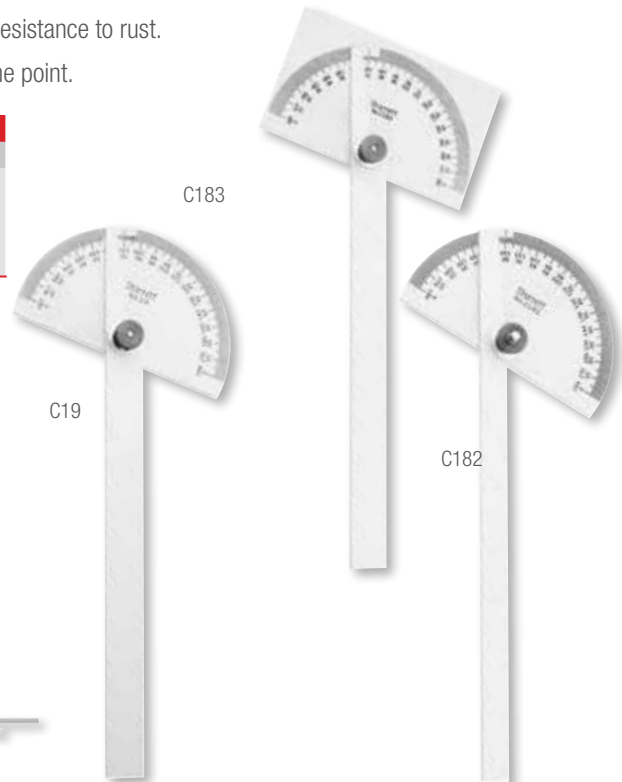

PROTRACTORS

193 STEEL PROTRACTOR

0-180°

This protractor can be used with the 47 Universal Bevel by setting it against the revolving stud, which quickly and economically converts it into a Bevel Protractor. Protractor has double graduations from 0-180° in opposite directions.

| Steel Protractor | | |
|------------------|-------|--------|
| Cat. No. | EDP | Range |
| 193 | 50696 | 0-180° |



193

47 UNIVERSAL BEVEL

6"/150MM

This improved Universal Bevel has both offset and straight slots in the blade, in combination with straight slots in the stock that allow for a wide variety of adjustment and angle settings that are impossible to obtain with many ordinary bevels.

Length of the blade is 6" (150mm), and the stock, 3-1/2" (90mm). The stock lies flat on the work or paper since the head of the clamping bolt is recessed. This tool can be set to duplicate an angle from a master, or it may be easily converted into a Bevel Protractor by using this tool with the 193 Protractor.

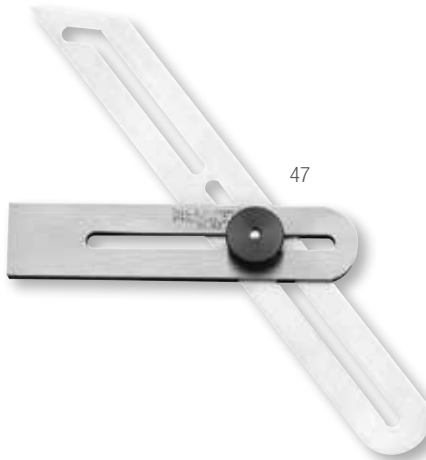

47

| Universal Bevel | | |
|-----------------|-------|--------------|
| Cat. No. | EDP | Blade Length |
| 47 | 50266 | 6" |



SPECIAL DIAL PROTRACTOR HEADS

We make dial protractor heads for special applications that permit rapid angular measurements over a 90° range, in increments of 5 minutes.

These special tools are similar to AGD Group-2 Dial Indicators. They have a rear-mounted rotary input shaft attached to a movable arm that measures the angle in relation to a fixed arm.

They are available with continuous or balanced dials and with clockwise or counterclockwise reading. (See our Special Gage section for more information.)

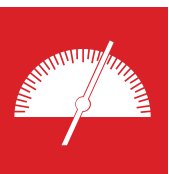

PROTRACTORS

493 PROTRACTOR AND DEPTH GAGES

0-180°

The ability to measure angles and depths is combined in these convenient tools.

C493

- Angular measurement is from 0-180° in opposite directions allowing the direct reading of angles and supplementary angles
- Depths are measured from a 6" (150mm) blade (our C610N)
- Both tools have a flat surface on the back of the head permitting laying the tool flat on paper or work
- No-glare satin chrome finish
- Semicircular head

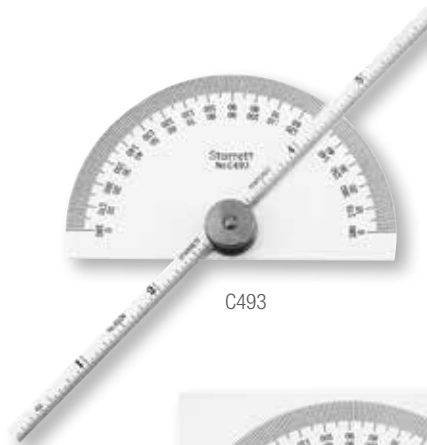

C493

C493B

This gage is exactly the same as the C493, except that it has a rectangular protractor head which provides four convenient working edges.



C493B

| C493 Protractor and Depth Gages | | | | |
|---------------------------------|-------|--------------|-------------------|--------|
| Cat. No. | EDP | Blade Length | Blade Graduations | Range |
| C493 | 52532 | 6" | 32nds, 64ths | 0-180° |
| C493B | 52534 | | | |
| Replacement Blades | | | | |
| Cat. No. | EDP | Blade Length | | |
| C610N-6 | 52696 | 6" | | |
| C610N-12 | 67103 | 12" | | |

22C DRILL POINT GAGE

59°

This gage was designed specifically for use in drill grinding. It provides a quick, accurate way for determining the correct drill point angle of 59° and the correct length of drill lips necessary for clean-cut drilling at maximum feeds and speeds.

- The sliding head may be adjusted to any position along the rule and locked by a thumb nut
- The head is beveled to 59° (the correct drill point angle), and is also graduated in 32nds along the 59° face for measuring the drill lips which should be of equal lengths
- The hook rule has accurate, machine-divided graduations in 8ths, 16ths, quick-reading 32nds and 64ths
- Hook is adjustable and can be shortened or extended on either side of the rule, and may also be removed if desired
- Tool can also be used as a Plain Rule, Hook Rule, Depth Gage, and Slide Caliper
- Will handle up to a 2" diameter drill

| 22C Drill Point Gage | | | | | |
|----------------------|-------|------------|-------------|------------------|---|
| Cat. No. | EDP | Head Bevel | Graduations | Hook Rule Length | Graduations |
| 22C | 50150 | 59° | 32nds | 6" | 8ths, 16ths; Quick-Reading 32nds, 64ths |

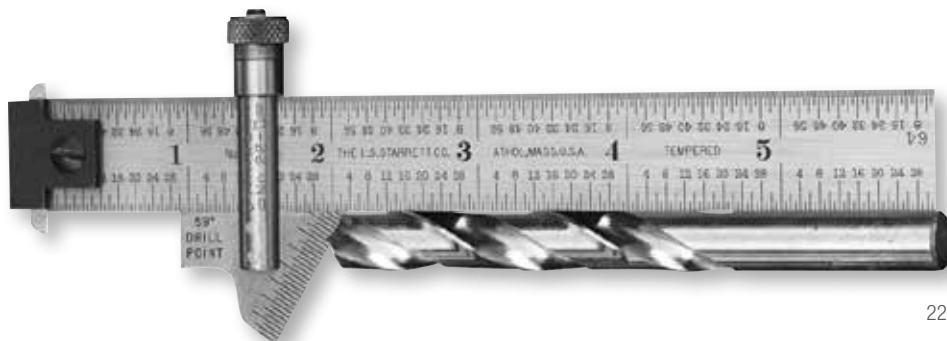

22C



BEVEL PROTRACTORS

490, 491 REVERSIBLE BEVEL PROTRACTORS

0-180°

12 NON-REVERSIBLE BEVEL PROTRACTORS

0-180°



Close-up of spirit level on back side of protractor

READABILITY FEATURES

- Starrett satin chrome blades and protractor heads for easier reading are available (on 12" sizes)
- Direct reading 0-180° in opposite directions, permitting the direct reading of angles and supplementary angles

EASE-OF-HANDLING FEATURES

- Reversible lock bolt allows choice of which graduated side of the blade faces the operator
- The 12 is non-reversible, meaning the blade is on the outside of the frame, so the frame stays on the same side of the workpiece
- The 490 and 491 are reversible, meaning there is a shoulder on both sides of the blade, allowing the tool to be reversed so the same angle can be scribed or measured left and right

LONG-LIFE AND ACCURACY FEATURES

- Protractor heads are made of stable cast iron and finished with a choice of attractive black wrinkle finish or smooth black finish
- Tempered steel blades with accurate, photo-engraved graduations
- A spirit level indicates when the base reference surface is level – a feature not usually available on comparable protractors

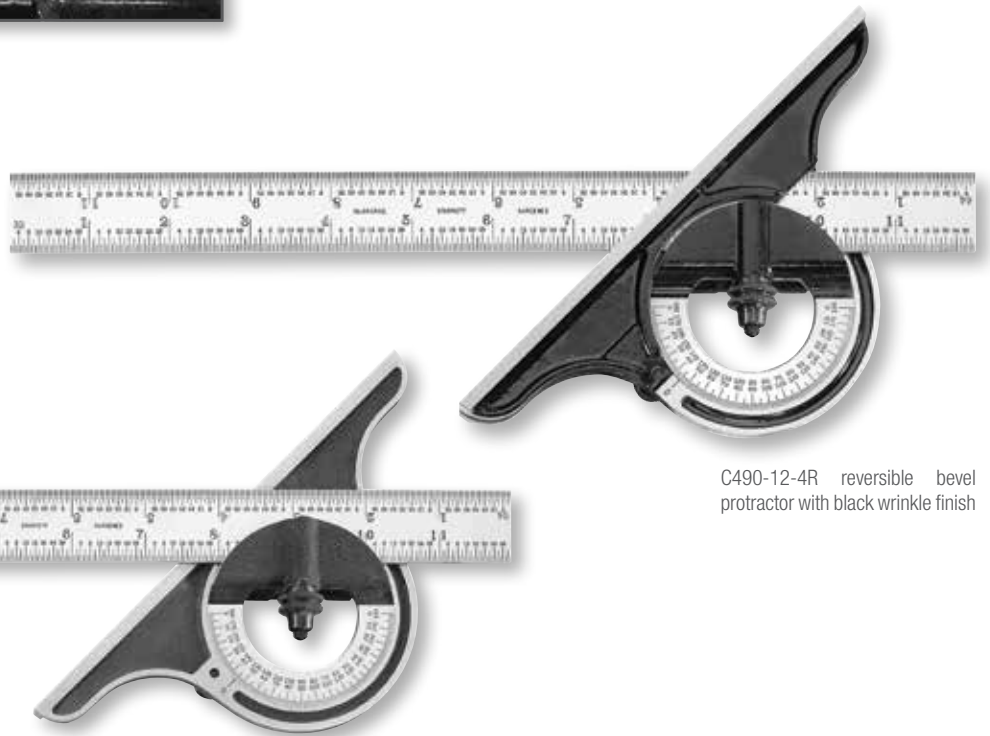

C12-12-4R non-reversible bevel protractor with smooth finish

C490-12-4R reversible bevel protractor with black wrinkle finish

| Bevel Protractors | | | | | | | | | | |
|----------------------|-------|---------------------|-------|----------------------|-------|-------------------|--------------|--|--------------|------------|
| Reversible | | | | Non-reversible | | | | Size | Blade Finish | Graduation |
| Black Wrinkle Finish | | Black Smooth Finish | | Black Wrinkle Finish | | | | | | |
| Cat. No. | EDP | Cat. No. | EDP | Cat. No. | EDP | | | | | |
| C491-12-4R | 64602 | C490-12-4R | 52514 | C12-12-4R | 64290 | 12" | Satin Chrome | 4R: 8ths, 16ths, Quick Reading, 32nds, 64ths | | |
| | | | | C12-12-4R W/SLC* | 66931 | | | | | |
| 491-12-4R | 52521 | 490-12-4R | 52511 | 12-12-4R | 50103 | 12" | Regular | 4R: 8ths, 16ths, Quick Reading, 32nds, 64ths | | |
| 491-18-4R | 52522 | 490-18-4R | 52512 | 12-18-4R | 50104 | 18" | Regular | 4R: 8ths, 16ths, Quick Reading, 32nds, 64ths | | |
| 491-24-4R | 52523 | 490-24-4R | 52513 | 12-24-4R | 50105 | 24" | Regular | 4R: 8ths, 16ths, Quick Reading, 32nds, 64ths | | |
| 491ME-300 | 52524 | | | 12ME-300 | 50106 | 300mm and 11-3/4" | Regular | 1/2mm and 32nds one side; mm and 64ths, reverse side | | |

Since the protractor heads and blades are furnished with combination square sets, individual protractor heads or blades can be ordered separately. See the Squares section for information and catalog numbers.
 * Includes redemption card for Standard Letter of Certification (SLC).



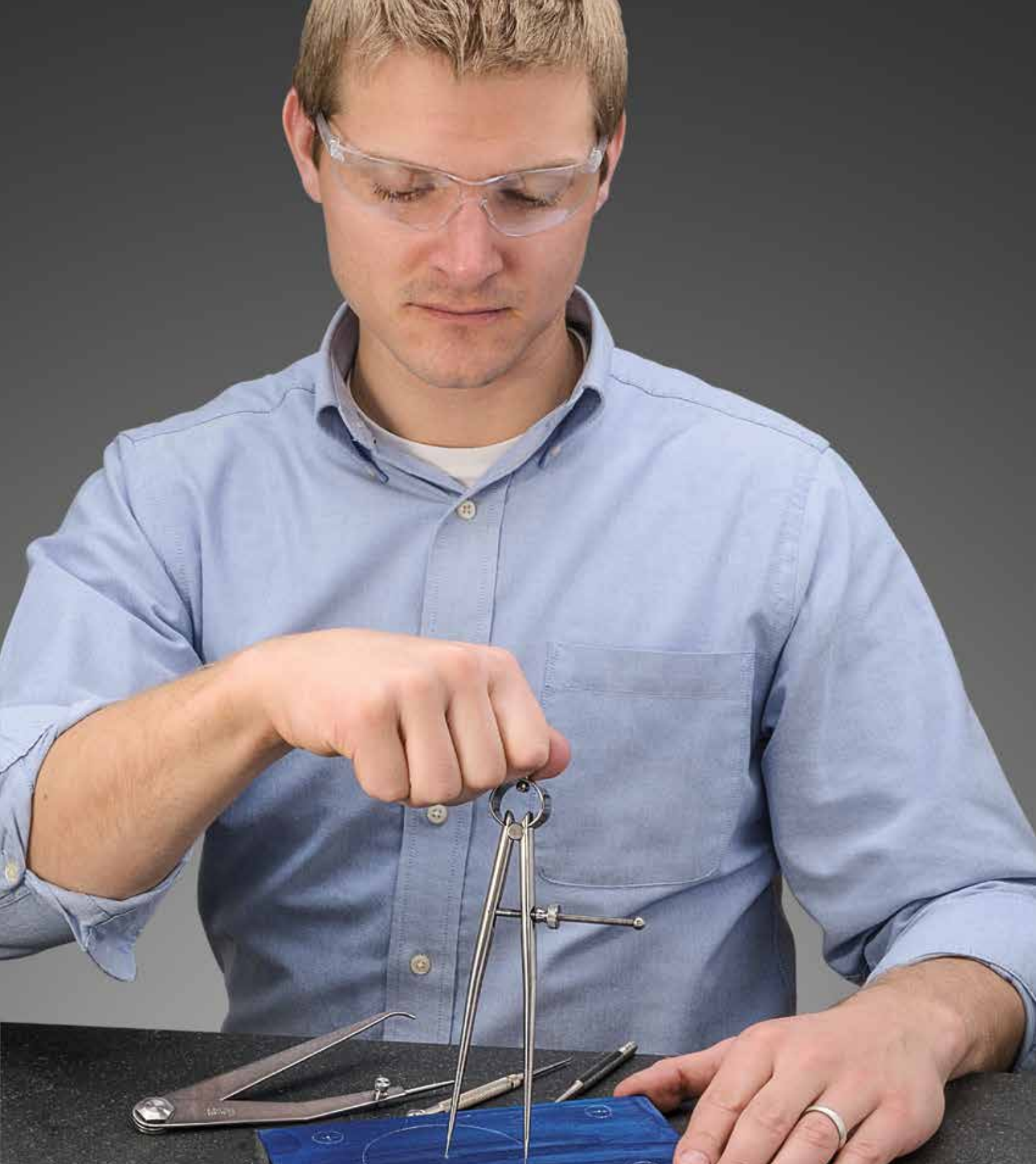

**CALIPERS, DIVIDERS
AND TRAMMELS**

SPRING-TYPE CALIPERS

274, 275, 277 TOOLMAKERS' SPRING-TYPE CALIPERS AND DIVIDERS WITH ROUND LEGS AND SOLID NUT

3, 6"/75, 150MM

Toolmakers' Calipers and Dividers are the finest tools of their type. Designed for toolmakers and all good mechanics who require finer adjustment and better balance so a more sensitive "feel" can be obtained. Precision made to rigid Starrett standards throughout.

The fulcrum stud is hardened and the bearing surfaces of the legs are large enough to prevent any side deflection. The bow spring is strong and flexible, and the adjustment is centrally located in the legs to assure smooth action.

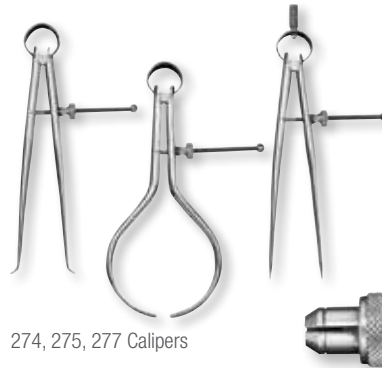

274, 275, 277 Calipers

Quick-adjusting spring nut

274, 275, 277 Toolmakers' Spring-Type Calipers and Dividers*

| Inside Calipers | | Outside Calipers | | Dividers | | Size and Approx. Capacity | |
|-----------------|-------|------------------|-------|----------|-------|---------------------------|-----|
| Cat. No. | EDP | Cat. No. | EDP | Cat. No. | EDP | in | mm |
| 274-3 | 51301 | 275-3 | 51305 | 277-3 | 51309 | 3 | 75 |
| 274-6 | 51303 | 275-6 | 51307 | 277-6 | 51311 | 6 | 150 |

*Not available with spring nut

73, 79, 83 "YANKEE" SPRING-TYPE CALIPERS AND DIVIDERS WITH FLAT LEGS AND QUICK-SPRING OR SOLID NUT

4, 6, 8, 12"/100, 150, 200, 300MM

"Yankee" Calipers and Dividers are made from a high-grade steel and well-finished. The legs are made of flat stock and are very durable. The fulcrum stud is hardened and has a smooth bearing surface. The bow spring, although flexible, is exceedingly strong to assure reliability.

All sizes are available with either spring nut or solid nut. The Starrett quick-adjusting automatic-closing spring nut is designed for making fast, positive adjustments. The threads of the nut firmly engage the screw at the slightest pressure from the leg. When the pressure is withdrawn, the nut automatically releases itself, sliding freely over the screw. This feature saves time in opening and closing.



73, 79, 83 Calipers

73 "Yankee" Spring-Type Inside Calipers

| Solid Nut | | Quick-Spring Nut | | Size and Approx. Capacity | |
|-----------|-------|------------------|-------|---------------------------|-----|
| Cat. No. | EDP | Cat. No. | EDP | in | mm |
| 73A-4 | 50334 | 73B-4 | 50335 | 4 | 100 |
| 73A-6 | 50336 | 73B-6 | 50337 | 6 | 150 |
| 73A-8 | 50338 | 73B-8 | 50339 | 8 | 200 |
| 73A-12 | 50342 | 73B-12 | 50343 | 12 | 300 |

79 "Yankee" Spring-Type Outside Calipers

| Solid Nut | | Quick-Spring Nut | | Size and Approx. Capacity | |
|-----------|-------|------------------|-------|---------------------------|-----|
| Cat. No. | EDP | Cat. No. | EDP | in | mm |
| 79A-4 | 50364 | 79B-4 | 50365 | 4 | 100 |
| 79A-6 | 50366 | 79B-6 | 50367 | 6 | 150 |
| 79A-8 | 50368 | 79B-8 | 50369 | 8 | 200 |
| 79A-12 | 50372 | 79B-12 | 50373 | 12 | 300 |

83 "Yankee" Spring-Type Dividers

| Solid Nut | | Quick-Spring Nut | | Size and Approx. Capacity | |
|-----------|-------|------------------|-------|---------------------------|-----|
| Cat. No. | EDP | Cat. No. | EDP | in | mm |
| 83A-4 | 50376 | 83B-4 | 50377 | 4 | 100 |
| 83A-6 | 50378 | 83B-6 | 50379 | 6 | 150 |
| 83A-8 | 50380 | 83B-8 | 50381 | 8 | 200 |
| 83A-12 | 50384 | 83B-12 | 50385 | 12 | 300 |



HERMAPHRODITE CALIPERS

243 FIRM-JOINT HERMAPHRODITE CALIPERS

6"/150MM

This caliper features a round, adjustable leg and an improved firm-joint, which allows the joint to be adjusted at any tension. The leg that holds the adjustable point is offset.

563 FIRM-JOINT HERMAPHRODITE CALIPERS

6"/150MM

This caliper has a round, adjustable point held by a straight leg. An improved, firm-joint feature permits the joint to be adjusted at any desired tension.

42 LOCK-JOINT HERMAPHRODITE CALIPERS WITH FINE-ADJUSTMENT

6, 8"/150, 200MM

These calipers have an adjustable point, locking joint and fine-adjustment feature for close measurements. After the legs have been set to approximate size and the joint locked, the final adjustment is made by a few turns of the knurled adjusting nut.

HERMAPHRODITE CALIPERS

Starrett Hermaphrodite Calipers are used in layout work for locating and testing centers, laying out distances from an edge, etc.

We offer a complete choice from which machinists and toolmakers can select to best suit their requirements.

The rugged, properly shaped legs are made of finely finished, high-grade steel.

Sizes listed are the lengths of the legs.

Actual measuring capacity is approximately one-third greater than the leg size.

243 and 563 Firm-Joint Hermaphrodite Calipers

| Cat. No. | EDP | Size* | |
|----------|-------|-------|-----|
| | | in | mm |
| 243-6 | 51143 | 6 | 150 |
| 563-6 | 52572 | | |

42 Lock-Joint Hermaphrodite Calipers

| Cat. No. | EDP | Size* | |
|----------|-------|-------|-----|
| | | in | mm |
| 42-6 | 50263 | 6 | 150 |
| 42-8 | 50264 | 8 | 200 |

* Actual capacity is one-third greater than the listed size.



FIRM AND LOCK-JOINT CALIPERS

IMPROVED FIRM-JOINT CALIPERS

26 (OUTSIDE)

6-36"/150-900MM

27 (INSIDE)

6-24"/150-600MM

- Improved joint designed for tension adjustment
- Tension will not change with leg movement
- Legs are made from a high-grade steel, are ruggedly constructed and well-finished



LOCK-JOINT CALIPERS WITH FINE-ADJUSTMENT

38 (OUTSIDE) AND 39 (INSIDE)

6-24"/150-600MM

- Joint can be quickly and firmly locked by a partial turn of the large knurled disc
- Spring washer under the disc maintains proper leg tension when joint is unlocked
- Provided with an adjusting screw to permit fine-adjustments for close measurements
- Once legs have been set to approximate size and joint locked, final adjustment is made by a few turns of the knurled adjusting nut
- Legs are made of well shaped high-grade steel and are ruggedly constructed and nicely finished



LOCK-JOINT TRANSFER TYPE CALIPERS WITH FINE-ADJUSTMENT

36 (OUTSIDE) AND 37 (INSIDE)

6-24"/150-600MM

One of the handiest and most versatile calipers ever made, Starrett Lock-Joint Transfer Calipers feature a transfer arm, a fine-adjustment screw, and a locking joint.

- Transfer arm allows transfer measurements from places where it is necessary to move the legs after they have been set to size
- Adjusting screw permits close adjustment for fine measurements
- Once legs have been set to approximate size and the joint locked, final adjustment is made with a few turns of the knurled adjusting nut
- Joint can be quickly and firmly locked by a partial turn of the large knurled disc
- Spring washer under the disc maintains proper tension of legs when joint is loosened
- Ruggedly constructed legs from high-grade steel and are well-shaped and nicely finished



Firm and Lock-Joint Calipers

| 26 Outside Calipers | | 27 Inside Calipers | | 36 Outside Calipers | | 37 Inside Calipers | | 38 Outside Calipers | | 39 Inside Calipers | | Size* | |
|---------------------|-------|--------------------|-------|---------------------|-------|--------------------|-------|---------------------|-------|--------------------|-------|-------|-----|
| Cat. No. | EDP | Cat. No. | EDP | Cat. No. | EDP | Cat. No. | EDP | Cat. No. | EDP | Cat. No. | EDP | in | mm |
| 26-6 | 50186 | 27-6 | 50193 | 36-6 | 50245 | 37-6 | 50249 | 38-6 | 50253 | 39-6 | 50257 | 6 | 150 |
| 26-12 | 50189 | 27-12 | 50196 | 36-12 | 50246 | 37-12 | 50250 | 38-12 | 50254 | 39-12 | 50258 | 12 | 300 |
| 26-18 | 50190 | 27-18 | 50197 | | | | | | | | | 18 | 450 |
| 26-24 | 50191 | 27-24 | 50198 | 36-24 | 50248 | 37-24 | 50252 | 38-24 | 50256 | 39-24 | 50260 | 24 | 600 |
| 26-36 | 50192 | | | | | | | | | | | 36 | 900 |

* Actual capacity is one-third greater than the listed size.



TRAMMEL HEADS

59 TRAMMEL HEADS, DIVIDER POINTS, ATTACHMENTS

The 59 Trammel Head is very useful for laying out and scribing circles beyond the capacity of ordinary dividers. The trammel heads have a clamping device that firmly holds various attachments.

The attachments consist of two sizes of caliper legs, 6", 9-1/2" (150, 238mm), two sizes of divider points 6", 9" (150, 225mm) which are eccentric for close settings, and a set of four ball points with holder. The ball points with 6" (150mm) holder are for scribing circles from the center of any hole up to 1-1/2" (38 mm) in diameter. One of the large caliper legs features a joint operated by an eccentric thumb piece for fine adjustments. A pencil may be clamped in either head in place of the caliper legs or divider points.

The heads will accommodate any size beam from 3/4 – 1-1/2" (19-38mm) in width. Since beam length requirements vary widely, and they are easy for the user to fashion, we do not furnish a beam.

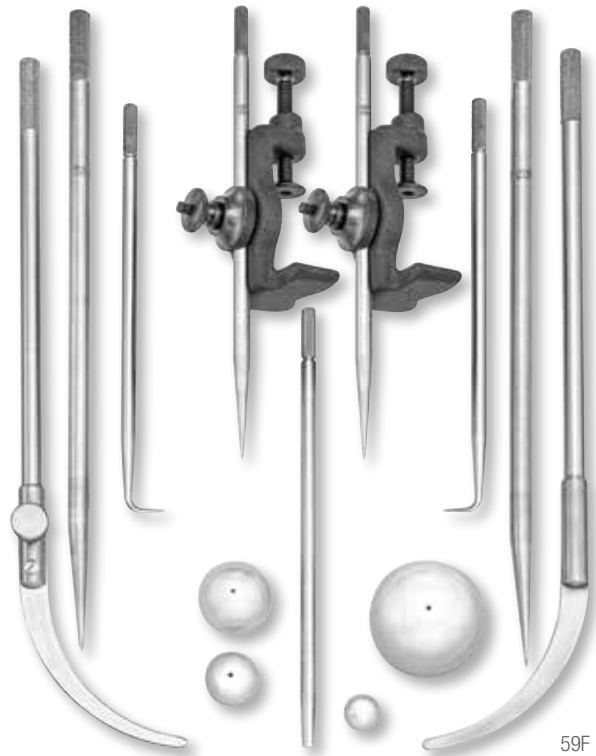

59F

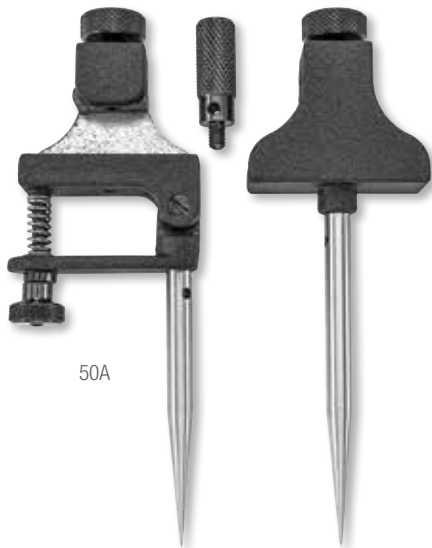

50A

50 IMPROVED TRAMMEL HEADS WITH DIVIDER POINTS, PENCIL SOCKET

Used to measure the distance between points that are too great to be reached with dividers. The heads are die cast with black wrinkle finish and have hardened, forged steel divider points. The points screw into the heads, and the pencil socket accompanying each set of trammel heads can be used in place of either point. 50A has an adjustable point. Longer points (5"/125mm) are also available. A beam is not furnished with these trammels. The heads will accommodate a beam up to 3/8" (9.5mm) thick and 3/4" (19mm) wide.

50 Improved Trammel Heads

| Cat. No. | EDP | Point Size | | Description |
|----------|-------|------------|--------|--|
| | | in | mm | |
| 50A | 50268 | 3, 2-1/2 | 75, 63 | (adjustable) Includes 2 heads, 2 points, pencil socket |
| 50B | 50269 | 3 | 75 | Includes 2 heads, 2 points, pencil socket |

50 (Longer) Points Only

| Cat. No. | EDP | Point Size | | Description |
|----------|-------|------------|----------|--------------------------------------|
| | | in | mm | |
| 50CA | 50270 | 5, 4-1/2 | 125, 113 | 2 adjustable points for Starrett 50A |
| 50CB | 50271 | 5 | 125 | 2 points for Starrett 50B |

59 Trammel Heads, Divider Points, Attachments

| Cat. No. | EDP | Description |
|----------|-------|---|
| 59A | 50297 | 2 trammel heads, 2 small points (6"/150mm) |
| 59B | * | Set of 4 ball points and one holder only |
| 59C | * | Pair small caliper legs only (6"/150mm) |
| 59D | * | Pair large caliper legs only (9-1/2"/228mm) |
| 59E | 50301 | Large points only (9"/225mm) |
| 59F | 50302 | Complete Set: 59A, B, C, D, E |

* 59B, 59C and 59D sold only as part of 59F set.



DIVIDERS

85 EXTENSION DIVIDERS WITH CALIPER LEGS

Exceptionally rigid although light in weight and easy to handle. The head is made of forged steel.

FEATURES

- The hardened points are bent slightly so they can be rotated and brought closer together if desired
- Sturdy construction of the joint eliminates side deflection of the legs
- Quadrant adjusting nut allows fine-adjustments for close measurements

| With Divider - Legs Only | | Complete with Divider Legs, Inside and Outside Legs | | Size* | |
|--------------------------|-------|---|-------|-------|-----|
| Cat. No. | EDP | Cat. No. | EDP | in | mm |
| 85A | 50398 | 85C | 50400 | 7 | 175 |
| 85B | 50399 | 85D | 50401 | 9 | 225 |
| 85E | 50402 | 85F | 50403 | 12 | 300 |



85C



92-6

92 CARPENTERS' DIVIDERS

These dividers combine rigidity, light weight and easy handling. The legs are forged steel, well-shaped, properly tempered and highly polished. The adjustable point may be quickly removed and a common pencil inserted in its place.

FEATURES

- Sturdy construction of the joint eliminates side deflection of the legs
- Quadrant adjusting nut allows fine-adjustments for close measurements
- Check nut located between the legs locks the legs in place

| Cat. No. | EDP | Size* | |
|----------|-------|-------|-----|
| | | in | mm |
| 92-6 | 50423 | 6 | 150 |
| 92-9 | 50426 | 9 | 225 |

*Actual capacity is one-third greater than the listed size.



STEEL BEAM TRAMMELS

C251 STEEL BEAM TRAMMELS AND ATTACHMENTS

10-1/2 – 20"/260 - 500MM BEAMS

A rigid, well-designed trammel for layout, scribing, and measuring distances and circles. The top of the beam is flattened so that when the trams are clamped in position, they will not turn from pressure on the points. The trams are held in place by spring friction, which prevents them from sliding when the nuts are loosened for setting. One tram has a fine-adjusting screw for the points.

Each tram has a knurled swivel grip at the top that turns freely, making it very convenient to swing the tool when scribing circles. The 3" (75mm) points may be adjusted for length in the spring chucks and can be easily replaced with caliper legs or other attachments listed. The ball points with 3" (75mm) holder permit working from holes up to 1-1/2" (38mm) in diameter. A pair of 3" (75mm) caliper points is included with each trammel.

- Ideal for draftsmen, engineers, metal-workers for layout work, scribing and measuring
- Furnished with rigid steel beam – 10-1/2" (263mm), 14-1/2" (360mm) or 20" (500mm) sizes
- Bright chrome finish for longer life, resistance to corrosion
- Highly versatile – handy attachments available to extend range and measure

C251 Steel Beam Trammels

| Cat. No. | EDP | Max. Dividing Range | | Max. Circle Scribing Diameter Range | | Beam Size | |
|----------|-------|---------------------|-----|-------------------------------------|-----|-----------|-----|
| | | in | mm | in | mm | in | mm |
| C251A | 51205 | 9 | 225 | 18 | 450 | 10-1/2 | 263 |
| C251B | 51207 | 13-1/2 | 338 | 26 | 650 | 14-1/2 | 363 |
| C251C | 51209 | 18 | 450 | 36 | 900 | 20 | 500 |

C251 Trammel Individual Attachments Only

| Photo Key | Cat. No. | EDP | Description |
|-----------|----------|-------|---|
| D | C251D | 51211 | Coupling, with extra 20" (600mm) beam (when used with C251C will scribe circle 72" [1800mm] diameter) |
| E | C251E | 51212 | Ball points and holder |
| H | C251H | 51214 | Steel point and socket (one) (has .076" [1.9mm] hole diameter to hold leads) |
| J | 251J | 51203 | Needle point (chrome not available) (one) |

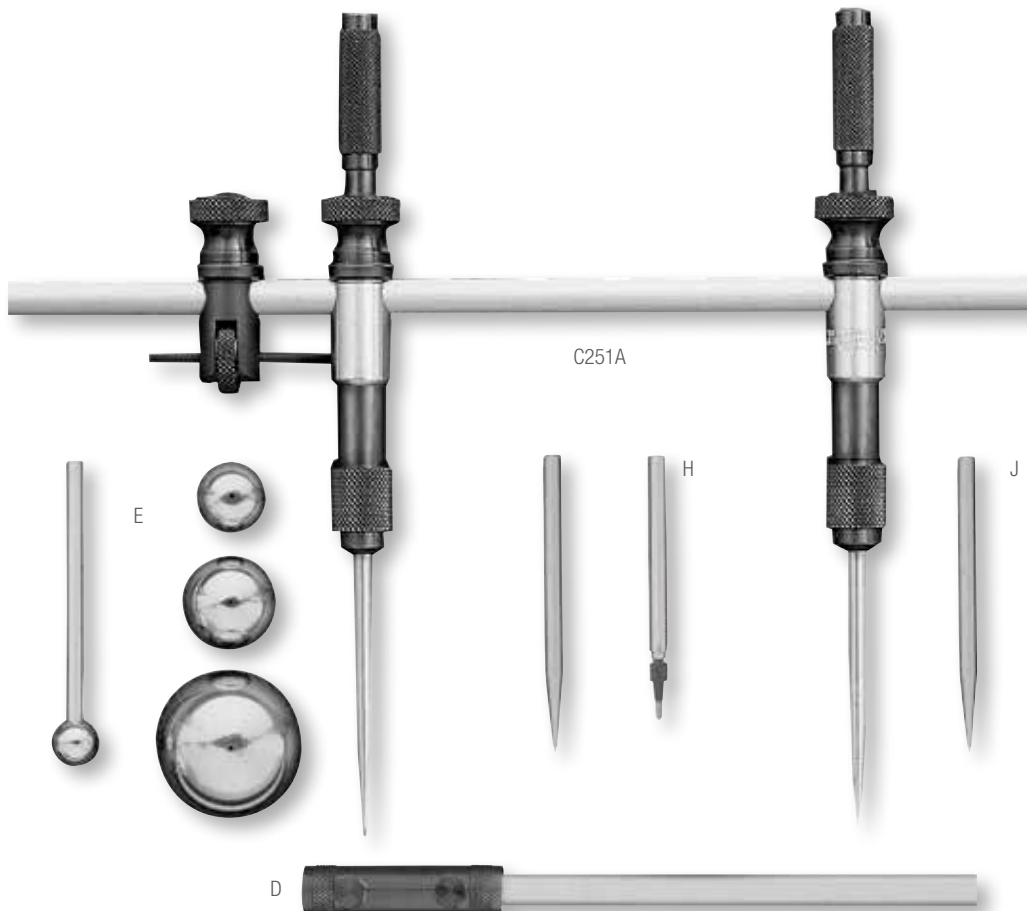



FOR OVER 130 YEARS, WITH INNOVATIVE TECHNOLOGIES.

More than 5,000 products including precision tools, vision systems, force measurement systems, non-contact measurement systems, profile projectors, band saw blades, band saw machines, hand tools and power tools accessories.

Read more: www.starrett.com



Starrett®

(978) 249-3551 • starrett.com

Follow us!





HOLE GAGES, SLOT GAGES

SMALL HOLE GAGES

829 SMALL HOLE GAGES

.125-.500"/3.2-12.7MM

These full-ball gages are used for general work.

| 829 Small Hole Gages | | | | | |
|----------------------|-------|-----------|-----------|----------------|----|
| Cat. No. | EDP | Range | | Approx. Length | |
| | | in | mm | in | mm |
| 829A | 53070 | .125-.200 | 3.2-5.1 | 2-7/8 | 75 |
| 829B | 53071 | .200-.300 | 5.1-7.6 | 3 | 80 |
| 829C | 53072 | .300-.400 | 7.6-10.2 | 3-3/8 | 85 |
| 829D | 53073 | .400-.500 | 10.2-12.7 | 3-1/2 | 90 |

| 829 Small Hole Gage Sets | | |
|--------------------------|-------|------------------|
| Cat. No. | EDP | Description |
| S829EZ | 53074 | Set of 4 in case |

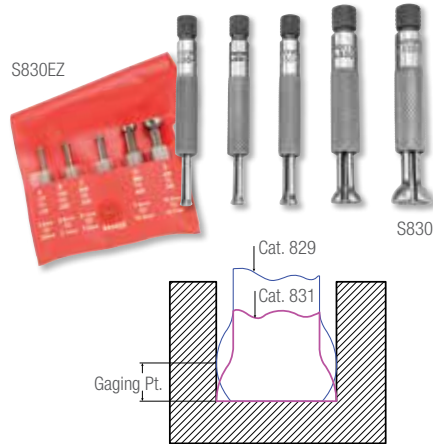

830 SMALL HOLE GAGES

.125-.500"/3.2-12.7MM

These gages are exactly the same as the 831 Small Hole Gage except that all gages are only 2" (50mm) long, making them convenient to use in close quarters.

| 830 Small Hole Gages | | | | | |
|----------------------|-------|-----------|-----------|----------------|----|
| Cat. No. | EDP | Range | | Approx. Length | |
| | | in | mm | in | mm |
| 830A | 53076 | .125-.150 | 3.2-3.8 | 2 | 50 |
| 830B | 53077 | .150-.200 | 3.8-5.1 | | |
| 830C | 53078 | .200-.300 | 5.1-7.6 | | |
| 830D | 53079 | .300-.400 | 7.6-10.2 | | |
| 830E | 53080 | .400-.500 | 10.2-12.7 | | |

| 830 Small Hole Gage Sets | | |
|--------------------------|-------|------------------|
| Cat. No. | EDP | Description |
| S830FZ | 53081 | Set of 5 in case |

831 SMALL HOLE GAGES

.125-.500"/3.2-12.7MM

These gages are exactly the same as the 829 Hole Gage except that the gaging surface is a half-ball with a flat bottom. This permits use in even the most shallow holes, slots, and recesses.

| 831 Small Hole Gages | | | | | |
|----------------------|-------|-----------|-----------|----------------|----|
| Cat. No. | EDP | Range | | Approx. Length | |
| | | in | mm | in | mm |
| 831A | 53083 | .125-.200 | 3.2-5.1 | 2-13/16 | 70 |
| 831B | 53084 | .200-.300 | 5.1-7.6 | 3-1/8 | 80 |
| 831C | 53085 | .300-.400 | 7.6-10.2 | 3-3/8 | 85 |
| 831D | 53086 | .400-.500 | 10.2-12.7 | 3-1/2 | 90 |

| 831 Small Hole Gage Sets | | |
|--------------------------|-------|------------------|
| Cat. No. | EDP | Description |
| S831EZ | 53087 | Set of 4 in case |



SMALL HOLE GAGES

These small hole gages are well balanced tools that are ideal for accurately measuring small holes, slots, grooves, and recesses in all kinds of work. They all feature:

- Hardened-ball measuring surface with two-point contact
- Radius on each gage is less than the minimum diameter to be measured, which provides the two-point contact necessary for maximum accuracy
- Smooth, sensitive adjustment for better feel, giving more accurate measurements
- The adjustment of the gage beyond their range is restricted by a safety stop that prevents breakage

Accurate measurements are obtained by slightly "rocking" these gages in the hole to be measured. This will guarantee contact at the true diameter. The final size is then obtained by measuring over the ball contacts with a micrometer.



TELESCOPING GAGES

229 TELESCOPING GAGES WITH ONE TELESCOPING ARM

1/2-6"/13-150MM

- Features a handle, one rigid contact arm and one spring-tensioned telescoping contact arm

229 Telescoping Gages

| Cat. No. | EDP | Range | | Handle Length | |
|----------|-------|---------------|--------|---------------|----|
| | | in | mm | in | mm |
| 229A | 50923 | 1/2 – 3/4 | 13-19 | 2-3/8 | 60 |
| 229B | 50924 | 3/4 – 1-1/4 | 19-32 | | |
| 229C | 50925 | 1-1/4 – 2-1/8 | 32-54 | | |
| 229D | 50926 | 2-1/8 – 3-1/2 | 54-89 | | |
| 229E | 50927 | 3-1/2 – 6 | 89-150 | 3-1/4 | 82 |

229 Telescoping Gage Sets

| Cat. No. | EDP | Description |
|----------|-------|------------------------------------|
| S229FZ | 50928 | Set of 3, 229A, B, C in case |
| S229GZ | 50929 | Set of 5, 229A, B, C, D, E in case |

Handles can be individually ordered and/or ordered in larger sizes such as 8", 12" or longer, similar to 579 Telescoping Gage listing, upon request.
 Handles can be individually ordered and/or ordered in larger sizes such as 8", 12" or longer, similar to 579 Telescoping Gage listing, upon request.



TELESCOPING GAGES

Starrett telescoping gages are used for determining the true size of holes, slots, and recesses up to 6" (150mm). The ends of both contacts are hardened and ground to a radius to allow proper clearance on the smallest hole the gage will enter. These tools must be slightly "rocked" in the hole being measured to ensure that the tool is on the proper diameter before it is locked and withdrawn. The final hole size is obtained by measuring over the gage contacts with a micrometer.

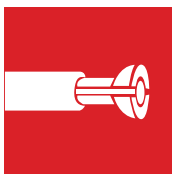

TELESCOPING GAGES

579 SELF-CENTERING TELESCOPING GAGES WITH TWO TELESCOPING ARMS

5/16-6"/8-150MM

- Similar to the 229 Telescoping Gauge with a slightly greater range and two telescoping contacts
- Handles are rigidly attached to the contact plungers and are automatically self-centering
- Constant spring tension gives uniform contact pressure
- Both plungers are easily locked at any desired setting

579 Telescoping Gages

| Cat. No. | EDP | Range | | Handle Length | |
|----------|-------|---------------|--------|---------------|-----|
| | | in | mm | in | mm |
| 579A | 52610 | 5/16 – 1/2 | 8-13 | 2-3/8 | 60 |
| 579A-8 | 63192 | | | 8 | 200 |
| 579A-12 | 63195 | | | 12 | 300 |
| 579B | 52611 | | | 2-3/8 | 60 |
| 579B-8 | 63193 | 1/2 – 3/4 | 13-19 | 8 | 200 |
| 579B-12 | 63196 | | | 12 | 300 |
| 579C | 52612 | | | 2-3/8 | 60 |
| 579C-8 | 63194 | 3/4 – 1-1/4 | 19-32 | 8 | 200 |
| 579C-12 | 63197 | | | 12 | 300 |
| 579D | 52613 | | | 2-3/8 | 60 |
| 579D-8 | 67114 | 1-1/4 – 2-1/8 | 32-54 | 8 | 200 |
| 579D-12 | 63198 | | | 12 | 300 |
| 579E | 52614 | | | 2-3/8 | 60 |
| 579E-8 | 67115 | 2-1/8 – 3-1/2 | 54-89 | 8 | 200 |
| 579E-12 | 63199 | | | 12 | 300 |
| 579F | 52615 | | | 3-1/4 | 82 |
| 579F-8 | 67116 | 3-1/2 – 6 | 89-150 | 8 | 200 |
| 579F-12 | 63200 | | | 12 | 300 |

579 Telescoping Gage Sets

| Cat. No. | EDP | Description |
|----------|-------|---------------------------------------|
| S579GZ | 52616 | Set of 4, 579A, B, C, D in case |
| S579HZ | 52617 | Set of 6, 579A, B, C, D, E, F in case |

Handles can be individually ordered. Handles longer than 12" (300mm) are available on special order.



S579

S579GZ

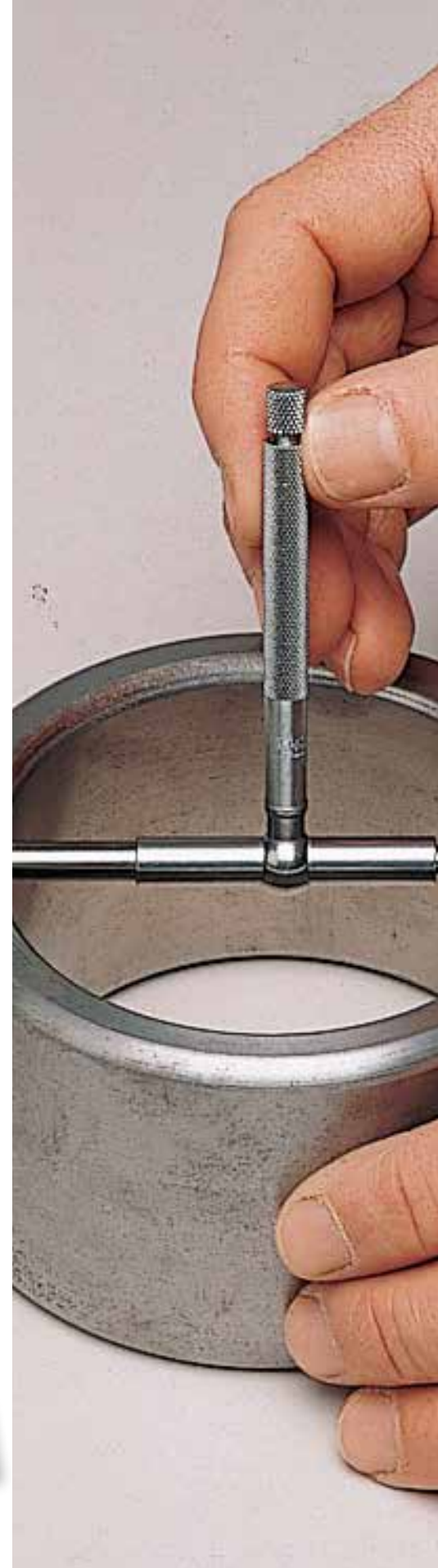

TAPER GAGES

267 TAPER GAGE

1/16 – 1-1/16"

- Specially designed for rapid, accurate checking of inside diameters of tubing
- Also very useful for general gaging of slot widths, hole sizes, setting calipers, etc.
- Thin, tapered leaves graduated to measure inside diameters or widths from 1/16" to 1-1/16" in 64ths of an inch
- Nicely finished spring-tempered steel, approximately 1" wide by 5-1/4" long

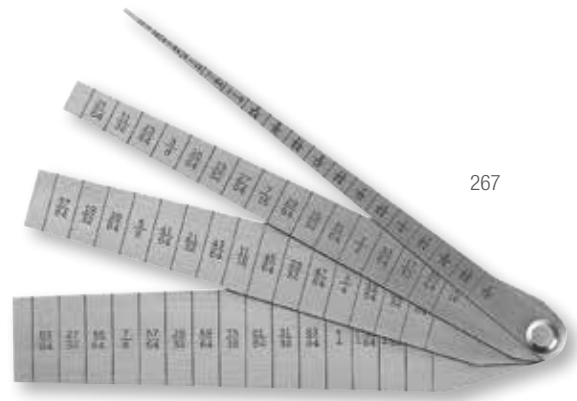

| 267 Taper Gage | | |
|----------------|-------|----------------------------------|
| Cat. No. | EDP | Description |
| 267 | 51286 | Taper Gage, 1/16 – 1-1/16" range |

270 TAPER GAGE

.010-.150"/0.3-4MM

- Very useful tool, especially for bearing work and for gaging slots
- Made of quality tool steel and accurately tapered throughout entire length for quick and convenient measuring
- 7/16" (11mm) wide by 6-1/4" (160mm) long
- Can be used as a precision shim
- One side graduated from .010" to .150" in thousandths of an inch; the reverse side from 0.3mm to 4mm in one-twentieth of a mm (0.05mm)

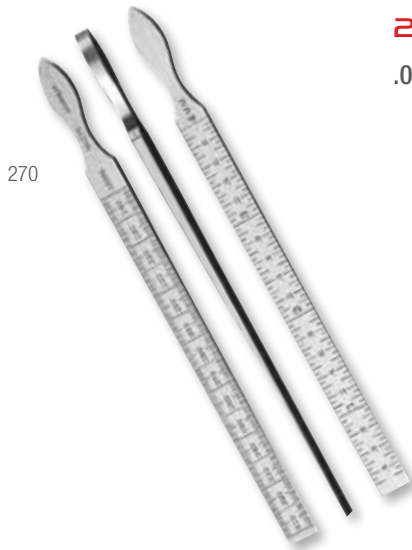

| 270 Taper Gage | | |
|----------------|-------|--|
| Cat. No. | EDP | Description |
| 270 | 51292 | Taper Gage, .010-.150" (0.3-4mm) range |

269, 269M TAPER GAGES

.100-1"/2-25MM

- These gages are for determining hole sizes in dies and all kinds of other work
- Read in thousandths of an inch or 0.02mm
- Made of tempered steel with a locking device for fixing any leaf in position for use

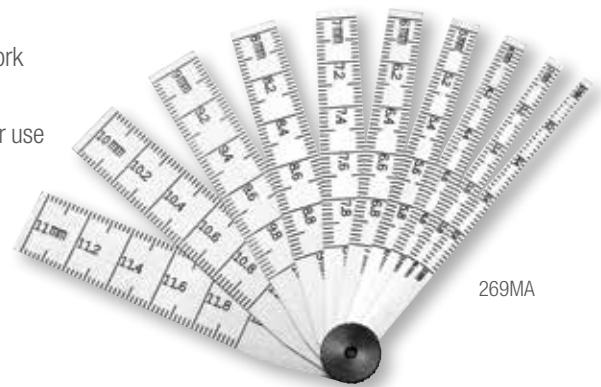

| 269 Taper Gages - .001" Graduation | | | | |
|------------------------------------|-------|------------|--------|--------|
| Cat. No. | EDP | Range | Length | Leaves |
| 269A | 51290 | .100-.500" | 2-1/2" | 8 |
| 269B | 51291 | .500-1" | 2-3/4" | 10 |

| 269M Taper Gages - 0.02mm Graduation | | | | |
|--------------------------------------|-------|---------|--------|--------|
| Cat. No. | EDP | Range | Length | Leaves |
| 269MA | 56031 | 2-12mm | 64mm | 10 |
| 269MB | 56032 | 12-25mm | 70mm | 13 |

TAPER GAGES

These are named "taper" gages only because of their shape. They do not measure taper, but they do measure hole and slot sizes. They are quick to use, very accurate, and are a convenient size.





PRECISION MAKES THE DIFFERENCE

YOUR NAME DEPENDS ON OURS

The CP505E-12 Electronic Protractor is accurate, versatile and easy to use. It eliminates errors from a variety of jobs including complex crown molding work.



Starrett®

(978) 249-3551 • starrett.com

Follow us!





FIXED GAGE STANDARDS

GAGE SETS

S4000 PRECISION STEEL PIN GAGE SETS

.011-1.000"

Precision gage pins are used to determine small hole sizes, for gaging slots, and finding hole distances.

S4000 Pin Gages - Plus Sets

| Cat. No. | EDP | Range | No. of Gages |
|-----------|-------|-----------------|--------------|
| S4000-060 | 67480 | .011-.060" (+) | 50 |
| S4002-250 | 67482 | .061-.250" (+) | 190 |
| S4004-500 | 67484 | .251-.500" (+) | 250 |
| S4006-625 | 67486 | .501-.625" (+) | 125 |
| S4008-750 | 67488 | .626-.750" (+) | 125 |
| S4010-832 | 67490 | .751-.832" (+) | 82 |
| S4012-916 | 67492 | .833-.916" (+) | 84 |
| S4014-1 | 67494 | .917-1.000" (+) | 84 |

S4000 Pin Gages - Minus Sets

| Cat. No. | EDP | Range | No. of Gages |
|-----------|-------|-----------------|--------------|
| S4001-060 | 67481 | .011-.060" (-) | 50 |
| S4003-250 | 67483 | .061-.250" (-) | 190 |
| S4005-500 | 67485 | .251-.500" (-) | 250 |
| S4007-625 | 67487 | .501-.625" (-) | 125 |
| S4009-750 | 67489 | .626-.750" (-) | 125 |
| S4011-832 | 67491 | .751-.832" (-) | 82 |
| S4013-916 | 67493 | .833-.916" (-) | 84 |
| S4015-1 | 67495 | .917-1.000" (-) | 84 |

FEATURES

- Color coded, fully adjustable Go/No-Go gage handle furnished with each set
- Sets are supplied in rugged, high impact protective cases with each space marked for the appropriate gage
- Inspection certificate with every set
- All Starrett pin gages are manufactured to a 0.0002" tolerance
- Plus and minus tolerance sets
 - A plus tolerance gage would be e.g.; gage pin size as labelled + 0.0002" - 0.0"
 - A minus tolerance gage would be the gage pin size as labelled -0.0002" + 0.0
- Offered in 0.001" increments
- Each pin is centerless lapped and is clearly etched with the stated size
- All gages are 2 inches long and hardened to RC 60/64
- All sharp corners are broken

Handles for 4000 Pin Gages

| Cat. No. | EDP | Description |
|----------|-------|----------------------------------|
| PT45065 | 45060 | Handle for .011-.060" Pin Gages |
| PT45250 | 45250 | Handle for .061-.250" Pin Gages |
| PT45500 | 45500 | Handle for .251-.500" Pin Gages |
| PT45625 | 45625 | Handle for .501-.625" Pin Gages |
| PT45750 | 45750 | Handle for .626-.750" Pin Gages |
| PT45832 | 45832 | Handle for .751-.832" Pin Gages |
| PT45916 | 45916 | Handle for .833-.916" Pin Gages |
| PT45066 | 45001 | Handle for .917-1.000" Pin Gages |



S4002-250 190, piece set

HARDENED DRILL AND WIRE GAUGES

185 TIME SAVER® TAP AND DRILL GAGE

NOS. 1-60/.228-.040"

- Correct sizing of tap drill for any common size machine screw tap in "NF" National Fine or "NC" National Coarse Thread
- Leaves the right amount of stock for approximately 65% full thread
- Shows correct drill body size
- 60 holes with number sizes and decimal equivalents
- Black matte finish with information steel stamped on one side and white marked on the reverse side for quick, clear reading
- Carefully tested for accuracy after hardening

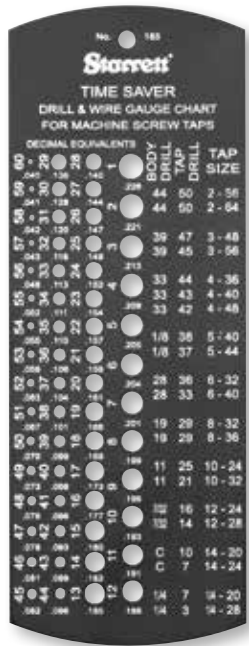

185

186 DRILL AND STEEL WIRE GAGE

NOS. 1-60/.228-.040"

- Widely used by mechanics for twist drills and steel drill rod
- Similar to 185, without the tap and drill information
- 60 holes from 1 to 60
- Marked with number sizes and decimal equivalents
- Black matte finish with gage information steel stamped on one side and white marked on reverse for quick, clear reading
- Carefully tested for accuracy after hardening

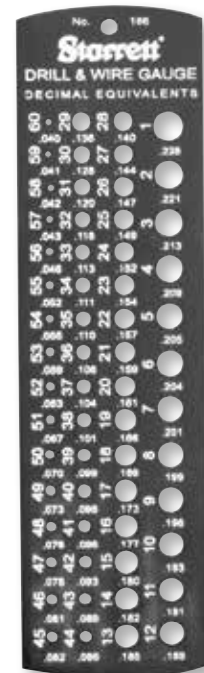

186

185 Time Saver Tap and Drill Gage

| Cat. No. | EDP | Range | | | Dimensions | |
|----------|-------|----------------|-----------|------------|----------------------------|--|
| | | Tap Size | Tap Drill | Body Drill | Thickness x Width x Length | |
| 185 | 50675 | 2-56 to 1/4-28 | 50 to 3 | 44 to 1/4 | 5/64" x 2-5/16" x 6-1/4" | |

Fixed Gages

| Cat. No. | EDP | Dimensions | | Description |
|----------|-------|----------------------------|--|---------------------------|
| | | Thickness x Width x Length | | |
| 186 | 50676 | 5/64" x 1-1/2" x 5-1/2" | | Drill and Steel Wire Gage |

187 JOBBERS' DRILL GAGE

1/16-1/2"

- Quick sizing of any twist drill from 1/16-1/2" by 64ths
- 29 holes marked with drill size in inches and decimal equivalents
- Black matte finish with gage information steel stamped on one side and white marked on reverse for quick, clear reading
- Carefully tested for accuracy after hardening

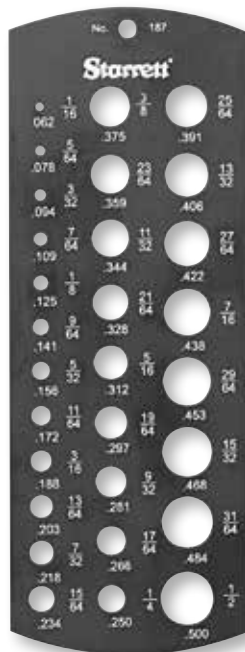

187

198 STANDARD LETTER SIZE DRILL GAGE

A-Z

.234-.413" DIA.

- Quick, convenient checking of letter size drills
- Twenty-six holes provided, giving corresponding drill sizes from "A" through "Z" with decimal equivalents from .234" diameter through .413" diameter
- Satin finish
- Carefully tested for accuracy after hardening



198

Fixed Gages

| Cat. No. | EDP | Dimensions | | Description |
|----------|-------|----------------------------|--|---------------------|
| | | Thickness x Width x Length | | |
| 187 | 50677 | 5/64" x 2-5/16" x 6-1/4" | | Jobbers' Drill Gage |

Fixed Gages

| Cat. No. | EDP | Dimensions | | Description |
|----------|-------|----------------------------|--|---------------------------------|
| | | Thickness x Width x Length | | |
| 198 | 50718 | 5/64" x 2-5/16" x 6-1/4" | | Standard Letter Size Drill Gage |



WIRE AND STANDARD GAGES

286 DRILL AND STEEL WIRE GAGE

HARDENED
61-80/.039-.0135"

This gage is for selecting the correct size of twist drills and steel drill rod in smaller sizes ranging from 61 to 80. For convenience, each hole is marked with the size number and the corresponding decimal equivalent. Attractive satin finish. Small compact size, approximately 1/16" thick, 3/4" wide and 2" long.

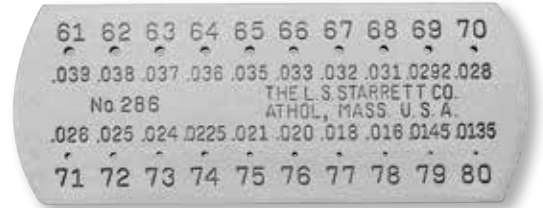

286

| Fixed Gages | | |
|-------------|-------|---------------------------|
| Cat. No. | EDP | Description |
| 286 | 51320 | Drill and Steel Wire Gage |

188 ENGLISH STANDARD WIRE GAGE

(BIRMINGHAM OR STUBS' IRON WIRE GAGE)
HARDENED
1-36/.300-.004"

This gage is popular for gaging iron wire, hot and cold rolled sheet steel, and in some cases, sheet iron by the English Standard Wire system also known as Birmingham or Stubs.

Gage has convenient decimal equivalents of each number on the reverse side. Satin finish.



188

| Fixed Gages | | |
|-------------|-------|----------------------------|
| Cat. No. | EDP | Description |
| 188 | 50678 | English Standard Wire Gage |

281 AMERICAN STANDARD WIRE GAGE

(OR B.&S.) FOR NON-FERROUS METALS
HARDENED
0-36/.325-.005"

This gage is the generally accepted standard for non-ferrous metals as adopted by brass manufacturers. It is especially useful for electricians and others to gage sheet, plate and wire made of non-ferrous metals like copper, brass, aluminum, etc. Screw slotting cutters are also made to this gage.

Gage has decimal equivalents on the reverse side. Satin finish.



281

| Fixed Gages | | |
|-------------|-------|-----------------------------|
| Cat. No. | EDP | Description |
| 281 | 51316 | American Standard Wire Gage |

287 AMERICAN STEEL AND WIRE CO. GAGE

(WASHBURN & MOEN) STANDARD
0-36/.3065-.009"

This gage is designed for gaging steel wire and drill rod to the American Steel & Wire Co. (Washburn & Moen) Standard and checks sizes from 0-36. (Also known as United States Steel Wire Gage.) Decimal equivalents are given on the back. Satin finish.



287

| Fixed Gages | | |
|-------------|-------|---|
| Cat. No. | EDP | Description |
| 287 | 51321 | American Steel and Wire Co. Steel Wire Gage |

280 PIANO TUNERS' GAGE

AMERICAN STEEL AND WIRE CO. STANDARD
HARDENED
12-28/.029-.071"

The 280 Gage is designed for gaging steel music wire and has a range from 12 to 28. Convenient decimal equivalents on reverse side. Diameter of the gage is 1-9/16" and it has a satin finish.



280

| Fixed Gages | | |
|-------------|-------|--------------------|
| Cat. No. | EDP | Description |
| 280 | 51315 | Piano Tuners' Gage |

283 U.S. STANDARD GAGE

SHEET, PLATE IRON AND STEEL GAGE
HARDENED
0-36/.3125-.007"

This gage is made to the United States Standard for uncoated sheet, plate iron and steel, and is based on weights in ounces per square foot. The gage has a satin finish and decimal equivalents on the reverse side.



283

| Fixed Gages | | |
|-------------|-------|--------------------|
| Cat. No. | EDP | Description |
| 283 | 51318 | U.S. Standard Gage |

NOTE: Like other Starrett gages, these tools are carefully tested for accuracy after hardening.



284 ACME STANDARD SCREW THREAD GAGE

HARDENED

29°

This gage is a standard for grinding and setting tools when cutting Acme threads. Acme threads have the same depth as square threads but the sides of the threads are at an inclination of 14-1/2° (29° included angle). This form of thread is used extensively and has in many instances replaced the square thread in machine construction. The advantages of the Acme thread are its strength and the ease by which it can be cut compared with square threads. The angles and edges of this gage are hardened, ground and carefully tested.



284

In use, the angle on the thread cutting tool is checked on the large precision-ground V at the end of the gage. The tool is then ground on the end to the width of the slot of whatever pitch is being turned. It is then set in the lathe using the half angle.

Fixed Gages

| Cat. No. | EDP | Description |
|----------|-------|---------------------------------|
| 284 | 51319 | Acme Standard Screw Thread Gage |

STANDARDS FOR SHEET AND WIRE GAGES WITH CORRESPONDING STARRETT GAGES

Dimensions of Sizes in Decimal Parts of an Inch

| No. of Wire Gage | 281 American or Brown & Sharpe | 188 and 245 Birmingham or Stubs' Iron Wire | 287 Washburn & Moen, Worcester, MA* | 280 American S. & W. Co's. Music Wire Gage | Stubs' Steel Wire | 283 U.S. Standard Gage for Sheet and Plate Iron and Steel |
|------------------|-----------------------------------|--|---|--|-------------------|---|
| 00000000 | 0.7314 | | | | | |
| 0000000 | 0.6514 | | | | | |
| 000000 | 0.5800 | | | 0.004 | | 0.4688 |
| 00000 | 0.5165 | | | 0.005 | | 0.4375 |
| 0000 | 0.46 | 0.454 | 0.3938 | 0.006 | | 0.4063 |
| 000 | 0.4096 | 0.425 | 0.3625 | 0.007 | | 0.375 |
| 00 | 0.3648 | 0.38 | 0.331 | 0.008 | | 0.3438 |
| 0 | 0.3249 | 0.34 | 0.3065 | 0.009 | | 0.3125 |
| 1 | 0.2893 | 0.3 | 0.283 | 0.01 | 0.227 | 0.2813 |
| 2 | 0.2576 | 0.284 | 0.2625 | 0.011 | 0.219 | 0.2656 |
| 3 | 0.2294 | 0.259 | 0.2437 | 0.012 | 0.212 | 0.25 |
| 4 | 0.2043 | 0.238 | 0.2253 | 0.013 | 0.207 | 0.2344 |
| 5 | 0.1819 | 0.22 | 0.207 | 0.014 | 0.204 | 0.2188 |
| 6 | 0.1620 | 0.203 | 0.192 | 0.016 | 0.201 | 0.2031 |
| 7 | 0.1443 | 0.18 | 0.177 | 0.018 | 0.199 | 0.1875 |
| 8 | 0.1285 | 0.165 | 0.162 | 0.02 | 0.197 | 0.1719 |
| 9 | 0.1144 | 0.148 | 0.1483 | 0.022 | 0.194 | 0.1563 |
| 10 | 0.1019 | 0.134 | 0.135 | 0.024 | 0.191 | 0.1406 |
| 11 | 0.0907 | 0.12 | 0.1205 | 0.026 | 0.188 | 0.125 |
| 12 | 0.0808 | 0.109 | 0.1055 | 0.029 | 0.185 | 0.1094 |
| 13 | 0.0720 | 0.095 | 0.0915 | 0.031 | 0.182 | 0.0938 |
| 14 | 0.0641 | 0.083 | 0.08 | 0.033 | 0.18 | 0.0781 |
| 15 | 0.0571 | 0.072 | 0.072 | 0.035 | 0.178 | 0.0703 |
| 16 | 0.0508 | 0.065 | 0.0625 | 0.037 | 0.175 | 0.0625 |
| 17 | 0.0453 | 0.058 | 0.054 | 0.039 | 0.172 | 0.0563 |
| 18 | 0.0403 | 0.049 | 0.0475 | 0.041 | 0.168 | 0.05 |
| 19 | 0.0359 | 0.042 | 0.041 | 0.043 | 0.164 | 0.0438 |
| 20 | 0.0320 | 0.035 | 0.0348 | 0.045 | 0.161 | 0.0375 |
| 21 | 0.0285 | 0.032 | 0.0318 | 0.047 | 0.157 | 0.0344 |
| 22 | 0.0253 | 0.028 | 0.0286 | 0.049 | 0.155 | 0.0313 |
| 23 | 0.0226 | 0.025 | 0.0258 | 0.051 | 0.153 | 0.0281 |
| 24 | 0.0201 | 0.022 | 0.023 | 0.055 | 0.151 | 0.025 |
| 25 | 0.0179 | 0.02 | 0.0204 | 0.059 | 0.148 | 0.0219 |
| 26 | 0.0159 | 0.018 | 0.0181 | 0.063 | 0.146 | 0.0188 |
| 27 | 0.0142 | 0.016 | 0.0173 | 0.067 | 0.143 | 0.0172 |
| 28 | 0.0126 | 0.014 | 0.0162 | 0.071 | 0.139 | 0.0156 |
| 29 | 0.0113 | 0.013 | 0.015 | 0.075 | 0.134 | 0.0141 |
| 30 | 0.0100 | 0.012 | 0.014 | 0.08 | 0.127 | 0.0125 |
| 31 | 0.0089 | 0.01 | 0.0132 | 0.085 | 0.12 | 0.0109 |
| 32 | 0.0080 | 0.009 | 0.0128 | 0.09 | 0.115 | 0.0102 |
| 33 | 0.0071 | 0.008 | 0.0118 | 0.095 | 0.112 | 0.0094 |
| 34 | 0.0063 | 0.007 | 0.0104 | | 0.11 | 0.0086 |
| 35 | 0.0056 | 0.005 | 0.0095 | | 0.108 | 0.0078 |
| 36 | 0.005 | 0.004 | 0.009 | | 0.106 | 0.0070 |
| 37 | 0.0045 | | | | 0.103 | 0.0066 |
| 38 | 0.0040 | | | | 0.101 | 0.0063 |
| 39 | 0.0035 | | | | 0.099 | |
| 40 | 0.0031 | | | | 0.097 | |

* Also called the U.S. Steel Wire Gage



WIRE AND STANDARD GAGES

178, 178M FILLET OR RADIUS GAGES WITH LOCKING DEVICE

1/32-1/2"/1-15MM

These gages are very useful for tool and diemakers, machinists, screw machine operators, patternmakers and other mechanics to lay out and check radii of tools, dies, patterns, etc.

Made in two English and metric sizes as listed below, each gage has leaves for measuring both concave and convex radii, with each leaf stamped with the radius size. Any one of the leaves can be securely locked in position by a locking device. Made of nicely finished, high quality steel.

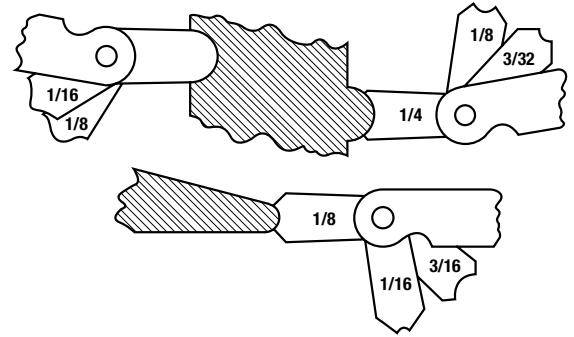

178B

| Inch Reading | | | | |
|--------------------|-------|----------------------------|------------|--------|
| Cat. No. | EDP | Range (Concave and Convex) | Increments | Leaves |
| 178A | 50664 | 1/32-1/4" | 64ths | 30 |
| 178B | 50666 | 17/64-1/2" | | 32 |
| Millimeter Reading | | | | |
| Cat. No. | EDP | Range (Concave and Convex) | Increments | Leaves |
| 178MA | 50665 | 1-3mm | 0.25mm | 34 |
| 178MB | 50667 | 3-7mm | 0.5mm | |

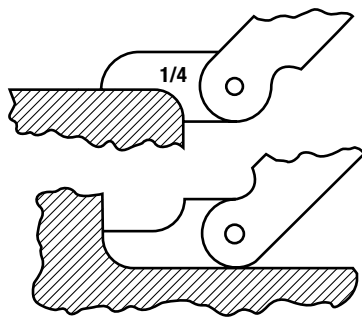

272, 272M FILLET OR RADIUS GAGES

1/32-33/64"/0.75-13MM

An external and internal radius on each leaf permits both concave and convex surfaces to be measured. The leaves are specially shaped for use in any position at any angle to measure fillets and radii in corners or against shoulders. Each leaf is stamped with the radius size and has an eccentric mounting for clearance between the leaf and the case when the gage is opened.



272A

| Inch Reading | | | | |
|--------------------|-------|----------------------------|------------|--------|
| Cat. No. | EDP | Range (Concave and Convex) | Increments | Leaves |
| 272A | 51296 | 1/32-17/64" | 64ths | 16 |
| 272B | 51298 | 9/32-33/64" | | |
| Millimeter Reading | | | | |
| Cat. No. | EDP | Range (Concave and Convex) | Increments | Leaves |
| 272MA | 51297 | 0.75-5mm | 0.25mm | 18 |
| 272MB | 51299 | 5.5-13mm | 0.5mm | 16 |

279 FILLET OR RADIUS GAGES

.020-.4000

This gage is similar to our 272, except that it has twenty leaves with radii from .020-.400" inclusive. Nine leaves have concave and convex radii from .020-.10" in increments of .010", four leaves with concave and convex radii from .125-.20" in increments of .025", one leaf with concave and convex radii of .250", three leaves with concave radii only from .300-.400" in increments of .050" and three leaves with convex radii from .300-.400" by an increment of .050".



279

| Inch Reading | | | |
|--------------|-------|----------------------------|--------|
| Cat. No. | EDP | Range (Concave and Convex) | Leaves |
| 279 | 51314 | .020-.400" | 20 |



ANGLE AND CENTER GAGES

466 ANGLE GAGE

1-45°

A convenient, timesaving tool for inspectors, toolmakers, and diesinkers when checking angles. Tool also replaces a protractor in many instances. The gage has 18 leaves, each with a different angle including 14-1/2° (1/2 the Acme Standard of 29°). Leaves are made of the finest spring-tempered steel and both the angle edge and two sides are ground. Approximately 9/32" thick, 1-1/16" wide and 4-3/16" long.

| 466 Angle Gage | | | | |
|----------------|-------|-------|--------|--|
| Cat. No. | EDP | Range | Leaves | Angles Available |
| 466 | 52463 | 1-45° | 18 | 1°, 2°, 3°, 4°, 5°, 7°, 8°, 9°, 10°, 12°, 14°, 14-1/2°, 15°, 20°, 25°, 30°, 35°, 45° |



466

C391 CENTER GAGE

60° AMERICAN NATIONAL

C396 CENTER GAGE

55° WHITWORTH OR ENGLISH

C398M CENTER GAGE

60° METRIC

- Extremely handy for use in grinding and setting screw cutting tools
- Meets American National or U.S. 60°, Whitworth or English 55°, and Metric 60° standards
- Very useful for finding number of threads per inch through graduations in 14ths, 20ths, 24ths and 32nds of an inch on C391 and C396
- Graduations on C398M are in mm and 1/2mm
- C391 Gage also has a table of double depths of threads for determining size of tap drills
- Made of spring-tempered steel with satin chrome finish
- Ground gaging surfaces

| Center Gages with Inch Graduations | | |
|--|-------|------------------------------------|
| Cat. No. | EDP | Description |
| C391 | 51475 | American National Standard, 60° |
| C396 | 51477 | Whitworth or English Standard, 55° |
| Center Gages with Millimeter Graduations | | |
| Cat. No. | EDP | Description |
| C398M | 51478 | Metric Standard, 60° |

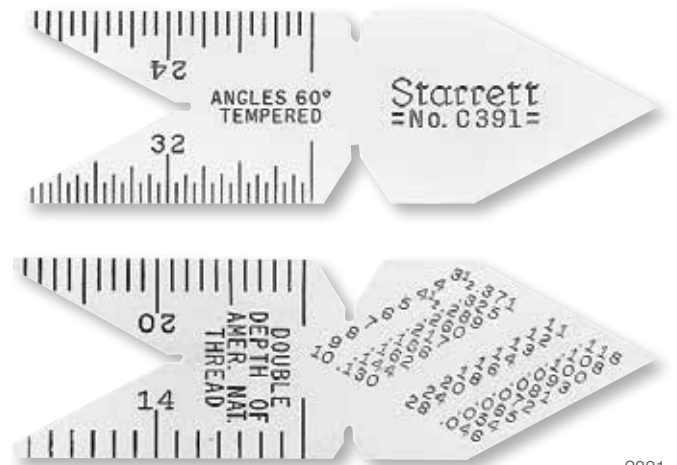

C391



SCREW PITCH GAGES

ENGLISH AND METRIC SCREW PITCH GAGES

2-1/4-84 PITCHES (INCH)

0.25-11.5 PITCHES (MILLIMETER)

Screw pitch gages are among the most useful tools in any mechanics' tool box. They quickly determine the pitch of various threads. These gages consist of a substantial steel case with a number of folding leaves at both ends, each leaf having teeth corresponding to a specific pitch, marked on each leaf.

Starrett screw pitch gages are available in a wide range of sizes with different numbers of leaves in various pitch ranges.

V, Unified, American National 60° threads

Whitworth Standard 55° threads

International Metric Standard 60° threads

English and metric threads are similar in form, but English threads are described in threads per inch and metric threads by the distance from one crest to the next.

All screw pitch gages (except 473 and 476, which have a positive stop design) feature a locking device at both ends of the case, so leaves can be securely locked in position for use. Leaves on most gages have a special narrow design, permitting checking internal threads in nuts, etc., as well as external threads.

Various types of Starrett screw pitch gages are illustrated on the following pages, with complete specifications.

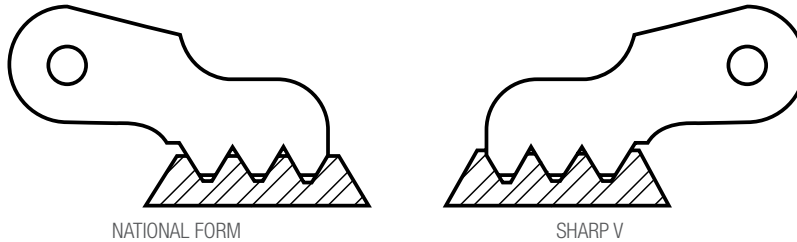

NATIONAL FORM

SHARP V

Starrett Screw Pitch Gages have the tops of the teeth flattened, permitting use of a single gage for either National Form threads or Sharp V threads



155



484



6



474

Screw Pitch Gages

| Cat. No. | EDP | No. of Leaves | TPI Range | Threads per Inch (TPI) | Description |
|----------|-------|---------------|-----------|---|---|
| 155 | 50588 | 27 | 2-1/4-28 | 2-1/4, 2-3/8, 2-1/2, 2-5/8, 2-3/4, 2-7/8, 3, 3-1/4, 3-1/2, 4, 4-1/2, 5, 5-1/2, 6, 7, 8, 9, 10, 11, 12, 13, 14, 16, 18, 20, 24, 28 | With locking device and 60° center gage |
| 484 | 67447 | 28 | 3-1/2-36 | 3-1/2, 4, 4-1/2, 5, 5-1/2, 6, 7, 8, 9, 10, 11, 11-1/2, 12, 13, 14, 15, 16, 18, 20, 22, 24, 26, 27, 28, 30, 32, 34, 36 | With locking device |
| 6 | 50035 | 30 | 4-42 | 4, 4-1/2, 5, 5-1/2, 6, 7, 8, 9, 10, 11, 11-1/2, 12, 13, 14, 15, 16, 18, 20, 22, 24, 26, 27, 28, 30, 32, 34, 36, 38, 40, 42 | With locking device and 11-1/2 and 27 pipe thread pitches |
| 474 | 52486 | 28 | 4-80 | 4, 4-1/2, 5, 6, 7, 8, 9, 10, 11, 11-1/2, 12, 13, 14, 16, 18, 20, 24, 27, 28, 32, 36, 40, 44, 48, 56, 64, 72, 80 | With locking device and 11-1/2 and 27 pipe thread pitches |

FORMULAS

American National V Thread

$$d = D - \frac{1.299}{N} \quad d = D - \frac{1.732}{N}$$

D = Outside diameter of tap

d = Bottom diameter of tap

N = Number of threads per inch

SCREW PITCH GAGES

476 WHITWORTH STANDARD SCREW PITCH GAGES

55° THREADS

3-1/2 - 60 TPI (INCH)

156M, 159M INTERNATIONAL METRIC STANDARD SCREW PITCH GAGES

60° THREADS

| Screw Pitch Gages | | | | | |
|-------------------|-------|---------------|-------------|--|---|
| Cat. No. | EDP | No. of Leaves | TPI Range | Threads per Inch (TPI) | Description |
| 472 | 52484 | 51 | 4-84 | First Corner 17 Leaves: 4, 4-1/2, 5, 5-1/2, 6, 7, 8, 9, 10, 11, 11-1/2, 12, 13, 14, 15, 16, 18 Second Corner 17 Leaves: 20, 22, 24, 26, 27, 28, 30, 32, 34, 36, 38, 40, 42, 44, 46, 48, 50 Third Corner 17 Leaves: 52, 54, 56, 58, 60, 62, 64, 66, 68, 70, 72, 74, 76, 78, 80, 82, 84 | With Locking Device and 11-1/2 and 27 Pipe Thread Pitches |
| 473 | 52485 | 30 | 6-60 | 6, 7, 8, 9, 10, 11, 11-1/2, 12, 13, 14, 15, 16, 18, 20, 22, 24, 26, 27, 28, 30, 32, 34, 36, 38, 40, 42, 48, 50, 56, 60 | With Positive Stop and 11-1/2 and 27 Pipe Thread Pitches |
| 476 | 52488 | 30 | 3-1/2-60 | 3-1/2, 4, 4-1/2, 5, 6, 7, 8, 9, 10, 11, 12, 13, 14, 16, 18, 19, 20, 22, 24, 25, 26, 28, 30, 32, 36, 40, 44, 48, 50, 60 | With Positive Stop |
| 156M | 50589 | 28 | 0.25-2.50mm | 0.25, 0.30, 0.35, 0.40, 0.45, 0.50, 0.55, 0.60, 0.65, 0.70, 0.75, 0.80, 0.85, 0.90, 1, 1.10, 1.20, 1.25, 1.30, 1.40, 1.50, 1.60, 1.70, 1.75, 1.80, 1.90, 2, 2.50 | With Locking Device |
| 159M | 50591 | 28 | 0.5-11.5mm | 0.5, 0.75, 1, 1.10, 1.25, 1.5, 1.75, 2, 2.5, 3, 3.5, 4, 4.5, 5, 5.5, 6, 6.5, 7, 7.5, 8, 8.5, 9, 9.5, 10, 10.5, 11, 11.5 | With Locking Device and 60° Center Gage |



476



473



156M



159M



472



RADIUS GAGES

167, 167M

1/64-1/2"/0.5-15MM

167

.010-.500

110 GAGE HOLDER

S167, S167M SETS

1/64-1/2"/0.5-15MM

SD167 SETS

.010-.500

Radii or fillets can be checked or laid out easier, faster, and more accurately with Starrett 167 Radius Gages. Available individually and in sets, fractional sizes 1/64-1/2", decimal sizes .010-.500" and in millimeters from 0.5-15mm.

Many different sets for maximum convenience. Each set is furnished in an attractive case, providing complete protection and easy, instant selection of the right gage size for the job.

GAGE FEATURES

- Made of satin finish stainless steel – rust and stain resistant
- Each gage is clearly marked with its radius
- Each gage has five different gaging surfaces for both convex and concave radii
- All gages have precision finished radii with extra smooth, accurate edges

GAGE HOLDER FEATURES

- Any gage can be used with the Starrett 110 holder which is especially useful for checking radii in confined or hard-to-reach locations
- Two slots are provided in the holder permitting gages to be held at 30° or 45°, either square in the slot or tipped to one side
- The holder is 4" (100mm) long, providing good reach and balance



Holder 110 with
167-3/16 attached



S167CHZ Radius Gage Set with 25
gages and holder in case

Gaging radii using
gage with holder



FIVE DIFFERENT GAGING SURFACES –

Ideal for Checking Convex and Concave Radii of All Types

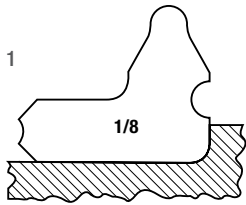

Fig 1. Checking concave (internal) radius with 90° arc. Also checks if sides are tangent to radius and 90° to each other.

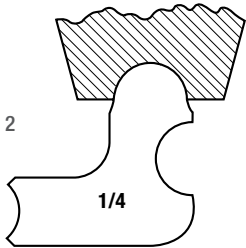

Fig 2. Checking concave (internal) radius with arc up to 180°. Also will check radius shown in Fig. 1 but not relationship of sides.

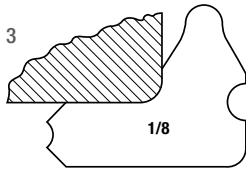

Fig 3. Checking convex (external) radius with 90° arc. Also checks if sides are tangent to radius and 90° to each other.

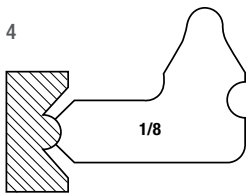

Fig 4. Checking convex (external) radius with arc of 90° or greater, or radii with sides as shown which would interfere with gage used as in Fig. 3.

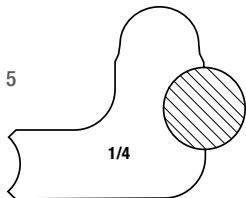

Fig 5. Checking convex (external) radius with arc of 180°; also less than 180° if sides of radius offer no interference.

S167 Radius Gage Sets – Inch

| Cat. No. | EDP | Radii Range | Increments | Gages | Description |
|---------------|-------|--------------------------|----------------|-------|---|
| S167AZ | 50615 | 1/32-17/64" | 64ths | 16 | Without holder |
| S167AHZ | 50616 | 1/64-17/64" | 64ths | 17 | With holder |
| S167BZ | 50617 | 9/32-1/2" | 32nds | 8 | Without holder |
| S167CZ | 50618 | 1/32-17/64" 9/32-1/2" | 64ths 32nds | 24 | Sets 167A and S167B Combined, without holder |
| S167CHZ | 50619 | 1/64-17/64" | 64ths | 25 | Sets 167AH and S167B Combined, with holder |
| S167CHZ W/SLC | 66876 | 9/32-1/2" | 32nds | | Sets 167AH and S167B combined, with holder, Standard Letter of Certification* |
| S167DZ | 50620 | 1/32-1/2" | 32nds | 16 | Without holder |

S167M Radius Gage Sets – Millimeter

| Cat. No. | EDP | Radii Range | Increments | Gages | Description |
|----------|-------|-------------------|--------------|-------|---|
| S167MAZ | 55817 | 1-7mm | 0.5mm | 13 | Without holder |
| S167MAHZ | 55818 | 0.5-7mm | 0.5mm | 14 | With holder |
| S167MBZ | 55819 | 8-15mm | 1mm | 8 | Without holder |
| S167MCZ | 55820 | 1-7mm 8-15mm | 0.5mm 1mm | 21 | Sets S167MA and S167MB combined, without holder |
| S167MCHZ | 55821 | 0.5-7mm 8-15mm | 0.5mm 1mm | 22 | Sets 167MB and S167MAH combined, with holder |
| S167MDZ | 55822 | 1-15mm | 1mm | 15 | Without holder |

SD167 Radius Gage Sets – Decimal-Inch

| Cat. No. | EDP | Radii Range | Increments | Gages | Description |
|----------|-------|-------------|------------|-------|----------------|
| SD167FZ | 63464 | .020-.300 | 0.02 | 19 | Without holder |
| SD167FHZ | 63460 | .350-.500 | 0.05 | | With holder |
| SD167GZ | 63433 | .010-.025 | 0.005 | 26 | Without holder |
| | | .030-.100 | 0.01 | | |
| | | .120-.300 | 0.02 | | |
| SD167GHZ | 63463 | .350-.500 | 0.05 | 26 | With holder |
| | | .010-.025 | 0.005 | | |
| | | .030-.100 | 0.01 | | |
| | | .120-.300 | 0.02 | | |

167 Radius Gage - Accessories

| Cat. No. | EDP | Description |
|----------|-------|-------------|
| 110 | 50475 | Holder only |

* Includes redemption card for Standard Letter of Certification (SLC).

Individual Radius Gage Specifications

| 167 – Inch | | |
|------------|-------|--------|
| Cat. No. | EDP | Radius |
| 167-1/64 | 50646 | 1/64" |
| 167-1/32 | 50622 | 1/32" |
| 167-3/64 | 50623 | 3/64" |
| 167-1/16 | 50624 | 1/16" |
| 167-5/64 | 50625 | 5/64" |
| 167-3/32 | 50626 | 3/32" |
| 167-7/64 | 50627 | 7/64" |
| 167-1/8 | 50628 | 1/8" |
| 167-9/64 | 50629 | 9/64" |
| 167-5/32 | 50630 | 5/32" |
| 167-11/64 | 50631 | 11/64" |
| 167-3/16 | 50632 | 3/16" |
| 167-13/64 | 50633 | 13/64" |
| 167-7/32 | 50634 | 7/32" |
| 167-15/64 | 50635 | 15/64" |
| 167-1/4 | 50636 | 1/4" |
| 167-17/64 | 50637 | 17/64" |
| 167-9/32 | 50638 | 9/32" |
| 167-5/16 | 50639 | 5/16" |
| 167-11/32 | 50640 | 11/32" |
| 167-3/8 | 50641 | 3/8" |
| 167-13/32 | 50642 | 13/32" |
| 167-7/16 | 50643 | 7/16" |
| 167-15/32 | 50644 | 15/32" |
| 167-1/2 | 50645 | 1/2" |

Individual Radius Gage Specifications

| 167M – mm | | |
|------------|-------|--------|
| Cat. No. | EDP | Radius |
| 167M-1/2 | 55795 | 0.5mm |
| 167M-1 | 55796 | 1mm |
| 167M-1 1/2 | 55797 | 1.5mm |
| 167M-2 | 55798 | 2mm |
| 167M-2 1/2 | 55799 | 2.5mm |
| 167M-3 | 55800 | 3mm |
| 167M-3 1/2 | 55801 | 3.5mm |
| 167M-4 | 55802 | 4mm |
| 167M-4 1/2 | 55803 | 4.5mm |
| 167M-5 | 55804 | 5mm |
| 167M-5 1/2 | 55805 | 5.5mm |
| 167M-6 | 55806 | 6mm |
| 167M-6 1/2 | 55807 | 6.5mm |
| 167M-7 | 55808 | 7mm |
| 167M-8 | 55809 | 8mm |
| 167M-9 | 55810 | 9mm |
| 167M-10 | 55811 | 10mm |
| 167M-11 | 55812 | 11mm |
| 167M-12 | 55813 | 12mm |
| 167M-13 | 55814 | 13mm |
| 167M-14 | 55815 | 14mm |
| 167M-15 | 55816 | 15mm |

Individual Radius Gage Specifications

| 167 - Decimal-Inch | | |
|--------------------|-------|--------|
| Cat. No. | EDP | Radius |
| 167-010 | 63434 | 0.01 |
| 167-015 | 63435 | 0.015 |
| 167-020 | 63436 | 0.02 |
| 167-025 | 63437 | 0.025 |
| 167-030 | 63438 | 0.03 |
| 167-040 | 63439 | 0.04 |
| 167-050 | 63440 | 0.05 |
| 167-060 | 63441 | 0.06 |
| 167-070 | 63442 | 0.07 |
| 167-080 | 63443 | 0.08 |
| 167-090 | 63444 | 0.09 |
| 167-100 | 63445 | 0.1 |
| 167-120 | 63446 | 0.12 |
| 167-140 | 63447 | 0.14 |
| 167-160 | 63448 | 0.16 |
| 167-180 | 63449 | 0.18 |
| 167-200 | 63450 | 0.2 |
| 167-220 | 63451 | 0.22 |
| 167-240 | 63452 | 0.24 |
| 167-260 | 63453 | 0.26 |
| 167-280 | 63454 | 0.28 |
| 167-300 | 63455 | 0.3 |
| 167-350 | 63456 | 0.35 |
| 167-400 | 63457 | 0.4 |
| 167-450 | 63458 | 0.45 |
| 167-500 | 63459 | 0.5 |



THICKNESS GAGES

ENGLISH AND METRIC THICKNESS GAGES

.0015-.200"/0.03-5MM

These gages are used in automotive, aviation, diesel, food and agricultural industries. They're also used in jig, fixture, gage and experimental work. In automotive, they are especially useful when adjusting tappets, spark plugs, distributor points, checking bearing clearances and gear play, fitting pistons, rings and pins and gaging narrow slots. Made in a wide range of types and sizes, each having from 6 up to 26 leaves ranging in thickness from .0015-.200" and 0.03-5mm thick, straight or tapered.

- Now available in stainless and tempered steel
- Leaves carefully finished to correct thickness, individually tested and marked with thickness
- Locking device on most gages permits securely locking of one or more leaves in position
- Leaves are easily removed or replaced
- Rugged, substantial steel case protect leaves
- All include locking device

| Inch Reading Thickness Gages with Straight Leaves | | | | | | |
|---|-------|-----------------|-------|---------------|---------------|---|
| Tempered Steel | | Stainless Steel | | No. of Leaves | Size Leaves | Range Leaf Thickness (in) |
| Cat. No. | EDP | Cat. No. | EDP | | | |
| 172A | 50649 | 172AS | 50649 | 9 | 1/2 x 3-1/32" | .0015, .002, .003, .004, .006, .008, .010, .012, .015 |
| 66 | 50314 | 66S | 73466 | 26 | 1/2 x 3-1/32" | .0015, .002, .0025, .003, .004, .005, .006, .007, .008, .009, .010, .011, .012, .013, .014, .015, .016, .017, .018, .019, .020, .021, .022, .023, .024, .025 |
| 66B | 57097 | 66BS | 73439 | 31 | 1/2 x 3-1/32" | .0015, .002, .0025, .003, .004, .005, .006, .007, .008, .009, .010, .011, .012, .013, .014, .015, .016, .017, .018, .019, .020, .021, .022, .023, .024, .025, .026, .028, .030, .032, .035 |
| 467 | 52464 | 467S | 73340 | 13 | 1/2 x 4-1/2" | .0015, .002, .003, .004, .006, .008, .010, .020, .030, .040, .075, .100, .200 |
| 172E | 50654 | 172ES | 73343 | 8 | 1/2 x 12" | .002, .003, .004, .005, .006, .008, .010, .015 |
| 572A | 57098 | | | 22 | 1/2 x 3-1/32" | .0015, .002, .0025, .003, .004, .005, .006, .007, .008, .009, .010, .012, .013, .014, .015, .016, .018, .020, .022, .025, .030, .035 6 Spark Plug Wire Gages: .025, .030, .034, .035, .040, .045 |
| 572B | 57099 | | | 22 | 1/2 x 3-1/32" | .0015, .002, .0025, .003, .004, .005, .006, .007, .008, .009, .010, .012, .013, .014, .015, .016, .018, .020, .022, .025, .030, .035 |

| Inch Reading Thickness Gages with Tapered Leaves | | | | | | |
|--|-------|-----------------|-------|---------------|-------------------|--|
| Tempered Steel | | Stainless Steel | | No. of Leaves | Size Leaves | Range Leaf Thickness (in) |
| Cat. No. | EDP | Cat. No. | EDP | | | |
| 66T | 50315 | 66TS | 73442 | 26 | 1/2-1/4 x 3-1/32" | .0015, .002, .0025, .003, .004, .005, .006, .007, .008, .009, .010, .011, .012, .013, .014, .015, .016, .017, .018, .019, .020, .021, .022, .023, .024, .025 |
| 172AT | 50650 | 172ATS | 73342 | 9 | 1/2-1/4 x 3-1/32" | .0015, .002, .003, .004, .006, .008, .010, .012, .015 |
| 172CT | 50652 | | | 8 | 1/2-1/4 x 6" | .002, .003, .004, .006, .008, .010, .012, .015 |

| Millimeter Reading Thickness Gages with Straight Leaves | | | | |
|---|-------|---------------|--------------|---|
| Tempered Steel | | No. of Leaves | Size Leaves | Range Leaf Thickness (in) |
| Cat. No. | EDP | | | |
| 66MA | 55974 | 20 | 12.7 x 77mm | 0.05, 0.10, 0.15, 0.20, 0.25, 0.30, 0.35, 0.40, 0.45, 0.50, 0.55, 0.60, 0.65, 0.70, 0.75, 0.80, 0.85, 0.90, 0.95, 1.0 |
| 173MA | 57086 | 13 | 12.7 x 77mm | 0.03, 0.04, 0.05, 0.06, 0.07, 0.08, 0.09, 0.10, 0.15, 0.20, 0.30, 0.40, 0.50 |
| 467M | 52465 | 13 | 12.7 x 114mm | 0.04, 0.05, 0.06, 0.07, 0.08, 0.10, 0.15, 0.20, 0.30, 1.0, 2.0, 3.0, 5.0 |

| Millimeter Reading Thickness Gages with Tapered Leaves | | | | |
|--|-------|---------------|----------------|--|
| Tempered Steel | | No. of Leaves | Size Leaves | Range Leaf Thickness (in) |
| Cat. No. | EDP | | | |
| 172MBT | 50656 | 9 | 12.7-7 x 114mm | 0.04, 0.05, 0.06, 0.07, 0.08, 0.10, 0.15, 0.20, 0.30 |
| 173MAT | 57087 | 13 | 12.7-7 x 77mm | 0.03, 0.04, 0.05, 0.06, 0.07, 0.08, 0.09, 0.10, 0.15, 0.20, 0.30, 0.40, 0.50 |
| 173MCT | 57088 | 13 | 12.7-7 x 152mm | 0.03, 0.04, 0.05, 0.06, 0.07, 0.08, 0.09, 0.10, 0.15, 0.20, 0.30, 0.40, 0.50 |

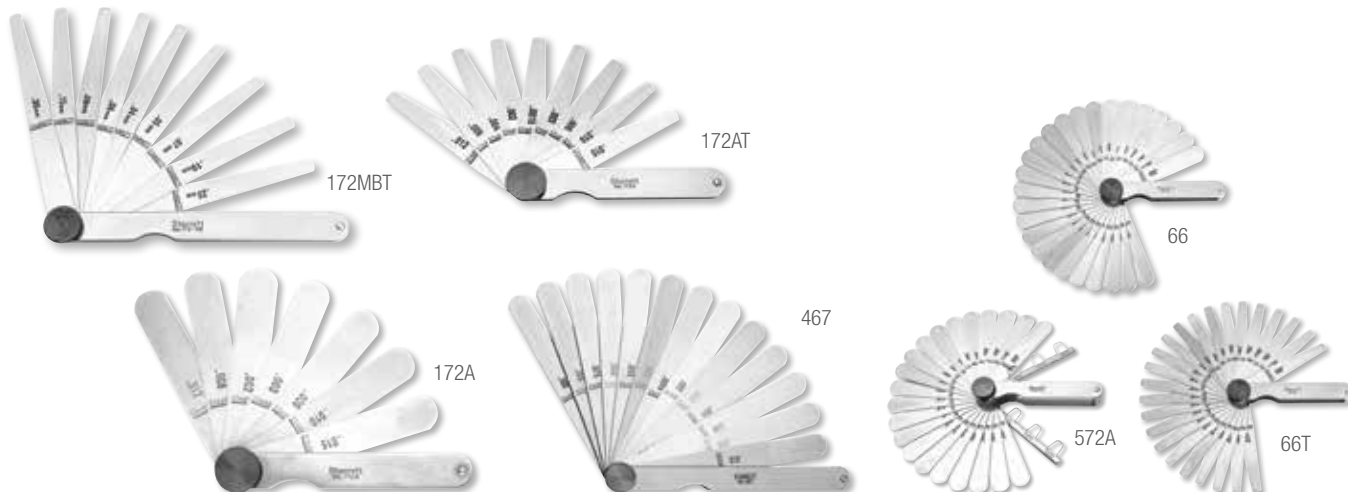

"FEELER" STOCK

666 THICKNESS GAGE OR "FEELER" STOCK IN ROLLS

25' DISPENSER CASES .001-.015"

20', 25' CARDBOARD BOXES .0005-.025"

666M THICKNESS GAGE OR "FEELER" STOCK IN ROLLS

7.6M DISPENSER CASES 0.03-0.35MM

6.1M CARDBOARD BOXES 0.40-0.50MM

This handy product includes thickness stock, housed in convenient rewindable dispenser rolls. Having the thickness stock in a case makes it very useful for cutting off the required length for adjusting tappets, spark plugs, distributor points, checking bearing clearances and gear play, fitting pistons, rings and pins, gaging narrow slots, etc. This stock is also useful for shimming in fixturing and die work.

- Now available in stainless and tempered steel
- Handy 25' and 7.6m rolls 1/2" and 12.7mm wide, in a compact, sturdy plastic rewindable dispenser case. This case handles stock up to .015" and 0.35mm only.
- Rewind feature permits retracting thinner feeler stock into the case, preventing damage
- Roll stock in thicknesses of .016" or 0.40mm and over are furnished in 20' or 6m (nondispensable) rolls in a cardboard box. Also, the .0005", 25' size is furnished in a cardboard box.
- Marked every 6" or 150mm with a line, thickness in thousandths of an inch or in hundredths of a mm (exception 666-1/2)
- Case provides the ability to snip off the desired length without any waste



| Inch Reading Rolls – Dispenser Case | | | | | |
|---|-------|-----------------|--------|-----------|--------|
| Tempered Steel | | Stainless Steel | | Thickness | Length |
| Cat. No. | EDP | Cat. No. | EDP | | |
| 666-1 | 52796 | 666S-1 | 73350 | .001" | 25' |
| 666-1 1/2 | 52797 | 666S-1 1/2 | 73351 | .0015" | |
| 666-2 | 52798 | 666S-2 | 73363 | .002" | |
| 666-2 1/2 | 52799 | 666S-2 1/2 | 73364 | .0025" | |
| 666-3 | 52800 | 666S-3 | 73371 | .003" | |
| 666-4 | 52801 | 666S-4 | 73372 | .004" | |
| 666-5 | 52802 | 666S-5 | 73373 | .005" | |
| 666-6 | 52803 | 666S-6 | 73374 | .006" | |
| 666-7 | 52804 | 666S-7 | 73375 | .007" | |
| 666-8 | 52805 | 666S-8 | 73376 | .008" | |
| 666-9 | 52806 | 666S-9 | 73377 | .009" | |
| 666-10 | 52807 | 666S-10 | 73353 | .010" | |
| 666-11 | 52808 | 666S-11 | 73354 | .011" | |
| 666-12 | 52809 | 666S-12 | 73355 | .012" | |
| 666-13 | 52810 | 666S-13 | 73356 | .013" | |
| 666-14 | 52811 | 666S-14 | 73357 | .014" | |
| 666-15 | 52812 | 666S-15 | 73358 | .015" | |
| Inch Reading Rolls – Cardboard Box | | | | | |
| Tempered Steel | | Stainless Steel | | Thickness | Length |
| Cat. No. | EDP | Cat. No. | EDP | | |
| 666-1/2 | 64210 | 666S-1/2 | 73352 | .0005" | 25' |
| 666-16 | 52813 | 666S-16 | 73359 | .016" | 20' |
| 666-17 | 52814 | 666S-17 | 63370 | .017" | |
| 666-18 | 52815 | 666S-18 | 73361 | .018" | |
| 666-19 | 52816 | 666S-19 | 73362 | .019" | |
| 666-20 | 52817 | 666S-20 | 73365 | .020" | |
| 666-21 | 52818 | 666S-21 | 73366 | .021" | |
| 666-22 | 52819 | 666S-22 | 73367 | .022" | |
| 666-23 | 52820 | 666S-23 | 73368 | .023" | |
| 666-24 | 52821 | 666S-24 | 73369 | .024" | |
| 666-25 | 52822 | 666S-25 | 73370 | .025" | |
| Millimeter Reading Rolls – Dispenser Case | | | | | |
| Tempered Steel | | Thickness | Length | | |
| Cat. No. | EDP | | | | |
| 666M-3 | 52823 | 0.03mm | 7.6m | | |
| 666M-4 | 52824 | 0.04 mm | | | |
| 666M-5 | 52825 | 0.05mm | | | |
| 666M-6 | 52826 | 0.06mm | | | |
| 666M-8 | 52827 | 0.08mm | | | |
| 666M-10 | 52828 | 0.10mm | | | |
| 666M-15 | 52829 | 0.15mm | | | |
| 666M-20 | 52830 | 0.20mm | | | |
| 666M-25 | 52831 | 0.25mm | | | |
| 666M-30 | 52832 | 0.30mm | | | |
| 666M-35 | 52833 | 0.35mm | | | |
| Millimeter Reading Rolls – Cardboard Box | | | | | |
| Tempered Steel | | Thickness | Length | | |
| Cat. No. | EDP | | | | |
| 666M-40 | 52834 | 0.40mm | 6.1m | | |
| 666M-45 | 52835 | 0.45mm | | | |
| 666M-50 | 52836 | 0.50mm | | | |

NEW!

FIXED GAGE STANDARDS



NEW!

FIXED GAGE STANDARDS

"FEELER" STOCK

667 THICKNESS GAGES OR "FEELER" STOCK

.0005-.030"

667M THICKNESS GAGES OR "FEELER" STOCK

0.03-0.50MM

These gages are widely used in automotive, aviation, diesel and farm equipment manufacture and service and also in jig, fixture, gage and experimental work.

- Now available in stainless and tempered steel
- Inch sizes are 12" long, 1/2" wide and furnished in 33 different thicknesses ranging from .0005-.030"
- Millimeter sizes are furnished in 300mm lengths, 12.7mm wide in 14 different thicknesses ranging from 0.03-0.50mm
- Rounded ends make stock easier to work with
- Made of the finest tempered steel and stainless steel
- Each piece marked every 6" with thickness (exception 667-1/2) and in individual envelope
- With convenient 3/16" (5mm) hole punched in the end for hanging

| Millimeter Gages – 300mm | | |
|--------------------------|-------|-----------|
| Cat. No. | EDP | Thickness |
| 667M-3 | 52869 | 0.03mm |
| 667M-4 | 52870 | 0.04mm |
| 667M-5 | 52871 | 0.05mm |
| 667M-6 | 52872 | 0.06mm |
| 667M-8 | 52873 | 0.08mm |
| 667M-10 | 52874 | 0.10mm |
| 667M-15 | 52875 | 0.15mm |
| 667M-20 | 52876 | 0.20mm |
| 667M-25 | 52877 | 0.25mm |
| 667M-30 | 52878 | 0.30mm |
| 667M-35 | 52879 | 0.35mm |
| 667M-40 | 52880 | 0.40mm |
| 667M-45 | 52881 | 0.45mm |
| 667M-50 | 52882 | 0.50mm |

| Inch Gages – 12" | | | | |
|------------------|-------|-----------------|-------|-----------|
| Tempered Steel | | Stainless Steel | | |
| Cat. No. | EDP | Cat. No. | EDP | Thickness |
| 667-1/2 | 64209 | 667S-1/2 | 73394 | .0005" |
| 667-1 | 52837 | 667S-1 | 73392 | .001" |
| 667-1 1/2 | 52838 | 667S-1 1/2 | 73393 | .0015" |
| 667-2 | 52839 | 667S-2 | 73405 | .002" |
| 667-2 1/2 | 52840 | 667S-2 1/2 | 43706 | .0025" |
| 667-3 | 52841 | 667S-3 | 73417 | .003" |
| 667-4 | 52842 | 667S-4 | 73419 | .004" |
| 667-5 | 52843 | 667S-5 | 73420 | .005" |
| 667-6 | 52844 | 667S-6 | 73421 | .006" |
| 667-7 | 52845 | 667S-7 | 73422 | .007" |
| 667-8 | 52846 | 667S-8 | 73423 | .008" |
| 667-9 | 52847 | 667-9 | 73424 | .009" |
| 667-10 | 52848 | 667S-10 | 73395 | .010" |
| 667-11 | 52849 | 667S-11 | 73396 | .011" |
| 667-12 | 52850 | 667S-12 | 73397 | .012" |
| 667-13 | 52851 | 667S-13 | 73398 | .013" |
| 667-14 | 52852 | 667S-14 | 73399 | .014" |
| 667-15 | 52853 | 667S-15 | 73400 | .015" |
| 667-16 | 52854 | 667S-16 | 73401 | .016" |
| 667-17 | 52855 | 667S-17 | 73402 | .017" |
| 667-18 | 52856 | 667S-18 | 73403 | .018" |
| 667-19 | 52857 | 667S-19 | 73404 | .019" |
| 667-20 | 52858 | 667S-20 | 73407 | .020" |
| 667-21 | 52859 | 667S-21 | 73408 | .021" |
| 667-22 | 52860 | 667S-22 | 73409 | .022" |
| 667-23 | 52861 | 667S-23 | 73410 | .023" |
| 667-24 | 52862 | 667S-24 | 73411 | .024" |
| 667-25 | 52863 | 667S-25 | 73412 | .025" |
| 667-26 | 52864 | 667S-26 | 73413 | .026" |
| 667-27 | 52865 | 667S-27 | 73414 | .027" |
| 667-28 | 52866 | 667S-28 | 73415 | .028" |
| 667-29 | 52867 | 667S-29 | 73416 | .029" |
| 667-30 | 52868 | 667S-30 | 73418 | .030" |



667

THICKNESS GAGE OR "FEELER" STOCK ASSORTMENTS

Two complete, handy thickness gage assortments:

S667A (Inch) set consists of one each of 32 different pieces, 1/2" x 12" long from .001" through .030" thick (the entire individual range, with exception of the .0005" thickness, as listed on previous page).

S667MA (Millimeter) set consists of one each of 14 different pieces, 12.5mm x 300mm long from 0.03mm through 0.50mm thick (complete range, as on previous page).

S667D Bulk inch-reading assortment consists of 108 pieces, 1/2" x 12", in nine different thicknesses from .0015" to .015" thick. Twelve pieces of a size are packed in a box and each piece in an individual envelope. The nine boxes, together with an extra box for holding odd pieces, are packed in a convenient storage carton.



| Individual Assortments | | | | |
|------------------------|-------|-----------------|-------|---|
| Tempered Steel | | Stainless Steel | | Description |
| Cat. No. | EDP | Cat. No. | EDP | |
| S667A | 63274 | S667AS | 73443 | Complete Starrett inch thickness gage assortment – One each, 32 different sizes |
| S667MA | 64949 | | | Complete Starrett millimeter thickness gage assortment – One each, 14 different sizes |
| Bulk Assortment | | | | |
| Tempered Steel | | Stainless Steel | | Description |
| Cat. No. | EDP | Cat. No. | EDP | |
| S667D | 52883 | S667DS | 73444 | Bulk quantity assortment: 108 pieces in nine thickness sizes; 12 pieces of a size per box; .0015, .002, .003, .004, .006, .008, .010, .012, .015" |

Packed 12 pieces of a size in a box; each piece in individual envelope; 9 boxes in a carton.



THICKNESS GAGES

806 THICKNESS GAGE OR "FEELER" STOCK HOLDERS

CLAMP AT ONE END

806D THICKNESS GAGE OR "FEELER" STOCK HOLDERS

CLAMP AT BOTH ENDS

These 806 Thickness Gage Holders provide a handy, convenient means of rigidly holding single leaves or strips of thickness gage stock of any thickness from .001-.025" (0.03-0.5mm).

Stock up to 6" (150mm) long is easily inserted in the holder and firmly gripped in the desired position by a cam lock. This permits all of the stock to be used, because as it wears from use, the defective end can be snipped off and new stock pulled out until entirely used up.

Available in two types as listed in the chart on the right, either to clamp stock at one end or both ends. Dull nickel finish. Size approximately 3/32" thick x 9/16" wide x 5-1/4" long (2.4 x 14 x 130mm). 806D holders have contrasting finish to eliminate the possible confusion on which end holds the thicker or thinner stock.

| Thickness Gage or "Feeler" Stock Holders | | |
|--|-------|---|
| Cat. No. | EDP | Description |
| 806 | 53039 | Holder only - Clamps stock at one end |
| 806D | 53040 | Holder only - Clamps stock at both ends |



806 with stock clamped on one end



806D with stock clamped on both ends

245, 245M ENGINEERS' COMBINATION TAPER, WIRE AND THICKNESS GAGE

INCH/MILLIMETER

Consists of a wire gage, a taper gage for measuring slot widths, and an assortment of thickness gage leaves, all folding within a compact steel case. The gage measures 1/2" wide x 4-3/4" long (12.7 x 120mm) and has a locking device to lock any leaf or leaves in position.

Both 245 and 245M have an English Standard wire gage leaf similar to our 188, but with shorter range, sizes numbered from 19-36 (.042-.004"), plus two additional sizes, 1/16" and 1/8". The reverse side has decimal equivalents in thousandths.

245 has a taper gage leaf for measuring slot widths from 1/64-3/16" in 64ths of an inch, the reverse side having a 3" scale graduated in 8ths and 16ths. It has nine thickness or feeler leaves as follows: .002, .003, .004, .006, .008, .010, .012, .015 and 1/16".

245M has a taper gage leaf for measuring slot widths from 0.5-5mm in 0.5mm, the reverse side having an 80mm scale graduated in mm and 1/2mm. It has eleven thickness or feeler leaves as follows: 0.04, 0.05, 0.06, 0.07, 0.08, 0.10, 0.15, 0.20, 0.30, 1 and 2mm.



| Inch Reading | | |
|--------------------|-------|--|
| Cat. No. | EDP | Description |
| 245 | 51170 | With taper gage, English standard wire gage and 9 Inch reading thickness gage leaves |
| Millimeter Reading | | |
| Cat. No. | EDP | Description |
| 245M | 51171 | With taper gage, English standard wire gage and 11 mm reading thickness gage leaves |



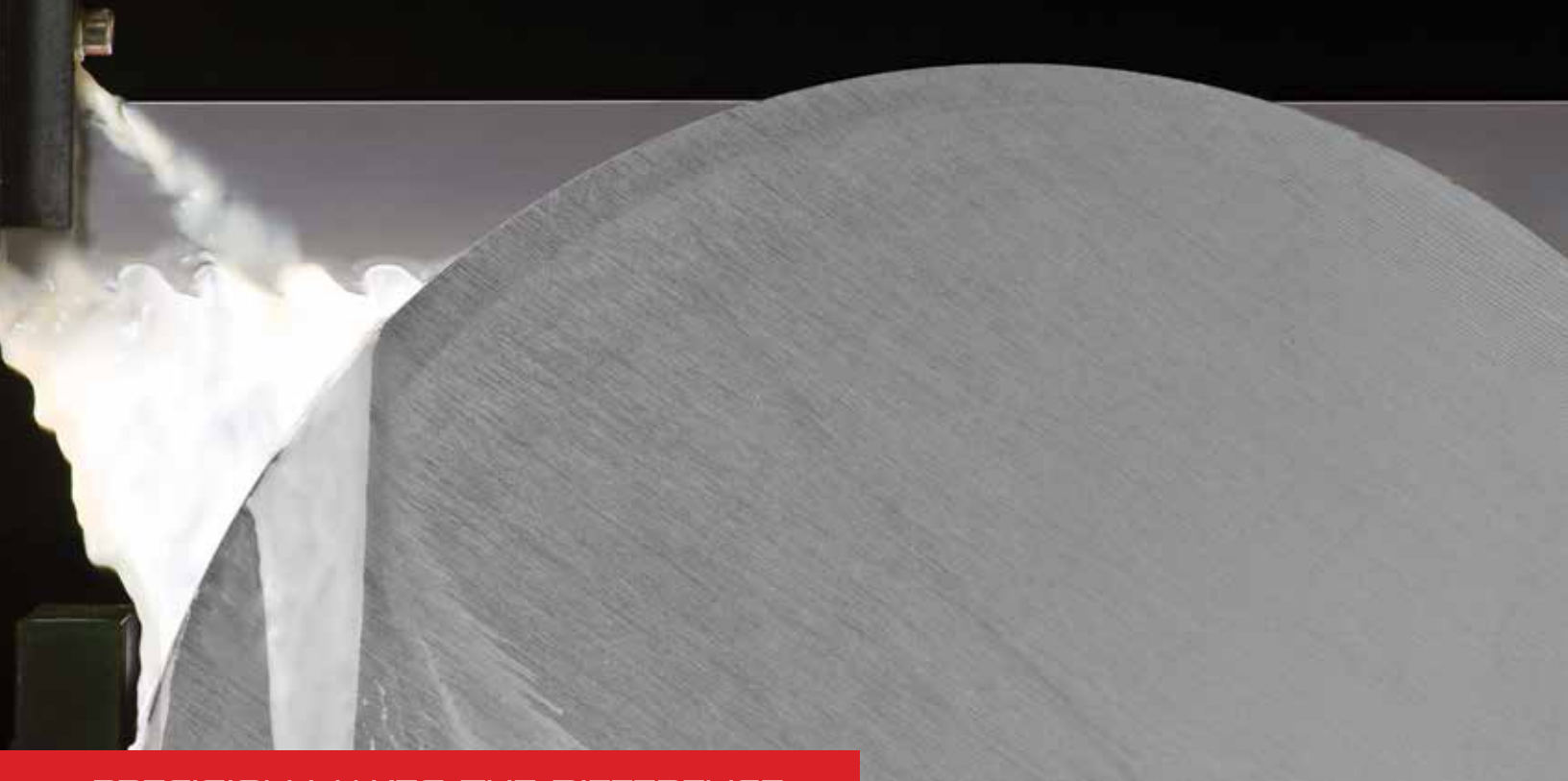

PRECISION MAKES THE DIFFERENCE

HIGH PRODUCTIVITY AND LONGER LIFE

For cutting hard materials!

The Advanz™ MC5 utilizes a multiple chip grind with a high/low tooth sequence. The chip load is spread out over more teeth to facilitate longer life.

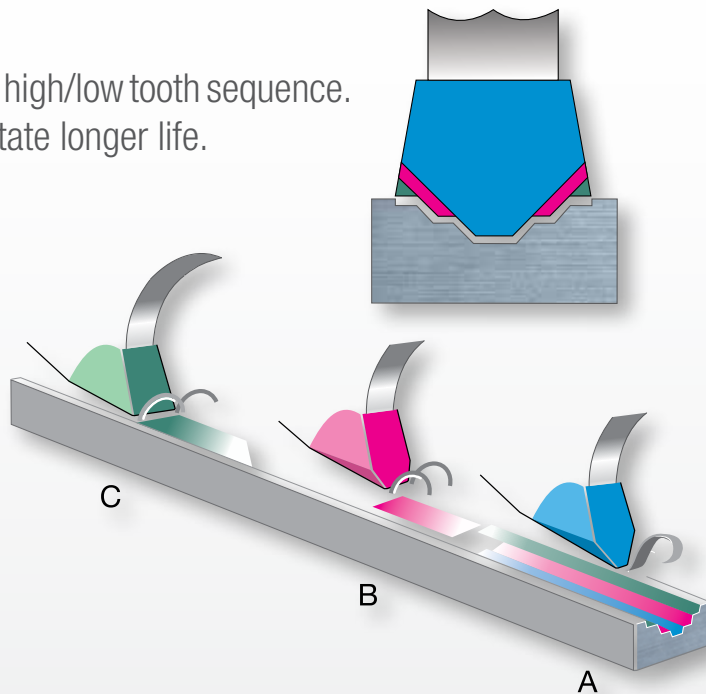

Starrett®

(978) 249-3551 • starrett.com

Follow us!





PRECISION SHOP TOOLS

SURFACE GAGES

56 SMALL SURFACE GAGES

(HARDENED STEEL BASE)

- Smaller base and spindle than other surface gages and is designed for lighter work
- Two frictionally held gage pins in the hardened steel base which can be pushed down and used against the edge of a surface plate or T-slot for linear work
- Weighs only ten ounces (0.28kg.) and takes up very little space in a toolbox
- Only 1-3/8" (35mm) high, including the lower sleeve in the rocker arm
- Scriber has a 3/32" (2.4mm) diameter and is 3-1/4" (82mm) long



| 56 Small Surface Gages | | | | | |
|------------------------|-------|--------------|-------------|-----------|---------|
| Cat. No. | EDP | Spindle | | Base | |
| | | in | mm | in | mm |
| 56A | 50289 | 4 | 100 | 2 x 1-1/2 | 50 x 38 |
| 56B | 50290 | Two, 4 and 7 | 100 and 175 | | |
| 56C | 50291 | 7 | 175 | | |

57 FULL-SIZED SURFACE GAGES

(CAST IRON BASE)

- Full-size surface gage with attractive finish
- Base is ground flat with two frictionally held gage pins that can be pushed down and referenced against the edge of a surface plate or T-slot for linear work

257 FULL-SIZED SURFACE GAGES

(HARDENED STEEL BASE)

- Finest full-size surface gage
- Stable steel base is fully hardened, ground and nicely finished
- Four frictionally held gage pins that add versatility for referencing the tool

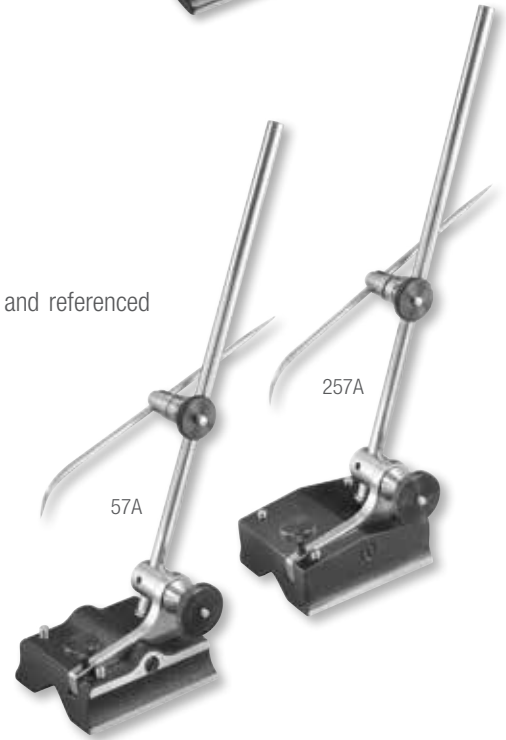

| 57 Full-sized Surface Gages | | | |
|-----------------------------|-------|-----------------------------|----------------------------|
| Cat. No. | EDP | Spindle Length | Base - Length x Width |
| 57A | 50292 | 9" (225mm) | 3 x 2-9/16" (75 x 65mm) |
| 57B | 50293 | 9" and 12" (225 and 300mm) | |
| 57C | 50294 | 12" (300mm) | 3-3/4 x 3-3/8" (95 x 85mm) |
| 57D | 50295 | 12" and 18" (300 and 450mm) | |

| 257 Full-sized Surface Gages | | | |
|------------------------------|-------|-----------------------------|-----------------------------|
| Cat. No. | EDP | Spindle Length | Base - Length x Width |
| 257A | 51240 | 9" (225mm) | 2-7/8 x 2-3/8" (72 x 60mm) |
| 257B | 51241 | 9" and 12" (225 and 300mm) | |
| 257C | 51242 | 12" (300mm) | 3-1/2 x 3-3/16" (90 x 80mm) |
| 257D | 51243 | 12" and 18" (300 and 450mm) | |

| Spindles, Scribers and Standard Snugs for 57 and 257 Surface Gages | | | |
|--|---|---------------------------|---|
| Fits | Spindles | Scribers | Standard Snugs* |
| A and B Models | 5/16 x 9" and 12" (8 x 225mm and 300mm) | 9/64 x 6" (3.6 x 150mm) | PT18718 (EDP 50709) with 5/16" post hole† |
| C and D Models | 3/8 x 12" and 18" (9.5 x 300mm and 450mm) | 5/32 x 8-1/2" (4 x 216mm) | PT18724 (EDP 50710) with 3/8" (9.5mm) post hole |

† For snug with 8mm post hole diameter, order PT27171, EDP 66457.

* Will hold scribers, rods or indicator stems ranging from 3/32-1/4" (2.4-6.35mm) and allows use with these test indicators: 196, 651, 711**, 564**, 708**, 811**, 650, 709**

** Snugs must be used with the proper indicator holder.



SURFACE GAGES

57S, 58S UNIVERSAL SNUGS FOR SURFACE GAGES, INDICATORS AND ACCESSORIES

- Convenient attachment of scribers and test indicator shanks to surface gage magnetic bases, indicator tool post holders and gage rods
- Fits all 57 and 257 Surface Gages and test indicator clamps and post holders
- Permits the use of all of our test indicators: 196, 564*, 650, 651, 708*, 709*, 711 and 811*. (*Snugs must be used with the proper indicator holder)

Universal Snugs for Surface Gages

| Cat. No. | EDP | Spindle Hole Diameters | | Gripping Hole Diameters | |
|----------|-------|------------------------|--------------|-------------------------|---------------------|
| | | in | mm | in | mm |
| 57S | 50296 | 5/16, 3/8 | 8, 9.5 | 9/64, 5/32, 3/16, 1/4 | 3.5, 4, 4.8, 6.35 |
| 58S | 56613 | 1/4, 5/16, 3/8 | 6.35, 8, 9.5 | Range from 3/32-1/4 | Range from 2.4-6.35 |



SURFACE GAGES

Surface Gages are designed for a wide variety of uses. This is a basic tool for machinists and toolmakers. The main uses are for accurately scribing lines, transferring measurements and for probing surfaces in inspection work.

Lines can be scribed to heights and depths. Lines can also be scribed on horizontal surfaces referenced from gage pins on the tool.

Scribers are usually set in relation to rule graduations (our 62 Rule Holder is valuable in this respect) or height gages.

Marrying one of these tools with one of our test indicators makes easy work of checking flatness, parallelism, height and depth.



SCRIBERS

29 SCRATCH GAGE

This tool is extremely useful for scribing lines parallel to a given surface. It is made of steel and the head is hardened. The gage is securely locked by a knurled clamp screw and split bushing in the head.

The marker is a square piece of thin tempered-steel firmly held against the edge of the beam by a screw. The beam is graduated a full 6" by 64ths of an inch, and fine adjustments may be made by a slight rotating movement of the head.

| | | | |
|-----|-------|------------|-------|
| 29B | 50201 | 6" (150mm) | 64ths |
|-----|-------|------------|-------|



29B Scratch Gage

70 POCKET SCRIBERS

CARBIDE OR HARDENED STEEL POINTS

The handle is made of steel, knurled and nickel plated. The scriber point is steel, properly hardened and finely tapered so the location of the point is not obscured.

The scriber is held firmly in the handle by a knurled chuck and when not in use can be reversed, telescoped into the handle, and locked by the chuck. The hexagon-shaped head prevents rolling.

67 IMPROVED SCRIBER

Scribers are steel, properly tempered and well finished. The points are finely tapered so that the scriber point can be easily seen on the work. The handle, as well as the points, have a knurled grip.

The long bent point is useful for reaching through holes. The length of the scriber with the short point is 9" (225mm) and with the long bent point, 12" (300mm). Points screw into the handle and fit either end. The knurled handle is nickel-plated.

68 ADJUSTABLE SLEEVE SCRIBER

A very handy scriber with a point 8" (200mm) in length that is held by an adjustable knurled sleeve. The adjustable sleeve may be clamped close to or away from the working point.

The sleeve is nickel-plated. Available with or without knife point.

70 Pocket Scribers

| Cat. No. | EDP | Point | Point Length | | Handle Diameter | |
|----------|-------|---------|--------------|----|-----------------|-----|
| | | | in | mm | in | mm |
| 70A | 50323 | Steel | 2-3/8 | 60 | 1/4 | 6.4 |
| 70B | 50324 | | 2-7/8 | 72 | 3/8 | 9.5 |
| 70AX | 50327 | Carbide | 2-3/8 | 60 | 1/4 | 6.4 |
| 70BX | 56092 | | 2-7/8 | 72 | 3/8 | 9.5 |

Points Only for 70 Pocket Scribers

| Part No. | EDP | Point | For Starrett Scriber No. |
|----------|-------|---------|--------------------------|
| PT02355A | 70332 | Steel | 70A |
| PT02355B | 70333 | | 70B |
| PT14398 | 71527 | Carbide | 70AX |
| PT19306 | 72049 | | 70BX |

67 Improved Scribers

| Catalog | EDP | Description |
|---------|-------|--|
| 67A | 50316 | Complete with 3 points (1 straight, 1 short bent, 1 long bent) |
| 67B | 50317 | With 2 points (1 straight, 1 short bent) |

Points Only for 67 Improved Scribers

| Part | EDP | Description |
|---------|-------|------------------------|
| PT16584 | 71555 | Extra straight point |
| PT16585 | 71556 | Extra short bent point |
| PT16586 | 71557 | Extra long bent point |

68 Adjustable Sleeve Scribers

| Cat. No. | EDP | Description |
|----------|-------|---------------------|
| 68A | 50322 | With knife point |
| 68B | 50321 | Without knife point |



70A, 67A, 68A Scribers



PRECISION SHOP TOOLS

1610 KLEENScribe™ LAYOUT DYE

- Deep blue, quick-drying dye for clean, dry metal surfaces
- Brush or spray an opaque blue background that makes scribed lines stand out sharp and clear
- Will not rub off on hands or clothing or flake away
- Unaffected by cutting lubricants and heat generated during machining
- To remove, use a rag or wiper, moistened with denatured alcohol

IDEAL FOR NUMEROUS APPLICATIONS:

- Laying out dies, cams, templates, jigs, fixtures, patterns, castings
- Touching cutting tool to work before setting machine for cut
- Identifying tools, parts, bar stock and other shop metals
- Checking alignment of gears and wearing parts



| Kleenscribe™ Layout Dye | | | |
|-------------------------|-------|------------------------|----------------|
| Cat. No. | EDP | Size | Description |
| 1610-4 | 53212 | 4oz. (0.1 liter) | Plastic Bottle |
| 1610-16 | 53213 | 16 oz. (0.5 liter) | Plastic Bottle |
| 1610-32 | 53214 | 32 oz. (1 liter) | Plastic Bottle |
| 1611 | 55896 | 11-1/2 oz. (0.3 liter) | Aerosol Can |

1 ADJUSTABLE-JAW CUT NIPPERS

Special design provides powerful leverage for efficient and clean cutting. Especially recommended for all applications involving wire cutting. These tools can be adjusted for wider jaw openings to easily cut tile and mosaics.

- Heat-treated steel frames for strength
- Carbide jaws for extra long life
- Red vinyl coated handles for a firm, comfortable grip
- Jaws can be detached and replaced, or resharpened. Jaws should be ground in pairs and referenced from the serrations
- Jaws can be adjusted on the frames. Each jaw has an allowance of about 1/4" (6.4mm) to cut tile or to adjust after resharpening.
- Stud and stop screw on the handle can be adjusted for proper jaw closure, thereby preventing damage from excess pressure on the jaws
- A flat safety spring below the cutting edges of the jaws forms a yielding seat for the end of the wire to press against while being cut



| 1 Adjustable-Jaw Cut Nippers | | | | | | | | | | |
|------------------------------|-------|------------------|-------|-------|-----|---------------------------|-----|-----------|------|----------------|
| Cat. No. | EDP | Jaws Only (Pair) | | Size | | Capacity (Max. Wire Dia.) | | Jaw Width | | Jaws |
| | | Part No. | EDP | in | mm | in | mm | in | mm | |
| 1X-5 1/2 | 50004 | PT01931-1 | 50006 | 5-1/2 | 138 | .050 | 1.3 | 21/32 | 16.5 | Carbide Tipped |
| 1X-7 | 50005 | PT01932-1 | 50007 | 7 | 175 | .080 | 2 | 13/16 | 21 | Carbide Tipped |



PRECISION SHOP TOOLS

WIGGLER OR CENTER FINDER WITH ATTACHMENTS 828

Wiggler/Center Finder S828 and four different attachments adapt to countless applications and are readily interchangeable. The attachments are snapped in the chuck without removing the collet nut and are clamped by a ball swivel-joint that permits adjustment to an angular position or true concentricity.

With Pointed Shank 828A, working centers can be quickly and accurately located. Spring tension on the ball of the point permits guiding the point to true concentricity so that the work can be brought into perfect alignment with the machine spindle.

Ball Contact 828B is useful in locating work by first bringing the contact (ball diameter .250" or 6.35mm) against the work, a slot, hole, shoulder, or end, and indexing the work to the desired position relative to the spindle.

Disc Contact 828C, which has a small disc at the end (.100"/2.54mm) diameter, permits use in more confined areas such as slots or shallow holes.

Offset Indicator Holder 828D with the Last Word® Test Indicators, the user can sweep holes or O.D.s for checking run-out or concentricity, establish center distances, check straightness or alignment of flat surfaces.



828B PT09186 828C 828D

828A

Complete set with case includes: 828B Ball Contact, 828A Wiggle/Center Finder with pointed shank, 828C Disc Contact, and 828D Offset Indicator Holder

Wiggler or Center Finder with Attachments

| Cat. No. | EDP | Description |
|----------|-------|--|
| S828HZ | 53064 | Wiggler/Center Finder, Complete with case and 4 attachments, 828B, C, D, PT09186 |
| S828 | 53065 | Wiggler/Center Finder with 3 Attachments, 828B, C, PT09186, without indicator holder, without case |
| 828A | 53066 | Wiggler/Center finder with pointed shank |
| PT09186 | 71164 | Pointed Shank only |
| 828B | 53067 | Ball contact only (.250"/6.35mm ball) |
| 828C | 53068 | Disc contact only (.100"/2.54mm disc) |
| 828D | 53069 | Offset indicator holder only |



827B with double end



Above: Locating the center with 827MB
Left: Locating the edge of a part with 827MA

827 EDGE FINDERS

.375", .500" AND 10MM BODY DIAMETERS FOR FAST, ACCURATE WORK LOCATION

Work surfaces may be located easily, quickly and accurately with these edge finders. Work with flat, straight edges, shoulders, grooves, round work, studs, dowels or center points and scribed lines – all can be accurately located with this handy tool. Body and contacts are made of tool steel, hardened, ground and lapped to close tolerances for diameter and concentricity.

How To Use:

Edge finders are easy to use. They are placed in a collet or chuck. The worktable is then traversed to obtain contact between the rotating edge finder and the work. Contact will shift to concentric position relative to the body and with very slight additional table adjustment, will move off center with a decided wobble. At this point, the center of the finder is exactly one-half the diameter of the contact from the work edge, permitting accurate location for other machining operations relative to the edge.

For locating center points and scribed lines, the pointed contact is used by putting a pencil or rule against the center point and making it run concentrically. Then the point is brought down to the center point or intersection of scribed lines and the table is adjusted so that when the tool barely touches the work, the lineup with the point in question can be ascertained.

827 Edge Finders

| Cat. No. | EDP | Body Diameter | Contact Diameter | Description |
|----------|-------|---------------|---------------------------|-------------|
| 827A | 53062 | .375" | .200" | Single End |
| 827B | 53063 | .500" | .200" and pointed contact | Double End |
| 827MA | 56041 | 10mm | 6mm | Single End |
| 827MB | 66452 | 10mm | 6mm and pointed contact | Double End |

Furnished in attractive, protective case.



PRECISION SHOP TOOLS

COLLET ADAPTER

This is a timesaving accessory for our 827A Edge Finders. It allows quick installation and removal of the edge finder, eliminating the need for collet changes on Bridgeports and similar machines.

It can also be used with any other attachment with a 3/8" post.

The progressive steps are: 1/4", 5/16", 3/8", 1/2", 5/8", 3/4" and 1". Step depths vary from .100" to .200".

| Collet Adapter | | |
|----------------|-------|----------------|
| Cat. No. | EDP | Description |
| PT28314 | 68846 | Collet Adapter |



PRECISION SHOP TOOLS



SF190 "Little Giant" Jack Screw set, complete with all attachments

"LITTLE GIANT" JACK SCREWS

190

2-1/4"–3-3/8"/57-85MM

191

1-1/2"–2-1/4"/38-57MM

"Little Giant" Jack Screws are very handy for leveling work on planer beds, upright drills, setting up machinery, and for general use in the toolroom or machine shop.

190 and 191 have 20-pitch screws and for those who desire a finer adjustment, the F190 has a 40-pitch screw.

An auxiliary pointed screw (D) is supplied, to be used in place of the screw with swivel cap. Extension base (E) is furnished for places where it is not possible to obtain a bearing on a flat surface. Extension V base (F) is for use against a cylindrical form.

| 190 and 191 "Little Giant" Jack Screws | | | | | |
|--|----------|-------|----------|-------|---|
| Photo Key | Cat. No. | EDP | Cat. No. | EDP | Description |
| | SF190 | 64622 | | | Set complete, with fine-adjusting screw and all attachments |
| | S190 | 50680 | S191 | 50687 | Set complete with all attachments |
| A | F190A | 64623 | | | Jack only, with fine-adjusting screw |
| | 190A | 50681 | 191A | 50688 | Jack only |
| B | 190B | 50682 | 191B | 50689 | Extension base |
| C | 190C | 50683 | 191C | 50690 | Extension base |
| D | F190D | 64624 | | | Auxiliary pointed screw with fine-adjusting screw |
| | 190D | 50684 | 191D | 50691 | Auxiliary pointed screw |
| E | 190E | 50685 | 191E | 50692 | Extension base |
| F | 190F | 50686 | 191F | 50693 | Extension V base |

| 190 Specifications | | | | | | | | | | |
|--------------------|-------|---------------------------------|-----|------------------------|----|---------------|----|---------------|----|--|
| Range | | Maximum Height with Attachments | | Jack (A) Base Diameter | | Extension (B) | | Extension (C) | | |
| in | mm | in | mm | in | mm | in | mm | in | mm | |
| 2-1/4 – 3-3/8 | 57-85 | 6-3/8" | 162 | 1-1/4 | 32 | 2 | 50 | 1 | 25 | |

| 191 Specifications | | | | | | | | | | |
|--------------------|-------|---------------------------------|----|------------------------|----|---------------|----|---------------|----|--|
| Range | | Maximum Height with Attachments | | Jack (A) Base Diameter | | Extension (B) | | Extension (C) | | |
| in | mm | in | mm | in | mm | in | mm | in | mm | |
| 1-1/2 – 2-1/4 | 38-57 | 3-3/4 | 95 | 1 | 25 | 1 | 25 | 1/2 | 13 | |



PRECISION SHOP TOOLS

815 TOOLMAKERS' HAMMER WITH BUILT-IN MAGNIFYING LENS

A PRACTICAL TOOL – MAKES A GREAT GIFT TOO!

Faster, easier and more accurate spotting and punching of centerlines and intersections is now possible with the this tool.

High-power magnification makes it easy to spot the punch and strike without once removing the eyes from the work.

Weighing only four ounces (113 grams) it is made of a steel forged chromium with plated finish. Both flat and ball peen heads are hardened and are offset for use in corners or close to obstructions. Shock resistant lens and hang hole.

| 815 Toolmakers' Hammer with Built-In Magnifying Lens | | |
|--|-------|-------------------------------------|
| Cat. No. | EDP | Description |
| 815 | 53041 | Hammer only |
| 815P | 53042 | Personalized (specify name clearly) |

129 BENCH BLOCKS

The 129 Bench Block is useful for holding work when driving pins, drilling, etc. The block is made from hardened steel and ground. A V-groove across the face accommodates round and odd-shaped stock. The smooth finish preserves the finish of the work being held.

The knurled side provides a good gripping surface, making it easier to handle. Recessed base to make it lighter, yet withstands hard usage.

| 129 Bench Blocks | | | |
|------------------|-------|------------------------|--|
| Cat. No. | EDP | Size Diameter x Height | Description |
| 129 | 50559 | 3 x 1-1/2" (75 x 38mm) | 129 bench block with oversize holes from 1/8-5/8" (3-16mm) diameter and one V-Groove |

119 BENCH BLOCKS

The 119 Bench Block is a good choice for all-around machine shop and toolroom use when a larger, heavy-duty block is required. This block weighs five pounds (2.3kg). The base is hex-shaped, so the block can be held rigidly in a vise. It is made from alloy steel, hardened, and ground, top and bottom.

| 119 Bench Blocks | | | |
|------------------|-------|-----------------------------|---|
| Cat. No. | EDP | Size Diameter x Height | Description |
| 119 | 50491 | 4-7/8 x 1-1/2" (120 x 38mm) | 119 Bench Block with ten oversize holes from 1/8-7/8" (3-22mm) diameter and two V-Grooves at right angles |



Above: 129
Right: 119

Locating hole center on a workpiece with the 117B Center Punch and 815 Toolmakers' Hammer



PUNCHES

AUTOMATIC CENTER PUNCHES WITH ADJUSTABLE STROKE

18

Rugged automatic punches with all-steel handles and parts

- Internal mechanism automatically strikes a blow when downward pressure is applied
- Adjustable knurled cap regulates the force of the blow
- Spring tension, which regulates the blow, is constant so marks made by the point are uniform in depth and size for each setting
- All sizes are identical in style, differing only in the striking power
- The point can be easily removed for regrinding or replacement
- Heavy-duty 18C is capable of striking a much heavier blow than the other sizes

| Automatic Center Punches with Adjustable Stroke | | | | | | |
|---|-------|--------|-----|----------|----|-------------------|
| Cat. No. | EDP | Length | | Diameter | | Description |
| | | in | mm | in | mm | |
| 18AA | 50119 | 4 | 100 | 7/16 | 11 | Punch |
| 18A | 50120 | 5 | 125 | 9/16 | 14 | Punch |
| 18C | 56757 | 5-1/4 | 130 | 11/16 | 17 | Punch, Heavy-Duty |

| Accessories | | |
|-------------|-------|---------------------|
| Part No. | EDP | Description |
| PT06689 | 12901 | Point only for 18AA |
| PT06690 | 12902 | Point only for 18A |
| PT22256 | 72445 | Point only for 18C |



Rugged automatic center punch with adjustable stroke

18A

818

This punch is similar to our 18C, except that it has a lightweight, knurled aluminum handle for a positive grip and easy handling

- No hammer required! Just hold the punch in an upright position, press the handle down, and a built-in mechanism strikes a perfect center mark every time.
- The force of the blow can be adjusted by turning the knurled cap
- All working parts made of properly hardened tool steel. Hardened tool steel point may easily be removed for resharpening or replacement. (Replacement PT22256)
- Works on metal, plastics, wood and other machinable materials

| 818 Automatic Center Punch | | | | | |
|----------------------------|-------|--------|-------|----------|----|
| Cat. No. | EDP | Length | | Diameter | |
| | | in | mm | in | mm |
| 818 | 53048 | 5 | 125mm | 5/8 | 16 |

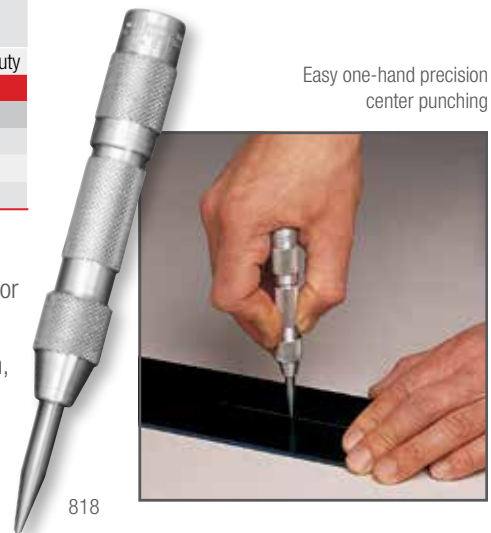

Easy one-hand precision center punching

818

819 HINGE-LOCATING

This automatic centering punch combines all the features of our 818 lightweight aluminum punch with an exclusive self-centering locating sleeve that automatically centers starter holes for screws

- Simply engage the beveled edge of the sleeve with the countersunk hole in the hinge and press down on the handle until the built-in mechanism strikes a blow for truly concentric starting holes every time. To draw hinges, etc., sideways, tilt the punch slightly in the opposite direction.
- Eliminates the risk of drilling off center, causing screws to pull hinges or hardware off center
- Punch can be adjusted for striking light or heavy impressions by turning the knurled cap
- Point is easily removed for replacement (Replacement PT09966-0)

| 819 Hinge-Locating Automatic Center Punch | | | | | |
|---|-------|--------|-----|----------|----|
| Cat. No. | EDP | Length | | Diameter | |
| | | in | mm | in | mm |
| 819 | 53049 | 5 | 125 | 5/8 | 16 |



Automatically locates and centers holes through hinges, latches, catches, etc.

819



PUNCHES

S117



117 CENTER PUNCHES WITH ROUND SHANKS

- Hardened and properly tempered
- Well proportioned
- Knurled finger grip
- Ground at the proper angle
- Accurately centered tips

264 CENTER PUNCHES WITH SQUARE SHANKS

- Hardened and properly tempered
- Square knurled grip
- Will not roll
- Accurately centered tips
- Ground at the proper angle

117 and 264 Center Punches

| 117 | | 264 | | Length | | Dia. at Top of Tapered Point | |
|----------|-------|----------|-------|--------|-----|------------------------------|-----|
| Cat. No. | EDP | Cat. No. | EDP | in | mm | in | mm |
| 117AA | 50482 | 264A | 51278 | 3 | 75 | 1/16 | 1.5 |
| | | 264B | 51279 | 3-1/2 | 88 | 5/64 | 2 |
| | | 264C | 51280 | 3-3/4 | 95 | 3/32 | 2.5 |
| 117A | 50483 | | | | | 5/64 | 2 |
| 117B | 50484 | 264D | 51281 | 4 | 100 | 3/32 | 2.5 |
| 117C | 50485 | | | | | 1/8 | 3 |
| 117D | 50486 | | | | | 5/32 | 4 |
| | | 264E | 51282 | 4-1/4 | 108 | 5/32 | 4 |
| | | 264F | 51283 | 4-1/2 | 114 | 3/16 | 5 |
| 117E | 50487 | 264G | 51284 | 5 | 125 | 1/4 | 6.5 |

117 and 264 Center Punch Sets

| Cat. No. | EDP | Description |
|----------|-------|---|
| S117PC | 50488 | Set of 5, 117AA, A, B, C, D in Plastic Case |
| S264WB | 51285 | Set of 7, 264A, B, C, D, E, F, G in Round Red Plastic Box |



PUNCHES



816 PRICK PUNCHES

- Accurately centered
- Ground at a sharp angle
- Hardened and tempered
- Knurled grip

800 SQUARE-HEAD NAIL SETS

- Round, knurled grip
- Large, square head
- Will not roll
- Beveled head prevents breakage
- Cupped punch surface
- Hardened and tempered steel

816 and 800 Punches

| 816 | | 800 | | Length | | Punch Diameter | |
|----------|-------|----------|-------|--------|-----|----------------|-----|
| Cat. No. | EDP | Cat. No. | EDP | in | mm | in | mm |
| 816A | 53043 | 800A | 53029 | 4 | 100 | 1/32 | 0.8 |
| | | 800B | 53030 | | | 1/16 | 1.5 |
| 816B | 53044 | 800C | 53031 | | | 3/32 | 2.5 |
| 816D | 53046 | 800D | 53032 | | | 1/8 | 3 |
| | | 800E | 53033 | | | 5/32 | 4 |

816 and 800 Punch Sets

| Cat. No. | EDP | Description |
|----------|-------|--|
| S816PC | 57078 | Combination Starrett Punch Set in Plastic Case. One Each 816A, B, D Prick Punches, and Two Center Punches 117AA, B |
| S800PC | 64131 | Set of 5 in Protective Plastic Case. One Each of 800A, B, C, D, E |



PUNCHES

565 DRIVE PIN PUNCHES

- Hardened and tempered steel
- Knurled grip



S565



S565PC



S565WB

SB565



S565Z

B565 BRASS DRIVE PIN PUNCHES

- Ideal for softer materials
- Solid brass prevents damaging delicate work
- Knurled grip

565 and B565 Drive Pin Punches

| 565 | | B565 | | Length | | Diameter Punch | |
|----------|-------|----------|-------|--------|-----|----------------|-----|
| Cat. No. | EDP | Cat. No. | EDP | in | mm | in | mm |
| 565A | 52578 | B565A | 12465 | 4 | 100 | 1/16 | 1.5 |
| 565B | 52579 | B565B | 12466 | | | 3/32 | 2.5 |
| 565C | 52580 | B565C | 12467 | | | 1/8 | 3 |
| 565D | 52581 | B565D | 12468 | | | 5/32 | 4 |
| 565E | 52582 | B565E | 12469 | | | 3/16 | 5 |
| 565F | 52583 | B565F | 12470 | | | 7/32 | 5.5 |
| 565G | 52584 | B565G | 12471 | | | 1/4 | 6 |
| 565H | 52585 | B565H | 12472 | | | 5/16 | 8 |

565 and B565 Drive Pin Punch Sets

| Cat. No. | EDP | Description |
|----------|-------|--|
| S565WB | 52586 | Set of 8 Punches (1 of Each Size) in Round Red Plastic Box |
| S565PC | 52587 | Set of 8 Punches (1 of Each Size) in Protective Vinyl Case |
| SB565Z | 12473 | Set of 8 Punches (1 of Each Size) in Fabric Pouch |



PUNCHES



248 DRIVE PIN PUNCHES FOR MACHINE SHOP AND MOTOR SERVICE WORK

- Extra-long drive pin punches, measuring 8" (200mm). The bodies are 4-1/2" (115mm) and the drive pin sections are 3-1/2" (90mm) long.
- Well-proportioned, hardened, properly tempered with a knurled grip
- Designed to withstand hard use
- Provide a most satisfactory punch for machine shop and motor service work
- Diameter of punches is slightly less than listed

B248 BRASS DRIVE PIN PUNCHES FOR MACHINE SHOP AND MOTOR SERVICE WORK

- Same features as 248 extended length drive pin punches, but in a softer brass construction ideal for more delicate work
- Available in four sizes from 3/16" to 3/8" and as a full set of four in an attractive fabric pouch

248 and B248 Drive Pin Punches

| 248 | | B248 Brass | | Length | | Diameter Punch | |
|----------|-------|------------|-------|--------|-----|----------------|-----|
| Cat. No. | EDP | Cat. No. | EDP | in | mm | in | mm |
| 248A | 51181 | | | 8 | 200 | 1/8 | 3 |
| 248B | 51182 | B248B | 12460 | | | 3/16 | 5 |
| 248C | 51183 | B248C | 12461 | | | 1/4 | 6 |
| 248D | 51184 | B248D | 12462 | | | 5/16 | 8 |
| 248E | 51185 | B248E | 12463 | | | 3/8 | 9.5 |

248 and B248 Drive Pin Punch Sets

| Cat. No. | EDP | Description |
|----------|-------|--|
| S248PC | 51186 | Set of 5 Punches (1 of Each Size) in Protective Vinyl Case |
| S248 | 51187 | Set of 5 Punches (1 of Each Size) in Plain Box |
| SB248Z | 12464 | Set of 4 Brass Punches (1 of Each Size) in Fabric Pouch |



SCREWDRIVERS



S555Z

S555Z-7



S551Z

S551Z-7



555 JEWELERS' SCREWDRIVERS

- Ideal for fine, delicate work
- Swivel knobs are concave to fit the finger
- Hexagonal knobs to prevent rolling
- Knurled grip
- Overall length of screwdrivers is approximately 3-3/4" (95mm)
- Replaceable blades available

551 PRECISION SCREWDRIVERS

The 551 Screwdrivers with soft-touch handle are lightweight and ergonomic. The blades are made of chromium-vanadium steel, hardened and chrome-plated, allowing them to hold up well in the toughest applications.

FEATURES

- Precision-machined tips for top quality and exact fit
- Vapor-chromed non-slip tips
- Hardened for maximum durability
- Tapered handles allow rapid rotation
- Swivel knobs are concave to fit finger

| 555 Jewelers' Screwdrivers | | | | | |
|--------------------------------|-------|--|-------|---------------|--------------------|
| Complete Screwdriver | | Blade Only | | Blade Width | Phillips Blade No. |
| Cat. No. | EDP | Part No. | EDP | (in/mm) | |
| 555AA | 52549 | PT02449AA | 70361 | .025" (0.6mm) | |
| 555A | 52550 | PT02449A | 70362 | .040" (1mm) | |
| 555B | 52551 | PT02449B | 70363 | .055" (1.4mm) | |
| 555C | 52552 | PT02449C | 70364 | .070" (1.8mm) | |
| 555D | 52553 | PT02449D | 70365 | .080" (2mm) | |
| 555E | 52554 | PT02449E | 70366 | .100" (2.5mm) | |
| 555F | 52561 | PT14443 | 71534 | | #0 |
| 555 Jewelers' Screwdriver Sets | | | | | |
| Cat. No. | EDP | Description | | | |
| S555Z-6 | 52564 | Set of 6 Screwdrivers, 555AA, A, B, C, D, E – In Case | | | |
| S555Z-7 | 52566 | Set of 7 Screwdrivers, 555AA, A, B, C, D, E, F – In Case | | | |

| 551 Precision Screwdrivers | | | |
|--------------------------------|-------|---|--------------------|
| Complete Screwdriver | | Blade Width (in/mm) | Phillips Blade No. |
| Cat. No. | EDP | | |
| 551A | 67195 | .060" (1.5mm) | |
| 551B | 67196 | .080" (2.0mm) | |
| 551C | 67197 | .100" (2.5mm) | |
| 551D | 67198 | .120" (3.0mm) | |
| 551E | 67199 | | #00 |
| 551F | 67200 | | #0 |
| 551G | 67201 | | #1 |
| 551 Precision Screwdriver Sets | | | |
| Cat. No. | EDP | Description | |
| S551Z-7 | 67203 | Set of 7 Screwdrivers With Case, 551A, B, C, D, E, F, G | |
| S551ZZ | 67204 | Case Only | |

STARRETT SCREWDRIVERS

- Made for relatively small and very delicate work
- Bodies are made from knurled, nickel-plated steel
- Replaceable blades, made from the best quality steel, properly tempered and nickel-plated
- A slight turn of the knurled chuck locks the blade in place
- Blades can be reversed into the screwdriver body for safety





SCREWDRIVERS

553 POCKET SCREWDRIVERS

The 553 Screwdrivers feature a hexagonally shaped head to prevent them from rolling. When not in use, the blade can be reversed into the screwdriver body for conveniently and safely carrying them in pockets. Size takes no more room than a penknife.

Handy steel and carbide scriber points are also available to fit these handles, including 70 Scriber points.

FEATURES

- Hexagonal head prevents rolling
- Small in size with reversable/removable blade
- Steel and carbide scriber points available
- Knurled grip



553

553 Pocket Screwdrivers

| Cat. No. | EDP | Blade Only | | Blade Width | | Blade Length | |
|----------|-------|------------|-------|-------------|-----|--------------|----|
| | | Part No. | EDP | in | mm | in | mm |
| 553A | 52543 | PT02351A | 70330 | .100 | 2.5 | 1-7/8 | 48 |
| 553B | 52544 | PT02351B | 70331 | .150 | 3.8 | 3 | 75 |

Scriber Points Only

| Steel | | Carbide | | Fits Model |
|----------|-------|----------|-------|------------|
| Cat. No. | EDP | Cat. No. | EDP | |
| PT02355B | 70333 | PT19306 | 72049 | 553B |



PRECISION SHOP TOOLS

161 TOOLMAKERS' PARALLEL CLAMPS

These parallel clamps are designed for maximum strength and rigidity. They are extremely useful for holding work together in tapping and drilling and on various machine setups. The ends of the jaws are tapered to permit clamping under shoulders or in recesses.

A retaining ring holds the loose jaw in alignment when the clamp is being opened or closed. The clamps are made of steel, nicely finished and hardened.

| | | | | | | |
|-------|-------|-------|----|---------|------|--------------|
| 161AA | 50593 | 3/4 | 19 | 21/32 | 16.5 | Single Clamp |
| 161A | 50594 | 1-1/4 | 32 | 13/16 | 20.5 | Single Clamp |
| 161B | 50595 | 1-3/4 | 44 | 1 | 25 | Single Clamp |
| 161C | 50596 | 2-1/4 | 57 | 1-7/32 | 30 | Single Clamp |
| 161D | 50597 | 2-3/4 | 70 | 1-25/32 | 45 | Single Clamp |
| 161E | 50598 | 3-1/2 | 89 | 2-1/4 | 57 | Single Clamp |



161 Clamps



580 PRECISION ANGLE PLATE

These angle plates are invaluable for accurate work in toolroom and small production applications when flatness, squareness and parallelism is important.

- Hardened and tempered steel
- Precision ground, square and parallel
- Convenient step for smaller work 3/4" (19mm) down from the top and a 1/4" (6.35mm) seat
- 10 holes tapped with a 1/4-20 thread for fastening to fixtures and clamping work to the angle plate

| 580 Precision Angle Plate | | | | |
|---------------------------|-------|------------------|--------------|-------------|
| Cat. No. | EDP | Size/Description | | Description |
| | | in | mm | |
| 580 | 64961 | 3 x 3 x 3 | 75 x 75 x 75 | Angle Plate |

54 HOLD-DOWNS

- Improved design firmly holds work flat on a machine bed or in a vise
- Contact edges are tapered to hold work securely and force it downward to the bed of the machine or against any parallel surface
- Especially useful for holding small work or thin materials without distortion
- Made of tool steel, hardened and ground

| 54 Hold-Downs | | | | | |
|---------------|-------|--------|-----|-------|----|
| Cat. No. | EDP | Length | | Width | |
| | | in | mm | in | mm |
| 54A (Pair) | 50274 | 4 | 100 | 27/32 | 21 |



54A



VICES AND CLAMPS

581 Precision Grinding Vise

- Extremely useful for accurate grinding
- Hardened steel construction
- Ground flat, square, and parallel within .0002" (0.005mm)
- Jaw pressure on workpiece is forward and downward for repeatable positioning and maximum holding power
- Jaw opening 4" (100mm), jaw depth 1-1/4" (32mm)
- Movable jaw is slightly narrower than the base, enabling the vise to be used on its side
- 1/4-20 tapped hole in each side of the solid jaw to allow the use of a stop for repetitive operations
- "T" handle wrench provided for tightening the movable jaw
- Four drilled and counterbored holes for 5/16 bolts in the base of the vise for bolting to a sine plate or the bed of a machine tool
- Angle blocks available on special order
- For attaching special jaw plates, two holes are drilled in both the solid and movable jaws

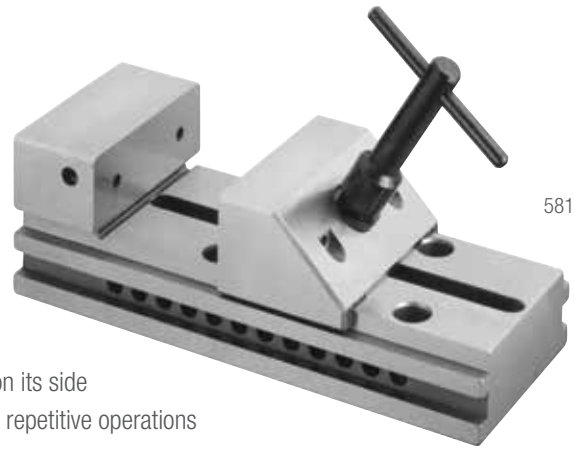

581

581 Precision Grinding Vise

| Cat. No. | EDP | Capacity Jaw Opening x Depth | | Description |
|----------|-------|------------------------------|----------|------------------------------------|
| | | in | mm | |
| 581 | 64962 | 4 x 1-1/4 | 100 x 32 | Grinding Vise with T-Handle Wrench |

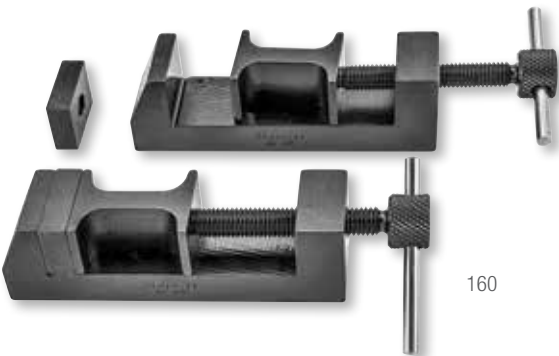

160

160 TOOLMAKERS' STEEL CLAMPS

These clamps are useful in layout work or for holding work securely in drilling and other similar operations. Each clamp is furnished with two take-up blocks that slip on the end of the screw. The blocks are held to allow a slight swivel action that conforms the angle of the block to the shape of the work being held.

There is a hole in the base of the clamps so they may be fastened to the bench and used as a small vise. Clamps are made of case-hardened steel and are smoothly finished.

160 Toolmakers' Steel Clamps

| Cat. No. | EDP | Capacity | | Description |
|----------|-------|----------|----|----------------|
| | | in | mm | |
| 160 | 50592 | 2 | 50 | Pair of Clamps |



PIN VISES



S240

240 PIN VISES WITH TAPERED COLLETS

.010-.200"/0.25-5.1MM

- Special tapered collet, providing maximum clamping surface
- Smaller body diameter than the chuck to allow fast opening and closing and rapid rotation when used on small work
- Available individually or as a complete set in a convenient case

240 Pin Vises

| Cat. No. | EDP | Range in | mm |
|----------|-------|-----------|----------|
| 240A | 51136 | .010-.055 | 0.25-1.4 |
| 240B | 51137 | .025-.075 | 0.64-1.9 |
| 240C | 51138 | .045-.135 | 1.2-3.4 |
| 240D | 51139 | .110-.200 | 2.8-5.1 |

240 Pin Vise Sets

| Cat. No. | EDP | Description |
|----------|-------|---|
| S240Z | 51140 | Set of All 4 Sizes in Protective Vinyl Case |



S162

162 PIN VISES

0-.187"/0-4.8MM

The handles of these pin vises are reduced in size so that they can be rapidly rotated between thumb and finger when filing small work.

162 Pin Vises

| Cat. No. | EDP | Range in | mm |
|----------|-------|-----------|---------|
| 162A | 50599 | 0-.040 | 0-1 |
| 162B | 50600 | .030-.062 | 0.8-1.6 |
| 162C | 50601 | .050-.125 | 1.3-3.2 |
| 162D | 50602 | .115-.187 | 2.9-4.8 |

162 Pin Vise Sets

| Cat. No. | EDP | Description |
|----------|-------|---|
| S162Z | 50604 | Set of All 4 Sizes in Protective Vinyl Case |



165

165 DOUBLE END PIN VISE

0-.125"/0-3.2MM

- Reversible collets with two size capacities at each end
- One chuck holds work or tools 0-.031" and .093-.125" diameter (0-0.8mm and 2.5-3.2mm). The other chuck holds .031-.062" and .062-.093" diameter (0.8-1.6mm and 1.6-2.5mm).
- "Back support" provided by beveled chuck ends

165 Double End Pin Vise

| Cat. No. | EDP | Range in | mm |
|----------|-------|----------|-------|
| 165 | 50608 | 0-.125 | 0-3.2 |



S166

166 PIN VISES WITH INSULATED, OCTAGONAL HANDLES

0-.187"/0-4.8MM

These pin vises are the same as our 162 except that they have an insulating PVC handle which is octagonally shaped, preventing them from rolling when laid down.

166 Pin Vises

| Cat. No. | EDP | Range in | mm |
|----------|-------|-----------|---------|
| 166A | 50609 | 0-.040 | 0-1 |
| 166B | 50610 | .030-.062 | 0.8-1.6 |
| 166C | 50611 | .050-.125 | 1.3-3.2 |
| 166D | 50612 | .115-.187 | 2.9-4.8 |

166 Pin Vise Sets

| Cat. No. | EDP | Description |
|----------|-------|---|
| S166Z | 50614 | Set of All 4 Sizes in Protective Vinyl Case |

PIN VISES

Starrett pin vises are useful for securely holding small stock, taps, drills, reamers, scribes, wire, small files, and other tools. The jaws on all are hardened and with a few turns of the binding nut, a firm grip may be obtained. Handles and binding nuts are nickel-plated except for the 166 pin vise.

A hole extends through the full length of the handles so that wires of any length and any diameter up to the full size of the tool can be held.

NOTE: These tools not recommended for powered use.



PIN VISES

93 T-HANDLE TAP WRENCHES

The 93 T-Handle Tap Wrenches are for holding taps, drills, reamers and other small tools to be turned by hand. They are properly heat treated to withstand ordinary shop use. The jaws conform to the tool being held, making it rigid and less apt to loosen.

The 93D, E and F sizes are identical in construction to the 93A, B and C models, except that the bodies are proportionately longer. These longer tap wrenches are very handy in machine, automobile service and aviation repair shops because they eliminate the need for stocking special long taps for depths which cannot be reached with shorter wrenches.

FEATURES

- Sliding handle is frictionally held, permitting the handle to be removed or positioned

NOTE: These tools are designed to hold square shanks. Round shanks can be gripped, but care must be used. Excessive tightening may break the binding nut.

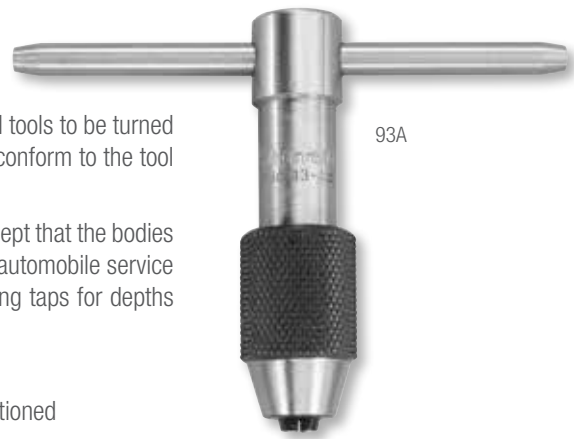

93A

| 93 T-Handle Tap Wrenches | | | | | | | |
|--------------------------|-------|-------------------|----------|--------------|-------|-------------|-----|
| Cat. No. | EDP | Capacity Tap Size | | Square Shank | | Body Length | |
| | | in | mm | in | mm | in | mm |
| 93A | 50427 | 1/16-3/16 | 1.6-4.7 | 1/16-5/32 | 1.6-4 | 2 | 50 |
| 93B | 50428 | 7/32-7/16 | 5.5-11 | 5/32-1/4 | 4-6.4 | 2-1/2 | 65 |
| 93C | 50429 | 1/4-1/2 | 6.4-12.7 | 3/16-5/16 | 4.7-8 | 3-1/2 | 90 |
| 93D | 50430 | 1/16-3/16 | 1.6-4.7 | 1/16-5/32 | 1.6-4 | 6 | 150 |
| 93E | 50431 | 7/32-7/16 | 5.5-11 | 5/32-1/4 | 4-6.4 | 10 | 250 |
| 93F | 50432 | 1/4-1/2 | 6.4-12.7 | 3/16-5/16 | 4.7-8 | 13 | 330 |

91 TAP WRENCHES

The 91 Tap Wrenches are strong and well proportioned. They are nicely finished and the gripping surfaces are properly tempered. They will firmly hold square or round shanks. They are plunger operated by knurled sleeve – the spring inside the sleeve causes plunger to back off when pressure is removed.

NOTE: Round shanks can be gripped, but care must be used. Excessive pressure may break the moveable V-jaw.



91A

| 91 Tap Wrenches | | | | | | | |
|-----------------|-------|-------------------|----------|--------------|--------|-------------|-----|
| Cat. No. | EDP | Capacity Tap Size | | Square Shank | | Body Length | |
| | | in | mm | in | mm | in | mm |
| 91A | 50419 | 1/16-1/4 | 1.6-6.35 | 3/32-5/32 | 2.4-4 | 6 | 150 |
| 91B | 50420 | 3/16-1/2 | 4.7-12.7 | 5/32-9/32 | 4-7 | 9 | 225 |
| 91C | 50421 | 1/4-5/8 | 6.35-16 | 5/32-3/8 | 4-9.5 | 12 | 300 |
| 91D | 50422 | 5/16-3/4 | 8-19 | 13/64-7/16 | 5.2-11 | 16 | 400 |

174 TAP WRENCH

This is a well-designed tap wrench, ideal for holding smaller diameter taps, drills, reamers and other tools up to 1/4" (6.35mm) in diameter.

It will firmly grip round or square shanks. It is lightweight, well proportioned, and the gripping surface is properly heat treated.



174

| 174 Tap Wrench | | | | | | | |
|----------------|-------|-------------------|--------------|--------------|-------|-------------|----|
| Cat. No. | EDP | Capacity Tap Size | | Square Shank | | Body Length | |
| | | in | mm | in | mm | in | mm |
| 174 | 50658 | No. 0-14 | 1/4 diameter | 6.35 | 3-5/8 | 90 | |



FIXTURING

268 V-BLOCKS AND CLAMP

1-1/8"/28MM CAPACITY

- Cast iron construction
- 1-1/2" (38mm) square and 2" (50mm) long
- Clamp is ribbed for extra strength and will hold work up to 1-1/8" (28mm) in diameter

268 V-Blocks and Clamp

| Cat. No. | EDP | Capacity in | mm | Description |
|----------|-------|-------------|----|---|
| 268A | 51287 | 1-1/8 | 28 | 2 V-Blocks (one pair) |
| 268C | 51289 | | | Complete set with 2 V-Blocks (one pair) and clamp |

268 V-Blocks and Clamp Accessories

| Cat. No. | EDP | Description |
|----------|-------|-------------|
| 268B | 51288 | Clamp only |



268C with Clamp

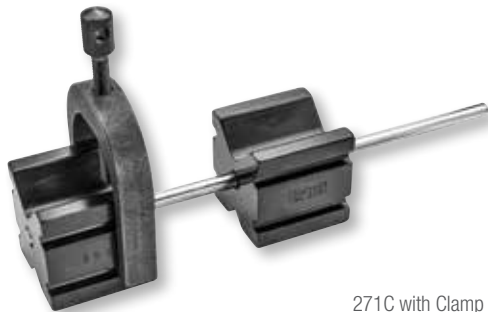

271C with Clamp

271 V-BLOCKS AND CLAMP

1-1/4"/32MM CAPACITY

- Case hardened steel for wear resistance
- For use singly or in pairs
- Includes a steel rod that passes through each block, firmly held by friction positioning to keep blocks in alignment
- Two grooves on each side of the blocks will hold the clamp for small or large work
- Steel forged clamp holds work up to 1-1/4" (32mm) in diameter

271 V-Blocks and Clamp

| Cat. No. | EDP | Capacity in | mm | Description |
|----------|-------|-------------|----|---|
| 271A | 51293 | 1-1/4 | 32 | 2 V-Blocks (one pair) |
| 271C | 51295 | | | Complete set with 2 V-Blocks (one pair) and clamp |

271 V-Blocks and Clamp Accessories

| Cat. No. | EDP | Description |
|----------|-------|-------------|
| 271B | 51294 | Clamp only |

278 V-BLOCKS AND CLAMPS

1"/25MM CAPACITY

- Precision ground to extreme accuracy
- Vees are central, parallel, and square with the ends and sides
- Hardened and ground steel construction
- Numbered in series so the vees in each set are always in alignment
- 1/4-20 tapped hole through the sides for attachment to an angle iron that can then be attached to a lathe faceplate or held by a magnetic chuck
- Each block is 1-1/4" (32mm) square and 1-5/8" (40mm) long

278 V-Blocks and Clamps

| Cat. No. | EDP | Capacity in | mm | Description |
|----------|-------|-------------|----|--|
| 278 | 51312 | 1 | 25 | Complete Set with 2 V-Blocks (One Pair) and 2 Clamps |

278 V-Blocks and Clamp Accessories

| Cat. No. | EDP | Description |
|----------|-------|-------------|
| 278B | 51313 | Clamp Only |



278 with Clamps

PRECISION V-BLOCKS AND CLAMPS

Starrett V-Blocks come in a variety of styles to suit the numerous requirements of machinists. They are for general shop use and layout work, as well as for holding stock in place during light-duty milling, drilling, and grinding operations. All clamp screws have a hole to help secure the workpiece.





FIXTURING

566 DUAL-VEE MAGNETIC V-BLOCK

1-3/4"/44MM CAPACITY

- Designed for versatility and accuracy
- All working surfaces are precision ground
- Two precision vees will hold round stock sizes from 1/4 - 1-3/4" (6.4-44mm) diameter
- Powerful, permanent magnet is controlled by a rotary switch
- All working surfaces are heat treated for long wear and stability
- Each block is 2-1/2" wide x 3" high x 3" long (63 x 75 x 75mm)



566

566 Dual-Vee Magnetic V-Block

| Cat. No. | EDP | Capacity in | mm | Description |
|----------|-------|----------------|----|---------------------------|
| 566 | 63323 | 1-3/4 | 44 | Dual-Vee Magnetic V-Block |

568 V-BLOCKS AND CLAMPS FOR ROUND OR SQUARE WORK

2"/50MM ROUND CAPACITY

1-7/16"/36MM SQUARE CAPACITY

These rugged and versatile blocks have the following features:

- Hardened steel, precision ground parallel and square
- V-grooves are ground central and parallel to the sides and base – perfect alignment in matched pairs
- Clamps have screw holes at 45° and 90° to hold either square or round work
- Stepped groove construction permits high or low clamp mounting for small or large work
- Clamps do not project over the width of the block, permitting it to be used on the base, ends or sides
- 3/8-16 tapped holes permit mounting blocks on faceplates or angle irons
- Each block is 2-1/2" long x 3" wide x 2" high (63 x 75 x 50mm)

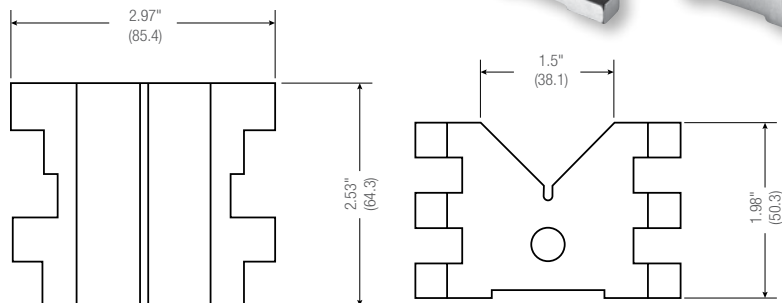
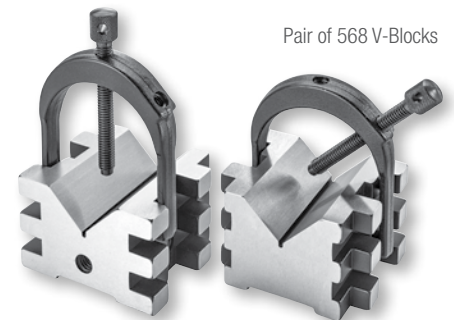

568 V-Blocks and Clamps

| Cat. No. | EDP | Capacity | Description |
|----------|-------|---|--|
| 568A | 52590 | 2" (50mm) dia. round; 1-7/16" (36mm) square | 1 V-Block and clamp |
| 568C | 52592 | (1-9/16" [40mm] with screw at top) | Complete set with 2 V-Blocks and 2 clamps (matched pair) |

568 V-Blocks and Clamp Accessories

| Cat. No. | EDP | Description |
|----------|-------|-------------|
| 568B | 52591 | Clamp Only |



FIXTURING

567 V-BLOCK AND CLAMP

1-5/16"/33MM CAPACITY

- The clamp is smaller than the outside width of the block, but has an adjustable side screw to support the block and prevent tilting
- The V at the stepped end is at right angles to the base and is handy for holding shouldered studs, pins, etc.
- A clearance hole for drilling or removing dowel pins is provided in the block
- The block has four 3/8-16 tapped holes, two in the base and one on each side for attachment to an angle iron. The angle iron holding the block can then be attached to a lathe faceplate or held by a magnetic chuck.
- The clamp is a strong forging
- The block is hardened and precision ground. The sides are parallel and the V is central and parallel to the sides and base.
- Can be used on its base, on the end or on either side

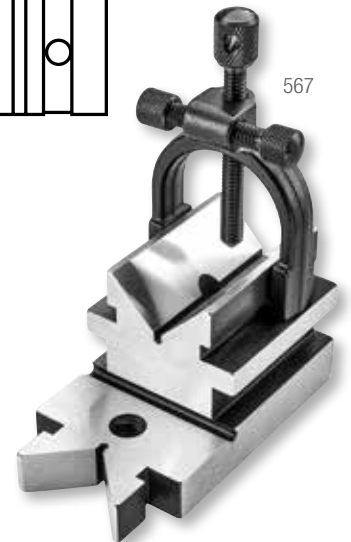
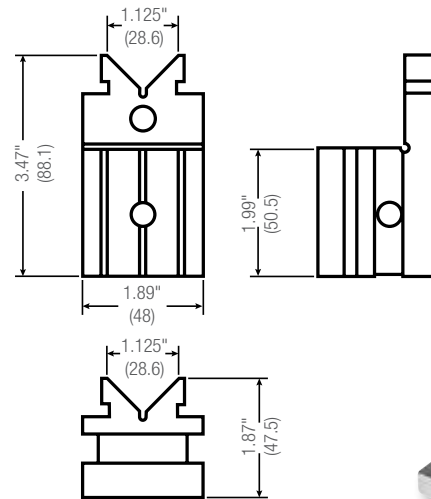

567 V-Block and Clamp

| Cat. No. | EDP | Capacity | | Description |
|----------|-------|----------|----|---|
| | | in | mm | |
| 567 | 52588 | 1-5/16 | 33 | Complete set with 1 V-Block and 1 clamp |

567 V-Block and Clamp Accessories

| Cat. No. | EDP | Description |
|----------|-------|-------------|
| 567B | 70885 | Clamp only |

578 V-BLOCK AND CLAMP FOR LARGER CAPACITY WORK

4"/100MM CAPACITY

This is our largest capacity V-block, which is ideal for toolroom, inspection and production work. Hardened steel

- Precision ground flat, square and parallel
- Rugged, reversible, hardened clamp can accommodate 9/16-4" (14-100mm) diameters of almost any shape of work
- No clamp interference when the block lies on either side
- Three available clamp positions
- Two tapped holes (3/8-16) in one end for mounting the V-block perpendicular to faceplates, etc.
- Available in matched pairs by special order

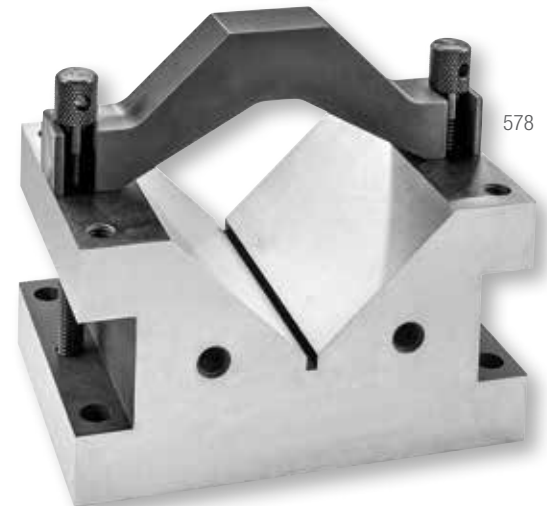

Above: V-Block with reversible clamp in downward facing position
(Line drawing illustrates clamp in upward facing position)

578 V-Block and Clamp

| Cat. No. | EDP | Description |
|----------|-------|--|
| 578 | 64960 | V-Block and clamp for larger capacity work |
| 578B | 64988 | Clamp only with 2 screws |

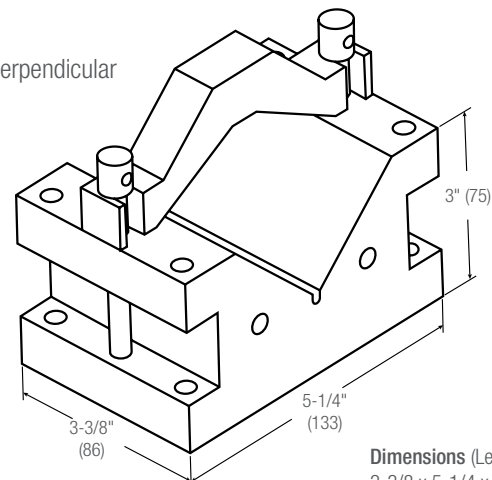

Dimensions (Length x Width x Height):
3-3/8 x 5-1/4 x 3" (86 x 133 x 75mm)



Using the hand vise with clamp mounted for benchwork applications



FIXTURING

86 COMBINATION HAND VISE

The 86 Combination Hand and Bench Vise has a wide range of uses for all toolmakers, mechanics, hobbyists and do-it-yourselfers. When a vise is needed at different locations for convenience, this tool is indispensable. By removing the handle and substituting the clamp, the tool may be fastened to benches, shelves, etc., approximately 1/2 - 2-1/8" (13-54mm) in thickness, and can be adjusted to different positions according to the user's preference.

When used as a hand vise, the leverage obtainable with the ball end lever will be appreciated in comparison with a wing nut commonly employed for this purpose. The jaws are made from forgings and are properly tempered.

| 86 Combination Hand Vise | | | | |
|--------------------------|-------|-------------|----|----------------------|
| Cat. No. | EDP | Capacity in | mm | Description |
| 86A | 50404 | 1-1/2 | 38 | Hand Vise with Clamp |

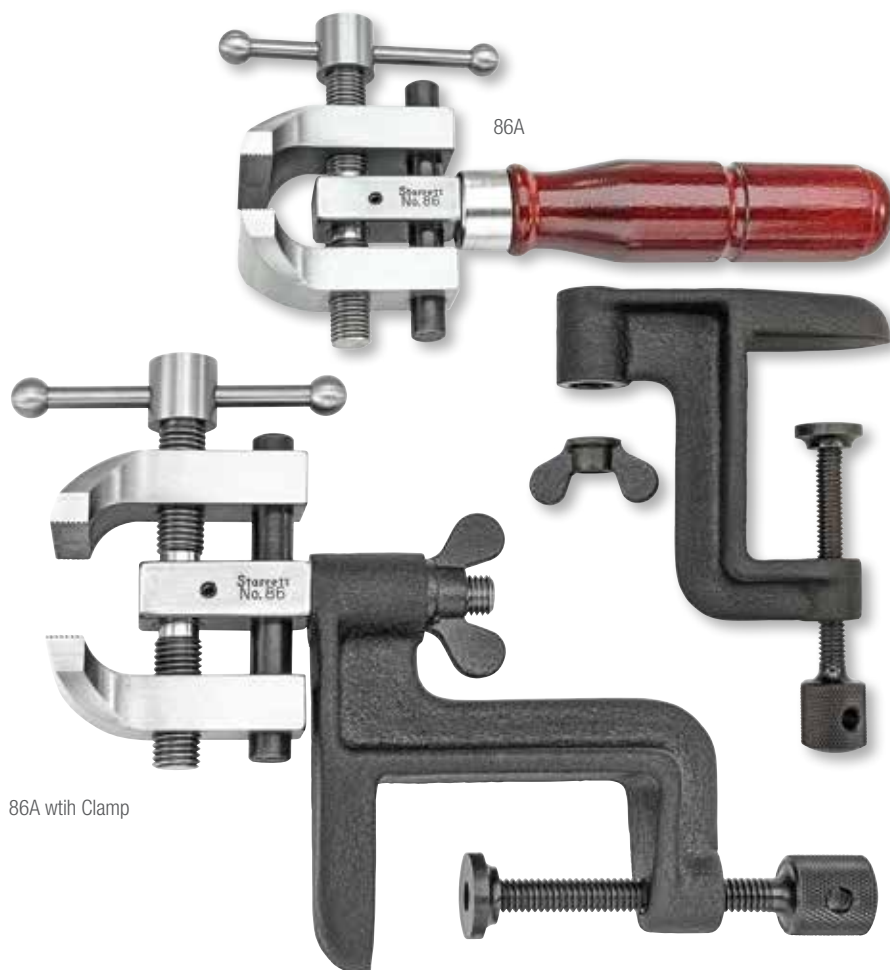

86A with Clamp



M1 OIL

M1® INDUSTRIAL QUALITY ALL-PURPOSE LUBRICANT

M1 is the "modern one" – the superior alternative. It dries and will not attract dirt, dust or other contaminants as other leading lubricants do.

Starrett is a leader in precision measuring tools. We use M1 in our manufacturing areas and it works. M1 will work for you too. The best lubricant value for your money.

- M1 produces a micro-thin, airtight coating/film that simultaneously dries as it protects, avoiding dirt, grime, etc., that other "wet" lubricants actually attract
- The can will spray upside down in awkward places without losing propellant power

12 oz. Aerosol Can



1 pt. Spray bottle sold empty for refilling from bulk container

Lubricates: M1 is free of silicone, making it an excellent lubricant. Its ability to stand up to extreme temperatures makes it ideal year-round.

Penetrates: Deep-down penetration works quickly to free frozen nuts, bolts, and metal parts. Actually gets under caked-on dirt to clean the metal for removal.

Prevents Rust: Protects metal against rust and corrosion damage by providing a molecular shield that locks to the metal.

Cleans: Actually removes grease, tar, and grime from metal parts and painted surfaces. Cleans and polishes for lasting protection.

Stops Squeaks: Has instant lubrication properties that spread into those hard-to-reach metal parts to stop squeaking and sticking.

Displaces Moisture: M1 is not soluble in water, so it gets under moisture to lift it away from the surface to be protected.

Nonconductive: Prevents short circuits in high moisture environments, halts electrical leakage from wet ignition wires.



M1 Aerosol Cans spray upside down and in awkward places. Spray wand (shown) is included with each aerosol can.



INDUSTRIAL APPLICATIONS

Applications for industry are endless. Protect working surfaces of machinery, use in dip tanks to protect production parts in process, or apply on tools when stored. M1 is also ideal in highly corrosive situations that destroy metal equipment like rollers, racks, conveyors, etc. used in marine environments.

UNIVERSAL APPLICATIONS

Use to dry wet automotive ignition systems. Great on ski bindings and prevents snow from sticking to shovels. Ideal on sticky drawer slides and window frames. Removes tar from car bumpers and painted surfaces. Can also be easily removed to prepare surfaces for painting. Use on tools, hinges, appliances, guns, knives, bicycles, mowers, fishing gear, locks, and more.

BULK CONTAINERS

Larger size containers of M1 make economical sense. You can also use and refill the handy spray dispenser bottle that saves you money and prevents the unwanted waste and disposal of empty cans.



1 Gallon (3.8 liters)



5 Gallon (19 liters)



53 Gallon Drum (200 liters)

| M1 All-Purpose Lubricant | | |
|--------------------------|-------|--|
| Cat. No. | EDP | Description |
| M1.95173 | 95173 | Case of 12/12 oz. (0.3 liter) aerosol cans |
| Bulk Containers | | |
| Cat. No. | EDP | Description |
| M-1.01 | 93221 | 4/1 gal. (3.8 liter) containers |
| M-1.05 | 93227 | 5 Gal. (19 liters) |
| M-1.53 | 93233 | 53 gal. (200 liters) drum |
| Spray Dispenser | | |
| Cat. No. | EDP | Description |
| M-1.15 | 93251 | Case of 4/1 pint (0.5 liter) empty spray bottles |



M1 is available in bulk for industrial applications in 1 Gallon Cans, 5 Gallon Pails, and 53 Gallon Drums.

| Specifications | |
|---|--|
| Color | Amber (clear) |
| Odor | Pleasant |
| Specific Gravity | .80 @ 60° F (15.5° C) |
| Viscosity | 2.2 cSt (centiStokes) converts to 10.5 SUS (seconds universal Saybolt) at 72° F (22.2° C) |
| Lubrication | 1500 lb (680.4 kg) of pressure (independent testing) |
| Flash Point | 174 °F (79 °C) T.C.C. |
| VOC (wt%) CARB Method 310 | 9.2 |
| Pour Point | -100° F (-73° C) excellent low temperature stability |
| Evaporation Rate | .7 (water = 1) |
| Coverage | 3500 to 4000 sq. ft. (72-82 sq. meters) per U.S. Gal. (4.5 liters) |
| Boiling Point, Initial | 370 - 470° F (187.8 - 243.3° C) |
| Weight, Applied Coating | 1.7 x 10 ⁻³ lb per sq. ft. |
| Film Thickness | .0004" (0.010mm) average |
| Dielectric Strength | 18,000v with .100" (2.54mm) gap |
| Humidity | Meets and exceeds ASTM-D655 zero rust after 1000 hours |
| Salt Spray | Meets and exceeds ASTM-B117 zero rust after 48 hours |
| | Indoor protection lasts up to a year. Outdoor protection – reapply as needed. |
| NSF registered 124332 Category Code H2 | Acceptable as a lubricant, release agent or anti-rust film on equipment and machinery parts in and around food processing areas where there is no possibility of direct food contact |



PRECISION SHOP TOOLS

1620 TOOL AND INSTRUMENT OIL

Special high-refining process makes Starrett Tool and Instrument Oil colorless, ensures thorough lubrication of close-fitting parts at extreme temperatures and provides a strong, lasting film over all areas requiring protection against rust.

FEATURES

- This oil is made to our specifications and used in our factory to lubricate and protect our precision measuring tools and instruments
- General purpose lubricant for a wide range of applications
- Ideal for maximum protection and lubrication of measuring tools, precision instruments and light machinery
- Guards highly finished tools, parts and machined surfaces against rust
- Protects firearms, fishing tackle and other sporting equipment and keeps working parts in perfect condition
- Cleans bright metals and polishes furniture
- Starrett oil can also be used for automobile generators, starters, hinges, locks, and springs

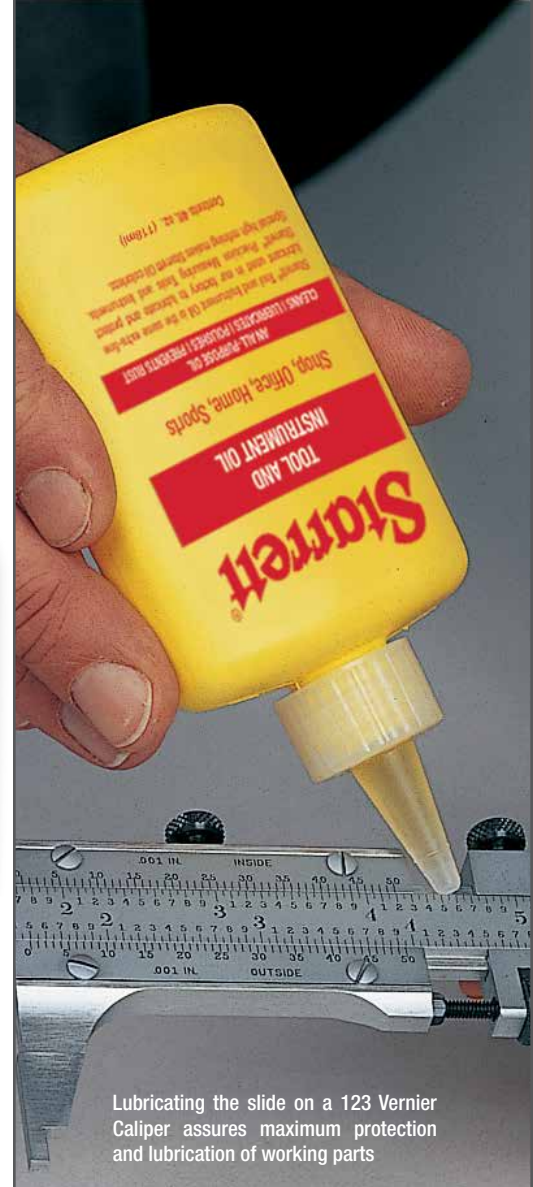

Lubricating the slide on a 123 Vernier Caliper assures maximum protection and lubrication of working parts

1620 Tool and Instrument Oil

| Cat. No. | EDP | Description |
|----------|-------|--------------------------------------|
| 1620 | 53216 | 4 fl. oz. (0.1 liter) plastic bottle |

706 INSPECTION BLOCKS

1 X 2 X 3"

706M INSPECTION BLOCKS

25 X 50 X 75MM

These Inspection Blocks are manufactured to precision tolerances, and are of great value for all inspection laboratories and in-shop setups where positioning is important.

- High accuracy
- Hardened steel, ground and lapped
- Matched pair available

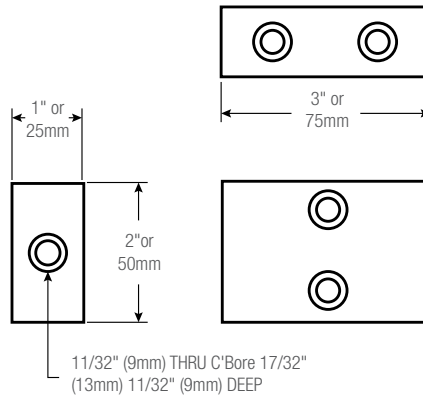

706BZ

Inch Blocks

| Cat. No. | EDP | Description |
|----------|-------|---------------------------------|
| 706AZ | 57121 | Single 1 x 2 x 3" block in case |
| 706BZ | 57122 | Matched pair in case |

Millimeter Blocks

| Cat. No. | EDP | Description |
|----------|-------|-------------------------------------|
| 706MAZ | 64968 | Single 25 x 50 x 75mm block in case |
| 706MBZ | 64969 | Matched pair in case |

Specifications

| | |
|------------------|-----------------------------|
| Block Dimensions | 1 x 2 x 3" (25 x 50 x 75mm) |
| Parallelism | .0001" (0.003mm) |
| Squareness | .0001 in/in (0.003mm/25mm) |
| Hardness | RC 63-65 |
| Flatness | .0001" (0.003mm) |



DIGITAL TACHOMETER

S7793Z CONTACT AND NON-CONTACT DIGITAL TACHOMETER

This Pocket Laser Tachometer (S7793Z) is a digital, battery-powered portable optical tachometer that can operate up to 25 feet from a reflective target using a laser light source. Its ergonomic design allows safe, direct line-of-sight viewing of both target and display at the same time, with a non-slip rubber surface for single hand operation.

MULTI-FUNCTION

This powerful 32 function Tachometer/Ratemeter, Totalizer/Counter and Timer (stopwatch) is programmable in both inch and metric rates. It has TTL compatible pulse output to trigger devices such as data collectors or stroboscopes.

The kit is supplied with a remote contact assembly including concave and convex tips, a 10cm linear speed wheel, and rugged carrying case.

FEATURES

- Operating range up to 25 feet* (Class 3R visible laser)
- Accepts remote contact assembly
- Accepts remote sensors (optional)
- TTL pulse output
- Auto ranging/fixed decimal (user selectable)
- English and metric rates
- Tripod mounting bushing
- On-target and low battery indicators
- Rugged rubberized housing
- NIST traceable certificate of calibration included



Kit includes tachometer, RCA, contact tips, 10cm linear contact wheel 5 feet of T-5 reflective tape, (2) "AA" batteries, and latching carrying case



The S7793Z Pocket Laser Tachometer can operate with the remote contact assembly (left) or up to 25 feet from a reflective target (right)

| 7793 Contact and Non-Contact Digital Tachometer | | |
|---|-------|--|
| Cat. No. | EDP | Description |
| S7793Z | 68930 | Tachometer, RCA, contact tips, 10cm linear contact wheel 5' of T-5 reflective tape, (2) "AA" batteries, latching carrying case |

| Specifications | |
|---|---|
| Display | 5 Alpha-Numeric LCD |
| Ranges | |
| Optical* | 5-200,000 RPM |
| Contact** | 0.5-20,000 RPM |
| Rates 10cm Circumference Contact Wheel | |
| Inches/Min | 1.969-78,740 |
| Feet/Min | 0.164-6,561.7 |
| Yards/Min | 0.055-2,187.2 |
| Centimeters/Min | 5.000-200,000 |
| Meters/Min | 0.050-2,000 |
| Totalizer | 1-200,000 |
| Accuracy | |
| Optical | ±0.01% of reading |
| Contact | ±0.05% of reading (rpm) |
| Resolution | 0.001-10 RPM |
| Operating range | 2 Inches to 25 feet, ±70° |
| Memory | Maximum, Minimum, and Last |
| Power | (2) "AA" 1.5 VDC Batteries (30 Hours) |
| Environmental | 5° - 40°C (0° - 100°F) 80% RH up to 31°C (88°F) |
| Size (H x W x D) | 6.92 x 2.4 x 1.6" (176 x 61 x 41mm) |
| Weight | 7 oz. (210g) |

* Performance subject to intensity of ambient light irradiation

** Also reads units per second and per hour





PRECISION MAKES THE DIFFERENCE

IT IS TIME TO UPGRADE YOUR COMBINATION SQUARE?

Starrett combination squares provide the durability and dependability needed for years of unparalleled accuracy and usefulness.

Whether measuring depth, height, angles for miter cuts or using the steel rule as precision straight edge, the Starrett combination square replaces an assortment of single-use tools.

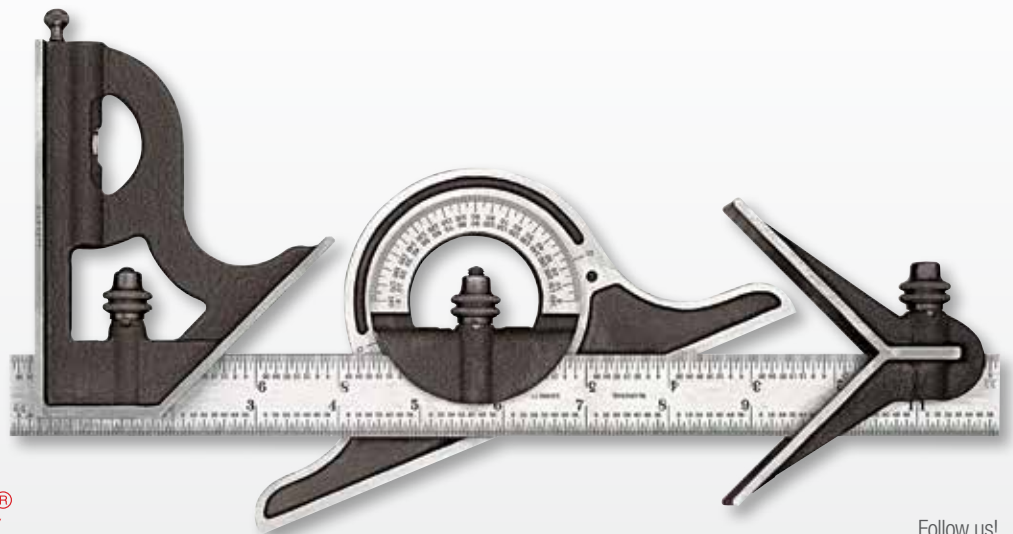

Starrett®

(978) 249-3551 • starrett.com

Follow us!



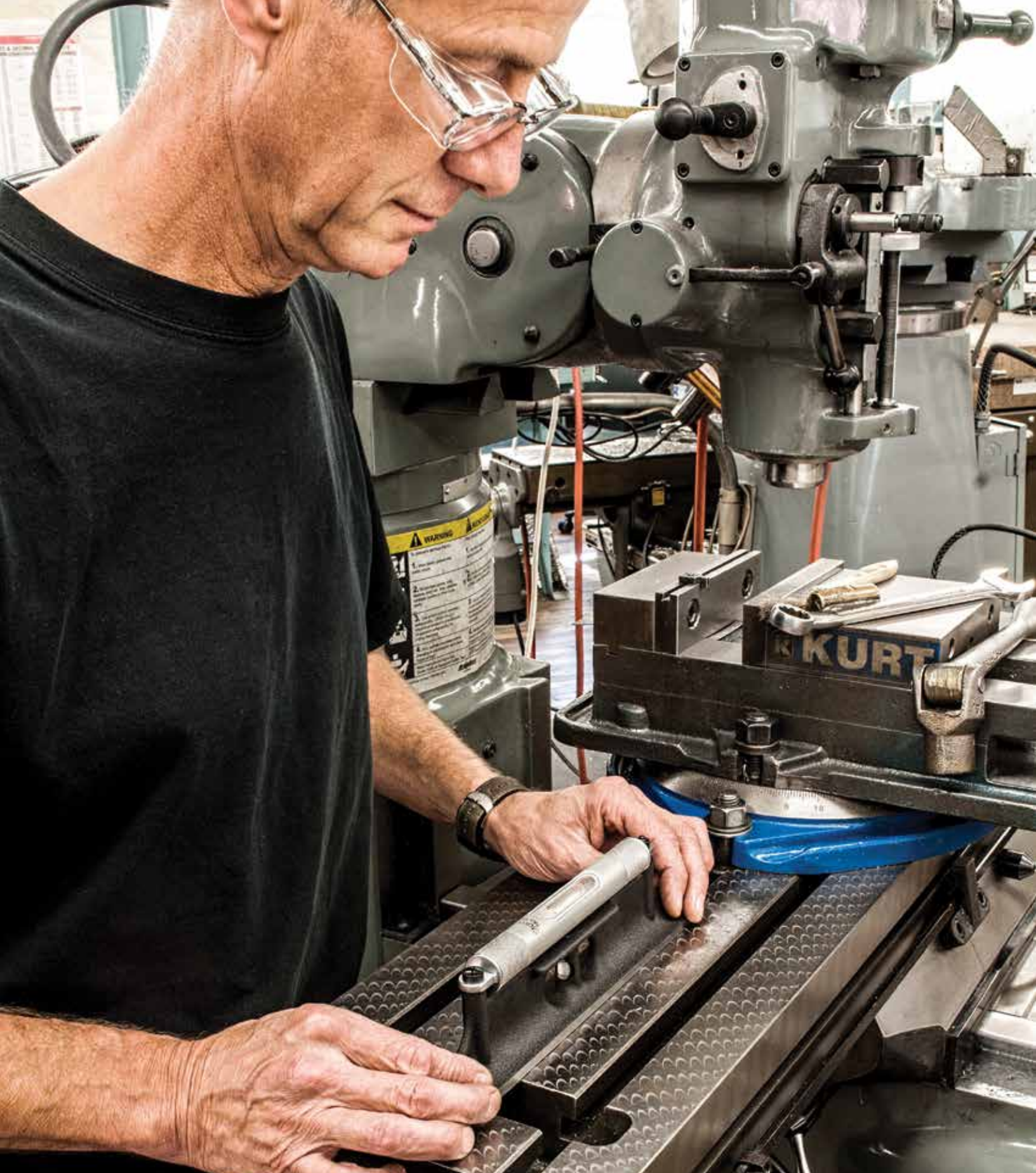

MACHINISTS' LEVELS

MASTER PRECISION LEVELS

199 MASTER PRECISION LEVEL

15"/380MM

The efficiency of modern, high speed machinery depends to a large degree upon the levelness of the machine set-up.

- Specially designed to set up, check and test machinery of all types
- At-a-glance reading of the exact variation of machinery levelness
- Ground and graduated main vial of 10-second accuracy; one division equals 1/2 thousandth of an inch (0.0005") per foot, or 0.04mm per meter
- Main vials have seven graduations on each side of the bubble
- Auxiliary level vial shows lateral position and assists in horizontal setting
- Level vials are positioned so breakage is reduced to a minimum
- Special alloy iron used to obtain freedom from thermal effects
- Seasoned, machined castings
- Scraped reference surface
- Nonconductive top plate and black wrinkle finish on nonmachined surfaces
- Finished wood case



| 199 Master Precision Level | | | | | | | |
|----------------------------|-------|-------------|-----|------------|----|--------------|----|
| Cat. No. | EDP | Length Base | | Width Base | | Height Level | |
| | | in | mm | in | mm | in | mm |
| 199Z | 50719 | 15 | 380 | 1-5/8 | 40 | 3 | 75 |
| 199Z W/SLC* | 66932 | | | | | | |

* Includes redemption card for Standard Letter of Certification (SLC).

LEVEL USE

To get a correct reading with a level, both ends of the bubble should be viewed. If the gaps between the ends of the bubble and the lines are unequal at any time, then they should be averaged out. The reason for this is temperature, which affects the size of the bubble. As a level is warmed the liquid expands, thereby reducing the size of the bubble so that at true-level there will be gaps at both ends between the bubble and the reading lines. Conversely, if the temperature is very cold, the bubble could expand and overlap the reading lines.

Excessive hand heat on the center of the level for an extended period of time could expand the center, causing the working surface to become slightly convex and also create a tendency to spin on flat surfaces. This is more noticeable on very precise levels.

Any level can be checked for accuracy on any flat surface regardless of whether it is level or not. Simply put the level on the surface and note the position of the bubble. Then reverse the level in the same spot. If the level is true, the bubble will be in the same relative position both ways.

Some models, like our 98 machinist levels with an adjustable system, have an adjustment that can be made on the job.

LEVEL VIAL INFORMATION

The accuracy of a level is dependent on the proper machining of the working surface, the straightness, and rigidity of the construction and the sensitivity of the level vial. Accuracies are very often specified in parts of degrees such as 10-second accuracy or 43-minute accuracy. Technically, we are referring to the sensitivity of the level vial, but many interchange these terms. Since this means little to most people, we use the more practical definition of inches per foot of elevation. For instance, a 10-second vial accuracy means if the level is on an incline that is .0005" per foot, then the bubble on the vial will move .100" (slightly less than 1/8").

There are three general types of level vials. Ground vials are generally used in precision levels; bent glass and plastic vials are used in most other levels.

Most level vials have just two lines spanning the length of the bubble because most users just want to know if something is level or not.

The more precise levels have vials with a number of reading lines on each side of the bubble. All Inch reading vial graduations are .100" apart. This will show the machinist in a very precise manner how level the equipment is.

Metric reading levels have vial graduations 2mm apart and accuracies are usually described as millimeters per meter. This is an easy conversion to make, so we converted our Inch specifications to an understandable metric reading. Machinists only need to know how far they are out of level if the bubble moves to the next line.

199, 98 AND 132 PRECISION MACHINISTS' LEVELS

These are the finest levels available, used for precision work that is typically required in the industry. They all have these features:

- All level bases are made from the finest quality seasoned cast iron and are precision-machined on the reference surface
- Non-machined surfaces have an attractive, black wrinkle finish
- All models except the 199 have an involute longitudinal groove between the bearing flats for accurate seating on round work. This groove has a special involute design, permitting better centering and greater capacity to handle larger rounds
- Groove and bearing flats are machined together for maximum accuracy

MACHINISTS' LEVELS

98 MACHINISTS' LEVELS WITH GROUND AND GRADUATED VIALS

4-18"/100-450MM

These levels have ground and graduated main vials. All sizes have a cross test vial except the 4" (100mm) model.

The 12" (300mm) model also has a plumb vial and the 18" (450mm) size has a double plumb vial.

These vials are adjustable to a positive setting and are housed in a satin chrome finished brass tube with a friction-fit closing cover to prevent breakage.

The base of the levels features an involute groove running the length of the base, which provides a reliable seat for round work such as pipes or shafting.

With the cross test vial, it is possible to simultaneously level in both directions. This prevents inaccuracies in the main vial reading caused by canting the level sidewise on round work.

The 6" through 18" (150-450mm) main level vials have graduations that are approximately 80-90 seconds or .005" per foot (0.42mm per meter). There are five, six, or seven lines on each side of the bubble, depending on the base length.



End view showing involute groove



98 Machinists' Levels with Ground and Graduated Vials

| Without Case | | In Finished Wood Case | | Tube and Plug Assemblies | | Size | | Description |
|--------------|-------|-----------------------|-------|--------------------------|-------|------|-----|---|
| Cat. No. | EDP | Cat. No. | EDP | Part No. | EDP | in | mm | |
| 98-4 | 50440 | | | | | 4 | 100 | Without cross test vial |
| 98-6 | 50441 | | | | | | | With cross test vial |
| 98-6 W/SLC | 66935 | | | PT99430 | 64497 | 6 | 150 | With cross test vial, Standard Letter of Certification* |
| 98-8 | 50442 | | | PT99431 | 64498 | 8 | 200 | With cross test vial |
| 98-12 | 50443 | 98Z-12 | 50444 | PT99432 | 64499 | | | With single plumb vial and cross test vial |
| 98-12 W/SLC | 66934 | 98Z-12 W/SLC | 66933 | | | 12 | 300 | With single plumb vial and cross test vial, Standard Letter of Certification* |
| 98-18 | 50445 | 98Z-18 | 50446 | | | 18 | 450 | With double plumb vial and cross test vial |

To guarantee extreme accuracy, the length of your level should not be longer than the work you are leveling.

* Includes redemption card for Standard Letter of Certification (SLC)



PRECISION BENCH LEVELS

132 PRECISION BENCH LEVELS WITH DOUBLE PLUMBS

6-24"/150-600MM

These are moderately priced levels designed for the all-around use of machinists, maintenance and set-up mechanics and carpenters. They are available in a wide range of sizes to suit every requirement.

- The attractive filigree design of these levels provides a lighter weight, and the curved design evenly dissipates excess heat
- The base of the levels has an involute groove running the full length, which provides a reliable seat for round work
- All sizes have a main vial and double plumb vials. Each vial has two graduated lines
- The main vials have approximately 19-minute sensitivity, meaning if the bubble moves 1/8" off the graduated lines, the out-of-level is approximately .080" per foot. If the bubble is off 2mm, then the out-of-level is approximately 4.4mm per meter.

| 132 Precision Bench Levels | | | | |
|----------------------------|-------|------------|-----|--------------------------------------|
| Cat. No. | EDP | Size in | mm | Description |
| 132-6 | 50562 | 6 | 150 | With main vial and double plumb vial |
| 132-9 | 50563 | 9 | 225 | |
| 132-12 | 50564 | 12 | 300 | |
| 132-24 | 50566 | 24 | 600 | |

To guarantee extreme accuracy, the length of your level should not be longer than the work you are leveling.



End view showing involute groove



132-12

CROSS TEST LEVELS

134 CROSS TEST LEVEL AND PLUMB

2 X 3"/50 X 75MM

This is an especially useful little level, invaluable for plumbing, approximate squaring and leveling work. Made from brass with nickel finish, all working surfaces are flat and true. The level has two vials at right angles for cross test leveling without moving the tool and a plumb level at the top. An accurate, well-made and reliable tool, it is also very light and compact and can be easily carried in the pocket.



MACHINISTS' LEVELS

134 Cross Test Level

| Cat. No. | EDP | Size in | mm | Description |
|----------|-------|---------|---------|--------------------------------------|
| 134 | 50569 | 2 x 3 | 50 x 75 | With cross test vials and plumb vial |

136 CROSS TEST LEVEL

2-3/4 X 2-3/4"/70 X 70MM

Similar to our 134 level, the 136 has two vials at right angles which permit leveling in both directions without moving the level from the work. The level is light and compact, with an attractive black wrinkle finish and a ground reference surface. Made from cast iron.

136 Cross Test Level

| Cat. No. | EDP | Size in | mm | Description |
|----------|-------|---------------|---------|-----------------------|
| 136 | 50572 | 2-3/4 x 2-3/4 | 70 x 70 | With cross test vials |



MACHINISTS' LEVELS

130 BENCH LEVEL

3-3/8"/85MM

This is a very handy, compact bench level with a sensitive and accurate single vial. The body is made of seasoned cast iron with black wrinkle finish and an accurately machined base leveling surface.

| 130 Bench Level | | | | |
|-----------------|-------|---------|----|----------------|
| Cat. No. | EDP | Size in | mm | Description |
| 130 | 50560 | 3-3/8 | 85 | With main vial |



130



135B

135 POCKET LEVELS WITH SATIN NICKEL-PLATED FINISH

2-1/2 AND 3-1/2"/63 AND 88MM

Another extremely useful Starrett level that fits handily in the pocket with no sharp edges. Made from hexagonal stock with convex ends and satin nickel-plated finish.

| 135 Pocket Levels with Satin Nickel-Plated Finish | | | | |
|---|-------|---------|----|----------------|
| Cat. No. | EDP | Size in | mm | Description |
| 135A | 50570 | 2-1/2 | 63 | With main vial |
| 135B | 50571 | 3-1/2 | 88 | With main vial |





STARRETT-WEBBER GAGE BLOCKS

PRECISION GAGE BLOCKS, STANDARD REFERENCE BARS

GAGE BLOCKS – MAJOR PRODUCT CHARACTERISTICS

Precision gage blocks are the primary standards vital to dimensional quality control in the manufacture of parts. The four major characteristics that are necessary for a precision gage block are accuracy, surface finish, wear resistance and dimensional stability. Other factors are corrosion resistance, hardness, thermal conductivity and coefficient of expansion.

The base material used for gage blocks is crucial in meeting the above criteria. While many materials have been tried, the major types available today are:

- **Traditional high-grade steel** gage blocks, which are generally used in shop floor environments
- **Tungsten Carbide** gage blocks, which have the advantage of being harder and longer wearing than steel (Not available from Starrett-Webber)
- **Ceramic** gage blocks will outwear regular steel and will not corrode
- **Chromium Carbide** gage blocks are considered the top of the line; the finest available. They outwear regular steel and ceramic. In addition, they will not corrode, are very stable and accurate, and have exceptional "wringing" qualities.

crobox® Chromium Carbide is the superior gage block material. The reason that our Webber Gage Division emphasizes gage blocks made from Chromium Carbide is because they are the most stable measuring devices ever developed.

No one in the world except Starrett-Webber has produced the accuracy and stability of our crobox Grand Masters. They were produced in 1955 of Chromium Carbide material to an accuracy within one millionth of an inch (.0000254mm) and have been checked periodically by the U.S. National Bureau of Standards and the U.S. National Institute of Standards and Technology (NIST) and have remained stable over this period.

OTHER CHARACTERISTICS

ACCURACY

All Starrett-Webber gage blocks meet or exceed all known specifications. The flatness, parallelism and surface finish necessary to achieve the required accuracies are the same as or better than government requirements.

STABILITY

Starrett-Webber gage blocks do not change in size except through normal wear. Gage block stability is a characteristic that our Webber Gage Division has mastered with over eighty years of experience. Our gage blocks withstand the test of time.

HARDNESS

Steel blocks have a Rockwell "C" hardness of approximately 64-65. Chromium Carbide blocks have a Rockwell "C" hardness of 71-73, with an unusually fine, hard grain structure, giving them exceptional resistance to wear and abrasion.

THERMAL CONDUCTIVITY AND COEFFICIENT OF EXPANSION

These are not important considerations when measurements are taken in temperature-controlled environments. This is primarily done when measuring to microinches or microns.

On the shop floor, where precision measurements are rarely finer than .0002" or 0.005mm, the coefficient of expansion of steel, chromium carbide and ceramic is so close as to be negligible.

Thermal conductivity is important on the shop floor. However, because it takes time for a gage block to move to the same temperature as the workpiece, we recommend setting the gage block on a heat sink such as a large mass of metal that is at the shop environment temperature.



HOW TO ORDER STARRETT PRECISION GAGE BLOCKS

GAGE BLOCK SETS

1. Order by catalog number.
2. Please specify if you require a Commercial Calibration or Master Calibration. See the catalog page regarding our Accredited Gage Block Calibration Service near the end of this section. A certificate of calibration provides individual readings on each block and provides traceability to NIST. Webber gage block calibrations are NVLAP® accredited by NIST. (We require the end user's name and address to place on the certificate.)
3. Specify if you require special etched serial numbers. We can provide numbers up to a 6-digit maximum. (Our standard practice is to put the same etch number on each block in a set. Blocks are differentiated by their marked size.) If an etched serial number is not specified, we will assign a number that is a coded date.

The buyer of Webber products listed in this catalog agrees to the 100% Relaxed Acceptance Rule contained in ASME B89.7.3.1 (Guidelines for Decision Rules: Considering Measurement Uncertainty in Determining Conformance to Specifications). Products may not be rejected by the purchaser unless his measurements exceed the published tolerances by more than his uncertainty of measurement.

NVLAP® accreditation does not constitute an endorsement of any product by NVLAP® or any agency of the U.S. government.



NVLAP LAB CODE 200038-0

National Institute of Standards and Technology
National Voluntary Laboratory Accreditation Program



STARRETT-WEBBER GAGE DIVISION

24500 Detroit Road
Cleveland, OH 44145
Phone: 440-835-0001
Fax: 440-892-9555
E-mail: sales@starrett-webber.com

DIMENSIONAL NVLAP Code: 20/D03 Gage Blocks

INDIVIDUAL GAGE BLOCKS

1. **Specify Shape**, signified by the following symbols:

- Rectangular 
- Square 
- Heavy Duty 

2. **Specify Material** (croblox®, steel, or ceramic)
3. **Specify Unit of Measure** (inch or metric)
4. **Specify the Size**
5. **Specify Special Lengths**, if applicable (Rectangular Only)

- Thin block sets (28 pc. inch and 17 pc. metric) are all 1.115" (28.3mm) long. Specify "SS" length.
- .050", .100", and .150" blocks in inch 81-92 pc. sets are 1.380" long. Specify the Long length, "L".
- .100" blocks contained in the 36, 38, and 43 pc. sets are 1.380" long. Specify the Long length, "L".

6. **Specify Accuracy Grade** (see next page)

7. **Specify if you require a Commercial, Master or Laboratory Calibration***. See the catalog page regarding our Accredited Gage Block Calibration Service near the end of this section. A certificate of calibration provides individual readings on each block and provides traceability to NIST. Webber gage block calibrations are NVLAP® accredited by NIST. (We require the end user's name and address to place on the certificate.)

* Commercial calibrations are included in the price of gage blocks. Master calibrations are done at extra cost. Laboratory calibrations are done at extra cost and are restricted to Webber croblox® rectangular style gage blocks of grades LM, AA, GGG grades 0.5 and 1, and B89 Grades 00 and K.

8. **Specify if you require special etched serial numbers.** We can provide up to a 6-digit maximum. If an etched serial number is not specified, we will assign a number that is a coded date.



GAGE BLOCK TOLERANCES

GAGE BLOCK TOLERANCES: B89.1.9

| Inch System: Tolerances expressed in microinches (.00001") 1 millionth of an inch | | | | | | | | | |
|---|-----------------------|-------------------------------|--------------------|--|-------------------------------|--------------------|---------------------------------------|-------------------------------|--------------------|
| | Order Webber Grade LM | | | Order Webber Grade AA B89.1.9 Grade 00 | | | Order Webber Grade A1 B89.1.9 Grade 0 | | |
| | Size Tolerance | Variation in Length Tolerance | Flatness Tolerance | Size Tolerance | Variation in Length Tolerance | Flatness Tolerance | Size Tolerance | Variation in Length Tolerance | Flatness Tolerance |
| Thru .050" | +1.2/-1.2 | 1.2 | 1.2 | +4/-4 | 2 | 2 | +6/-6 | 4 | 4 |
| Thru .400" | +1.2/-1.2 | 1.2 | 1.2 | +3/-3 | 2 | 2 | +5/-5 | 4 | 4 |
| Thru 1" | +1.2/-1.2 | 1.2 | 1.2 | +3/-3 | 2 | 2 | +6/-6 | 4 | 4 |
| Thru 2" | +2.0/-2.0 | 1.2 | 1.2 | +4/-4 | 2 | 2 | +8/-8 | 4 | 4 |
| Thru 3" | +3.0/-3.0 | 1.2 | 1.2 | +5/-5 | 3 | Rect.: 2, Sq.: 3 | +10/-10 | 4 | 4 |
| Thru 4" | +4.0/-4.0 | 1.2 | 1.2 | +6/-6 | 3 | Rect.: 2, Sq.: 3 | +12/-12 | 5 | 4 |
| Thru 5" | | | | +8/-8 | 3 | Rect.: 2, Sq.: 3 | +16/-16 | 5 | 4 |
| Thru 6" | | | | +8/-8 | 3 | Rect.: 2, Sq.: 3 | +16/-16 | 5 | 4 |
| Thru 7" | | | | +10/-10 | 4 | 4 | +20/-20 | 6 | 6 |
| Thru 8" | | | | +10/-10 | 4 | 4 | +20/-20 | 6 | 6 |
| Thru 10" | | | | +12/-12 | 4 | 4 | +24/-24 | 6 | 6 |
| Thru 12" | | | | +14/-14 | 4 | 4 | +28/-28 | 7 | 6 |
| Thru 16" | | | | +18/-18 | 5 | 4 | +36/-36 | 8 | 6 |
| Thru 28" | | | | +20/-20 | 6 | 4 | +44/-44 | 10 | 6 |

| Not Available from Webber B89.1.9 Grade AS1 | | | Not Available from Webber B89.1.9 Grade AS2 | | |
|---|-------------------------------|--------------------|---|-------------------------------|--------------------|
| Size Tolerance | Variation in Length Tolerance | Flatness Tolerance | Size Tolerance | Variation in Length Tolerance | Flatness Tolerance |
| Thru .050" | +12/-12 | 6 | +24/-24 | 12 | 10 |
| Thru .400" | +8/-8 | 6 | +18/-18 | 12 | 10 |
| Thru 1" | +12/-12 | 6 | +24/-24 | 12 | 10 |
| Thru 2" | +16/-16 | 6 | +32/-32 | 12 | 10 |
| Thru 3" | +20/-20 | 6 | +40/-40 | 14 | 10 |
| Thru 4" | +24/-24 | 8 | +48/-48 | 14 | 10 |
| Thru 5" | +32/-32 | 8 | +64/-64 | 16 | 10 |
| Thru 6" | +32/-32 | 8 | +64/-64 | 16 | 10 |
| Thru 7" | +40/-40 | 10 | +80/-80 | 16 | 10 |
| Thru 8" | +40/-40 | 10 | +80/-80 | 16 | 10 |
| Thru 10" | +48/-48 | 10 | +104/-104 | 18 | 10 |
| Thru 12" | +56/-56 | 10 | +112/-112 | 20 | 10 |
| Thru 16" | +72/-72 | 12 | +144/-144 | 20 | 10 |
| Thru 20" | +88/-88 | 14 | +176/-176 | 24 | 10 |

B89.1.9 Grade 00 exceeds DIN, ISO, BS Grades K

Material Coefficients of Thermal Expansion are:
 Chromium Carbide 4.7 x 10⁻⁶ inch/°F per inch
 SAE 52100 Steel 6.4 x 10⁻⁶ inch/°F per inch
 Ceramic 5.5 x 10⁻⁶ inch/°F per inch

| Suggested Replacement Grades for GGG-G-15C | | |
|--|--------------|---------------|
| GGG-G-15C Grade | Webber Grade | B89.1.9 Grade |
| 0.5 | LM | — |
| 1 | AA | 0 |
| 2 | A1 | 0 |
| 3 | A | AS1 |

The above replacement grades are suggested in B89.1.9. However, the tolerances specified in GGG-G-15C and B89.1.9 are not exactly the same. Gage blocks meeting B89.1.9 specifications may not meet GGG-G-15C requirements and vice versa.



| Metric System: Tolerances expressed in micrometers (0.001mm) | | | | | | | | | |
|--|-----------------------|-------------------------------|--------------------|---------------------------------------|-------------------------------|-----------------------|--|-------------------------------|--------------------|
| | Order Webber Grade LM | | | Order Webber Grade A1 B89.1.9 Grade 0 | | | Order Webber Grade AA B89.1.9 Grade 00 | | |
| | Size Tolerance | Variation in Length Tolerance | Flatness Tolerance | Size Tolerance | Variation in Length Tolerance | Flatness Tolerance | Size Tolerance | Variation in Length Tolerance | Flatness Tolerance |
| Thru 0.5mm | +03/-03 | .03 | .03 | +10/-10 | .05 | .05 | +14/-14 | .10 | .10 |
| Thru 10mm | +03/-03 | .03 | .03 | +07/-07 | .05 | .05 | +12/-12 | .10 | .10 |
| Thru 25mm | +04/-04 | .03 | .03 | +07/-07 | .05 | .05 | +14/-14 | .10 | .10 |
| Thru 50mm | +05/-05 | .03 | .03 | +10/-10 | .06 | .05 | +20/-20 | .10 | .10 |
| Thru 75mm | +08/-08 | .03 | .03 | +12/-12 | .07 | Rect (.05), Sq. (.07) | +25/-25 | .12 | .10 |
| Thru 100mm | +10/-10 | .03 | .03 | +15/-15 | .07 | Rect (.05), Sq. (.07) | +30/-30 | .12 | .10 |
| Thru 125mm | | | | +20/-20 | .08 | Rect (.05), Sq. (.07) | +40/-40 | .14 | .10 |
| Thru 150mm | | | | +20/-20 | .08 | Rect (.05), Sq. (.07) | +40/-40 | .14 | .10 |
| Thru 175mm | | | | +25/-25 | .09 | .10 | +50/-50 | .16 | .15 |
| Thru 200mm | | | | +25/-25 | .09 | .10 | +50/-50 | .16 | .15 |
| Thru 250mm | | | | +30/-30 | .10 | .10 | +60/-60 | .16 | .15 |
| Thru 300mm | | | | +35/-35 | .10 | .10 | +70/-70 | .18 | .15 |
| Thru 400mm | | | | +45/-45 | .12 | .10 | +90/-90 | .20 | .15 |
| Thru 500mm | | | | +50/-50 | .14 | .10 | +1.1/-1.1 | .25 | .15 |

| | Not Available from Webber B89.1.9 Grade AS1 | | | Not Available from Webber B89.1.9 Grade AS2 | | |
|------------|---|-------------------------------|--------------------|---|-------------------------------|--------------------|
| | Size Tolerance | Variation in Length Tolerance | Flatness Tolerance | Size Tolerance | Variation in Length Tolerance | Flatness Tolerance |
| Thru 0.5mm | +30/-30 | .16 | .15 | +60/-60 | .30 | .25 |
| Thru 10mm | +20/-20 | .16 | .15 | +45/-45 | .30 | .25 |
| Thru 25mm | +30/-30 | .16 | .15 | +60/-60 | .30 | .25 |
| Thru 50mm | +40/-40 | .18 | .15 | +80/-80 | .30 | .25 |
| Thru 75mm | +50/-50 | .18 | .15 | +1.0/-1.0 | .35 | .25 |
| Thru 100mm | +60/-60 | .20 | .15 | +1.2/-1.2 | .35 | .25 |
| Thru 125mm | +80/-80 | .20 | .15 | +1.6/-1.6 | .40 | .25 |
| Thru 150mm | +80/-80 | .20 | .15 | +1.6/-1.6 | .40 | .25 |
| Thru 175mm | +1.0/-1.0 | .25 | .18 | +2.0/-2.0 | .40 | .25 |
| Thru 200mm | +1.0/-1.0 | .25 | .18 | +2.0/-2.0 | .40 | .25 |
| Thru 250mm | +1.2/-1.2 | .25 | .18 | +2.4/-2.4 | .45 | .25 |
| Thru 300mm | +1.4/-1.4 | .25 | .18 | +2.8/-2.8 | .50 | .25 |
| Thru 400mm | +1.8/-1.8 | .30 | .18 | +3.6/-3.6 | .50 | .25 |
| Thru 500mm | +2.2/-2.2 | .35 | .18 | +4.4/-4.4 | .60 | .25 |

Material Coefficients of Thermal Expansion are:
 Chromium Carbide 8.5×10^{-6} m/°C per m
 SAE 52100 Steel 11.5×10^{-6} m/°C per m
 Ceramic 9.9×10^{-6} m/°C per m

B89.1.9 Grade 00 exceeds DIN, ISO, BS Grades K

| Suggested Replacement Grades for GGG-G-15C | | |
|--|--------------|---------------|
| GGG-G-15C Grade | Webber Grade | B89.1.9 Grade |
| 0.5 | LM | — |
| 1 | AA | 0 |
| 2 | A1 | 0 |
| 3 | A | AS1 |

The above replacement grades are suggested in B89.1.9. However, the tolerances specified in GGG-G-15C and B89.1.9 are not exactly the same. Gage blocks meeting B89.1.9 specifications may not meet GGG-G-15C requirements and vice versa.



GAGE BLOCK SETS

RECTANGULAR INCH SYSTEM GAGE BLOCK SETS, INDIVIDUAL BLOCKS AND ACCESSORIES



All sets are furnished in a handsome, rugged wood case for lasting protection

INCH

| Rectangular croblox® Gage Block Sets in Case | | | | |
|--|--------------------------------------|--|----------------|--|
| Cat. No. | Accuracy Grade* | Measuring Range | Blocks Per Set | Blocks Included In Sets |
| RC 81.A1 RC 81.AA RC 81.LM** | B89.1.9 0 B89.1.9 00 Webber LM | .100-12.000 in Steps of .001 .200-12.000 in Steps of .0001 | 81 | 9 Blocks .1001 Through .1009 (Steps of .0001) 49 Blocks .101 Through .149 (Steps of .001) 19 Blocks .050 Through .950 (Steps of .050) 4 Blocks 1.000 Through 4.000 (Steps of 1") |
| RC 88.A1 RC 88.AA RC 88.LM** | B89.1.9 0 B89.1.9 00 Webber LM | .100-12.000 in Steps of .001 .200-12.000 in Steps of .0001 .300-12.000 in Steps of .000025 1/16-12.000 in Steps of 1/64 | 88 | Same as in RC 81. Set, Plus 3 Blocks .100025, .10005, .100075 4 Blocks 1/16, 5/64, 3/32, 7/64 |
| RC 34.A1 RC 34.AA RC 34.LM** | B89.1.9 0 B89.1.9 00 Webber LM | .200-8.000 in Steps of .001 .300-8.000 in Steps of .0001 | 34 | 9 Blocks .1001 Through .1009 (Steps of .0001) 9 Blocks .101 Through .109 (Steps of .001) 9 Blocks .110 Through .190 (Steps of .010) 3 Blocks .100 Through .300 (Steps of .100) 1 Block .500 3 Blocks 1.000, 2.000 and 4.000 |
| RC 28.A1 RC 28.AA | B89.1.9 0 B89.1.9 00 | .020-.240 in Steps of .001 .040-.240 in Steps of .0001 .060-.240 in Steps of .00005 | 28 | 1 Block .02005 9 Blocks .0201 Through .0209 (Steps of .0001) 9 Blocks .021 Through .029 (Steps of .001) 9 Blocks .010 Through .090 (Steps of .010) |

For gage block accessories, order AC 11.A Accessory Set in Case. Sets include etched serial numbers and Commercial Calibration Certificate. A Master Calibration Certificate is available at extra cost.

* For complete accuracy specifications, see the beginning of this section.

** Available by special order only.



GAGE BLOCK SETS

RECTANGULAR INCH SYSTEM GAGE BLOCK SETS, INDIVIDUAL BLOCKS AND ACCESSORIES

Our Ceramic Gage Blocks, offered in rectangular, inch and metric, fill the gap between steel and the universally accepted croblox®. While not as stable as croblox®, ceramic is an excellent alternative to steel because of its superior hardness, thermal expansion and wear characteristics.

INCH

| Rectangular Ceramic Gage Block Sets in Case | | | | |
|---|-------------------------|--|----------------|---|
| Cat. No. | Accuracy Grade* | Measuring Range | Blocks Per Set | Blocks Included In Sets |
| RY 81.A1 RY 81.AA | B89.1.9 0 B89.1.9 00 | .100-12.000 in Steps of .001 .200-12.000 in Steps of .0001 | 81 | 9 Blocks .1001 Through .1009 (Steps of .0001) 49 Blocks .101 Through .149 (Steps of .001) 19 Blocks .050 Through .950 (Steps of .050) 4 Blocks 1.000 Through 4.000 (Steps of 1") |
| RY 88.A1 RY 88.AA | B89.1.9 0 B89.1.9 00 | .100-12.000 in Steps of .001 .200-12.000 in Steps of .0001 .300-12.000 in Steps of .000025 1/16-12.000 in Steps of 1/64 | 88 | Same as in RY 81. Set, Plus 3 Blocks .100025, .10005, .100075 4 Blocks 1/16, 5/64, 3/32, 7/64 |
| RY 34.A1 RY 34.AA | B89.1.9 0 B89.1.9 00 | .200-8.000 in Steps of .001 .300-8.000 in Steps of .0001 | 34 | 9 Blocks .1001 Through .1009 (Steps of .0001) 9 Blocks .101 Through .109 (Steps of .001) 9 Blocks .110 Through .190 (Steps of .010) 3 Blocks .100 Through .300 (Steps of .100) 1 Block .500 3 Blocks 1.000, 2.000 and 4.000 |

Sets include etched serial number and Commercial Calibration Certificate. A Master Calibration Certificate is available at extra cost.

* For complete accuracy specifications, see the beginning of this section.

INCH

| Rectangular Steel Gage Block Sets in Case | | | B89.1.9 Accuracy Grade 0* |
|---|--|----------------|--|
| Cat. No. | Measuring Range | Blocks Per Set | Blocks Included In Sets |
| RS 81.A1 | .100-12.000 in Steps of .001 .200-12.000 in Steps of .0001 | 81 | 9 Blocks .1001 Through .1009 (Steps of .0001) 49 Blocks .101 Through .149 (Steps of .001) 19 Blocks .050 Through .950 (Steps of .050) 4 Blocks 1.000 Through 4.000 (Steps of 1") |
| RS 88.A1 | .100-12.000 in Steps of .001 .200-12.000 in Steps of .0001 .300-12.000 in Steps of .000025 1/16-12.000 in Steps of 1/64 | 88 | Same as in RS 81.A1 Set, Plus 3 Blocks .100025, .10005, .100075 4 Blocks 1/16, 5/64, 3/32, 7/64 |
| RS 92.A1 | .100-12.000 in Steps of .001 .200-12.000 in Steps of .0001 .300-12.000 in Steps of .000025 1/16-12.000 in Steps of 1/64 | 92 | Same as in RS 88.A1 Set, Plus 2 Blocks .100" (croblox® Wear Blocks) 2 Blocks .050 (croblox® Wear Blocks) |
| RS 38.A1 | .100-4.000 in Steps of .001 .150-4.000 in Steps of .0001 .200-4.000 in Steps of .00005 | 38 | 2 Blocks .050 (croblox® Wear Blocks) 1 Block .05005 9 Blocks .0501 Through .0509 (Steps of .0001) 9 Blocks .051 Through .059 (Steps of .001) 11 Blocks .050 Through .150 (Steps of .010) 4 Blocks .200 Through .500 (Steps of .100) 2 Blocks 1.000 and 2.000 |
| RS 34.A1 | .200-8.000 in Steps of .001 .300-8.000 in Steps of .0001 | 34 | 9 Blocks .1001 Through .1009 (Steps of .0001) 9 Blocks .101 Through .109 (Steps of .001) 9 Blocks .110 Through .190 (Steps of .010) 4 Blocks .100, .200, .300, .500 3 Blocks 1.000, 2.000, 4.000 |
| RS 28.A1 | .020-.240 in Steps of .001 .040-.240 in Steps of .0001 .060-.240 in Steps of .00005 | 28 | 1 Block .02005 9 Blocks .0201 Through .0209 (Steps of .0001) 9 Blocks .021 Through .029 (Steps of .001) 9 Blocks .010 Through .090 (Steps of .010) |
| RS 9.A1 | .0625-4.000 in Steps of .0625 .100-4.000 in Steps of .100 | 9 | 1 Block .0625, .100, .125, .200, .250, .300, .500, 1.000, 2.000 |
| Micrometer Checking Set | | | B89.1.9 Accuracy Grade AS1* |
| Cat. No. | Measuring Range | Blocks Per Set | Blocks Included In Sets |
| RS 10.A | | 10 | 10 blocks .105, .210, .315, .420, .500, .605, .710, .815, .920, 1.000 |

For gage block accessories, order AC 11.A Accessory Set in Case. See rectangular block accessories on the next page. Sets include etched serial numbers and Commercial Calibration Certificate. A Master Calibration Certificate is available at extra cost.

* For complete accuracy specifications, see the beginning of this section.



GAGE BLOCK SETS

MICROACCURATE® B-GRADE RECTANGULAR STEEL GAGE BLOCK SETS IN CASE

These B-Grade gage block sets are Starrett Global products. Their very affordable price makes them ideal for general shop floor use.

- Etched, unique serial numbers are included on each block. Custom numbers are not available.
- Sets available with a choice of two types of certificates of calibration as described below
- Inch System sets have a tolerance of $\pm 50\mu\text{in}$.
- Metric System sets have a tolerance of $\pm 1.25\mu\text{m}$.



RS 81.B

INCH AND METRIC

| MicroAccurate® Inch System Sets | | | |
|-----------------------------------|--|----------------|---|
| Cat. No. | Measuring Range | Blocks Per Set | Blocks Included In Sets |
| RS 81.B RS 81.W | .100-12.000 in steps of .001 .200-12.000 in steps of .0001 | 81 | 9 blocks .1001 through .1009 (steps of .0001) 49 blocks .101 through .149 (steps of .001) 19 blocks .050 through .950 (steps of .050) 4 blocks 1.000 through 4.000 (steps of 1) |
| MicroAccurate® Metric System Sets | | | |
| Cat. No. | Measuring Range | Blocks Per Set | Blocks Included In Sets |
| RS 88.MB RS 88.MW | 3.0 through 450 in .0005 steps 2.0 through 450 in .001 steps 1.0 through 450 in .01 steps 1.0 through 450 in .1 steps | 88 | 1 block .5 1 block 1.0005 9 blocks 1.001 through 1.009 (steps of .001) 49 blocks 1.01 through 1.49mm (steps of .01) 18 blocks 1 through 9.5 (steps of .5) 10 blocks 10 through 100 (steps of 10) |
| RS 112.MB RS 112.MW | 3.0 through 250 in .0005 steps 2.0 through 250 in .001 steps 1.0 through 250 in .01 steps 1.0 through 250 in .1 steps | 112 | 1 block .5 1 block 1.0005 9 blocks 1.001 through 1.009 (steps of .001) 49 blocks 1.01 through 1.49 (steps of .01) 48 blocks 1 through 24.5 (steps of .5) 4 blocks 25 through 100 (steps of 25) |

| Specifications | |
|---------------------|--|
| Cat. No. | Features |
| RS 81.B RS 88.MB | Calibration performed at Webber Gage in Cleveland, OH. Certificate of Calibration with NVLAP® accreditation. Calibration in accordance with ISO 17025 with dated calibration certificate and NIST traceability number. The name and address of the user may be added to the calibration certificate. |
| RS 112.MB | Inch System (RS 81.B) uncertainty of measurement ($k=2$): $U = 6 + L$ where L is in inches, but U not less than 7 min. Metric Systems (RS 88.MB and RS 112.MB) uncertainty of measurement ($k=2$): $U = 0.15 + .001L$ where L is in millimeters, but U not less than 0.18 μm . |
| RS 81.W RS 88.MW | Calibration performed in China in partnership with Webber Gage. Webber Gage samples the measurements to monitor the calibration results. Calibrations are traceable to NIST, but no NIST traceability number or dates will be given. The name and address of the user will be left blank on the calibration certificate. |
| RS 112.MW | Inch System (RS 81.W) uncertainty of measurement ($k=2$): 10 μin . Metric Systems (RS 88.MW and RS 112.MW) uncertainty of measurement ($k=2$): $U = 0.25 \mu\text{m}$. |



GAGE BLOCK ACCESSORIES



AC11..MA

INCH



Rectangular Inch System Steel and croblox® Accessories Individually or Sets as Stated Below

Individual Accessories

| Description | Cat. No. Steel | croblox® | Steel Accessories Included Set AC 11.A |
|-------------------------------|-------------------|----------|---|
| Half-Round Jaw .250 Radius | RA 1. | | 2** |
| Straight Jaw* .250" Thick | RA 4. | RA 24. | 2** |
| Clamps | | | |
| 0" – 1-1/2" Capacity | RA 5. | | 1 |
| 1-1/2" – 4" Capacity | RA 6. | | 1 |
| 4" – 6-1/2" Capacity | RA 7. | | 1 |
| 0" – 12" Capacity | RA 8. | | 1 |
| Scriber Point | RA 11. | | 1 |
| Center Point, 100 C/L | RA 12. | | 1 |
| Base Block 1" Thick | RA 13. | | 1 |
| Case (CS 9111.) | | | 1 |

Additional Accessories

| Cat. No. | Description |
|----------|-----------------|
| | Clamps |
| RA 9. | 0-18" Capacity |
| RA 10. | 0-24" Capacity |
| RA 14. | 0-36" Capacity |
| | Half-Round Jaws |
| RA 2. | .200 Radius |
| RA 3. | .100 Radius |

* croblox jaws available as an option at extra cost. Please specify.

** Jaws are normally used in pairs, but are ordered individually. Please order accordingly.

Rectangular croblox® Wear Blocks

| Cat. No. | Size |
|-------------|-------|
| RC .020 WA1 | 0.020 |
| RC .050 WA1 | 0.050 |
| RC .100 WA1 | 0.100 |

INCH



Square croblox® – Inch System Gage Block Sets in Case

| Cat. No. | Accuracy Grade* | Measuring Range | Blocks Per Set | Blocks Included In Sets |
|----------------------|-------------------------|--|----------------|---|
| SC 81.A1 SC 81.AA | B89.1.9 0 B89.1.9 00 | .100-12.000 in Steps of .001 .200-12.000 in Steps of .0001 | 81 | 9 blocks .1001 through .1009 (Steps of .0001) 49 blocks .101 through .149 (Steps of .001) 19 blocks .050 through .950 (Steps of .050) 4 blocks 1.000 through 4.000 (Steps of 1) |
| SC 88.A1 SC 88.AA | B89.1.9 0 B89.1.9 00 | .100-12.000 in Steps of .001 .200-12.000 in Steps of .0001 .300-12.000 in Steps of .000025 1/16-12.000 in Steps of 1/64 | 88 | Same as in SC 81. Set, Plus 3 blocks .100025, .10005, .100075 4 blocks 1/16, 5/64, 3/32, 7/64 |
| SC 36.A1 SC 36.AA | B89.1.9 0 B89.1.9 00 | .200-8.000 in Steps of .001 .300-8.000 in Steps of .0001 | 36 | 1 Block .050 9 blocks .1001 through .1009 (Steps of .0001) 9 blocks .101 through .109 (Steps of .001) 9 blocks .110 through .190 (Steps of .010) 5 blocks .100 through .500 (Steps of .100) 3 blocks 1.000, 2.000, 4.000 |

All Square croblox® sets above are available with accessories at extra cost. To order, add "X" to catalog number. Accessories are furnished in steel (see following pages). Sets include etched serial numbers and Commercial Calibration Certificate. A Master Calibration Certificate is available at extra cost.

* For complete accuracy specifications, see the beginning of this section.



GAGE BLOCK SETS

INCH SYSTEM INDIVIDUAL GAGE BLOCK SETS IN CASE



SC88.A1X

INCH



| Square Steel Gage Block Sets in Case | | | B89.1.9 Accuracy Grade 0* |
|--------------------------------------|--|----------------|--|
| Cat. No. | Measuring Range | Blocks Per Set | Blocks Included In Sets |
| SS 81.A1 | .100-12.000 in steps of .001 .200-12.000 in steps of .0001 | 81 | 9 blocks .1001 through .1009 (steps of .0001) 49 blocks .101 through .149 (steps of .001) 19 blocks .050 through .950 (steps of .050) 4 blocks 1.000 through 4.000 (steps of 1") Above set also available with accessories** (extra) |
| SS 88.A1 | .100-12.000 in steps of .001 .200-12.000 in steps of .0001 .300-12.000 in steps of .000025 1/16-12.000 in steps of 1/64 | 88 | Same as in SS 81.A1 Set, Plus 3 blocks .100025, .10005, .100075 4 blocks 1/16, 5/64, 3/32, 7/64 Above set also available with accessories** (extra) |
| SS 36.A1 | .200-8.000 in steps of .001 .300-8.000 in steps of .0001 | 36 | 1 Block .050 9 blocks .1001 through .1009 (steps of .0001) 9 blocks .101 through .109 (steps of .001) 9 blocks .110 through .190 (steps of .010) 5 blocks .100 through .500 (steps of .100) 3 blocks 1.000, 2.000 and 4.000 Above set also available with accessories** (extra) |
| SS 28.A1 | .020-.240 in steps of .001 .040-.240 in steps of .0001 .060-.240 in steps of .00005 | 28 | 1 block .02005 9 blocks .0201 through .0209 (steps of .0001) 9 blocks .021 through .029 (steps of .001) 9 blocks .010 through .090 (steps of .010) |
| SS 8.A1X | 5.000-84 in steps of 1.000 | 8 | 8 blocks 5, 6, 7, 8, 10, 12, 16, 20 Accessories Included: 6 each SA 8. Studs 2 each SA 9. flat head screws (long) 2 each SA 10. flat head screws (short) 1 each SA 16. 4-1/2 - 6" tie rod (adjustable) 1 each SA 17. 6-9" tie rod (adjustable) 1 each SA 18. 11-3/4" tie rod 1 each SA 19. 15-3/4" tie rod 2 each SA 20. 19-3/4" tie rods |
| Square Steel Gage Block Sets in Case | | | B89.1.9 Accuracy Grade 00* |
| Cat. No. | Measuring Range | Blocks Per Set | Blocks Included In Sets |
| SS 8.AAX | 5.000-84 in steps of 1.000 | 8 | Same as above SS 8.A1X |

* For complete accuracy specifications, see page at the beginning of this section.

** All square steel sets 34 through 88 are available with Accessories at extra cost. To order, add "X" to catalog number. Accessories are steel. See square block Accessories on the next page. Sets include etched serial numbers and Commercial Calibration Certificate. A Master Calibration Certificate is available at extra cost.



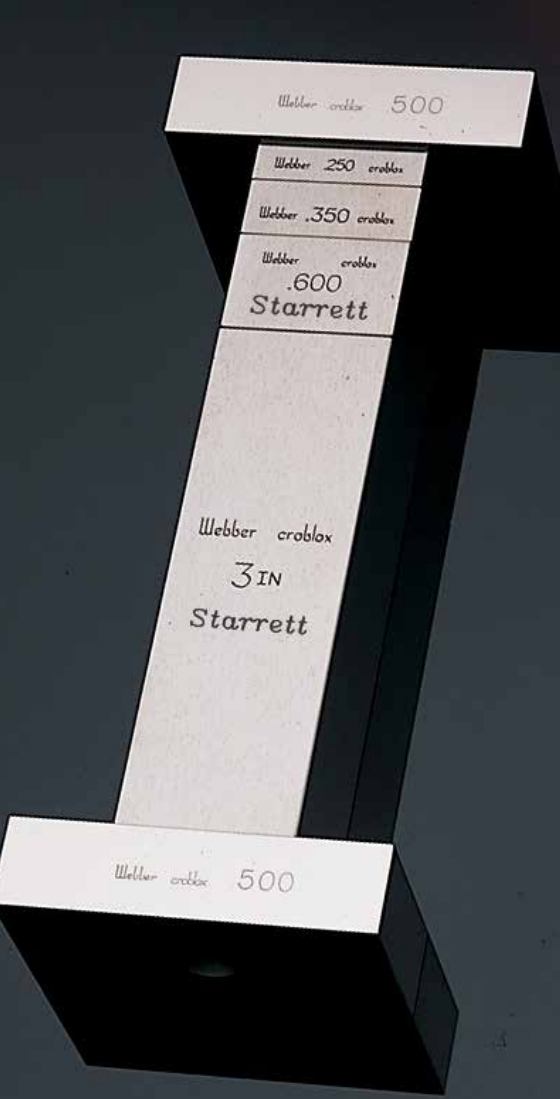

GAGE BLOCK ACCESSORIES

SA 707. STEEL INTERNAL MEASURING MACHINE JAWS

Jaws are double-ended, self-proving, assuring parallelism and squareness. Designed for use with square style gage blocks. Jaws are made of hardened steel material, 2.000" long, 1.000" wide and .500" thick. Both side edges are lapped 90° square to the gaging faces within 30 seconds of arc and extend beyond the gage blocks in the combination, thus forming a square master.

Jaw and gage combination parallelism is quickly checked merely by turning the combination to the opposite side and rechecking the reading. Furnished in pairs.

| Additional Accessories | |
|------------------------|---------------|
| Cat. No. | Description |
| | Tie Rods |
| SA 18. | 11-3/4" Solid |
| SA 19. | 15-3/4" Solid |
| SA 20. | 19-3/4" Solid |

SQUARE GAGE BLOCK ACCESSORIES STEEL AND CROBLOX[®]

INCH



Square Steel Accessories Individually or Sets as Stated Below

| Description | Cat. No. | Steel Accessories Included | |
|------------------------|----------|---|--|
| | | Set SA 25.A and 81 thru 88 Block Sets when Ordered with Accessories | 34 and 36 Block Sets when Ordered with Accessories |
| Half-Round Jaw* | | | |
| .125 Radius | SA 1. | 2 | |
| .250 Radius | SA 2. | 2 | 2 |
| Straight Jaw* | | | |
| .500" Thick | SA 3. | 2 | |
| Scriber Point | SA 4. | 1 | 1 |
| Center Point, .100 C/L | SA 5. | 1 | |
| Base Block .500 Thick | SA 6. | 1 | |
| Knurled Screw | SA 7. | 2 | 2 |
| Stud | SA 8. | 2 | 2 |
| Flat Head Screw | | | |
| Long | SA 9. | 2 | 2 |
| Short | SA 10. | 2 | 2 |
| Slotted Nut | SA 11. | 2 | 2 |
| Tie Rods | | | |
| 3/4" Solid | SA 12. | 1 | 1 |
| 1-1/2" Solid | SA 13. | 1 | 1 |
| 2-1/4" Solid | SA 14. | 1 | 1 |
| 3" Solid | SA 15. | 1 | 1 |
| 4-1/2-6" Adjust | SA 16. | 1 | 1 |
| 6-9" Adjust | SA 17. | 1 | |
| Case (CS9168) | | (For SA 25.A Only) | |

*Jaws are normally used in pairs, but are ordered individually. Please order accordingly.



GAGE BLOCKS

INDIVIDUAL RECTANGULAR GAGE BLOCKS

INCH

HOW TO ORDER

RECTANGULAR BLOCK SIZES

- Width: all blocks are .352" wide
- Length: for blocks under .050", length is 1.115"
- For blocks with .050" through .190", length is 1.180"
- For blocks .200" and above, length is 1.380"

EXCEPTIONS

- 28 block sets with blocks to .090" are all 1.115" long
- .050, .060, .070, .080, .090" blocks in this set are listed with the suffix "ss".
- .050, .100, .150" blocks contained in the 81–92-piece sets are 1.380" long. Specify "long length".
- .100" blocks contained in the 36, 38, and 43-block sets are 1.380" long. Specify "long length".

| Specify in this Sequence: Shape, Material, Size and Accuracy Grade | | | |
|--|-----------|-----------------|-----------------|
| Shape | Material | Size | Accuracy |
| R=Rectangular | S=Steel | Listed in table | Listed in table |
| S=Square | C=croblox | | |
| | Y=Ceramic | | |

Example: RS .250A1 = Rectangular Steel block, size .250, Grade A1 Accuracy

| croblox®, Ceramic and Steel Gage Blocks | croblox® | | Ceramic | | Steel |
|---|----------|----|---------|----|-------|
| | A1 | AA | A1 | AA | A1 |
| Grade | 0 | 00 | 0 | 00 | 0 |
| 0.010 | • | • | | | • |
| 0.0101 | | | | | • |
| .0101 Through .0109 in Steps of .0001 | | | | | • |
| .011 Through .019 in Steps of .001 | | | | | • |
| .020 (Wear Blocks) | • | | | | |
| .020 or .02005 | • | • | | | • |
| .0201 Through .0209 in Steps of .0001 | • | • | | | • |
| .021 Through .029 in Steps of .001 | • | • | | | • |
| 0.03 | • | • | | | • |
| 0.04 | • | • | | | • |
| .050 long* | • | • | • | • | • |
| .050 (Wear Blocks) | • | | | | |
| .050S or .050SS | • | • | | | • |
| 0.0501 | | | | | • |
| .0501 Through .0509 in Steps of .0001 | | | | | • |
| .051 Through .059 in Steps of .001 | | | | | • |
| .060 or .060SS | • | • | | | • |
| .0625 (1/16) | • | • | • | • | • |
| .070 or .070SS | • | • | | | • |
| .078125 (5/64) | • | • | • | • | • |
| .080 or .080SS | • | • | | | • |
| .090 or .090SS | • | • | | | • |
| .09375 (3/32) | • | • | • | • | • |
| .100 long* | • | • | • | • | • |
| .100 (Wear Blocks) | • | | | | |
| .100S | • | • | • | • | • |
| 0.1000 | • | • | • | • | • |
| 0.1001 | • | • | • | • | • |
| 0.1001 | • | • | • | • | • |
| .1001 Through .1009 in Steps of .0001 | • | • | • | • | • |
| .101 Through .109 in Steps of .001 | • | • | • | • | • |
| .109375 (7/64) | • | • | • | • | • |
| .110 Through .119 in Steps of .001 | • | • | • | • | • |
| .120 Through .129 in Steps of .001 | • | • | • | • | • |
| .130 Through .139 in Steps of .001 | • | • | • | • | • |
| .140 Through .149 in Steps of .001 | • | • | • | • | • |
| .150 Long* | • | • | • | • | • |
| 0.15 | • | • | • | • | • |
| .160 Through .190 in Steps of .010 | • | • | • | • | • |
| .200, .250, .300, .350 | • | • | • | • | • |
| .400, .450, .500, .550, .600 | • | • | • | • | • |
| .650, .700, .750 | • | • | • | • | • |
| .800, .850, .900, .950 | • | • | • | • | • |
| 1.000 | • | • | • | • | • |
| 2.000 | • | • | • | • | • |
| 3.000 | • | • | • | • | • |
| 4.000 | • | • | • | • | • |
| 5.000 | | | | | • |
| 6.000 | | | | | • |

* Order long length for Webber set replacements.



GAGE BLOCKS

INDIVIDUAL SQUARE GAGE BLOCKS

INCH



HOW TO ORDER

SQUARE BLOCK SIZE

- All square blocks are .950" x .950"
- Blocks have a .265" hole in the center
- On blocks .200" thick and over, the hole is countersunk on both faces (croblox® Wear Blocks are countersunk on one face only)

| croblox® and Steel Gage Blocks | croblox® | | Steel | |
|---------------------------------------|----------|----------|---------|----------|
| | A1 0 | AA 00 | A1 0 | AA 00 |
| Grade | | | | |
| 0.010 | | | • | |
| 0.020 | | | • | |
| 0.0201 | | | • | |
| .0201 Through .0209 in Steps of .0001 | | | • | |
| .021 Through .029 in Steps of .001 | | | • | |
| 0.030 | | | • | |
| 0.040 | | | • | |
| 0.050 | • | • | • | |
| 0.060 | | | • | |
| .0625 (1/16) | • | • | • | |
| 0.070 | | | • | |
| .078125 (5/64) | • | • | • | |
| 0.080 | | | • | |
| 0.090 | | | • | |
| .09375 (3/32) | • | • | • | |
| 0.100 | • | • | • | |
| .100 (Wear with Chamfered Hole) | • | | | |
| 0.1000 | • | • | • | |
| 0.1001 | • | • | • | |
| 0.1001 | • | • | • | |
| .1001 Through .1009 in Steps of .0001 | • | • | • | |
| .101 Through .149 in Steps of .001 | • | • | • | |
| .109375 (7/64) | • | • | • | |
| .150 Through .190 in Steps of .010 | • | • | • | |
| 0.200 | • | • | • | |
| 0.250 | • | • | • | |
| 0.300 | • | • | • | |
| 0.350 | • | • | • | |
| .400, .450, .500, .550 | • | • | • | |
| .600, .650, .700, .750 | • | • | • | |
| .800, .850, .900, .950 | • | • | • | |
| 1.000 | • | • | • | |
| 2.000 | • | • | • | |
| 3.000 | • | • | • | |
| 4.000 | • | • | • | |
| 5.000 | | | • | • |
| 6.000 | | | • | • |
| 7.000 | | | • | • |
| 8.000 | | | • | • |
| 10.000 | | | • | • |
| 12.000 | | | • | • |
| 16.000 | | | • | • |
| 20.000 | | | • | • |

Specify in this sequence: Shape, Material, Size and Accuracy Grade

| Shape | Material | Size | Accuracy |
|---------------|-----------|-----------------|-----------------|
| R=Rectangular | S=Steel | Listed in table | Listed in table |
| S=Square | C=croblox | | |

Example: SS .125A1 = Square Steel block, size .125 with a Grade A1 accuracy



GAGE BLOCKS

HEAVY-DUTY STEEL GAGE BLOCK SETS AND ACCESSORIES

GAGING AREA 17/32 X 1-1/2"

These heavy-duty gage block sets are primarily used for assembling together into exclusive Webber fixtures.

Precision "yardsticks" and height gages can be built up to a required dimension by wringing blocks together and then by the use of eccentric clamps, locking them into place. All blocks over 1" long have 1/4" holes that accept eccentric clamps. All blocks 6" or larger have an insulated center grip to eliminate temperature variations caused by handling.

Precision scribes and dividers for tool layout can be created in a few seconds. The center point is on a .500" center line of a 1" block. The scriber point may be sharpened indefinitely without altering the original accuracy.

Snap gages with inside or outside calipers can be easily assembled using accessories like the eccentric clamps, a quick-acting clamp, and a pair of half-round or straight jaws.



HD46.A1X

INCH 



Building up blocks into precision "yardsticks"



HD 46.A1X

Snap gage is used to check inside dimensions of ring gage still mounted in internal grinder



Precision scribes, dividers and snap gages



ACCESSORY SETS

INDICATOR ACCESSORY SET

This heavy-duty accessory mounts on any build-up of heavy-duty blocks and measures the deviation of the work from nominal or desired size. (Indicator is set and checked for zero by placing blocks on any known flat surface.)

HDA 10 and HDA 12 Indicator Accessory Sets consist of a holding block, extension jaw and a precision Starrett indicator. See catalog description below for indicator ranges and graduations.

Indicator Accessory Set



Eccentric clamps are used for combining long blocks



INCH  



Quick-acting clamps are used for combining fractional inch blocks with blocks 1" or longer

Heavy-Duty Steel Accessories Individually or Sets as stated below

| Individual Accessories | | Steel Accessories Included in all 42 thru 46 Piece Sets or 84 Piece Set when ordered with Accessories |
|-----------------------------|----------|---|
| Description | Cat. No. | |
| Half-Round Jaw* .500 Radius | HDA 1. | 2 |
| Scriber Point | HDA 2. | 1 |
| Center Point .500 C/L | HDA 3. | 1 |
| Eccentric Clamp | HDA 4. | (See set description next page for qty.) |
| Quick-Acting Clamp | HDA 5. | 1 |
| Base Block 1.500" Thick | HDA 6. | 1 |

Additional Accessories

| Individual Accessories | | |
|--|----------|--|
| Description | Cat. No. | |
| Straight Jaw* 1.000 Thick | HDA 820. | |
| Indicator Set Consisting of: Indicator Holding Block Extension Jaw (1.000" Thick) Indicator with $\pm .010$ " Range, .0005" Graduations Case | HDA 10. | |
| Indicator Set As Above Except: Indicator with $\pm .0015$ " Range, .00005" Graduations | HDA 12. | |

* Jaws are normally used in pairs, but are ordered individually. Please order accordingly.

WEAR BLOCKS

crobox® Wear Blocks in .050" and .100" sizes are available for use with heavy-duty blocks.

| crobox® Wear Blocks | |
|---------------------|-------|
| Cat. No. | Size |
| HDC .050 WA1 | .050" |
| HDC .100 WA1 | .100" |



GAGE BLOCK SETS AND ACCESSORIES

HEAVY-DUTY STEEL

INCH

| Gage Block Sets and Accessories | | | B89.1.9 Accuracy Grade 0* |
|---------------------------------|---|----------------|--|
| Cat. No. | Measuring Range | Blocks Per Set | Blocks included in Sets |
| HD 84.A1 | .100-12.000 in steps of .001 .200-12.000 in steps of .0001 .300-12.000 in steps of .00005 | 84 | 2 blocks .100 Wear croblox® 1 block .10005 9 blocks .1001 through .1009 (steps of .0001) 49 blocks .101 through .149 (steps of .001) 19 blocks .050 through .950 (steps of .050) 4 blocks 1.000 through 4.000 (steps of 1) 3 eccentric clamps Above set also available with 2 additional eccentric clamps and accessories** (extra) |
| HD 46.A1X | .200-48.000 in steps of .001 .300-48.000 in steps of .0001 | 46 | 9 blocks .1001 through .1009 (steps of .0001) 9 blocks .101 through .109 (steps of .001) 9 blocks .110 through .190 (steps of .010) 9 blocks .100 through .900 (steps of .100) 4 blocks 1.000 through 4.000 (steps of 1) 6 blocks 6.000 10 eccentric clamps and accessories** (included) |
| HD 44.A1X | .200-36.000 in steps of .001 .300-36.000 in steps of .0001 | 44 | 9 blocks .1001 through .1009 (steps of .0001) 9 blocks .101 through .109 (steps of .001) 9 blocks .110 through .190 (steps of .010) 9 blocks .100 through .900 (steps of .100) 4 blocks 1.000 through 4.000 (steps of 1) 4 blocks 6.000 8 eccentric clamps and accessories** (included) |
| HD 42.A1X | .200-24.000 in steps of .001 .300-24.000 in steps of .0001 | 42 | 9 blocks .1001 through .1009 (steps of .0001) 9 blocks .101 through .109 (steps of .001) 9 blocks .110 through .190 (steps of .010) 9 blocks .100 through .900 (steps of .100) 4 blocks 1.000 through 4.000 (steps of 1) 2 blocks 6.000 6 eccentric clamps and accessories** (included) |

Sets include etched serial numbers and Commercial Calibration Certificate. A Master Calibration Certificate is available at extra cost.
Case for HD 84.A1 has space for accessories and six 6.000" heavy-duty blocks. To order with accessories, add "X" to catalog number.
* For complete accuracy specifications, see page at the beginning of this section.
** See previous page for accessories.

| Individual Heavy-Duty Gage Blocks – Steel Only |
|--|
| Block Size |
| 0.050 |
| .100, .100025, .10005, .100075 |
| .1001 Through .1009 In Steps of .0001 |
| .101 Through .149 In Steps of .001 |
| .150 Through .190 In Steps of .010 |
| .200 Through .950 In Steps of .050 |
| 1.000 |
| 2.000 |
| 3.000 |
| 4.000 |
| 6.000 |
| 10.000 |
| 20.000 |

To order individual blocks, specify HD followed by size and accuracy grade. Example: HD .050 A1



GAGE BLOCK SETS

METRIC SYSTEM GAGE BLOCK SETS, INDIVIDUAL BLOCKS AND ACCESSORIES

The following pages include these metric system items in the order shown:

 Rectangular gage blocks and accessories

 Square gage blocks and accessories



Metric rectangular 88 piece and square 112 sets are shown

RS 9.MA1 MINI-METRIC RECTANGULAR STEEL GAGE BLOCK SET

This mini-metric set of precision gage blocks calibrates micrometers, vernier gages and similar measuring tools. The gage blocks are also useful as setting masters for comparator-type dimensional gages and are useful in teaching the basics of metric measurement.

The set has a capacity of 61mm in 1, 0.5mm or 0.25mm steps. Its nine hardened steel blocks include these sizes: 1, 2, 2.25, 2.5, 3, 5, 10, 15 and 25mm. They are finished to B89.1.9 Accuracy Grade 0 and are furnished in a lined metal case.



Metric set RS 9.MA1



GAGE BLOCK SETS

RECTANGULAR CROBLOX® GAGE BLOCK SETS IN CASE

METRIC

| Rectangular croblox Gage Block Sets in Case, One Millimeter Base | | | | |
|--|-------------------------|--|----------------|--|
| Cat. No. | Accuracy Grade* | Measuring Range | Blocks Per Set | Blocks Included In Sets |
| RC 45.MA1 RC 45.MAA | B89.1.9 0 B89.1.9 00 | 3.0 through 450 (steps of .001) 2.0 through 450 (steps of .01) 1.0 through 450 (steps of .1) | 45 | 9 blocks 1.001mm through 1.009mm (steps of .001) 9 blocks 1.01mm through 1.09mm (steps of .01) 9 blocks 1.1mm through 1.9mm (steps of .1) 9 blocks 1mm through 9mm (steps of 1) 9 blocks 10mm through 90mm (steps of 10) |
| RC 88.MA1 RC 88.MAA | B89.1.9 0 B89.1.9 00 | 3.0 through 450 (steps of .0005) 2.0 through 450 (steps of .001) 1.0 through 450 (steps of .01) 1.0 through 450 (steps of .1) | 88 | 1 block .5 1 block 1.0005 9 blocks 1.001mm through 1.009 (steps of .001) 49 blocks 1.01mm through 1.49 (steps of .01) 18 blocks 1mm through 9.5mm (steps of .5) 10 blocks 10mm through 100mm (steps of 10) |
| RC 112.MA1 RC 112.MAA | B89.1.9 0 B89.1.9 00 | 3.0 through 250 (steps of .0005) 2.0 through 250 (steps of .001) 1.0 through 250 (steps of .01) 1.0 through 250 (steps of .1) | 112 | 1 block .5 1 block 1.0005 9 blocks 1.001 through 1.009 (steps of .001) 49 blocks 1.01 through 1.49 (steps of .01) 48 blocks 1mm through 24.5mm (steps of .5) 4 blocks 25mm through 100mm (steps of 25) |

Sets include etched serial numbers and Commercial Calibration Certificate. Metric croblox® Wear Blocks and/or Master Calibration Certificate are available at extra cost. For gage block accessories, order AC 11.MA Metric Accessory Set in Case.

* For complete accuracy specifications, see page at the beginning of this section.



Set RY 88.MA1

RECTANGULAR CERAMIC

METRIC

Now there's another addition to the famous Starrett-Webber line of precision gage blocks. Ceramic, offered in rectangular, inch and metric, fills the gap between steel and the universally accepted croblox®. While not as stable as croblox®, ceramic is an excellent alternative to steel because of its superior hardness, thermal expansion and wear characteristics.

| Gage Block Sets in Case | | | | |
|-------------------------|-------------------------|--|----------------|--|
| Cat. No. | Accuracy Grade* | Measuring Range | Blocks Per Set | Blocks Included In Sets |
| RY 45.MA1 RY 45.MAA | B89.1.9 0 B89.1.9 00 | 3.0 through 450 in .001 steps 2.0 through 450 in .01 steps 1.0 through 450 in .1 steps | 45 | 9 blocks 1.001 through 1.009 (steps of .001) 9 blocks 1.01 through 1.09 (steps of .01) 9 blocks 1.1 through 1.9 (steps of .1) 9 blocks 1 through 9 (steps of 1) 9 blocks 10 through 90 (steps of 10) |
| RY 88.MA1 RY 88.MAA | B89.1.9 0 B89.1.9 00 | 3.0 through 450 in .0005 steps 2.0 through 450 in .001 steps 1.0 through 450 in .01 steps 1.0 through 450 in .1 steps | 88 | 1 block .5 1 block 1.0005 9 blocks 1.001 through 1.009 (steps of .001) 49 blocks 1.01 through 1.49 (steps of .01) 18 blocks 1 through 9.5 (steps of .5) 10 blocks 10 through 100 (steps of 10) |

Sets include etched serial numbers and Commercial Calibration Certificate. A Master Calibration Certificate is available at extra cost.

* For complete accuracy specifications, see page at the beginning of this section.



GAGE BLOCK SETS

RECTANGULAR STEEL – METRIC SYSTEM

METRIC

One Millimeter Base

| Gage Block Sets in Case | | | B89.1.9 Accuracy Grade 0* |
|-------------------------|--|----------------|--|
| Cat. No. | Measuring Range | Blocks Per Set | Blocks Included In Sets |
| RS 9.MA1 | 1.0 through 61.0 in 1.0 steps 2.0 through 61.0 in .5 steps 4.0 through 61.0 in .25 steps | 9 | 3 blocks 1.0, 2.0, 2.25 4 blocks 2.5, 3.0, 5.0, 10.0 2 blocks 15.0, 25.0 |
| RS 45.MA1 | 3.0 through 450 in .001 steps 2.0 through 450 in .01 steps 1.0 through 450 in .1 steps | 45 | 9 blocks 1.001 through 1.009 (steps of .001) 9 blocks 1.01 through 1.09 (steps of .01) 9 blocks 1.1 through 1.9 (steps of .1) 9 blocks 1 through 9 (steps of 1) 9 blocks 10 through 90 (steps of 10) |
| RS 88.MA1 | 3.0 through 450 in .0005 steps 2.0 through 450 in .001 steps 1.0 through 450 in .01 steps 1.0 through 450 in .1 steps | 88 | 1 block .5 1 block 1.0005 9 blocks 1.001 through 1.009 (steps of .001) 49 blocks 1.01 through 1.49 (steps of .01) 18 blocks 1 through 9.5 (steps of .5) 10 blocks 10 through 100 (steps of 10) |
| RS 112.MA1 | 3.0 through 250 in .0005 steps 2.0 through 250 in .001 steps 1.0 through 250 in .01 steps 1.0 through 250 in .1 steps | 112 | 1 block .5 1 block 1.0005 9 blocks 1.001 through 1.009 (steps of .001) 49 blocks 1.01 through 1.49 (steps of .01) 48 blocks 1 through 24.5 (steps of .5) 4 blocks 25 through 100 (steps of 25) |
| Micrometer Checking Set | | | B89.1.9 Accuracy Grade AS1* |
| Cat. No. | Measuring Range | Blocks Per Set | Blocks Included In Sets |
| RS 10.MA | | 10 | 10 blocks 2.5, 5.1, 7.7, 10.3, 12.9, 15.0, 17.6, 20.2, 22.8, 25.0 |

Sets include etched serial numbers and Commercial Calibration Certificate. Metric croblox® Wear Blocks and/or Master Calibration Certificate are available at extra cost.

For gage block accessories, order AC 11.MA Metric Accessory Set in Case.

See rectangular metric block accessories on the next page.

* For complete accuracy specifications, see page at the beginning of this section.



AC11.MA

RECTANGULAR GAGE BLOCK ACCESSORIES STEEL AND CROBLOX®

Rectangular Steel and croblox Accessories Individually or Sets as Stated Below

| Individual Accessories | | | |
|------------------------------|----------|----------|---|
| Description | Cat. No. | | Steel Accessories Included Set AC 11.MA |
| | Steel | croblox® | |
| Half-Round Jaw 5mm Radius | RA 101. | | 2** |
| Straight Jaw* 5mm Thick | RA 104. | RA 204. | 2** |
| Clamps | | | |
| 0-38mm Capacity | RA 5. | | 1 |
| 38-100mm Capacity | RA 6. | | 1 |
| 100-165mm Capacity | RA 7. | | 1 |
| 0-300mm Capacity | RA 8. | | 1 |
| Scriber Point | RA 11. | | 1 |
| Center Point, 2mm C/L | RA 112. | | 1 |
| Base Block, 25mm Thick | RA 113. | | 1 |
| Case (CS 9111.) | | | 1 |

Additional Accessories

| Individual Accessories | | | |
|------------------------|----------|----------|---|
| Description | Cat. No. | | Steel Accessories Included Set AC 11.MA |
| | Steel | croblox® | |
| Clamps | | | |
| 0-450mm Capacity | RA 9. | | |
| 0-600mm Capacity | RA 10. | | |
| 0-900mm Capacity | RA 14. | | |

* croblox jaws available as an option at extra cost. Please specify.

** Jaws are normally used in pairs, but are ordered individually. Please order accordingly.

Rectangular croblox Wear Blocks

| Cat. No. | Size |
|-------------|------|
| RCM 1.0 WA1 | 1.0 |
| RCM 2.0 WA1 | 2.0 |



GAGE BLOCK SETS

SQUARE COMBINATION CROBLOX® AND STEEL METRIC SYSTEM GAGE BLOCK SETS IN CASE

METRIC



An ideal combination of value, price and convenience, these sets include a popular selection of croblox® and steel as listed.

| Gage Block Sets in Case, Two Millimeter Base | | | B89.1.9 Accuracy Grade 0* |
|--|--|----------------|--|
| Cat. No. | Measuring Range | Blocks Per Set | Blocks** Included in Sets |
| S2CS 45.MA1 | 6.0 through 450 in .001 steps 4.0 through 450 in .01 steps 2.0 through 450 in .1 steps | 45 | 1 block 1.0 - steel 9 blocks 2.001 through 2.009 (steps of .001) 9 blocks 2.01 through 2.09 (steps of .01) 9 blocks 2.1 through 2.9 (steps of .1mm) 9 blocks 1.0 through 9.0 (steps of 1.0mm) 8 blocks 10 through 90 (steps of 10mm) - steel |
| S2CS 88.MA1 | 6.0 through 450 in .0005 steps 4.0 through 450 in .001 steps 2.0 through 450 in .01 steps 2.0 through 450 in .1 steps | 88 | 2 blocks .5 and 1.0 - steel 1 block 2.0005 9 blocks 2.001 through 2.009 (steps of .001) 49 blocks 2.01 through 2.49 (steps of .01) 18 blocks 1.5 through 10.0 (steps of .5) 9 blocks 20 through 100 (steps of 10) - steel |
| S2CS 112.MA1 | 6.0 through 250 in .0005 steps 4.0 through 250 in .001 steps 2.0 through 250 in .01 steps 2.0 through 250 in .1 steps | 112 | 2 blocks .5 and 1.0 - steel 1 block 2.0005 9 blocks 2.001 through 2.009 (steps of .001) 49 blocks 2.01 through 2.49 (steps of .01) 18 blocks 1.5 through 10.0 (steps of .5) 29 blocks 10.5 through 24.5 (steps of .5) - steel 4 blocks 25m through 100 (steps of 25) - steel |
| S2C 77.MA1 | 6.0 through 300 in .0005 steps 4.0 through 300 in .001 steps 2.0 through 300 in .01 steps 2.0 through 300 in .1 steps | 77 | 5 blocks .5, 1.0, 1.5, 2.0, 2.0005 9 blocks 2.001 through 2.009 (steps of .001) 50 blocks 2.01 through 2.50 (steps of .01) 5 blocks 3.0, 3.5, 4.0, 4.5, 5.0 5 blocks 10, 15, 20, 25, 30 3 blocks 50, 75, 100 |
| Gage Block Sets in Case, Two Millimeter Base | | | B89.1.9 Accuracy Grade 00* |
| Cat. No. | Measuring Range | Blocks Per Set | Blocks** Included in Sets |
| S2C 77.MAA | 6.0 through 300 in .0005 steps 4.0 through 300 in .001 steps 2.0 through 300 in .01 steps 2.0 through 300 in .1 steps | 77 | Same as above S2C 77.MA1 |

Metric croblox® Wear Blocks are available as option. Sets include etched serial numbers and Commercial Calibration Certificate. A Master Calibration Certificate is available at extra cost.

* For complete accuracy specifications, see page at the beginning of this section.

** All blocks are croblox, except as noted.

STEEL SA 711. INTERNAL MEASURING MACHINE JAWS

Double ended, self proving - assures parallelism and squareness. Designed for use with square style gage blocks, jaws are made of hardened steel 50.8mm long, 25.4mm wide and 12mm thick. Both side edges are lapped 90° square to the gaging faces within 30 seconds of arc and extend beyond the gage blocks in the combination, thus forming a square master.

Jaw and gage combination parallelism is checked merely by turning the combination to the opposite side and rechecking the reading. Furnished in pairs.

SA712 and SA711



GAGE BLOCK SETS

SQUARE STEEL – METRIC SYSTEM GAGE BLOCK SETS IN CASE

METRIC



| Gage Block Sets in Case, Two Millimeter Base | | | B89.1.9 Accuracy Grade 0* |
|--|--|----------------|---|
| Cat. No. | Measuring Range | Blocks Per Set | Blocks Included in Sets |
| S2S 45.MA1 | 6.0 Through 450 in .001 Steps 4.0 Through 450 in .01 Steps 2.0 Through 450 in .1 Steps | 45 | 1 Block 1.0 9 Blocks 2.001 Through 2.009 (Steps of .001) 9 Blocks 2.01 Through 2.09 (Steps of .01) 9 Blocks 2.1 Through 2.9 (Steps of .1) 9 Blocks 2.0 Through 10.0 (Steps of 1.0) 8 Blocks 20 Through 90 (Steps of 10) |
| S2S 77.MA1 | 6.0 Through 300 in .0005 Steps 4.0 Through 300 in .001 Steps 2.0 Through 300 in .01 Steps 2.0 Through 300 in .1 Steps | 77 | 5 Blocks .5, 1.0, 1.5, 2.0, 2.0005 9 Blocks 2.001 Through 2.009 (Steps of .001) 50 Blocks 2.01 Through 2.50 (Steps of .01) 5 Blocks 3.0, 3.5, 4.0, 4.5, 5.0 5 Blocks 10, 15, 20, 25, 30 3 Blocks 50, 75, 100 |
| S2S 88.MA1 | 6.0 Through 450 in .0005 Steps 4.0 Through 450 in .001 Steps 2.0 Through 450 in .01 Steps 2.0 Through 450 in .1 Steps | 88 | 2 Blocks .5, 1.0 1 Block 2.0005 9 Blocks 2.001 Through 2.009 (Steps of .001) 49 Blocks 2.01 Through 2.49 (Steps of .01) 18 Blocks 1.5 Through 10.0 (Steps of .5) 9 Blocks 20 Through 100 (Steps of 10) |
| S2S 112.MA1 | 6.0 Through 250 in .0005 Steps 4.0 Through 250 in .001 Steps 2.0 Through 250 in .01 Steps 2.0 Through 250 in .1 Steps | 112 | 1 Block .5 1 Block 2.0005 9 Blocks 2.001 Through 2.009 (Steps of .001) 49 Blocks 2.01 Through 2.49 (Steps of .01) 48 Blocks 1.0 Through 24.5 (Steps of .5) 4 Blocks 25 Through 100 (Steps of 25) |
| SS 8.MA1X | 125 to 2100 | 8 | 8 Blocks 125, 150, 175, 200, 250, 300, 400, 500 Accessories Included: 6 Each SA 8. Studs 2 Each SA 9. Flat Head Screws (long) 2 Each SA 10. Flat Head Screws (short) 1 Each SA 16. 114-152 Tie Rod (adjustable) 1 Each SA 17. 152-228 Tie Rod (adjustable) 1 Each SA 18. 298 Tie Rod 1 Each SA 19. 400 Tie Rod 2 Each SA 20. 502 Tie Rods |
| Cat. No. | Measuring Range | Blocks Per Set | B89.1.9 Accuracy Grade 00* |
| SS 8.MAAX | 125 to 2100 | 8 | Blocks Included in Sets Same as Above SS 8.MA1X |

Sets include etched serial numbers and Commercial Calibration Certificate. A Master Calibration Certificate is available at extra cost.
* For complete accuracy specifications, see page at the beginning of this section.



GAGE BLOCK SETS

SQUARE STEEL OR CROBLOX[®] – METRIC SYSTEM GAGE BLOCK ACCESSORIES

METRIC



Square Steel Accessories Individually or Sets as Stated Below

| Individual Accessories | Cat. No. | Steel Accessories Included |
|------------------------|----------|----------------------------|
| Half-Round Jaw** | | |
| 3mm Radius | SA 101. | 2 |
| 6mm Radius | SA 102. | 2 |
| Straight Jaw** | | |
| 12mm Thick | SA 103. | 2 |
| Scriber Point | SA 4. | 1 |
| Center Point 2mm C/L | SA 105. | 1 |
| Base Block 12mm Thick | SA 106. | 1 |
| Knurled Screw | SA 7. | 2 |
| Stud | SA 8. | 2 |
| Flat Head Screw | | |
| Long | SA 9. | 2 |
| Short | SA 10. | 2 |
| Slotted Nut | SA 11. | 2 |
| Tie Rods | | |
| 19mm Solid | SA 12. | 1 |
| 38mm Solid | SA 13. | 1 |
| 57mm Solid | SA 14. | 1 |
| 76mm Solid | SA 15. | 1 |
| 114-152mm Adjustable | SA 16. | 1 |
| 152-228mm Adjustable | SA 17. | 1 |
| Case (CS 9168.) | | 1 |

Additional Accessories

| Individual Accessories | Cat. No. |
|------------------------|----------|
| Tie Rods | |
| 298mm | SA 18. |
| 400mm | SA 19. |
| 502mm | SA 20. |

** croblox[®] jaws available as an option at extra cost. Please specify.

** Jaws are normally used in pairs, but are ordered individually. Please order accordingly.

Square croblox[®] Wear Blocks

| Cat. No. | Size |
|-------------|-------------------------------|
| SCM 2.0 WA1 | 2.0mm with 1 Side Countersunk |

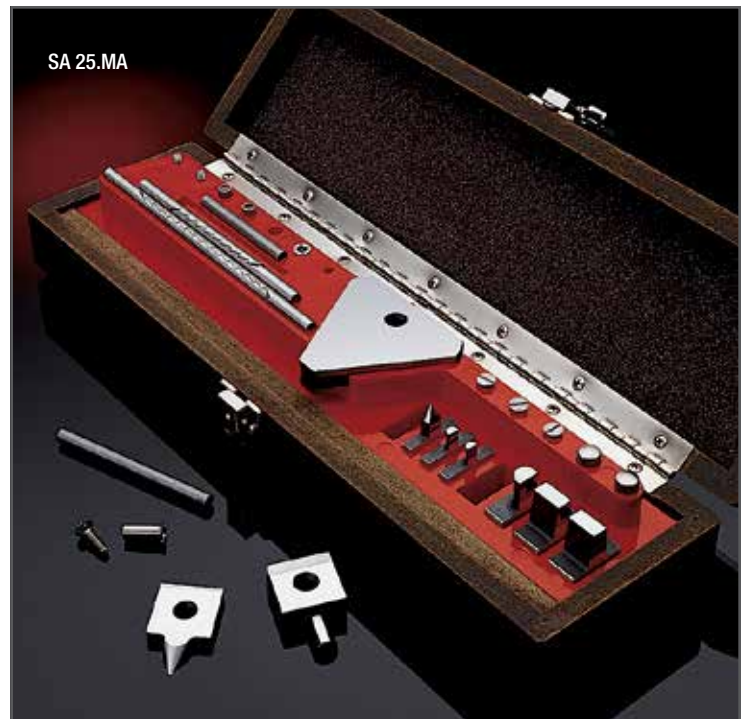

GAGE BLOCK SETS

INDIVIDUAL RECTANGULAR AND SQUARE GAGE BLOCKS - METRIC SYSTEM

croblox®, CERAMIC AND STEEL

RECTANGULAR BLOCK SIZES

- Width: all blocks are 9mm wide
- Length: For blocks 10mm thick and under, length is 30mm
For blocks 10.5mm thick and above, length is 35mm

Exceptions:

*Blocks are 28.3mm long

** When ordering 0.5mm block, specify length (28.3 or 30mm)

| Individual Rectangular Gage Blocks | | croblox® | | Ceramic | | Steel |
|--------------------------------------|-------|----------|----------|---------|----------|---------|
| Size/Millimeters | Grade | A1 0 | AA 00 | A1 0 | AA 00 | A1 0 |
| 0.3, 0.4* | | | | | | • |
| 0.5** | | • | • | • | • | • |
| 0.6 Through 0.9 in .1 Steps* | | | | | | • |
| 1.0 or 1.0005 | | • | • | • | • | • |
| 1.0 Wear Blocks | | • | | | | |
| 1.001 Through 1.009 in Steps of .001 | | • | • | • | • | • |
| 1.01 Through 1.14 in Steps of .01 | | • | • | • | • | • |
| 1.15 Through 1.49 in Steps of .01 | | • | • | • | • | • |
| 1.5 Through 1.9 in Steps of .1 | | • | • | • | • | • |
| 2.0 | | • | • | • | • | • |
| 2.0 Wear Blocks | | • | | | | |
| 2.25 | | | | | | • |
| 2.5 | | • | • | • | • | • |
| 3.0 Through 4.5 in Steps of .5 | | • | • | • | • | • |
| 5.0 Through 6.5 in Steps of .5 | | • | • | • | • | • |
| 7.0 Through 10.0 in Steps of .5 | | • | • | • | • | • |
| 10.5 Through 14.5 in Steps of .5 | | • | • | | | • |
| 15.0 | | • | • | • | • | • |
| 15.5 Through 19.5 in Steps of .5 | | • | • | | | • |
| 20.0 | | • | • | • | • | • |
| 20.5 Through 24.5 in Steps of .5 | | • | • | | | • |
| 25.0 and 30.0 | | • | • | • | • | • |
| 40.0 | | • | • | • | • | • |
| 50.0 | | • | • | • | • | • |
| 60.0 | | • | • | • | • | • |
| 70.0 | | • | • | • | • | • |
| 75.0 and 80.0 | | • | • | • | • | • |
| 90.0 | | • | • | • | • | • |
| 100.0 | | • | • | • | • | • |

SQUARE BLOCK SIZES

- All blocks are 24.1mm x 24.1mm
- Blocks have a 6.7mm hole in the center
- On blocks 5.0mm thick and over, the hole is countersunk on both faces. (croblox Wear Blocks are countersunk on one face only)

| Individual Square Gage Blocks | | croblox® | | Steel | Steel Only | |
|---|-------|----------|----------|---------|------------|----------|
| Size/Millimeters | Grade | A1 0 | AA 00 | A1 0 | A1 0 | AA 00 |
| 0.5 mm | | • | • | • | | |
| 1.0 | | • | • | • | | |
| 1.5 | | • | • | • | | |
| 2.0 Wear Blocks with 1 Side Countersunk | | • | | | | |
| 2.0 or 2.0005 | | • | • | • | | |
| 2.001 Through 2.009 in .001 Steps | | • | • | • | | |
| 2.01 Through 2.49 in .01 Steps | | • | • | • | | |
| 2.5 Through 2.9 in .1 Steps | | • | • | • | | |
| 3.0 Through 10.0 in .5 Steps | | • | • | • | | |
| 10.5 Through 14.5 in .5 Steps | | | | | • | |
| 15mm | | • | • | • | | |
| 15.5 Through 19.5 in .5 Steps | | | | | • | |
| 20.0mm | | • | • | • | | |
| 20.5 Through 24.5 in .5 Steps | | | | | • | |
| 25.0 | | • | • | • | | |
| 30.0 | | • | • | • | | |
| 40.0 | | | | | • | |
| 50.0 | | • | • | • | | |
| 60.0 | | | | | • | |
| 70.0 | | | | | • | |
| 75.0 | | • | • | • | | |
| 80.0 | | | | | • | |
| 90.0 | | | | | • | |
| 100.0 | | • | • | • | | |
| 125.0 | | | | | • | • |
| 150.0 | | | | | • | • |
| 175.0 | | | | | • | • |
| 200.0 | | | | | • | • |
| 250.0 | | | | | • | • |
| 300.0 | | | | | • | • |
| 400.0 | | | | | • | • |
| 500.0 | | | | | • | • |

HOW TO ORDER

Specify in this sequence: Shape, Material, "M" for Metric, Size and Accuracy Grade

| Shape | Material | Size | Accuracy |
|---------------|-------------|-----------------|-----------------|
| R=Rectangular | S=Steel | Listed in table | Listed in table |
| S=Square | C=croblox® | | |
| | Y = Ceramic | | |

Example: RSM 2.0.A1 = Rectangular Steel block, Metric size 2.0, Grade A1 Accuracy



REFERENCE BARS

STANDARD REFERENCE BARS

12", 19", 25", 37", 49"/300, 500, 650, 950, 1250MM

These Standard Reference Bars are invaluable for use in checking table movement of machine tools, accuracy of vernier height gages, surface plate transfer measurement, and for final inspection of precision machine tools and coordinate measuring machines.

The "channel design" places additional measuring pads at appropriate points over the length of the bar as reference points for x, y or z axis measurements. Channel design permits use of the bar on its base (vertical), or on its back, or either side (horizontal). The alternating gage block jaws and spacer blocks are permanently wrung and fastened together to form 1" increments for inch bars and 25mm increments for metric bars.

A special bushing arrangement allows the master stack to conform to thermal conditions prevailing during use, thus providing a true master even under less than perfect laboratory conditions. Mating surfaces are treated during assembly to prevent corrosion.

Non-standard lengths and measuring increments are available on special order. A Certificate of Calibration is included. All models are furnished with storage case.

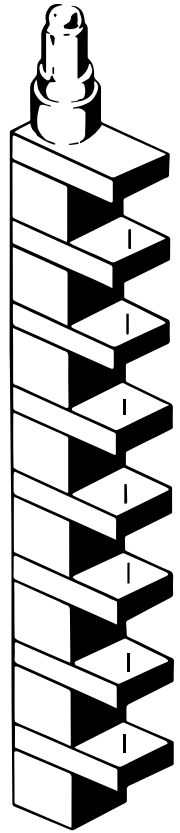

With Channel Design

| Inch System | | | Millimeter System | | |
|-------------|-------|------|-------------------|-------|--------|
| Cat. No. | EDP | Size | Cat. No. | EDP | Size |
| RBC 12. | 92626 | 12" | RBCM 300. | 93642 | 300mm |
| RBC 19. | 92627 | 19" | RBCM 500. | 92617 | 500mm |
| RBC 25. | 92628 | 25" | RBCM 650. | 93053 | 650mm |
| RBC 37. | 92629 | 37" | RBCM 950. | 92619 | 950mm |
| RBC 49. | 92630 | 49" | RBCM 1250. | 92620 | 1250mm |

Free Standing Stack Without Channel Design – Vertical Position Only

| Inch System | | | Millimeter System | | |
|-------------|-------|------|-------------------|-------|-------|
| Cat. No. | EDP | Size | Cat. No. | EDP | Size |
| RB 8. | 92616 | 8" | RBM 200. | 93261 | 200mm |
| RB 10. | 92623 | 10" | RBM 250. | 93262 | 250mm |
| RB 12. | 92624 | 12" | RBM 300. | 93263 | 300mm |
| RB 18. | 92625 | 18" | RBM 450. | 93264 | 450mm |

Specifications

| Description | Inch System | Millimeter System |
|---|---|---|
| Tolerance (Stack) | expressed in μin . | expressed in μm |
| Maximum: | 2.5L + 10L in inches | .0025L + .25L in millimeters |
| Minimum: | - 10 | -.25 |
| Parallelism: Gage Surfaces to Base and Each Other | 15 μin . | 0.4 μm |
| Uncertainty of Calibration | 10 + 2.0L in inches expressed in μin . | .25 + .002L in millimeters expressed in μm . |

The accuracy of the surface that supports the gage must be taken into account when determining the accuracy of any measurements.

Standard Sizes are 12", 19", 25", 37" and 49" in the inch system and 300mm, 500mm, 650mm, 950mm and 1250mm in the millimeter system





AG 18.W



AG 16.R

GAGE BLOCK SETS

ANGLE GAGE BLOCK SETS

Angle Gage Blocks permit fast, simple and accurate measurements of any angle. They are far superior to sine bar measuring methods, that involve trigonometric formulae and complex stacks of gage blocks.

Angle gage blocks come in three accuracies: croblox® Reference Angle Blocks with a 1-second accuracy, steel Calibration Grade Angle Blocks with 2-second accuracy, and steel Working Grade Angle Blocks with 5-second accuracy. Each grade can be purchased in sets that will measure in steps of one-second, one-minute or one-degree to suit any need. (See angle block specification information on next two pages.)

- **Reference Angle Blocks croblox: 1-second accuracy.** Designed for optical or as reference standards for autocollimators, spectrometers, etc. They are unsurpassed for use in aerospace, optical, and precision instrument fields.
- **Calibration Angle Blocks Steel: 2-second accuracy.** The same high quality as the Reference Grade Angle Blocks.
- **Working Angle Blocks Steel: 5-second accuracy.** These angles are designed for shop or tool room. The longer gaging surfaces are made for use with an indicator. These blocks reduce set-up time and minimize error in grinding both simple and compound angles.

| Angle Gage Block Sets in Case | | | | |
|-------------------------------|---|----------------|-------------------|---|
| Cat. No. | Description/Accuracy Grade | Blocks Per Set | Measuring Range | Blocks Included in Sets |
| AG 6.R AG 6.C | Reference Grade ±1.0 Second Calibration Grade ±2.0 Seconds | 6 | 0-99° in 1° Steps | 6 Blocks: 1°, 3°, 5°, 15°, 30°, 45° |
| AG 11.R AG 11.C | Reference Grade ±1.0 Second Calibration Grade ±2.0 Seconds | 11 | 0-99° in 1' Steps | 6 Blocks: 1°, 3°, 5°, 15°, 30°, 45° 5 Blocks: 1', 3', 5', 20', 30' |
| AG 16.R AG 16.C | Reference Grade ±1.0 Second Calibration Grade ±2.0 Seconds | 16 | 0-99° in 1" Steps | 6 Blocks: 1°, 3°, 5°, 15°, 30°, 45° 5 Blocks: 1', 3', 5', 20', 30' 5 Blocks: 1", 3", 5", 20", 30" |

| Cases for Angle Gage Block Sets | |
|---------------------------------|------------------------------------|
| Cat. No. | Description |
| CS 9135 | Calibration Set and Reference Case |

* One 6" (150mm) parallel and one 6" (150mm) knife edge are included with Working Grade Sets in addition to the listed sizes.

| To Order Individually, Specify in the Following Key Sequence: | | | |
|---|-----------------------|----------------------------------|-----------------------|
| Angle Gage Prefix | Numeric Size of Angle | Angle Units (Degree, Min., Sec.) | Accuracy Grade R or C |
| AG | 45 | D | R |

Example: AG 45.DR = a Reference 45° Angle Block
AG 30. MC = Calibration Grade 30' Angle Block

NOTE: The catalog numbers and specifications of our angle gage blocks have been changed in response to updated requirements concerning the application of the uncertainty of measurement. See the next two pages for information regarding the specifications of our angle blocks.



WEBBER GAGE BLOCKS

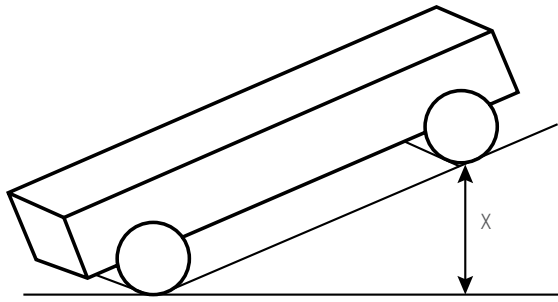

USING ANGLE GAGE BLOCKS

SUPERIOR TO SINE BAR METHODS

A precision angle has always been difficult to set because of the involved trigonometric formula that is used with the sine bar.

The main difficulty lies in the dimension X in diagram, which often results in a figure with many decimal places. Gage blocks can only approximate this value. For example, to measure 44° 30' using a 5" sine bar the following steps are required:

| | |
|---|-----------|
| Sine for 44° 30' angle | .7009093 |
| For dimension X multiply by 5 | 3.5045465 |
| | .1005 |
| | .104 |
| Gage Blocks necessary to match this dimension | .300 |
| | 3.000 |
| | 3.5045 |

3.5045465 – 3.5045 = Residual error .0000465
This error cannot be eliminated in sine bar procedure.

With angle gage blocks, you take a 45° block from the set, wring on a 30° block so that the plus end of 45° block contacts the minus end of 30° block, and you have an angle of 44° 30'. It is not only easy to accomplish, it is absolutely accurate.

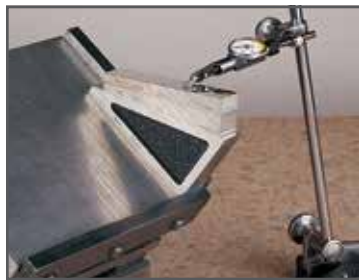

SETTING A REVOLVING MAGNETIC CHUCK

A chuck is set for a 38° angle. Three blocks, +30°, +5° and +3°, are assembled and mounted with the parallel*. The indicator quickly tells if the setting is accurate. Adjustment is a matter of seconds. A revolving chuck teams up perfectly with angle blocks to make possible several applications in tool grinding that are more difficult with other methods.

EASE AND VERSATILITY

A set consisting of only 16 blocks will measure 356,400 angles in steps of one second, to an accuracy of 1/5,000,000th of a circle! These micro-accurate blocks can be used in either plus or minus positions. In example "A", take the 30° angle and add the 5° angle to obtain a measurement of 35° (making sure that both plus ends are together). In "B", use the same two blocks but wring them together so that the minus end of the 5° block is over the plus end of the 30° block. This will subtract 5° from 30°, thus giving a 25° measurement.

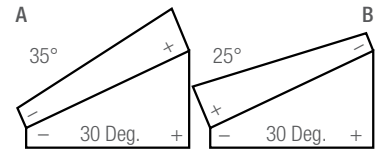

INDEXING A LARGE ROTARY TABLE

A Webber Angle Block or True Square is positioned on the work and a beam of light from an autocollimator is directed against the gaging surface. This becomes 0°, or the reference surface. Other angle blocks are then added in proper combination to measure each succeeding angle. The table is rotated and inspected at each position with reference to the light beam. This method indexes large workplaces quickly, with accuracy measured in fractional seconds.

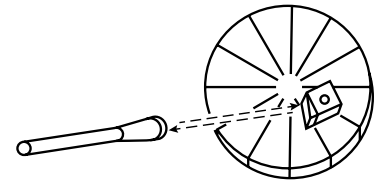

INSPECTING A SIMPLE ANGLE

The photo above shows a workpiece on which an angle of 30° is required. The workpiece is resting on a parallel* which is wrung to angle blocks forming 30°. The entire set-up is lined up vertically with an angle plate and then indicated across the top of the work to determine the correctness of the angle.



*Parallels are not necessary, but they are convenient because of their longer reference surface.

| Angle Gage Block Specifications | Accuracy In Microinches (Microns) | |
|--|-----------------------------------|--------------------------------|
| Material | Reference Grade croblox® | Calibration Grade Steel |
| Tolerances: Deviation From Nominal | ±1.0 second | ±2.0 second |
| Flatness of Gaging Surfaces | 6µin. (0.15µm) | 8µin. (0.20µm) |
| Flatness and Parallelism of Sides | 8µin. (0.20µm) | 8µin. (0.20µm) |
| Squareness of Sides to Gaging Surfaces | 6 seconds | 8 seconds |
| Area of Gaging Surfaces† | 1 x 2" (25 x 50mm) | 1 x 2" (25 x 50mm) |
| Surface Finish (Gage Surfaces Only) | 0.4µin. AA (.01µm AA) | 0.6µin. AA (.015µm AA) |
| Estimated Uncertainty of Measurement (k=2) | 0.6 seconds | 1.0 seconds |

Flatness tolerances exclude 1.5mm from the edges on all angle blocks, except where marked with **. Then 3mm from the edge is excluded.
† Dimension of gaging surfaces in millimeters is approximate.



WEBBER GAGE BLOCKS

TRUE SQUARES

True squares are designed for fast, precision indexing with angle gage blocks.

All faces of Webber True Squares are at precisely 90° to adjacent sides, with perfect optical flatness and parallelism to permit use with autocollimators.

Applications for fast precision indexing and setting of angular grinding fixtures are almost unlimited. For example: the work and the true square are mounted together on a revolving fixture. A notch is ground by two successive cuts, one at 90° with the true square, and the other at 2° with the addition of two angle blocks (+3° and -1°) mounted on square. An indicator reading is taken before each grind. This process is then repeated by turning the True Square to successive zero readings.

True Squares are designed for use as an accessory to our angle gage blocks to easily make angles greater than 45° and through 180°.

Webber True Squares also permit a fast, easy check of indexing tables. The gaging faces are at precise 90° angles with optical flatness and finishes that permit the use of autocollimators.

The catalog numbers and specifications of our True Squares have been changed in response to updated requirements concerning the application of the uncertainty of measurement.

| True Square Specifications | | | | |
|--|------------------------|------------------------|------------------------|------------------------|
| Cat. No. | TS 21.R | TS 21.C | TS 44.W | TS 66.W |
| Grade | Reference | Calibration | Working | Working |
| Material | croblox® | Steel | Steel | Steel |
| Tolerances: Deviation From Nominal | ±1.0 second | ±2.0 second | ±5.0 second | ±5.0 second |
| Flatness of Gaging Surfaces | 6µin. (0.15µm) | 8µin. (0.20µm) | 14µin. (0.35µm)* | 14µin. (0.35µm)* |
| Flatness & Parallelism of Sides | 8µin. (0.20µm) | 8µin. (0.20µm) | 16µin. (0.40µm)* | 16µin. (0.40µm)* |
| Squareness of Sides to Gaging Surfaces | 6 seconds | 8 seconds | 12 seconds | 12 seconds |
| Area of Gaging Surfaces† | 1" x 2" (25 x 50mm) | 1" x 2" (25 x 50mm) | 5/8" x 4" (16 x 100mm) | 5/8" x 6" (16 x 150mm) |
| Surface Finish (Gage Surfaces Only) | 0.4µin. AA (0.01µm AA) | 0.6µin. AA (.015µm AA) | 1.0µin. AA (.025µm AA) | 1.0µin. AA (.025µm AA) |
| Estimated Uncertainty of Measurement (K=2) | 0.6 seconds | 1.0 seconds | 3.5 seconds | 4.0 seconds |

Flatness tolerances exclude 1.5mm from the edges on all angle blocks except where marked with *. Then, 3mm from the edge is excluded.
 † Dimension of gaging surfaces in millimeters is approximate.



True Square



CROBLOX[®]

CROBLOX REFLECTING CUBES

Stable and maintenance free, reflecting cubes are ideal for 90° indexing or alignment in optical tooling or inspection.

croblox[®] Reflecting Cube



TO ORDER, SPECIFY THE FOLLOWING INFORMATION:

- The number and position of all finished sides, including the base:
 - NOTE:** for fixturing purposes during manufacturing, the bottom face must be one of the finished sides. The bottom face is etched with the Webber logo, a serial number, and face identifications as applicable.
- Specify the manufacturing tolerances of the 90° angles, 1 second, 3 seconds, or other angular specification.
- A certificate of calibration showing the deviation from 90° of the finished sides is available at extra cost.
 - NOTE:** Our uncertainty of measurement is estimated to be ±1.0 seconds. This uncertainty should be added to the manufacturing tolerance to give practical tolerance of the cube.
- If requested, a copy of the material certificate from our supplier of chrome-carbide is available at no extra cost.

| To Order Webber Optical Cubes | | | | | |
|--|------|------------------------------|---|---|----------|
| Specify all 6 parts to the part number | | | | | |
| Prefix | Size | Face Code | Hole Pattern | Hole Type | Accuracy |
| CUBE | .50 | A thru K (See Face Table) | (blank) or 1 thru 4 (See Hole Pattern Chart) | (blank) or | 1 SEC* |
| | .75 | | | S=Fine Thrd | 3 SEC* |
| | 1.0 | | | T=Coarse Thrd | 5 SEC |
| | 1.5 | | | U=Thru Hole | 10 SEC |
| | 2.0 | | | V=Thru Hole with C-Sink Y=C' Bore thru hole (See Hole Pattern Chart for available dimensions) | |

*Not Available In 0.50" Size

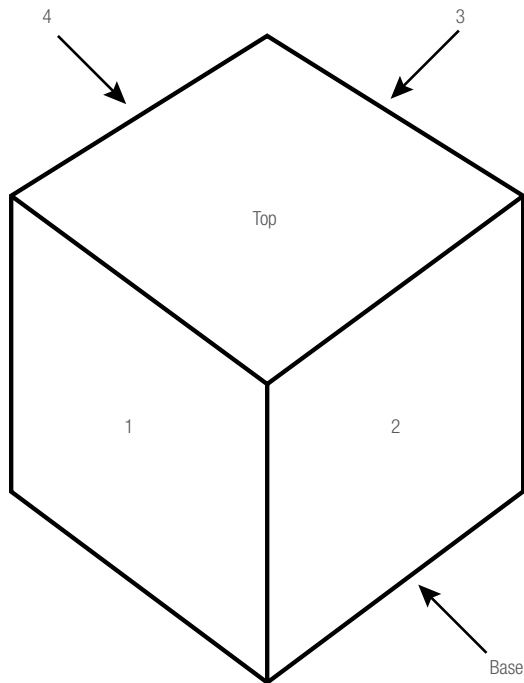

Cubes are made to order from semifinished blanks in six standard sizes: 0.50" (12.7mm), 0.75" (19.0mm), 0.95" (24.1mm), 1.00" (25.4mm), 1.50" (38.1mm), and 2.00" (50.8mm). Also available is a .950" (24.1m) square with a 17/64" (6.7mm) countersunk center hole.

Example: CUBE 1.0 A 3SEC

CUBE 1.0 = 1" Cube
 A = finished 6 sides
 1SEC = orthogonal to 3 second accuracy.
 (No holes were specified in this example.)

Reflectivity of finished faces is nominally:
 Visible Blue Light ($\lambda = 4200 \text{ \AA}$) $\approx 50\%$
 Visible Red Light ($\lambda = 6900 \text{ \AA}$) $\approx 60\%$
 Infrared ($\lambda = 10.6 \mu\text{m}$) $> 80\%$
 We are unable to measure or certify reflectivity. If reflectivity testing is required, the user must arrange for testing through a third party.

| Face Code Table | | |
|-----------------|-----------------------|----------------|
| Face Code | No. of Finished Faces | Finished Faces |
| A | 6 | ALL |
| B | 5 | 1-2-3-4-Base |
| C | 5 | 1-2-3-Top-Base |
| D | 4 | 1-2-3-Base |
| E | 4 | 1-3-Top-Base |
| F | 4 | 1-2-Top-Base |
| G | 3 | 1-3-Base |
| H | 3 | 1-2-Base |
| J | 3 | 1-Top-Base |
| K | 2 | 1-Base |



Hole Pattern Dimensions and Hole Types

Dimensions are shown in Inches.

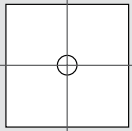
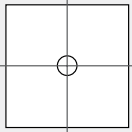
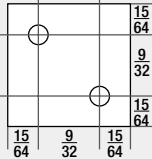
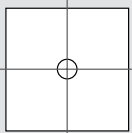
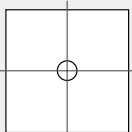
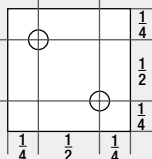
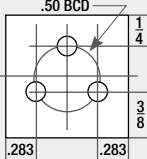
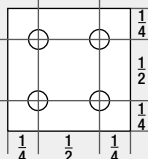
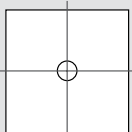
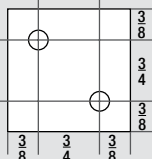
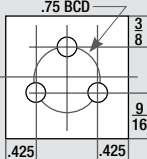
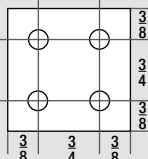
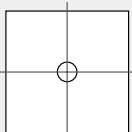
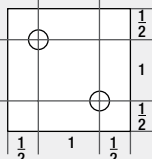
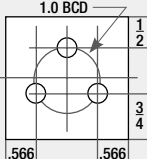
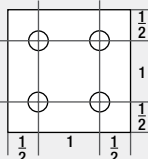
| | Hole Pattern-1 | Hole Pattern-2 | Hole Pattern-3 | Hole Pattern-4 |
|-----------------|--|--|--|--|
| CUBE .50 |  <p>Min. Good Thread .28 T1 S1 T2 S2 U0 U1 U2 U3 V0 V1 C'Bore Depth = .20" Y0 Y1 Y2</p> | | | |
| CUBE .75 |  <p>Min. Good Thread .40 T1 S1 T2 S2 U1 U2 U3 U4 V1 V2 V3 V4 C'Bore Depth = .38" Y1 Y2 Y3</p> |  <p>Min. Good Thread .40 T1 S1 T2 S2 U1 U2 U3 C'Bore Depth = .38" Y1</p> | | |
| CUBE .95 |  <p>.266 Dia. Thru Hole 72° C-Sink. Min. 100° Deep for #8 Flat Head Screw</p> | | | |
| CUBE 1.0 |  <p>Min. Good Thread .50 T2 S2 T3 S3 T4 S4 U2 U3 U4 V2 V3 V4 C'Bore Depth = .50" Y2 Y3 Y4</p> |  <p>Min. Good Thread .50 T2 S2 T3 S3 U2 U3 U4 C'Bore Depth = .50" Y2</p> |  <p>.50 BCD Min. Good Thread .50 T2 S2 T3 S3 U2 U3 U4 C'Bore Depth = .50" Y2</p> |  <p>Min. Good Thread .50 T2 S2 T3 S3 U2 U3 U4 C'Bore Depth = .50" Y2</p> |
| CUBE 1.5 |  <p>Min. Good Thread .62 T3 S3 T4 S4 U3 U4 U5 V3 V4 V5 C'Bore Depth = .75" Y3 Y4 Y5</p> |  <p>Min. Good Thread .62 T3 S3 T4 S4 U3 U4 U5 V3 V4 Y3 Y4</p> |  <p>.75 BCD Min. Good Thread .62 T3 S3 T4 S4 U3 U4 U5 V3 V4 C'Bore Depth = .75" Y3 Y4</p> |  <p>Min. Good Thread .62 T3 S3 T4 S4 U3 U4 U5 V3 V4 Y3 Y4</p> |
| CUBE 2.0 |  <p>Min. Good Thread .75 T3 S3 T4 S4 U4 U5 U6 V3 V4 V5 C'Bore Depth = 1.25" Y4 Y5</p> |  <p>Min. Good Thread .75 T3 S3 T4 S4 U4 U5 U6 V3 V4 V5 C'Bore Depth = 1.25" Y4 Y5</p> |  <p>1.0 BCD Min. Good Thread .75 T3 S3 T4 S4 U4 U5 U6 V3 V4 V5 C'Bore Depth = 1.25" Y4 Y5</p> |  <p>Min. Good Thread .75 T3 S3 T4 S4 U4 U5 U6 V3 V4 V5 C'Bore Depth = 1.25" Y4 Y5</p> |

Legend for Hole Types

| Threaded Hole | | Thru Hole | 72° Countersunk Hole | Counterbore Hole for Cap Head Screw | |
|---------------|-------------|---------------------------------|---------------------------------|-------------------------------------|----------------------|
| T1 = 6-32 | S1 = 6-40 | U0 = 0.128 Dia. for #4 Screw | V0 = 0.128 Dia. for #4 Screw | Y0 = for #4 Screw | 0.128 Dia. Thru Hole |
| T2 = 8-32 | S2 = 8-36 | U1 = 0.156 Dia. for #6 Screw | V1 = 0.156 Dia. for #6 Screw | Y1 = for #6 Screw | 0.21 Dia. C'Bore |
| T3 = 10-24 | S3 = 10-32 | U2 = 0.180 Dia. for #8 Screw | V2 = 0.180 Dia. for #8 Screw | Y2 = for #8 Screw | 0.180 Dia. Thru Hole |
| T4 = 1/4-20 | S4 = 1/4-28 | U3 = 0.206 Dia. for #10 Screw | V3 = 0.206 Dia. for #10 Screw | Y3 = for #10 Screw | 0.29 Dia. C'Bore |
| | | U4 = 0.266 Dia. for 1/4" Screw | V4 = 0.266 Dia. for 1/4" Screw | Y4 = for 1/4" Screw | 0.206 Dia. Thru Hole |
| | | U5 = 0.328 Dia. for 5/16" Screw | V5 = 0.328 Dia. for 5/16" Screw | Y5 = for 5/16" Screw | 0.34 Dia. C'Bore |
| | | U6 = 0.391 Dia. for 3/8" Screw | | | 0.266 Dia. Thru Hole |
| | | | | | 0.40 Dia. C'Bore |
| | | | | | 0.332 Dia. Thru Hole |
| | | | | | 0.50 Dia. C'Bore |

Tolerances are ± .010" except for Counterbore depth: ± .020"

Example: CUBE 1.5 D 2 Y4 1SEC

CUBE 1.5 = 1-1/2" Cube

D = finished front, right, and base

2 = two holes located in corners of the cube (See Pattern Table for hole location)

Y4 = .266 Dia. thru hole with .40 Dia C'Bore for 1/4" cap screw

For 1.5" cube, C'Bore depth = .75" (See Pattern Table)

1SEC = finished sides orthogonal to 1 second accuracy



OPTICAL

OPTICAL POLYGONS

Webber Optical Polygons provide an easy, accurate method of checking and calibrating angles. They are designed for use with autocollimators in measuring angle spacing.

The exclusive one-piece design provides compact, fixed master for precise angle spacing. Target faces are highly reflective and optically flat.

Chrome carbide polygons provide a hardness of Rockwell 71-73 C and a corrosion resistance 10-20 times that of 18-8 stainless steel, resulting in lifetime accuracy.

Maintenance problems are virtually eliminated due to their ruggedness and extreme stability.

A 1" mounting hole, flanged bushing, lapped washer and hold-down bolt, furnished with each unit, permit mounting the polygon in any desired attitude. Available in two accuracy grades. Furnished in case. Certificate of Calibration included.



Optical Polygon

| Optical Polygon Specifications | | | | | | |
|--------------------------------|-----------------------|---------------------------------|-------------------|----------------------------|--------------|--------------|
| No. of Sides | Angle Spacing Degrees | Diameter Across Corners in (mm) | Height in (mm) | Target Size in (mm) | Area Sq. In. | Area Sq. Cm. |
| 3 | 120 | | | | | |
| 4 | 90 | | | | | |
| 5 | 72 | | | | | |
| 6 | 60 | 2.90" (73.6mm) | .880" (22.3mm) | .75" x .75" (19 x 19mm) | .56 | 3.60 |
| 8 | 45 | | | | | |
| 9 | 40 | | | | | |
| 10 | 36 | | | | | |
| 12 | 30 | | | | | |

To order polygons, specify number in the following key/sequence:

Optical Polygon OP
No./Faces
Decimal
Accuracy Grade

Example: OP 3.0 = A 3-sided optical polygon with a 0 Reference Accuracy

| Optical Polygon Specifications | | | |
|--------------------------------|-----------------------|---------------------------------------|--|
| Accuracy Grade | Target Area Flatness* | Accuracy of Calibration (Uncertainty) | Maximum Deviation of Faces from Nominal 3-12 |
| Reference: 0 Calibration: 1 | 4 μin. (.10 μm) | ±1.0 sec. | ±1.0 sec. ±2.0 sec. |

* Excludes .020" (0.5mm) from edges.

All sizes: Flatness and parallelism – top and bottom – .00005"; maximum pyramidal error ±15 seconds.

FUSED QUARTZ OPTICAL FLATS



Fused Quartz Opticla Flat

For visually checking the flatness of seals, gages and mating surfaces. Through means of interpreting light interference patterns or bands, the optical flat provides a simple, accurate precision method for measuring surface flatness. Flats are crafted from high quality fused quartz and provide the maximum resistance to wear, damage and temperature variations.

Starrett-Webber optical flats are available in single or double surfaces and three accuracy grades. The double flat has both surfaces finished to tolerance but not necessarily parallel. Double flats provide longer service because wear is distributed over two surfaces. All are furnished with case.

Coating is available and it aids readability when applied to one surface. Coating is of value on single-sided flats only. Coating on a double surface will reduce the readability of the other surface.

When ordering, specify size, accuracy grade, single or double side, and coated or not.

| Fused Quartz Optical Flats, Accuracy Grades | |
|---|-----------------|
| Reference Grade | 1 μin. (.03 μm) |
| Master Grade | 2 μin. (.05 μm) |
| Working Grade | 4 μin. (.10 μm) |

| Fused Quartz Optical Flats, Standard Sizes* | | |
|---|--------------------------|-----------------------|
| 1 x 1/2" (25 x 12.7mm) | 3 x 11/16" (75 x 17.5mm) | 5 x 7/8" (125 x 22mm) |
| 2 x 5/8" (50 x 16mm) | 4 x 3/4" (100 x 19mm) | 6 x 1" (150 x 25mm) |

* Dimensions shown in millimeters are approximate.

Larger sizes available on special order.

Optical flats are made to U.S. Federal Specifications GG-O-635. Certificate of Calibration available at extra cost. Accuracy of Calibration (uncertainty) 3μin. (0.08μm).





CHAMOIS

These Starrett-Webber synthetic chamois cloths, rather than natural chamois, are recommended for wiping gage surfaces. They can be used with solvents and oils, including Starrett M-1® All-Purpose Lubricant, and are washable in detergents.

| Chamois | |
|----------|-------------|
| Cat. No. | Description |
| CH 1. | Dry |
| CH 2. | Lubricated |

CH 1.

GAGE BLOCK STONES

If a block does not wring together with other blocks, it may be the result of nicks or other damage. Examine blocks carefully with a magnifying glass. If a small burr is found, it may be removed with a gage block stone.

Starrett-Webber stones, when used moderately, may be rubbed directly on the gaging surfaces without danger of decreasing the size of the gage block. Available in 3 styles/ materials as listed.

GS 13 is recommended for use with steel gage blocks

SAO 13 is recommended for general use. Steel, ceramic, or carbide blocks

SAO 23 is recommended for use with carbide and ceramic gage blocks



Gage Block Stones

| Gage Block Stones | | |
|-------------------|--------------------|--|
| Cat. No. | For Block Material | Description |
| GS 13. | Steel | Black Granite Stone, 1/4 x 1 x 3" (6.3 x 25 x 75mm) |
| SAO 13. | | Sintered Aluminum Oxide, 5/16 x 1 x 3" (8 x 25 x 75mm) |
| SAO 23. | Steel or Carbide | Serrated Aluminum Oxide with Case, 1 x 2 x 3" (25 x 50 x 75mm) |





NVLAP LAB CODE 200038-0

ACCREDITED GAGE BLOCK CALIBRATION SERVICE

In accordance with: ISO 17025
ANSI/NCSL Z540-1
ISO 10012-1
former MIL-STD-45662A

MASTER CALIBRATION

The calibration procedure is regarded as a process to be controlled and monitored using SPC techniques. Information that would enable the analysis of control data is to be recorded and can be made available to the user upon request (at extra cost). A second master, sometimes referred to as a control block, is used in the calibration. The purpose of the second master is to generate known difference reading which can be analyzed. The average of the known differences of several readings of the two masters and the range of their differences can be analyzed using statistical techniques. The calibration process can be demonstrably controlled.

Reported measurement uncertainties based upon a 95% confidence level (two standard deviations) are dynamic, reflecting the current performance of the specific equipment and operator. Other factors included in the stated uncertainty are derived from a detailed error analysis. The error analysis is based upon experimentation whenever possible or industry consensus from estimates derived from NIST publications. Experimental checks of the stated uncertainty levels are made using laboratory comparison techniques involving both internal repeatability studies and external comparisons with other calibration laboratories.

Our Reference Gage Blocks are calibrated directly by NIST. All other reference standards are periodically checked and calibrated either by NIST or NVLAP accredited laboratories. Documented histories are maintained. Statistical methods are used to control all of our master gages.

NOTICE: Webber Gage cannot recommend recalibration due dates on our calibration certificates or calibration stickers. Recalibration due dates must be provided to us at the time of order. If this information is not provided, the recalibration due date will be left blank for the user to add.

LABORATORY CALIBRATION

Each block calibrated using our Laboratory Calibration procedure is calibrated three times using our Master Calibration procedure as described above - Using different transfer master blocks, operators and equipment when possible for all three measurements. The results are averaged together and reported. This results in the lowest possible uncertainty reported to the user as random errors in the measuring process are averaged out.

This calibration service is restricted to Webber rectangular croblock[®] gage blocks of Webber grades LM or AA, GGG grades 0.5 and 1, and B89 grades 00 and K.

COMMERCIAL CALIBRATION

Calibrations are performed using the same program as our Master calibrations except that the second master, the control block, is omitted. By omitting this control block some of the statistical tests are also omitted which results in larger uncertainty.

All necessary information to confirm the calibration is recorded. All raw data from the comparator, the temperature of the blocks, the temperature of the comparator, and the relative humidity of the surrounding environment is recorded for each measurement. Applied correction factors are broken down and are recorded, as well as the results of any calibrations.

Our Reference Gage Blocks are calibrated directly by the National Institute of Standards and Technology. All other reference standards are calibrated either by NIST or NVLAP accredited laboratories. Documented histories are maintained of our measuring and test equipment. Statistical methods are used to control our Master Gage Blocks.

Reported uncertainties are based on a 95% confidence level. Experimental checks of the uncertainty are made using laboratory comparison techniques involving repeatability studies and external comparisons with other calibration laboratories.

Approximate Best Uncertainty (k=2) for blocks through 4" (100mm) in length

| Grade | Commercial Calibration | | Master Calibration | | Laboratory Calibration | |
|-----------------|------------------------|---------|--------------------|---------|------------------------|---------|
| | Uncertainty | Minimum | Uncertainty | Minimum | Uncertainty | Minimum |
| Webber LM | | | | | 0.65 + 0.7L | 1.4µin |
| GGG 0.5 | | | | | .016 + .0007L | .035µm |
| Webber AA | | | | | | |
| B89 Grade 00, K | 1.6 + 1.0L | 2.4 µin | 1.2 + 0.7L | 1.7µin | 0.65 + 0.7L | 1.4µin |
| GGG 1 | .04 + .001L | .060µm | .03 + .0007L | .045µm | .016 + .0007L | .035µm |
| Webber A1 | | | | | | |
| B89 Grade 0 | 2.0 + 1.0L | 3.0 µin | 1.8 + 0.7L | 2.0µin | | |
| GGG 2 | .05 + .001L | .075µm | .045 + .0007L | .050µm | | |
| B89 Grade AS1 | 2.0 + 1.0L | 3.0 µin | 1.8 + 0.7L | 2.0µin | | |
| GGG 3 | .05 + .001L | .075µm | .05 + .0007L | .050µm | | |

NVLAP[®] accreditation does not constitute an endorsement of any product by NVLAP[®] or any agency of the U.S. Government.



STARRETT-WEBBER GAGE CALIBRATION

GAGE BLOCK CALIBRATION SERVICES

We offer expert and comprehensive gage block calibration and repair services for Starrett-Webber gage blocks.

Calibration will help you prevent production inaccuracies. It will identify a worn gage block before it can create a problem. Regular, periodic calibration of your gage blocks will ensure that your gage blocks are as accurate and dependable as when they were new.

COMPREHENSIVE AND FAST

Starrett-Webber gage block calibration is performed promptly – your gage blocks will be ready to be returned to you within a few days after we receive them.

The calibration process is as follows:

1. After receiving your gage blocks, we document their arrival, then clean each block to remove oil, grease and film. The case is also thoroughly cleaned.
2. Next, we lightly stone each block to remove small nicks and burrs. This does not guarantee that the blocks will wring if they are heavily nicked, scratched, or burred.
3. Your gage blocks are then individually compared with master blocks that are accurate to fractions of one millionth of an International Inch. Starrett-Webber Grand Master Blocks are Starrett-Webber croblox® (solid chrome carbide). Our exclusive Grand Master Gage Blocks are calibrated directly by the U.S. National Institute of Standards and Technology (NIST).
4. Our automated system generates a Certificate of Calibration to ensure complete accuracy in recording gage block size. This certificate shows the deviation from the marked size of each block and marks those sizes which need replacing.
5. We will then provide a quotation for recommended replacements in the original material and croblox, if applicable.
6. If replacements are not required, or if you have instructed us only to calibrate and return the set, the gage blocks are packed and returned to you with a Certificate of Calibration showing the "as found" readings.
7. If you authorize replacements, your Certificate of Calibration is marked to indicate which blocks were replaced and the date of replacement. At your request, we can issue an "as found" and an "as left" certificate for an additional fee.

PLEASE PROVIDE THE FOLLOWING INFORMATION:

When sending gage blocks to us for calibration, please specify whether you want us to:

- A. Calibrate, issue a certificate and return only;
- B. Calibrate, advise condition and hold for instructions; or
- C. Calibrate, replace worn and missing blocks, then return.

If your order specifies replacement for worn and missing blocks and the cost of replacement approaches that of a new set, we will inform you, provide a quote price and wait for your instructions.

BE SURE TO PROTECT YOUR VALUABLE GAGE BLOCKS BY PACKAGING THEM CAREFULLY

Gage block cases are made for immobile storage – not as shipping crates.

It is good practice to carefully follow these steps when preparing your gage blocks for shipment:

- Treat them with rust preventative. Starrett M1® Lubricant is an excellent choice for this job.
- Place wax paper over the blocks.
- If necessary, add cushioning inside lid to prevent excessive movement of blocks in the inserts. Do not overdo this – the lid should not have to be forced to close.
- Seal the closed case with reinforced heavy tape. Note that the case clasp alone is not adequate to ensure that the case remains closed during shipment.
- Use a strong, oversize outer shipping container. Carefully surround the case with a generous amount of firm cushioning material to ensure that your blocks withstand shock in transit.
- Be sure to mark the shipping box as "Fragile."

AS GOOD AS NEW

When you receive your freshly calibrated gage block set with all necessary of the recommended repairs and/or replacements, you can rely on them to be essentially as good as new – that is, the most reliable and trusted gage blocks available – Starrett-Webber.





PRECISION MAKES THE DIFFERENCE

**bi-metal
unique®**

YOUR NAME DEPENDS ON OURS

Starrett Unified Shank jig saws incorporate the Starrett exclusive bi-metal unique® process technology. Blades made from this process resist breakage, cut faster and last longer than conventional saws.



Starrett®

(978) 249-3551 • starrett.com

Follow us!





PRECISION GRANITE PRODUCTS

175 FRODOE DRIVE, WAUKEGAN, ILL. 60087
Serial: 307528 Grade: 000-918-0117

GRANITE SURFACE PLATES AND ACCESSORIES

In 2006, The L.S. Starrett Company acquired Tru-Stone Technologies in Waite Park, MN. With this acquisition, a broad variety of new capabilities are now available to Starrett customers.

OEM CAPABILITIES

Our Starrett Tru-Stone Granite Division continues to provide solutions to customers in precision granite, carbon fiber, ceramic, high precision vacuum chucks and other materials. We offer granite machine bases and surface plates to meet your requirements up to 55 feet long and weighing 72 tons.

Whether your application requires a simple standard surface plate or a large OEM assembly, the Starrett Tru-Stone Division will work with you to fulfill those requirements.

Every linear measurement depends on an accurate reference surface from which final dimensions are taken. Starrett Precision Granite Surface Plates provide this reference plane for work inspection and for work layout. Their high degree of flatness, overall quality and workmanship also make them ideal bases for mounting sophisticated mechanical, electronic and optical gaging systems.

MATERIAL

The granite for Starrett surface plates has been selected for the best balance of physical properties, maximum resistance to wear and for deflection under load. Each plate has been lapped to a fine microinch finish to minimize tool wear and drag.

The most important element in the performance and life of granite surface plates is the percentage of quartz that is present in the stone. Quartz is more than twice as resistant to wear as the other minerals in granite. It provides bearing points that are of a hard, highly polished, smooth character which protect the accuracy and finish of both the surface plate and the tools and instruments used on it.

Starrett Crystal Pink® Granite has the highest percentage of quartz of any granite. Higher quartz content means greater wear resistance. The longer a surface plate holds its accuracy, the less often it will require resurfacing, ultimately providing better value.

SELECTION

ACCURACY UNDER LOAD

Starrett Crystal Pink® and Superior Black Granite plates have a thickness capable of supporting a total normal load equal to 50lb for each square foot (24kg for each 1,000 sq. cm) of surface area loaded in the center of the plate – without deflecting the plate along a diagonal of more than one-half the flatness tolerance. This is the accepted rating in the U.S. Federal Specification GGG-P-463c and ASME B89.3.7 2013.

In the situations where abnormal loading conditions are anticipated, Starrett can engineer and modify surface plate thickness to meet virtually any requirement.

LEDGES AND CLAMPING

Surface plates without work clamping ledges are recommended for sustained accuracy and reliability. Ledges are for work clamping purposes only. If excessive torque is used when applying clamps to ledges, it can adversely affect measurements taken near the plate edges. If clamping is important, T-slots and threaded metal inserts may be installed in the surface.

ACCURACY

SPECIFICATIONS

Starrett Granite Surface Plates meet or exceed U.S. Federal Specification GGG-P-463c and ASME B89.3.7 2013.

STARRETT GRANITE SURFACE PLATE CALIBRATION SERVICES

- Calibration of granite surface plates, granite parallels (2 and 4-sided), granite straight edges, granite tri-squares, granite angle plates and granite squares
- Surface plate and granite metrology and accessory resurfacing
- Calibration Lab is accredited by A2LA to ISO/IEC 17025*

* The L.S. Starrett Company's accreditations are site-specific and tool-specific. The scope of accreditation is available upon request to each location.



TECHNICAL INFORMATION

ACCURACY

Granite Surface Plates are manufactured in three grades of accuracy:

- Grade AA – Laboratory Grade**
 This is typically specified for precision operations in constant temperature gaging rooms and metrology departments.
- Grade A – Inspection Grade**
 This is typically specified for general work in quality control.
- Grade B – Toolroom Grade**
 This is typically specified for production checking work throughout the shop.

UNILATERAL FLATNESS TOLERANCE

Overall flatness tolerance is based on unilateral measurement. All points on the work surface shall be contained between two parallel planes separated at a distance no greater than the amount specified for each particular grade and size as shown in our listings.

REPEAT READING TOLERANCE

Repeat reading tolerance is easily checked with a Repeat Reading Gage. This gage detects local areas, not overall flatness.

In addition to the overall flatness tolerance referred to above, Starrett provides repeat reading tolerances as follows:

| Diagonal Inches (mm) | Full Indicator Movement (F.I.M.) in Microinches and (Microns) | | | Obtained |
|---------------------------|---|-----------|-----------|--------------------|
| | Grade AA | Grade A | Grade B | |
| Through 30" (750) | 35 (.9) | 60 (1.5) | 110 (2.8) | When Not Specified |
| Over 30-60" (750-1500) | 45 (1.1) | 70 (1.8) | 120 (3) | |
| Over 60-90" (1500-2250) | 60 (1.5) | 80 (2) | 160 (4) | |
| Over 90-120" (2250-3000) | 75 (1.9) | 100 (2.5) | 200 (5) | |
| Over 120-150" (3000-3800) | 90 (2.3) | 120 (3) | 240 (6) | |
| Over 150" (3800) | 100 (2.5) | 140 (3.6) | 280 (7) | |
| All Sizes | 25 (.6) | 50 (1.3) | 100 (2.5) | When Specified |

A repeat reading gage detects minute variations of the surface within the unilateral flatness tolerance of the whole surface.

CERTIFIED ACCURACY

Before shipment, each surface plate must pass a critical final inspection to prove that its entire surface is within the specified tolerance. The final inspection is done with an autocollimator in a controlled environment. This instrument is checked and certified against standards traceable to the U.S. National Institute of Standards and Technology (NIST). The instrument's certification is on file at the Starrett Tru-Stone Technologies Division in Waite Park, MN.

All shipments of Starrett precision granite products include a calibration certificate which verifies traceability to NIST as well as certifying that the inspection requirements of U.S. MIL-I-45208A and Federal Spec. GGG-P-463c and ASME B89.3.7 2013 have been met.

PERIODIC INSPECTION

Every surface plate in use should be frequently inspected, especially when used in shop conditions where abrasion is common. An effective inspection program should include regular checks with an autocollimator. If tolerance variations are excessive, the plate can be transferred to work involving less accuracy or it can be resurfaced to restore its original level of accuracy.

RESURFACING SERVICES

Resurfacing for Starrett and other brands of granite surface plates are available in our plant or yours.

DESIGN ASSISTANCE

Starrett engineers will provide prompt assistance with any problem related to surface plate design, installation or use. Our staff is available to assist in your design of larger OEM projects.

To get the best service and value from any granite plate, contact Starrett Tru-Stone.



Inspecting a granite plate with an autocollimator



GRANITE SOLUTIONS

CUSTOM ENGINEERED GRANITE SOLUTIONS FOR OVERSIZE PARTS AND ASSEMBLING

Starrett has unparalleled experience and expertise in building special, extra-large granite surface plates and custom products from granite to meet specific requirements.

All Starrett special surface plates are made from single, solid slabs of granite quarried in one piece, machined in one piece and finished to your specified dimensions and tolerances.

SPECIAL PLATES ARE USUALLY REQUESTED IN TWO CATEGORIES:

INSPECTING OVERSIZE PARTS:

The first category is for inspecting oversize parts and assemblies such as diesel engine blocks and crankshafts, vehicle frames, missile components and ground support equipment.

Inquiries for granite surface plates to accommodate oversize parts and assemblies should indicate:

1. Type of part to be staged
2. Distribution of weight
3. Inspection accuracy required
4. Work holding requirements
5. Footing requirements, ceiling height and availability of heavy-duty work-handling equipment

MODIFYING STANDARD PLATES:

The second general category relates to modifying standard plates or building special surface plates for work-holding attachments of many different types.

Threaded and solid inserts, adapter holes, T-slots, dovetails – almost anything added to conventional gaging fixtures can also be added to Starrett surface plates, extending their accuracy and versatility for numerous applications. Precision edges, made square with the top surface and adjacent edges, as well as precision graduated rules can also be added.

We can build and assemble this work-holding or special gaging equipment to very close tolerance in either fractional, decimal inch or metric dimensions. All special plates are quoted on an individual basis, based on complexity and tolerance requirements. We will work with you to give you the best, most economical solution for your application.

The uses of Starrett special granite surface plates are limited only by the imagination of the creative tool designer. Inquiries for special surface plates like the type shown will be studied and recommendations given without obligation.



We can build custom fixture plates that provide exceptional positional accuracy for one or several of your applications

TRU-VAC VACUUM AND AIR-LIFT TECHNOLOGY

Starrett provides both standard and custom solutions for vacuum chucking, positioning or air-lift part transfer. Our innovative Tru-Vac technology integrates the stability and precision flatness of granite with a porous medium, usually ceramic.

Tru-Vac can eliminate the need for mechanical clamping with its inherent part distortion or damage risk by utilizing vacuum draw at specific locations or distributed over the entire surface of your part.

Conversely, Tru-Vac technology can be utilized to provide positive pressure to allow delicate parts to glide on a cushion of air from which they can be safely lifted or transferred to the next operation.

Starrett engineers will work with you to select the best porous medium for your application based on surface area, flatness, wear, and desired airflow characteristics.

Tru-Vac technology can be utilized in air chucks smaller than a hockey puck or larger than a conference room table. Vacuum zones can be of nearly any shape by virtue of our CNC milling capabilities.

Multiple zones can be utilized to accommodate a variety of part sizes or even to provide a combination of negative and positive pressure for controlled part movement.

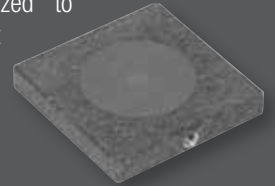

Tru-Vac Vacuum Chuck



Starrett offers unparalleled design expertise and experience to work with your engineers to create the ideal custom solution for your application



TECHNICAL CAPABILITIES

Starrett has a variety of technical capabilities that, combined with our expertise, makes us the perfect choice for your custom granite requirements.

These capabilities include:

- Drilled and bored holes with precise size and location (right)
- Inserts turned and inspected in-house for quality control and custom options
- T-slots and inserts bonded using proprietary methods
- CNC milling of patterns of clearance areas
- Specialty slot milling capabilities
- Unsurpassed dimensional control of flat, square, and parallel surfaces

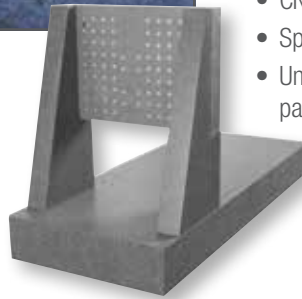

EXAMPLES OF CUSTOM APPLICATIONS CAPABILITIES

Above: High-accuracy, CNC-drilled holes and milled contours

Right: Clean room assembly

Left: Extremely large (or small) part capabilities.

ASSEMBLY INTEGRATION

In addition to collaborating on the design and building of your machine foundation, Starrett technicians are skilled at value-added assembly.



Using precision equipment in our assembly laboratories, we can provide you with the next level assembly, such as adding bearing rails, encoder rails, screw drives, stages, or vibration damping devices.

Having this assembly done at our factory provides accountability for accurate performance.



GRANITE SURFACE PLATES



Crystal Pink Granite Surface Plate

CRYSTAL PINK®

- Accurate for use in metrology laboratories and wear resistant for use in abrasive shop environments
- The finest, most durable granite surface plate available to industry today
- The name is derived from the fact that it has the highest crystalline quartz content of any granite surface plate

SURFACE FINISH

- Even distribution of large quartz crystals provides a smooth finish, which significantly reduces wear on the surface plate and the instruments used on it
- Fine micro-finish, combined with the natural voids in the surface provides a velvety-smooth tool action

WEAR LIFE

- Non-quartz-bearing granite in average daily use requires resurfacing about once a year, while Crystal Pink plates used in these same plants have required resurfacing only once every three to five years, on average.

STARRETT CRYSTAL PINK:

- Meets or exceeds U.S. Federal Specification GGG-P-463c and ASME B89.3.7 2013 for overall flatness, local area flatness and accuracy under load
- Great surface hardness and wear resistance – the highest percentage of quartz crystals of any granite plate
- Smooth, jewel-like quartz bearing points protect accuracy and finish of both the surface and the tools used on it
- Quality and economy combined
- Comparable to black granite plates while outwearing them as much as 5 to 1
- Meets or exceeds 50 lb per square foot (24kg per 1,000 sq. cm) load bearing specifications. Available in 100 lb (45kg) test series.
- Standard-size plates are mounted on resilient support pads, providing isolation from normal vibration and a non-distorting 3-point suspension.
- Packed one per crate with skids for forklift handling.



| Grade AA Laboratory | | | | | | No Ledge | | | Two Ledge | | |
|---------------------|-------------|-----------|-----|-------------------------------|--------|----------|------|-------|-----------|------|-------|
| Surface Size | | Thickness | | Flatness Unilateral Tolerance | | Weight | | | Weight | | |
| in | mm | in | mm | in | mm | lb | kg | EDP | lb | kg | EDP |
| 12 x 12 | 300 x 300 | | | | | 55 | 25 | 80601 | 50 | 23 | 80602 |
| 12 x 18 | 300 x 450 | 4 | 100 | .000050 | 0.0012 | 85 | 39 | 80610 | 78 | 35 | 80611 |
| 18 x 18 | 450 x 450 | | | | | 125 | 57 | 80619 | 120 | 54 | 80620 |
| 18 x 24 | 450 x 600 | | | | | 248 | 113 | 80628 | 224 | 102 | 80629 |
| 24 x 24 | 600 x 600 | 6 | 150 | .000075 | 0.0019 | 330 | 150 | 80646 | 306 | 139 | 80647 |
| 24 x 36 | 600 x 900 | 6 | 150 | .000100 | 0.0025 | 495 | 225 | 80655 | 460 | 209 | 80656 |
| 30 x 48 | 750 x 1200 | 10 | 250 | .000168 | 0.0043 | 1585 | 719 | 80883 | 1585 | 719 | 80884 |
| 36 x 36 | 900 x 900 | 6 | 150 | .000150 | 0.0038 | 745 | 338 | 80701 | 710 | 322 | 80702 |
| 36 x 48 | 900 x 1200 | 8 | 200 | .000200 | 0.0050 | 1320 | 599 | 80710 | 1250 | 567 | 80711 |
| 36 x 60 | 900 x 1500 | 10 | 250 | .000250 | 0.0063 | 2065 | 937 | 80719 | 1950 | 885 | 80720 |
| 36 x 72 | 900 x 1800 | 12 | 300 | .000300 | 0.0076 | 2970 | 1347 | 80728 | 2810 | 1275 | 80729 |
| 48 x 48 | 1200 x 1200 | 10 | 250 | .000200 | 0.0051 | 2535 | 1150 | 80889 | 2535 | 1150 | 80890 |
| 48 x 72 | 1200 x 1800 | 12 | 300 | .000350 | 0.0088 | 3960 | 1796 | 80755 | 3795 | 1721 | 80756 |
| 48 x 96 | 1200 x 2400 | 16 | 400 | .000500 | 0.0127 | 7040 | 3193 | 80773 | 6750 | 3062 | 80774 |
| Grade A Inspection | | | | | | No Ledge | | | Two Ledge | | |
| Surface Size | | Thickness | | Flatness Unilateral Tolerance | | Weight | | | Weight | | |
| in | mm | in | mm | in | mm | lb | kg | EDP | lb | kg | EDP |
| 12 x 12 | 300 x 300 | | | | | 55 | 25 | 80604 | 50 | 23 | 80605 |
| 12 x 18 | 300 x 450 | 4 | 100 | .000100 | 0.0025 | 85 | 39 | 80613 | 78 | 35 | 80614 |
| 18 x 18 | 450 x 450 | | | | | 125 | 57 | 80622 | 120 | 54 | 80623 |
| 18 x 24 | 450 x 600 | 6 | 150 | .000150 | 0.0038 | 248 | 113 | 80631 | 224 | 102 | 80632 |
| 24 x 24 | 600 x 600 | | | | | 330 | 150 | 80649 | 306 | 139 | 80650 |
| 24 x 36 | 600 x 900 | 6 | 150 | .000200 | 0.0050 | 495 | 225 | 80658 | 460 | 209 | 80659 |
| 30 x 48 | 750 x 1200 | 8 | 200 | .000400 | 0.0102 | 1270 | 576 | 80885 | 1270 | 576 | 80886 |
| 36 x 36 | 900 x 900 | 6 | 150 | .000300 | 0.0076 | 745 | 338 | 80704 | 710 | 322 | 80705 |
| 36 x 48 | 900 x 1200 | 8 | 200 | .000400 | 0.0102 | 1320 | 599 | 80713 | 1250 | 567 | 80714 |
| 36 x 60 | 900 x 1500 | | | .000500 | 0.0127 | 2065 | 937 | 80722 | 1950 | 885 | 80723 |
| 36 x 72 | 900 x 1800 | 10 | 250 | .000600 | 0.0152 | 2475 | 1123 | 80731 | 2340 | 1061 | 80732 |
| 48 x 48 | 1200 x 1200 | 8 | 200 | .000500 | 0.0130 | 2030 | 921 | 80891 | 2030 | 921 | 80892 |
| 48 x 72 | 1200 x 1800 | 10 | 250 | .000700 | 0.0177 | 3300 | 1497 | 80758 | 3165 | 1436 | 80759 |
| 48 x 96 | 1200 x 2400 | 12 | 300 | .001000 | 0.0254 | 5280 | 2395 | 80776 | 5060 | 2295 | 80777 |
| Grade B Toolroom | | | | | | No Ledge | | | Two Ledge | | |
| Surface Size | | Thickness | | Flatness Unilateral Tolerance | | Weight | | | Weight | | |
| in | mm | in | mm | in | mm | lb | kg | EDP | lb | kg | EDP |
| 12 x 12 | 300 x 300 | | | | | 55 | 25 | 80607 | 50 | 23 | 80608 |
| 12 x 18 | 300 x 450 | 4 | 100 | .000200 | 0.0050 | 83 | 38 | 80616 | 76 | 34 | 80617 |
| 18 x 18 | 450 x 450 | | | | | 125 | 57 | 80625 | 118 | 54 | 80626 |
| 18 x 24 | 450 x 600 | 4 | 100 | .000300 | 0.0076 | 165 | 75 | 80634 | 155 | 70 | 80635 |
| 24 x 24 | 600 x 600 | | | | | 220 | 100 | 80652 | 210 | 95 | 80653 |
| 24 x 36 | 600 x 900 | | | .000400 | 0.0102 | 495 | 225 | 80661 | 460 | 209 | 80662 |
| 30 x 48 | 750 x 1200 | 6 | 150 | .000700 | 0.0180 | 950 | 431 | 80887 | 950 | 431 | 80888 |
| 36 x 36 | 900 x 900 | | | .000600 | 0.0152 | 745 | 338 | 80707 | 710 | 322 | 80708 |
| 36 x 48 | 900 x 1200 | | | .000800 | 0.0203 | 990 | 449 | 80716 | 955 | 433 | 80717 |
| 36 x 60 | 900 x 1500 | 8 | 200 | .001000 | 0.0254 | 1650 | 749 | 80725 | 1560 | 708 | 80726 |
| 36 x 72 | 900 x 1800 | | | .001200 | 0.0304 | 1980 | 898 | 80734 | 1870 | 848 | 80735 |
| 48 x 48 | 1200 x 1200 | 6 | 150 | .000900 | 0.0229 | 1520 | 689 | 80893 | 1520 | 689 | 80894 |
| 48 x 72 | 1200 x 1800 | 8 | 200 | .001400 | 0.0355 | 2640 | 1198 | 80761 | 2530 | 1148 | 80762 |
| 48 x 96 | 1200 x 2400 | 10 | 250 | .002000 | 0.0508 | 4400 | 1996 | 80779 | 4215 | 1912 | 80780 |

Other sizes available by request. No ledge and two ledge plates listed, four ledge plates available by request.

HOW TO ORDER

Specify:

1. Surface size of plate
2. Grade AA, A or B tolerance
3. Number of ledges

SPECIAL REQUIREMENTS

Should your application require something other than a standard surface plate, we can provide you with custom options.

Starrett can produce your plate from pink, black or gray granite. Custom sizes and thicknesses are available upon request to meet your needs.

We can also add holes, counterbores, threaded or solid stainless steel inserts and t-slots to your surface plate.

Contact Starrett Tru-Stone for assistance.



GRANITE SURFACE PLATES

SUPERIOR BLACK

Our superior black granite has low water absorption, thus minimizing the possibility of your precision gages rusting while setting on the plates.

This black granite creates little glare resulting in less eyestrain for individuals using the plates.

We have chosen our superior black granite with the specific intent of keeping thermal expansion to a minimum.



Superior Black Granite Surface Plate

SPECIAL REQUIREMENTS

Should your application require something other than a standard surface plate, we can provide you with custom options.

Starrett can produce your plate from pink, black or gray granite. Custom sizes and thicknesses are available upon request to meet your needs.

We can also add holes, counterbores, threaded or solid stainless steel inserts, and t-slots to your surface plate. Contact Starrett Tru-Stone for assistance.

HOW TO ORDER

Specify:

1. Surface size of plate
2. Grade AA, A or B tolerance
3. Number of ledges

| Grade AA Laboratory | | | | | | | | No Ledge | Two Ledge |
|---------------------|-------------|-----------|-----|-------------------------------|--------|--------|-------|----------|-----------|
| Surface Size | | Thickness | | Flatness Unilateral Tolerance | | Weight | | EDP | EDP |
| in | mm | in | mm | in | mm | lb | kg | | |
| 12 x 12 | 300 x 300 | 4 | 100 | .000050 | 0.0012 | 61 | 28 | 85006 | 85007 |
| 12 x 18 | 300 x 450 | | | 92 | 42 | 85010 | 85011 | | |
| 18 x 24 | 450 x 600 | | | 183 | 83 | 85028 | 85029 | | |
| 24 x 24 | 600 x 600 | | | .000075 | 0.0019 | 244 | 111 | 85036 | 85037 |
| 24 x 36 | 600 x 900 | 6 | 150 | .000100 | 0.0025 | 549 | 249 | 85055 | 85056 |
| 30 x 48 | 750 x 1200 | 8 | 200 | .000168 | 0.0043 | 1220 | 553 | 85082 | 85083 |
| 36 x 36 | 900 x 900 | 6 | 150 | .000150 | 0.0038 | 824 | 374 | 85090 | 85091 |
| 36 x 48 | 900 x 1200 | 8 | 200 | .000200 | 0.0050 | 1464 | 664 | 85110 | 85111 |
| 36 x 60 | 900 x 1500 | 10 | 250 | .000250 | 0.0063 | 2288 | 1038 | 85118 | 85119 |
| 36 x 72 | 900 x 1800 | 12 | 300 | .000300 | 0.0076 | 3294 | 1494 | 85128 | 85129 |
| 48 x 48 | 1200 x 1200 | 8 | 200 | .000200 | 0.0051 | 1952 | 885 | 85136 | 85137 |
| 48 x 72 | 1200 x 1800 | 10 | 250 | .000350 | 0.0088 | 3660 | 1660 | 85155 | 85156 |
| 48 x 96 | 1200 x 2400 | 12 | 300 | .000500 | 0.0127 | 5856 | 2656 | 85173 | 85174 |
| Grade A Inspection | | | | | | | | No Ledge | Two Ledge |
| Surface Size | | Thickness | | Flatness Unilateral Tolerance | | Weight | | EDP | EDP |
| in | mm | in | mm | in | mm | lb | kg | | |
| 12 x 12 | 300 x 300 | 4 | 100 | .000100 | 0.0025 | 61 | 28 | 85008 | 85009 |
| 12 x 18 | 300 x 450 | | | 92 | 42 | 85013 | 85014 | | |
| 18 x 24 | 450 x 600 | | | 183 | 83 | 85031 | 85032 | | |
| 24 x 24 | 600 x 600 | | | .000150 | 0.0038 | 844 | 111 | 85038 | 85039 |
| 24 x 36 | 600 x 900 | 6 | 150 | .000200 | 0.0050 | 549 | 249 | 85058 | 85059 |
| 30 x 48 | 750 x 1200 | | | .000400 | 0.0102 | 915 | 415 | 85085 | 85086 |
| 36 x 36 | 900 x 900 | | | .000300 | 0.0076 | 824 | 374 | 85092 | 85091 |
| 36 x 48 | 900 x 1200 | 8 | 200 | .000400 | 0.0102 | 1098 | 498 | 85113 | 85114 |
| 36 x 60 | 900 x 1500 | | | .000500 | 0.0127 | 1830 | 830 | 85120 | 85121 |
| 36 x 72 | 900 x 1800 | | | .000600 | 0.0152 | 2745 | 1245 | 85131 | 85132 |
| 48 x 48 | 1200 x 1200 | 6 | 150 | .000500 | 0.0130 | 1464 | 664 | 85138 | 85139 |
| 48 x 72 | 1200 x 1800 | 8 | 200 | .000700 | 0.0177 | 2928 | 1328 | 85158 | 85159 |
| 48 x 96 | 1200 x 2400 | 10 | 250 | .001000 | 0.0254 | 4880 | 2214 | 85176 | 85177 |
| Grade B Toolroom | | | | | | | | No Ledge | Two Ledge |
| Surface Size | | Thickness | | Flatness Unilateral Tolerance | | Weight | | EDP | EDP |
| in | mm | in | mm | in | mm | lb | kg | | |
| 12 x 12 | 300 x 300 | 3 | 75 | .000200 | 0.0050 | 46 | 21 | 85012 | 85015 |
| 12 x 18 | 300 x 450 | | | 69 | 31 | 85016 | 85017 | | |
| 18 x 24 | 450 x 600 | | | 136 | 62 | 85034 | 85035 | | |
| 24 x 24 | 600 x 600 | 4 | 100 | .000300 | 0.0076 | 244 | 111 | 85040 | 85041 |
| 24 x 36 | 600 x 900 | | | .000400 | 0.0102 | 366 | 166 | 85061 | 85062 |
| 30 x 48 | 750 x 1200 | | | .000700 | 0.0180 | 915 | 415 | 85088 | 85089 |
| 36 x 36 | 900 x 900 | 6 | 150 | .000600 | 0.0152 | 824 | 374 | 85094 | 85095 |
| 36 x 48 | 900 x 1200 | | | .000800 | 0.0203 | 1098 | 498 | 85116 | 85117 |
| 36 x 60 | 900 x 1500 | | | .001000 | 0.0254 | 1373 | 623 | 85122 | 85123 |
| 36 x 72 | 900 x 1800 | 8 | 200 | .001200 | 0.0304 | 2196 | 996 | 85134 | 85135 |
| 48 x 48 | 1200 x 1200 | 6 | 150 | .000900 | 0.0229 | 1464 | 664 | 85140 | 85141 |
| 48 x 72 | 1200 x 1800 | 8 | 200 | .001400 | 0.0355 | 2196 | 996 | 85161 | 85162 |
| 48 x 96 | 1200 x 2400 | | | .002000 | 0.0508 | 3904 | 1771 | 85179 | 85180 |

Other sizes available by request. No ledge and two ledge plates listed, four ledge plates available by request.



STANDS

SURFACE PLATE STANDS

Our stands are constructed from welded square steel tubing to provide exceptional strength and durability. Steel crossbeams are located at the proper support points to ensure maximum surface plate accuracy.

Stands are supplied with a scratch and abrasion resistant industrial powder coated finish. In addition to our standard beige gray color, other colors are available upon request and at an additional charge.

Stationary stands come with leveling adjusters with the typical adjustment being 2". Rolling stands are fabricated with two stationary and two swivel casters.

Stands require no assembly. Order by surface plate size.



Stationary Stand

Rolling Stand

| Surface Plate Stands | | | |
|-------------------------------------|--------|-------------------------------------|--------------------------|
| Surface Plate Size (Length x Width) | Weight | Stationary with Leveling Screws EDP | Rolling with Casters EDP |
| 12 x 18" | 50lb | 82220 | 82221 |
| 12 x 18 - 2 Ledge | 50lb | 82250 | 82251 |
| 18 x 18" | 65lb | 82222 | 82223 |
| 18 x 18 - 2 Ledge | 65lb | 82252 | 82253 |
| 18 x 24" | 75lb | 82224 | 82225 |
| 18 x 24 - 2 Ledge | 75lb | 82254 | 82255 |
| 24 x 24" | 85lb | 82226 | 82227 |
| 24 x 24 - 2 Ledge | 85lb | 82256 | 82257 |
| 24 x 36" | 95lb | 82228 | 82229 |
| 24 x 36 - 2 Ledge | 95lb | 82258 | 82259 |
| 24 x 48" | 145lb | 82230 | 82231 |
| 24 x 48 - 2 Ledge | 145lb | 82260 | 82261 |
| 30 x 48" | 155lb | 82266 | 82268 |
| 30 x 48 - 2 Ledge | 155lb | 82267 | 82269 |
| 36 x 36" | 165lb | 82232 | 82233 |
| 36 x 36 - 2 Ledge | 165lb | 82262 | 82263 |
| 36 x 48" | 185lb | 82234 | 82235 |
| 36 x 48 - 2 Ledge | 185lb | 82264 | 82265 |
| 36 x 60" | 205lb | 82236 | 82237 |
| 36 x 72" | 235lb | 82238 | 82239 |
| 48 x 48" | 210lb | 82270 | 82272 |
| 48 x 60" | 250lb | 82240 | 82241 |
| 48 x 72" | 265lb | 82242 | 82243 |
| 48 x 96" | 345lb | 82244 | 82245 |



Cabinet Type Surface Plate Stand

CABINET TYPE SURFACE PLATE STANDS

Cabinet stands provide a strong, rigid support for standard plates listed, plus a handy place to store frequently used inspection tools and accessories.

The standard height is 34-36" (900mm) from the floor to top of the surface plate.

All stands are made from heavy-gage welded steel and have locking doors on the front. The 48" (1200mm) wide stands are equipped with doors front and back unless otherwise specified. Stands are supplied with leveling screws or casters as listed. Order by surface plate size. (Works on all thicknesses, and plate with our without ledges.)

| Cabinet Type Surface Plate Stands | | | | | |
|-----------------------------------|-------------|--------------|-----|------------------|---------------|
| Surface Plate Size | | Stand Weight | | Stationary Stand | Rolling Stand |
| in | mm | lb | kg | EDP | EDP |
| 24 x 36 | 600 x 900 | 190 | 86 | 81504 | 81506 |
| 36 x 36 | 900 x 900 | 245 | 111 | 81516 | 81518 |
| 36 x 48 | 900 x 1200 | 300 | 136 | 81513 | 81515 |
| 36 x 60 | 900 x 1500 | 365 | 166 | 81519 | 81521 |
| 36 x 72 | 900 x 1800 | 440 | 200 | 81522 | 81524 |
| 48 x 72 | 1200 x 1800 | 660 | 299 | 81525 | 81527 |





Toolmakers' Flat

GRANITE ACCESSORIES

TOOLMAKERS' FLATS

These handy flats are small precision surface plates that are ideal for many inspection and checking uses throughout the plant.

They are especially well suited for layout work and offer an easy, portable reference for gaging small parts.

Offered in Crystal Pink® or Black Granite, Starrett Toolmakers' Flats are 12" long x 8" wide x 2" thick (300 x 200 x 50mm) and finished to an overall tolerance of .0001" (0.0025mm).

The shipping weight without case is 20 lb (9kg).

| Toolmakers' Flats | |
|-------------------|---|
| EDP | Description |
| 81803 | Crystal Pink® granite |
| 81802 | Black granite |
| 81804 | Sturdy felt lined case for toolmakers' flat |

THREE-FACE GRANITE TRI-SQUARES

Three-Face Granite Tri-Squares provide an excellent, economical way for accurately checking the X-Y-Z axes on CNC machine tools and coordinate measuring machines.

Laying in the horizontal position, the X and Y axes can be checked for 90° squareness. With the square in the vertical position, tracing along the vertical edge of the square can check the perpendicularity of the Z axis.

Granite tri-squares may also be used in the same manner that steel squares would be used for the direct checking of squareness and straightness.



Tri-Square

| Three-Face Granite Tri-Squares | | | | | |
|--|---|--|-----------------|--------|-----|
| Accuracy Grade – EDP | | Dimensions (Length x Height x Thickness) | | Weight | |
| AA Laboratory .000025"/6" TIR (0.0006/150mm) | A Inspection .000050"/6" TIR (0.0012/150mm) | in | mm | lb | kg |
| 81969 | 81970 | 6 x 9 x 3 | 150 x 225 x 75 | 18 | 8 |
| 81961 | 81962 | 9 x 12 x 3 | 225 x 300 x 75 | 23 | 10 |
| 81964 | 81965 | 12 x 18 x 4 | 300 x 450 x 100 | 60 | 27 |
| 81967 | 81968 | 18 x 24 x 4 | 450 x 600 x 100 | 120 | 54 |
| 81971 | 81972 | 24 x 36 x 6 | 600 x 900 x 150 | 570 | 259 |

Other sizes quoted on application.



GRANITE ACCESSORIES

FIVE-FACE MASTER SQUARES

Five-Face Granite Master Squares are popular for accurately checking the X-Y-Z axes on CNC machine tools and coordinate measuring machines.

Laying in the horizontal position, the X and Y axes can be checked for 90° squareness. With the square in the vertical position, tracing along the vertical edge of the square can check the perpendicularity of the Z axis. By tracing along the top edge of the square while in the vertical position, it will check parallelism of the table in the X and Y axes.

Five-face master squares may also be used on any work that requires the checking of squareness or parallelism.



Five-Face Master Square

| Accuracy Grade – EDP | | Dimensions (Length x Height x Thickness) | | Weight | |
|--|---|--|-----------------|--------|-----|
| AA Laboratory .000025"/6" TIR (0.0006/150mm) | A Inspection .000050"/6" TIR (0.0012/150mm) | in | mm | lb | kg |
| 81919 | 81920 | 12 x 12 x 3 | 300 x 300 x 75 | 41 | 19 |
| 81922 | 81923 | 14 x 14 x 3 | 350 x 350 x 75 | 56 | 25 |
| 81925 | 81926 | 16 x 16 x 4 | 400 x 400 x 100 | 98 | 44 |
| 81931 | 81932 | 24 x 24 x 4 | 600 x 600 x 100 | 220 | 100 |
| 81933 | 81934 | 36 x 36 x 6 | 900 x 900 x 150 | 855 | 388 |

24 x 24 and larger have a thru-hole for lifting with a sling.



Granite Parallels

GRANITE PARALLELS

Produced in four standard sizes, Granite Parallels are useful in setting up work on surface plates and machine tables. They can also be used to elevate work above the surface of a plate to enable quick and easy inspection of piece parts with shoulders or steps.

Available in matched pairs, finished flat and parallel on two opposite narrow faces or all four faces. Single parallels available by request. Storage cases are available at extra cost.

| Length x Width x Thickness | | Grade AA Laboratory | | Grade A Inspection | | Weight per Pair | | Case Only | | | | |
|----------------------------|-----------------|--------------------------------|------------|--------------------|--------------------------------|-----------------|------------|-----------|-------|----|-------|-------|
| in | mm | .000025"/6" TIR (0.0006/150mm) | 2-Face EDP | 4-Face EDP | .000050"/6" TIR (0.0012/150mm) | 2-Face EDP | 4-Face EDP | EDP | | | | |
| | | in | mm | | in | mm | lb | kg | | | | |
| 6 x .75 x 1 | 150 x 19 x 25 | .000025 | 0.0012 | 81691 | .000050 | 0.0025 | 81693 | 81694 | 1 | .5 | 81720 | |
| 12 x 1 x 2 | 300 x 25 x 50 | | | 81695 | | | 81696 | 81697 | 81698 | 5 | 2.3 | 81721 |
| 18 x 1.5 x 3 | 450 x 37.5 x 75 | | | 81699 | | | 81700 | 81701 | 81702 | 18 | 8 | 81722 |
| 24 x 2 x 4 | 600 x 50 x 100 | | | 81703 | | | 81704 | 81705 | 81706 | 42 | 19 | 81723 |



GRANITE ACCESSORIES

STRAIGHT EDGES

Our straight edges are produced from Master Pink granite, as are all of our accessories. Straight edges have a single long, narrow face finished flat. Lifting holes are provided on sizes 48" or larger.



Straight Edge

| Straight Edges | | | | | |
|---|--|----------------------------|-----------------|--------|-----|
| Grade A Inspection .000050"/6" TIR (0.0012/150mm) EDP | Grade AA Laboratory .000025"/6" TIR (0.0006/150mm) EDP | Length x Width x Thickness | | Weight | |
| | | in | mm | lb | kg |
| 81608 | 81648 | 2 x 4 x 24 | 50 x 100 x 600 | 22 | 10 |
| 81610 | 81650 | 2 x 6 x 36 | 50 x 150 x 900 | 48 | 22 |
| 81612 | 81652 | 3 x 8 x 48 | 75 x 200 x 1200 | 85 | 39 |
| 81613 | 81653 | 3 x 10 x 60 | 75 x 250 x 1500 | 198 | 90 |
| 81614 | 81654 | 3 x 12 x 72 | 75 x 300 x 1800 | 285 | 129 |

FIVE-FACE V-BLOCKS

V-Blocks are ideal for supporting or holding cylindrical pieces during manufacturing or inspection. They are provided in matched pairs and have 5 finished faces. V-blocks have a nominal 90-degree "V", centered with and parallel to the bottom and two sides and square to the ends.



Five-Face V-Block

| Five-Face V-Blocks | | | | | |
|--|---|----------------------------|-----------------|--------|-----|
| Grade AA Laboratory .000050"/6" TIR (0.0012/150mm) EDP | Grade A Inspection .000100"/6" TIR (0.0024/150mm) EDP | Length x Width x Thickness | | Weight | |
| | | in | mm | lb | kg |
| 81533 | 81530 | 3 x 3 x 3 | 75 x 75 x 75 | 6 | 3 |
| 81534 | 81531 | 4 x 4 x 4 | 100 x 100 x 100 | 15 | 7 |
| 81535 | 81532 | 6 x 6 x 6 | 150 x 150 x 150 | 48 | 22 |
| 81537 | 81536 | 9 x 9 x 9 | 225 x 225 x 225 | 160 | 73 |
| 81539 | 81538 | 12 x 12 x 12 | 300 x 300 x 300 | 380 | 172 |

SIX-FACE CUBES

The granite cube has all six faces finished flat, perpendicular and parallel.



Six-Face Cube

| Six-Face Cubes | | | | | |
|--|---|----------------------------|-----------------|--------|----|
| Grade AA Laboratory .000050"/6" TIR (0.0012/150mm) EDP | Grade A Inspection .000025"/6" TIR (0.0006/150mm) EDP | Length x Width x Thickness | | Weight | |
| | | in | mm | lb | kg |
| 81980 | 81981 | 3 x 3 x 3 | 75 x 75 x 75 | 3 | 1 |
| 81982 | 81983 | 4 x 4 x 4 | 100 x 100 x 100 | 8 | 4 |
| 81984 | 81985 | 6 x 6 x 6 | 150 x 150 x 150 | 24 | 11 |



GRANITE ACCESSORIES

NEW!

GRANITE SURFACE PRODUCTS

ANGLE PLATES

Angle plates provide a convenient and practical means of clamping and holding work in a vertical position. Their excellent finish and flatness make them very compatible for use with granite surface plate accuracies. The angle plates are available with either 2 or 4 finished faces. The 2-face angle plate has the bottom and the adjacent square face finished flat and square to one another. The 4-face is similar to the 2-face, but has the two adjacent sides finished flat and square to the other two faces, as well as being parallel to each other.



Angle Plate

FOUR-FACE INSERTED ANGLE PLATES

Inserted angle plates are available upon request. This product is the same as our standard angle plate, with the addition of metal discs inserted into one side. The inserted angle plates also have a main gauging face for magnetic chucking purposes and threaded inserts for clamping purposes.

| Angle Plates | | | | Four-Face Inserted Angle Plates | | | | | | | |
|---|-----------------|---|---------------|--|---------------|---|-------|--|-------|--------|----|
| Size (Length x Width x Thickness) in mm | | Grade AA Laboratory .000025"/6" TIR (0.0006/150mm) | | Grade A Inspection .000050"/6" TIR (0.0012/150mm) | | Grade AA Laboratory .000025"/6" TIR (0.0006/150mm) | | Grade A Inspection .000050"/6" TIR (0.0012/150mm) | | Weight | |
| | | 2-Face EDP | 4-Face EDP | 2-Face EDP | 4-Face EDP | EDP | EDP | EDP | EDP | lb | kg |
| 4 x 4 x 4 | 100 x 100 x 100 | 81564 | 81565 | 81562 | 81563 | 81860 | 81861 | 81860 | 81861 | 8 | 4 |
| 6 x 6 x 6 | 150 x 150 x 150 | 81569 | 81568 | 81566 | 81567 | 81864 | 81865 | 81864 | 81865 | 24 | 11 |
| 6 x 9 x 12 | 150 x 225 x 300 | 81572 | 81573 | 81570 | 81571 | 81868 | 81869 | 81868 | 81869 | 72 | 33 |
| 9 x 9 x 9 | 225 x 225 x 225 | 81576 | 81577 | 81574 | 81575 | | | | | 80 | 36 |
| 12 x 12 x 12 | 300 x 300 x 300 | 81579 | 81578 | 81581 | 81580 | | | | | 190 | 86 |

SURFACE PLATE COVERS

We highly recommend the use of surface plate covers to protect your precision granite investment. Prevent abrasive build up on your plates with our covers made from heavy gage vinyl with a soft interior lining. Our covers provide a tough, durable, protective outside with a soft cushion inside.



| Vinyl Covers | | |
|--------------|------------------------------|-------------|
| EDP | For Surface Plate Size in | mm |
| 83020 | 12 x 12 | 300 x 300 |
| 83021 | 12 x 18 | 300 x 450 |
| 83022 | 18 x 18 | 450 x 450 |
| 83023 | 18 x 24 | 450 x 600 |
| 83024 | 24 x 24 | 600 x 600 |
| 83025 | 24 x 36 | 600 x 900 |
| 83026 | 24 x 48 | 600 x 1200 |
| 83034 | 30 x 48 | 750 x 1200 |
| 83027 | 36 x 36 | 900 x 900 |
| 83028 | 36 x 48 | 900 x 1200 |
| 83029 | 36 x 60 | 900 x 1500 |
| 83030 | 36 x 72 | 900 x 1800 |
| 83035 | 48 x 48 | 1200 x 1200 |
| 83031 | 48 x 60 | 1200 x 1500 |
| 83032 | 48 x 72 | 1200 x 1800 |
| 83033 | 48 x 96 | 1200 x 2400 |

SURFACE PLATE CLEANER

To keep surface plates and other precision granite products in top condition, they should be cleaned frequently with Starrett Cleaner. This helps prevent abrasion of tools by dirt and other foreign particles.

The liquid cleaner, which also acts as a degreaser and rust inhibitor, should be used without water to minimize the risk of rusting tools.



Surface Plate Cleaner (left to right) - 1 gal., 1 qt., 1lb, wipes

| Surface Plate Cleaner | |
|-----------------------|---|
| EDP | Description |
| 81820 | 55 gal. (208 liter) Drum |
| 81822 | 1 gal. (3.8 liter), Case of four |
| 81824 | 1 quart (1 liter), Case of 12 |
| 81828 | Waterless Cleaner, Case of 12 1lb jars |
| 81829 | Waterless Cleaner Wipes, Case of 4 1.5lbs canisters |



SURFACE PLATE CALIBRATION PRODUCTS

PLANEKATOR KITS

The Planekator measures the overall flatness of your surface plate. It enables you to take direct indicator readings of your surface plate with autocollimator-accuracy, but without the complicated mathematics of the autocollimator. When used in conjunction with a Starrett Repeat Reading Gage, you'll have a very accurate idea of the flatness of your surface plate.

Each kit includes a precision granite straight edge, one adjustable support, one fixed support, a certified 0.00002" dial indicator and an indicator carriage. The entire kit is shipped in a heavy-duty travel case. The straight edge comes equipped with lifting handles, correction tape indicating the accuracy at 1" intervals, and includes a NIST-traceable certificate that meets ISO/IEC 17025 requirements.

The Planekator straight edge should be at least equal to the full width, and at least equal to 50% of the length of the largest surface you will be inspecting. For example, a 36" planekator straight edge can be used to calibrate any surface up to 36" x 72".

| Part No. | Size (in) | Total Weight of Kit (lbs) | Straight Edge Accuracy (in) |
|----------|-----------|---------------------------|-----------------------------|
| 80500 | 24 | 50 | 0.000050 |
| 80501 | 36 | 80 | 0.000075 |
| 80502 | 48 | 115 | 0.000100 |



Planekator

REPEAT READING GAGE

High-precision, fast checking of surface plate repeatability with readings taken with a dial indicator. Detects local error, not overall flatness. The base has an adjustment knob for zero-setting the cartridge-type gaging head, and all contact points resting on the granite, including the contact point of the gaging cartridge, are carbide and lapped to a fine finish.

The instrument also accommodates AGD indicators with .375" (9.5mm) diameter stems.

| Repeat Reading Gage | |
|---------------------|-------------------------|
| EDP | Description |
| 81320 | Repeat Reading Gage |
| 81321 | Storage Case |
| 81322 | Travel Case |
| 81850 | 0.00002" Dial Indicator |



Repeat Reading Gage

GRANITE CALIBRATION SERVICES

Starrett calibration and resurfacing services are available for all types and brands of granite surface plates. When certification of surface tolerance is required, recalibration service with an autocollimator will be provided with accuracy traceable to the U.S. National Institute of Standards and Technology.

Calibration and resurfacing of surface plates, tri-squares, master squares, master angles, V-blocks, parallels and straight edges is available at our at Waite Park, MN location.

Resurfacing can also be done in your plant, saving crating and shipping costs as well as equipment down time. The cost is based on a square foot plate area with additional charge for travel. For a quotation, send us a list of plates, their sizes and the flatness tolerance required.

When resurfacing is done in your plant, tolerances for repeat reading of measurement will be per U.S. Federal Specification GGG-P-463c, and ASME B89.3.7-2013. Closer repeat reading tolerances of 25, 50 and 100 millionths can only be assured if the resurfacing is done at our facilities.

Recalibrations are provided by our Calibration Lab which is A2LA accredited.

| Tolerances for Repeat Reading of Measurement | | | | |
|--|---|-----------|-----------|--------------------|
| Diagonal Inches (mm) | Full Indicator Movement (F.I.M.) in Microinches and (Microns) | | | Obtained |
| | Grade AA | Grade A | Grade B | |
| Through 30" (750) | 35 (.9) | 60 (1.5) | 110 (2.8) | When not Specified |
| 30-60" (750-1500) | 45 (1.1) | 70 (1.8) | 120 (3) | |
| 60-90" (1500-2250) | 60 (1.5) | 80 (2) | 160 (4) | |
| 90-120" (2250-3000) | 75 (1.9) | 100 (2.5) | 200 (5) | |
| 120-150" (3000-3800) | 90 (2.3) | 120 (3) | 240 (6) | |
| Over 150" (3800) | 100 (2.5) | 140 (3.6) | 280 (7) | |
| All Sizes | 25 (.6) | 50 (1.3) | 100 (2.5) | |

A repeat reading gage detects minute variations of the surface within the unilateral flatness tolerance of the whole surface.



Starrett



Our broad range of metrology systems are ideal for use in QC labs, research, engineering, and manufacturing environments where small to large scale high-precision measurement is critical.

Many systems are available in either manual or CNC configurations.

VISION SYSTEMS

MANUAL VISION METROLOGY SYSTEMS

MV

MV300

MV Video Based Metrology Systems are easy-to-use, general purpose, non-contact measurement systems with zoom optics. A highly stable mechanical design and precision linear bearings achieve superb performance. X and Y dimensions are measured by moving the stage horizontally. Z height is measured by moving vertically to maintain focus. MV systems are ideal for Quality Labs, and manufacturing floor part measurement where short runs are common.

The operator interface is a MetLogix™ M3-equipped PC, while the part image, measurement graphics, and readings are displayed on a color touch-screen monitor. Single and multi-point measurements of 2D geometries, and report generation are standard.

MV OPTICS

| Optical Parameters | 6.5:1 Zoom Optics Dedicated |
|--------------------------------|--------------------------------|
| Optical magnification on CCD | 0.47x to 3.0x |
| Total magnification on monitor | 31x to 200x |
| Field of view | .39" to .06" (10 to 1.6mm) |
| Working distance | 3.47" (88mm) |
| Camera CCD | 1/3" CCD Array |

OPERATOR INTERFACE

| Feature | Touch-Screen Monitor and M3 DXF/FOV Software |
|---|---|
| 24" (60cm) color graphic monitor and PC | x |
| Windows®-based operating system | x |
| Wi-Fi network connectivity | x |
| Video edge detection | x |
| X-Y-Z measurements | x |
| 2D geometric constructs plus height | x |
| FOV measurements integrated with X-Y stage motion | x |
| CAD file import and export | x |
| Automatic comparison of measurements to CAD files | x |
| Software developer | MetLogix™ |





FEATURES AND SPECIFICATIONS

- Zoom optics 6.5:1
- MetLogix™ M3 measuring software
- Video edge detection (VED)
- Fiber Optic or LED illumination, sub-stage bottom illumination and ring light surface illumination
- Easy manual X-Y-Z positioning via hand wheels

OPTIONS

- 0.5x, 1.5x, and 2.0x auxiliary lenses for zoom optics
- Coaxial LED or fiber optic surface illumination
- Calibration standards
- DXF/FOV option for automatic comparison to CAD files
- Modular system workstation

MV300 DIMENSIONS

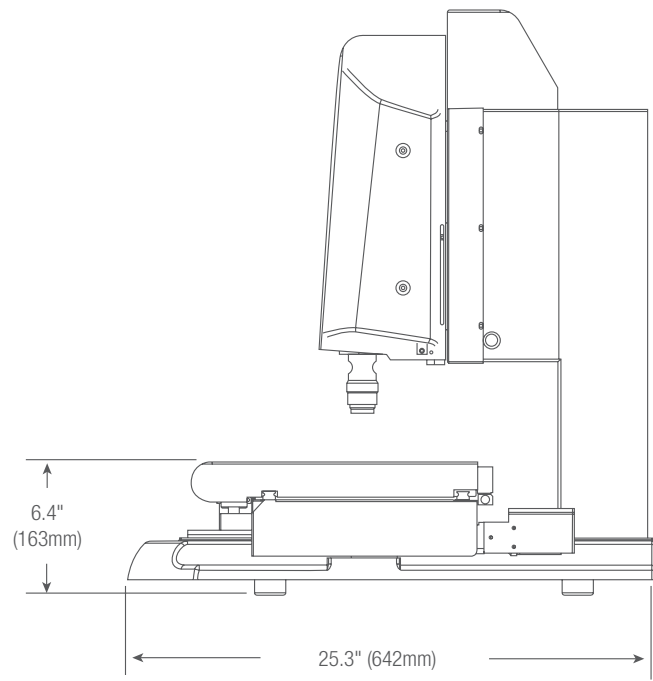
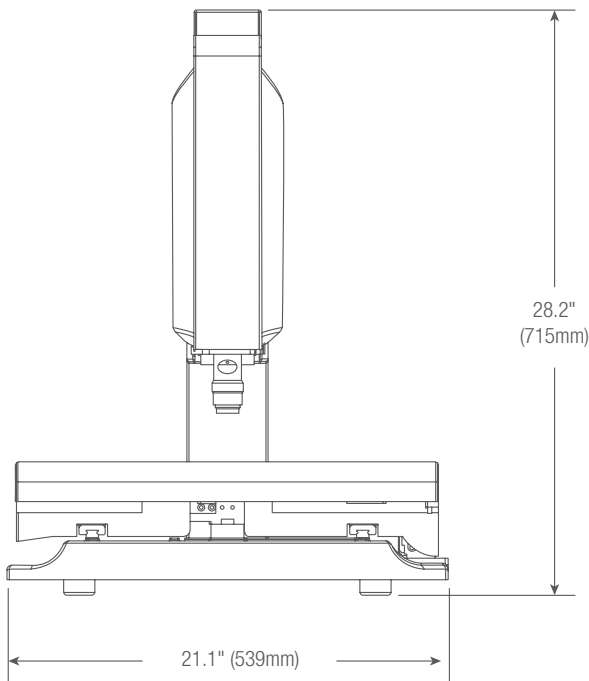

SPECIFICATIONS

| | MV300 |
|-----------------|------------------------------------|
| Net Weight | 115lbs 53kg |
| Shipping Weight | 345lbs 157kg |
| X-Y-Z Travel | 12 x 6 x 5.5" 300 x 150 x 135mm |
| X-Y Accuracy | 3.5µm + 5L/1000 |
| Z Accuracy | 2.5µm + 5L/1000 |



MANUAL VISION METROLOGY SYSTEMS

MVR

MVR200 AND MVR300

The MVR Manual Vision Metrology Systems are ideal for individual measurements or short runs. They are available with dedicated zoom optics or a quick-change bayonet lens mount which accepts interchangeable zoom optics or telecentric lenses for micron-level resolution and accurate field-of-view (FOV) measurements. These can encompass an entire small part up to 2.00 x 1.50" or a feature of a larger part and be seamlessly integrated with stage motion to measure parts with a length up to 8" (MVR200) or 12" (MVR300). The operator interface is the MetLogix™ M3 FOV software that displays a live video image of the part plus geometry tools and digital readings. The image of the part can be resized using zoom, and measurements can be taken by simply touching a feature on the touch-screen.

MVR hardware features include a granite base for maximum stability, precision recirculating ball linear guides for smooth, accurate stage motion and a motorized Z-axis with variable speed control.

MVR OPTICS

| Optical Parameters | Interchangeable Telecentric Optics | | | | | | 6.5:1 Zoom Optics | |
|--------------------------------|------------------------------------|--------------|--------------|--------------|--------------|--------------|----------------------------|----------------------------|
| | | | | | | | Interchangeable | Dedicated |
| Optical magnification on CCD | 0.30x | 0.50x | 0.80x | 1.0x | 2.0x | 4.0x | 0.7x to 4.5x | 0.47x to 3.0x |
| Total magnification on monitor | 13x | 22x | 36x | 45x | 89x | 178x | 31x to 200x | 31x to 200x |
| Field of view | .94" (24mm) | .55" (14mm) | .35" (9mm) | .27" (7mm) | .14" (3.5mm) | 1.8" (1.8mm) | .39" to .06" (10 to 1.6mm) | .39" to .06" (10 to 1.6mm) |
| Working distance | 4.3" (110mm) | 4.3" (110mm) | 4.3" (110mm) | 4.3" (110mm) | 4.3" (110mm) | 4.3" (110mm) | 3.47" (88mm) | 3.47" (88mm) |
| Camera CCD | 1/1.8" | 1/1.8" | 1/1.8" | 1/1.8" | 1/1.8" | 1/1.8" | 1/1.8" CCD Array | 1/3" CCD Array |

OPERATOR INTERFACE

| Feature | M3 DXF/FOV Software |
|---|---------------------|
| M3 controller housed in Z column | x |
| Wi-Fi network connectivity | x |
| Video edge detection | x |
| X-Y-Z measurements | x |
| 2D geometric constructs plus height | x |
| FOV measurements integrated with X-Y stage motion | x |
| CAD file import and export | x |
| Automatic comparison of measurements to CAD files | x |
| Software developer | MetLogix™ |



MVR200



FEATURES AND SPECIFICATIONS

- Z travel: 8" (200 mm) with 2.0x auxiliary lens
- Manual X-Y positioning via hand wheels
- Motorized Z-axis positioning with variable speed control
- MetLogix™ M3 metrology software
- Video edge detection (VED)
- Field-of-view (FOV) measurements integrated with stage motion
- Renishaw scales for .00002" (0.5µm) of X and Y resolution
- Color digital video camera
- Collimated LED sub-stage illumination
- Ring light LED surface illumination
- Granite base

OPTIONS

- Optional dedicated or interchangeable 6.5:1 zoom lens
- Quick-change bayonet lens mount for interchangeable zoom or telecentric optics
- Auxiliary Lenses for Zoom Optics: 0.5x, 1.5x and 2.0x
- Interchangeable telecentric lens magnifications including - .3x, .5x, .8x, 1.0x, 2.0x and 4.0x
- DXF/FOV option for automatic comparison to CAD files
- Modular system workstation
- Calibration standards

MVR DIMENSIONS

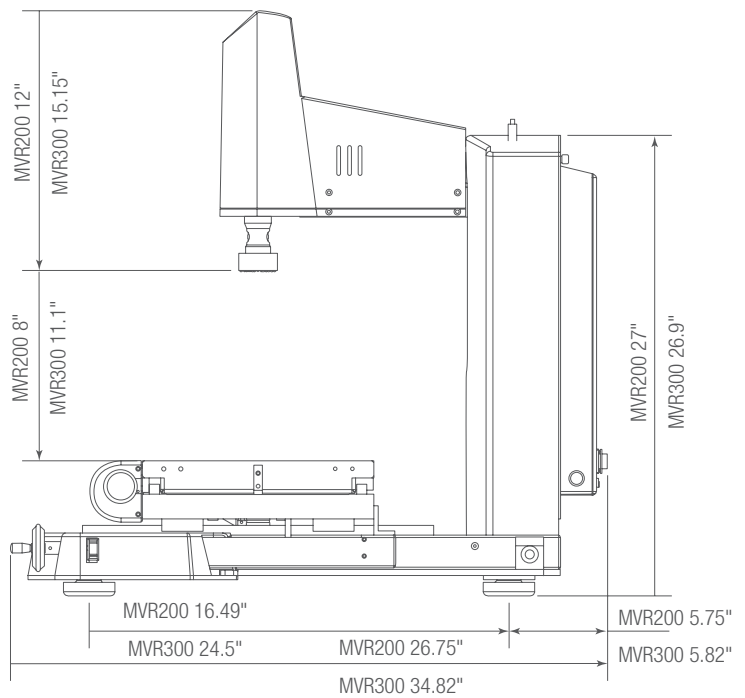
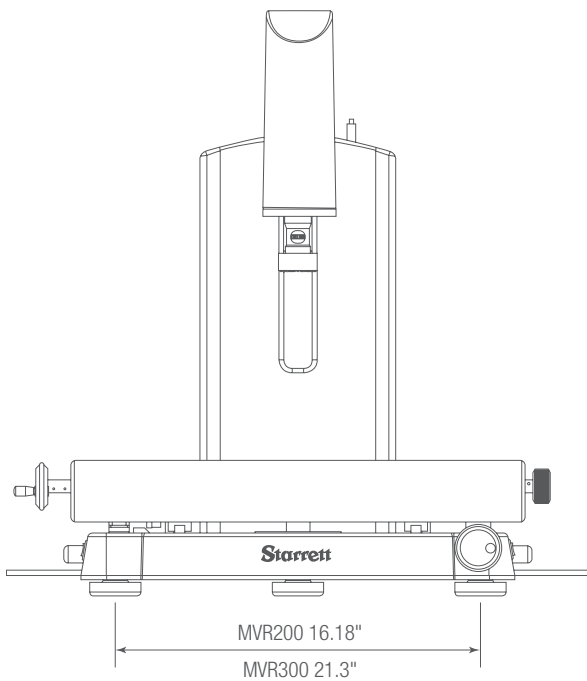

SPECIFICATIONS

| | MVR200 | MVR300 |
|-----------------|-----------------|-----------------|
| Net Weight | 145lbs | 230lbs |
| | 90kg | 113kg |
| Shipping Weight | 250lbs | 300lbs |
| | 115kg | 135kg |
| X-Y Travel | 8 x 4" | 12 x 8" |
| | 200 x 100mm | 300 x 200mm |
| X-Y-Z Accuracy | 2.5µm + 5L/1000 | 2.5µm + 5L/1000 |



AUTOMATIC VISION METROLOGY SYSTEMS



AV300 AND AV350

The AV Automatic Vision Metrology Systems provide accurate 3-axis measurement capability (X-Y-Z) with hi-resolution video zoom optics and optional touch probe. The systems can be pre-programmed (CNC) for repetitive part inspection, or driven manually via a joystick and trackball for individual measurements. Superb performance is achieved by a highly stable mechanical design, with precision linear bearings. Throughput is maximized with either QC5000 or MetLogix™ M3 software controlling all features of Video Edge Detection (VED) and multiple channel Fiber Optic or LED illumination.

These automatic vision systems are ideal for quality assurance, inspection, and production runs. Flexible and powerful, the AV series allows users to cost effectively achieve maximum throughput of their inspection process. Measured data is effectively archived or networked to other devices.

AV OPTICS

| Optical Parameters | Dedicated Zoom Optics | |
|--------------------------------|----------------------------|-----------------------------|
| | 6.5:1 | 12:1 |
| Optical magnification on CCD | 0.47x to 3.0x | 1.4x to 4.7x |
| Total magnification on monitor | 31x to 198x | 26x to 310x |
| Field of view width | .39" to .06" (10 to 1.6mm) | .44" to .047" (11 to 1.2mm) |
| Working distance | 3.47" (88mm) | 3.38" (86mm) |
| Camera CCD | 1/3" | 1/3" |

OPERATOR INTERFACE

| Feature | MetLogix™ M3 | QC5000 |
|--|--------------|----------------------|
| 24" (60cm) touch-screen monitor and PC | x | |
| External motion control unit | x | x |
| Windows®-based operating system | x | x |
| Wi-Fi network connectivity | x | x |
| CAD file import and export | x | x |
| Video edge detection | x | x |
| X-Y-Z measurements | x | x |
| 2D geometric constructs | x | x |
| 3D geometric constructs | | x |
| CNC control capability | x | x |
| Report generation and archiving | x | x |
| Optional DXF/FOV software | x | |
| Software developer | MetLogix™ | Metronics/Heidenhain |

AV350 shown with system stand and control cart - included



FEATURES AND SPECIFICATIONS

- CNC operation or manual operation via joystick and trackball
- Reading resolution 4µin (0.1µm)
- MetLogix™ M3 metrology software
- Magnification on 24" monitor, 1:1 pixel setting: 37x to 240x with 6.5:1 zoom, 25x to 240x with 12:1 zoom
- Multiple channel Fiber Optic or LED Illumination
- Cast aluminum base for AV300. Granite base on AV350
- 1.3 mega-pixel color digital video camera

OPTIONS

- 6.5:1 or 12:1 dedicated zoom optics
- Optional 0.5x, 1.5x and 2.0x auxiliary lenses
- Renishaw touch probe kit
- Ergonomic workstation (machine stand and control cart standard (with AV350))
- LED dark-field quadrant illuminator
- DXF/FOV option for automatic comparison to CAD files
- Calibration standards
- Part fixtures and work-holding devices

AV300 DIMENSIONS

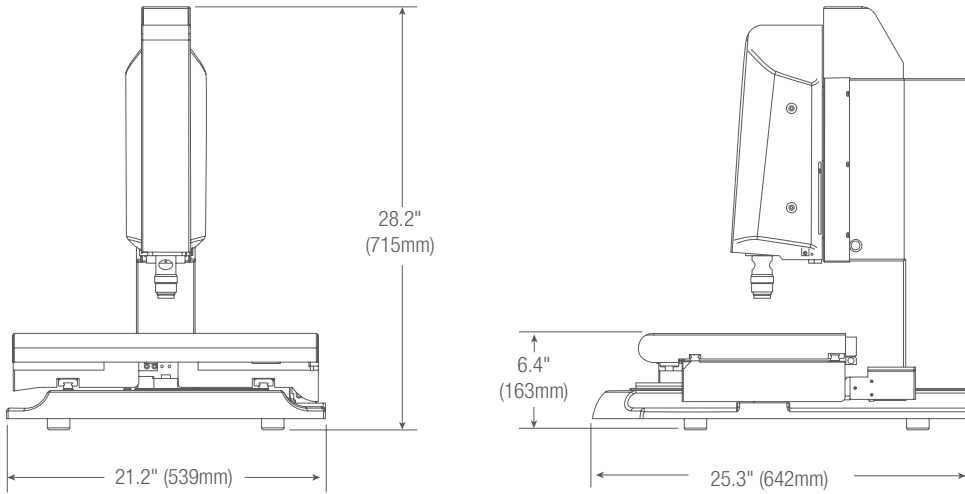

AV350 DIMENSIONS

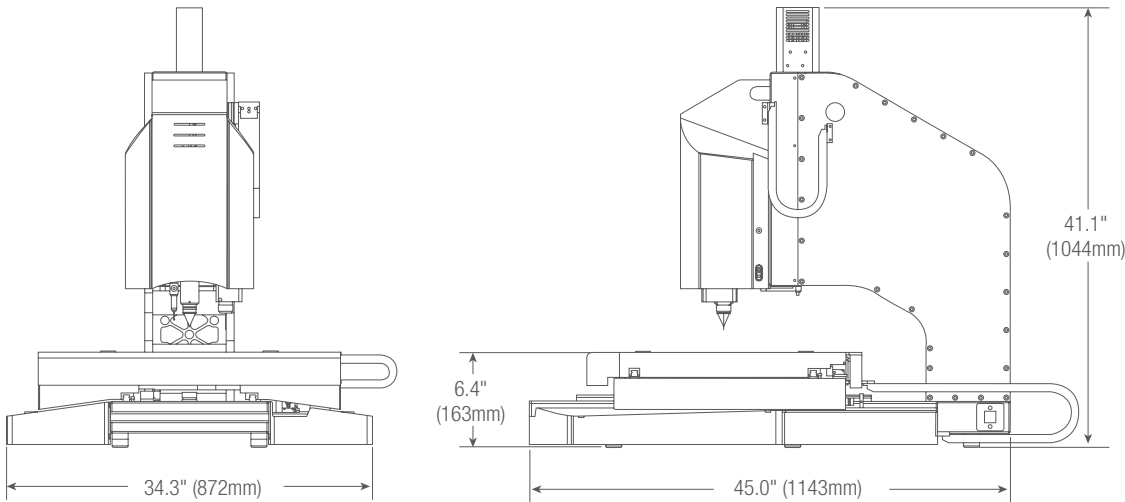

SPECIFICATIONS

| | AV300 | AV350 |
|-------------------|------------------------------------|-----------------------------------|
| Net Weight | 125lbs 57kg | 409lbs 185kg |
| Shipping Weight | 345lbs 157kg | 1,275lbs 579kg |
| X-Y-Z Travel | 12 x 6 x 5.5" 300 x 150 x 140mm | 14 x 14 x 8" 350 x 350 x 200mm |
| X-Y Accuracy (µm) | E2 = 1.9µm + 5L/1000 | E2 = 2.5µm + 5L/1000 |
| Z Accuracy (µm) | E1 = 2.5µm + 5L/1000 | E1 = 2.5µm + 5L/1000 |



AUTOMATIC VISION METROLOGY SYSTEMS

AVR

AVR200 AND AVR300

The AVR CNC Automatic Vision Metrology Systems are ideal for repetitive measurements and automatic comparison to CAD files. Available with dedicated interchangeable telecentric lenses for micron-level resolution and accurate field-of-view (FOV) measurements. These can encompass an entire small part up to 2.00 x 1.50" or a feature of a larger part and be seamlessly integrated with stage motion to measure parts with a length up to 8" (AVR200) or 12" (AVR300). MetLogix™ M3 software capabilities include 3-axis measurements and 2D geometric constructs (points, lines, angles, rectangles). Systems are also touch probe compatible.

AVR OPTICS

| Optical Parameters | Telecentric Optics | | | | | | Dedicated Zoom Optics | |
|--------------------------------|--------------------|--------------|--------------|--------------|--------------|--------------|----------------------------|-----------------------------|
| | 0.30x | 0.50x | 0.80x | 1.0x | 2.0x | 4.0x | 6.5:1* | 12:1 |
| Optical magnification on CCD | 0.30x | 0.50x | 0.80x | 1.0x | 2.0x | 4.0x | 0.47x to 3.0x | 1.4x to 4.7x |
| Total magnification on monitor | 13x | 22x | 36x | 45x | 89x | 178x | 31x to 198x | 26x to 310x |
| Field of view width | .94" (24mm) | .55" (14mm) | .35" (9mm) | .27" (7mm) | .14" (3.5mm) | .07" (1.8mm) | .39" to .06" (10 to 1.6mm) | .44" to .047" (11 to 1.2mm) |
| Working distance | 4.3" (110mm) | 4.3" (110mm) | 4.3" (110mm) | 4.3" (110mm) | 4.3" (110mm) | 4.3" (110mm) | 3.47" (88mm) | 3.47" (86mm) |
| Camera CCD | 1/1.8" | 1/1.8" | 1/1.8" | 1/1.8" | 1/1.8" | 1/1.8" | 1/3" | 1/3" |

* 6.5:1 available as interchangeable zoom optics

OPERATOR INTERFACE

| Feature | All-in-One PC with M3 DXF/FOV Software |
|--|--|
| M3 controller housed in Z column | x |
| 24" (60cm) color graphic touch-screen monitor and PC | x |
| Windows®-based operating system | x |
| Wi-Fi network connectivity | x |
| Video edge detection | x |
| X-Y-Z measurements | x |
| 2D geometric constructs plus height | x |
| FOV measurements integrated with X-Y stage motion | x |
| CAD file import and export | x |
| Automatic comparison of measurements to CAD files | x |
| Software developer | MetLogix™ |





FEATURES

- Z travel: 8" (200 mm) with 2.0x auxiliary lens
- Full CNC X-Y-Z positioning or motorized manual positioning using a pendant with joystick and trackball
- Video edge detection (VED)
- Field-of-view (FOV) measurements integrated with stage motion
- Renishaw scales for .00002" (0.1µm) of X,Y and Z axis
- Color digital video camera
- Collimated LED sub-stage illumination
- Ring Light LED surface illumination
- Granite base

OPTIONS

- Dedicated 6.5:1 or 12:1 CNC zoom optics
- Quick-change bayonet lens mount for telecentric optics
- Interchangeable bayonet mount lenses - 0.30x, 0.50x, 0.80x, 1.0x, 2.0x, 4.0x telecentric optics and 6.5-1 manual zoom lens
- 0.5x, 1.5x and 2.0x auxiliary lenses for zoom optics
- Renishaw touch probe kit
- Quadrant LED surface illumination for zoom optics
- DXF/FOV option for automatic comparison to CAD files
- Modular system workstation
- Calibration standards
- Part fixtures and work holding devices

AVR DIMENSIONS

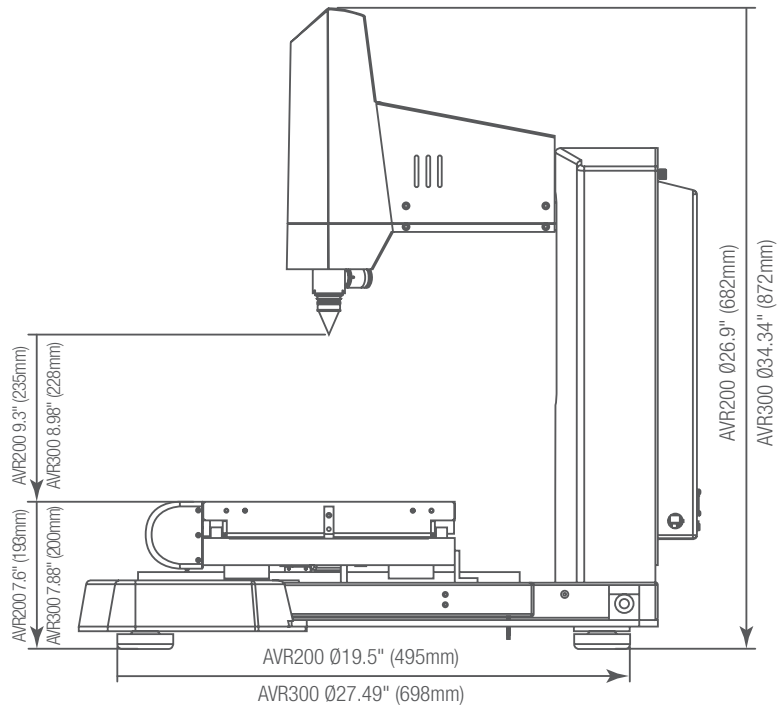
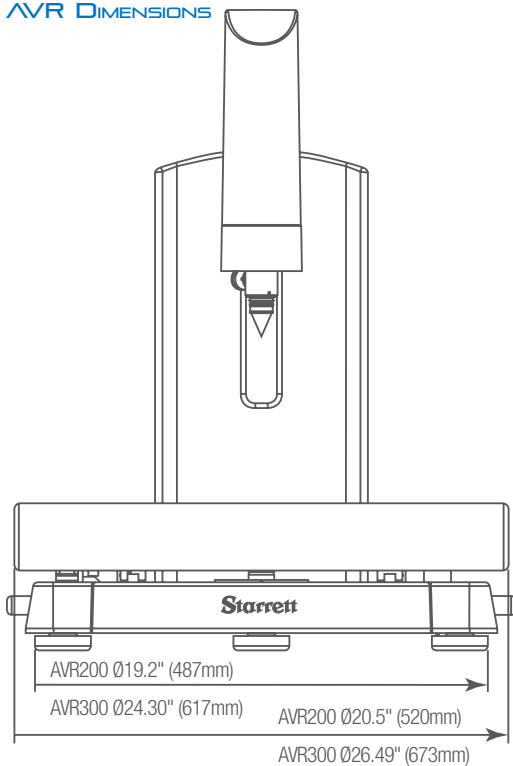

SPECIFICATIONS

| | AVR200 | AVR300 |
|------------------------|--------------------------------------|--------------------------------------|
| Net Weight | 145lbs 66kg | 225lbs 102kg |
| Shipping Weight | 250lbs 115kg | 300lbs 135kg |
| Dimensions (H x W x D) | 34 x 20.5 x 27" 863 x 520 x 685mm | 34 x 29.2 x 35" 865 x 740 x 890mm |
| X-Y-Z Travel | 8 x 4 x 8" 200 x 100 x 200mm | 12 x 8 x 8" 300 x 200 x 200mm |
| X-Y Accuracy | 1.9µm + 5L/1000 | 1.9µm + 5L/1000 |
| Z Accuracy | 2.5µm + 5L/1000 | 2.5µm + 5L/1000 |



AUTOMATIC VISION METROLOGY SYSTEMS

AV300+

MULTI-SENSOR

An enhanced version of the popular AV300 CNC video-based measurement system. The AV300+ system improves measuring performance by utilizing a precision granite base along with an extended travel Z column, delivering 12 x 6 x 8" (300 x 150 x 200mm) X-Y-Z measuring range. The system is a servo driven motion platform for enhanced performance and includes a 12:1 zoom lens, hi-resolution digital color camera and a choice of fiber optic or LED illumination. Complete with vibration isolation and integrated machine stand, the AV300+ delivers more capability for multi-sensor requirements. The AV300+ is powered by QC5300 software to handle a variety of measuring applications. Systems are available with vision, touch probe, laser sensors and rotary fixtures.

AV+ OPTICS

| Optical Parameters | Dedicated Zoom Optics |
|--------------------------------|-----------------------------|
| Optical magnification on CCD | 12:1 |
| Total magnification on monitor | 1.4x to 4.7x |
| Field of view width | 26x to 310x |
| Working distance | .44" to 0.47" (11 to 1.2mm) |
| Camera CCD | 3.47" (86mm) |
| | 1/3" |

OPERATOR INTERFACE

| Feature | QC5300 |
|--|----------------------|
| 24" (60cm) color graphic touch-screen monitor and PC | x |
| External motion control unit | x |
| Windows®-based operating system | x |
| Wi-Fi network connectivity | x |
| CAD file import and export | x |
| Video edge detection | x |
| X-Y-Z measurements | x |
| 2D geometric constructs | x |
| 3D geometric constructs | x |
| CNC control capability | x |
| Report generation and archiving | x |
| Software developer | Metronics/Heidenhain |



AV300+ shown with system stand and control cart - included



FEATURES AND SPECIFICATIONS

- 12:1 Zoom Optics with co-axial illumination
- Precision Granite base construction
- System stand and control cart standard
- Touch probe compatible
- Touch probe change rack compatible
- CNC Rotary Axis compatible
- Laser Probe compatible

OPTIONS

- 0.5x, 1.5x and 2.0x auxiliary lenses for zoom optics
- Quadrant LED dark-field surface illumination
- Renishaw touch probe kit
- 2 or 4 bay touch probe change rack compatible
- Optimet laser probe
- CNC rotary axis fixture
- Calibration standards
- Part fixtures and work-holding device

AV300+ DIMENSIONS

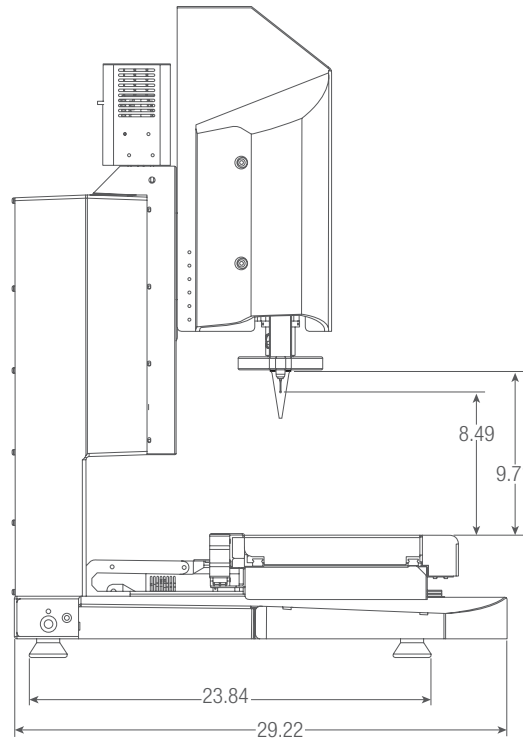
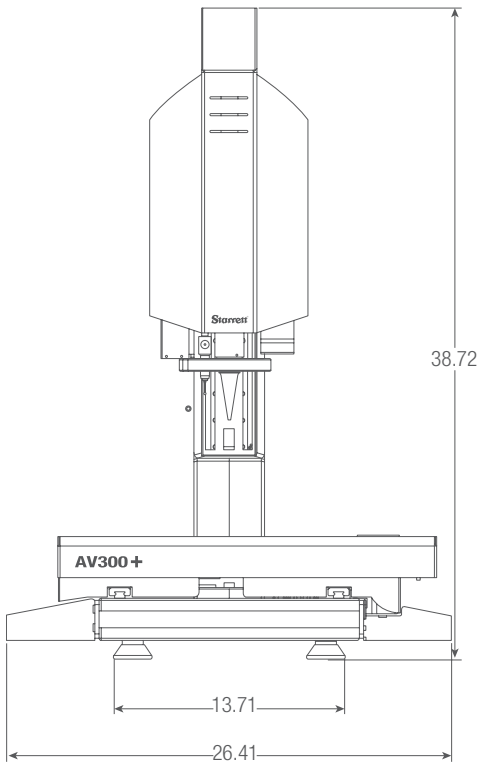

SPECIFICATIONS

| | AV300+ |
|-----------------|--------------------|
| Net Weight | 210lbs 95kg |
| Shipping Weight | 345lbs 157kg |
| X-Y Accuracy | E2 = 1.9 + 5L/1000 |
| Z Accuracy | E1 = 2.5 + 5L/1000 |



AUTOMATIC VISION METROLOGY SYSTEMS

AV350+

MULTI-SENSOR

Offering similar attributes and performance to the AV300+ with an expanded measurement envelope of 14 x 14 x 8" (350 x 350 x 200mm) X-Y-Z measuring range for those larger part and payload measurement requirements. Systems are available with vision, touch probe, laser sensors and rotary fixtures.

AV+ OPTICS

| Optical Parameters | Dedicated Zoom Optics 12:1 |
|--------------------------------|-------------------------------|
| Optical magnification on CCD | 1.4x to 4.7x |
| Total magnification on monitor | 26x to 310x |
| Field of view width | .44 to .047" (11 to 1.2mm) |
| Working distance | 3.47" (86mm) |
| Camera CCD | 1/3" |

OPERATOR INTERFACE

| Feature | QC5300 |
|---------------------------------|----------------------|
| Desktop PC with monitor | x |
| External motion control unit | x |
| Windows®-based operating system | x |
| Wi-Fi network connectivity | x |
| CAD file import and export | x |
| Video edge detection | x |
| X-Y-Z measurements | x |
| 2D geometric constructs | x |
| 3D geometric constructs | x |
| CNC control capability | x |
| Report generation and archiving | x |
| Software developer | Metronics/Heidenhain |





FEATURES AND SPECIFICATIONS

- 12:1 Zoom Optics with co-axial illumination
- Precision Granite base construction
- System stand and control cart standard

OPTIONS

- 0.5x, 1.5x and 2.0x auxiliary lenses for zoom optics
- Quadrant LED surface illumination for zoom optics
- Renishaw touch probe kit
- Optimet laser probe
- 2 or 4 touch probe change rack compatible
- CNC rotary axis fixture
- Calibration standards
- Part fixtures and work holding devices

AV350+ DIMENSIONS

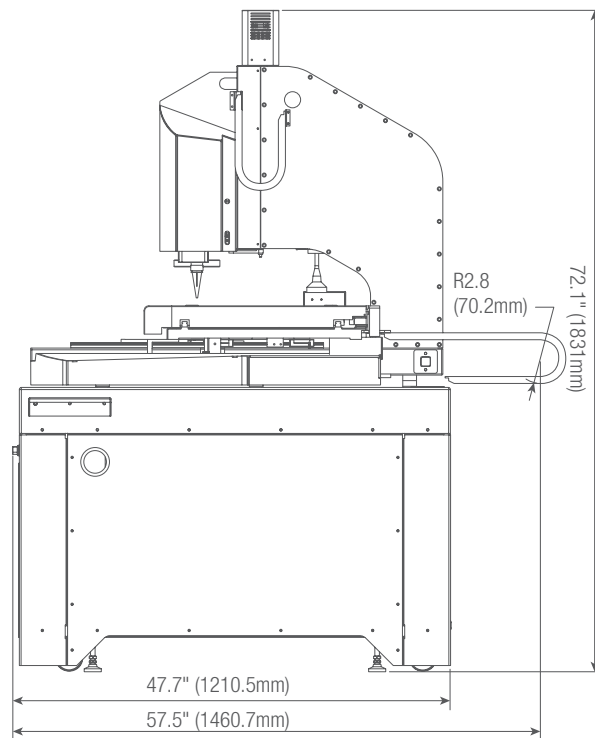
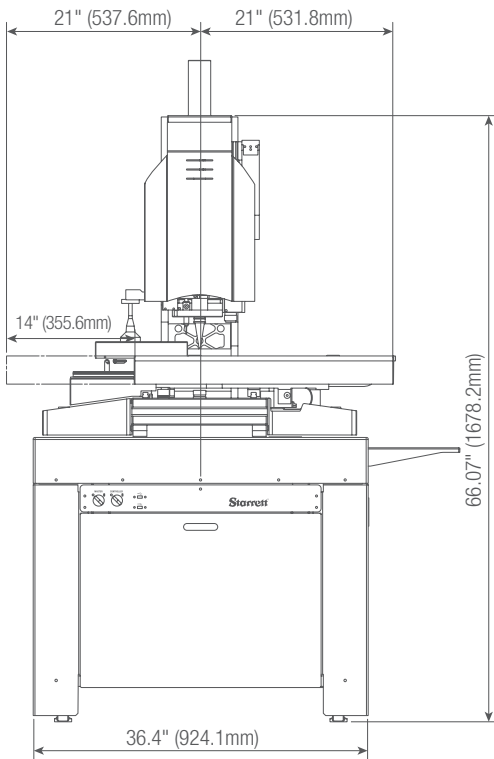

SPECIFICATIONS

| | AV350+ |
|-----------------|--------------------|
| Net Weight | 845lbs 384kg |
| Shipping Weight | 1300lbs 590kg |
| X-Y Accuracy | E2 = 2.5 + 5L/1000 |
| Z Accuracy | E1 = 2.5 + 5L/1000 |



LARGE FORMAT PREMIER

LF

LF AND LFM

Our LF Premier machines offer X-Y travel from 18" (460mm) to a generous 28" (711mm). Z travel is 8" (200mm). (Larger sizes available upon request.) Increased accuracy helps you verify critical dimensions. Ideal for use in QC labs, research, engineering, or manufacturing environments.

LF models utilize air-bearing and linear motor X-Y transport for ultra smooth, high speed positioning. LFM models are equipped with precision mechanical bearing linear guides driven by precision ground ball screws and servo motors.

LF OPTICS

| Optical Parameters | Dedicated Zoom Optics | |
|--------------------------------|---------------------------|----------------------------|
| | 6.5:1 | 12:1 |
| Optical magnification on CCD | 0.47x to 3.0x | 1.4x to 4.7x |
| Total magnification on monitor | 31x to 198x | 26x to 310x |
| Field of view width | .39 to .06" (10 to 1.6mm) | .44 to .047" (11 to 1.2mm) |
| Working distance | 3.47" (88mm) | 3.47" (86mm) |
| Camera CCD | 1/3" | 1/3" |

OPERATOR INTERFACE

| Feature | MetLogix™ M3 | QC5300 |
|---------------------------------|--------------|----------------------|
| 21.5" monitor with touch screen | x | |
| 21.5" monitor with desktop PC | x | x |
| External motion control unit | x | x |
| Windows®-based operating system | x | x |
| Wi-Fi network connectivity | x | x |
| CAD file import and export | x | x |
| Video edge detection | x | x |
| X-Y-Z measurements | x | x |
| 2D geometric constructs | x | x |
| 3D geometric constructs | | x |
| CNC control capability | x | x |
| Report generation and archiving | x | x |
| Software developer | MetLogix™ | Metronics/Heidenhain |



FEATURES AND SPECIFICATIONS

- Transports are driven on air bearings by hi-speed (up to 30" per second), zero maintenance, balanced linear motors, or precision mechanical linear bearings, which are close-looped to precision hi-resolution scales in all three axes
- Adjustable ergonomic workstation including a compact control panel and standard keyboard
- Massive granite base, bridge and mechanical or air-bearing ways for superior machine stability and precision
- Choice of QC5300 or MetLogix™ M3 Software or QC5000
- 21.5" monitor with QC5300 or M3 software
- LED Surface Ring Illumination
- LED Transmitted Illumination
- LED Coaxial Illumination
- Digital Video Color Camera: 1.2 MP, 1/3" SXVGA sensor

OPTIONS

- Dedicated 6.5:1 or 12:1 CNC zoom optics
- 0.5x, 1.5x and 2.0x auxiliary lenses for zoom optics
- Quadrant LED surface illumination
- DXF/FOV option for automatic comparison to CAD designs
- 24" (60cm) touch-screen monitor for M3
- CNC rotary axis fixture
- Renishaw touch probe kit
- Touch probe spotter camera for viewing critical placement of touch probe points as well as a touch probe changing rack (with QC5300)
- Calibration standards
- Part fixtures and work holding devices

LF DIMENSIONS

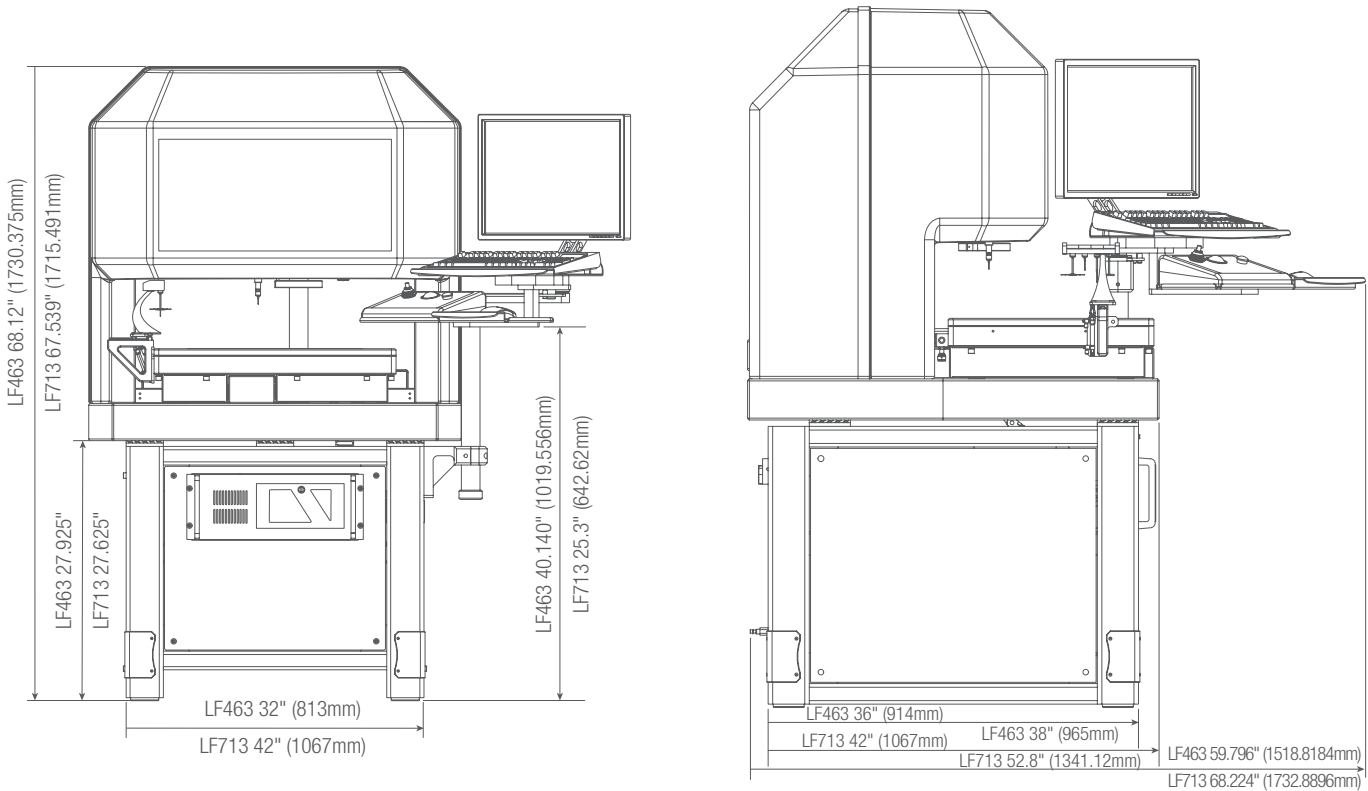

SPECIFICATIONS

| Model | LF463† | LF713† | LFM463* | LFM713* |
|------------------------|--------------------------------------|--------------------------------------|--------------------------------------|--------------------------------------|
| Dimensions (W x D x H) | 40 x 40 x 68" (102 x 102 x 173cm) | 50 x 64 x 68" (127 x 163 x 173cm) | 40 x 40 x 68" (102 x 102 x 173cm) | 50 x 64 x 68" (127 x 163 x 173cm) |
| Net Weight | 1500lb (726kg) | 2700lb (1225kg) | 1500lb (726kg) | 2700lb (1225kg) |
| Shipping Weight | 2300lb (1043kg) | 3600lb (1630kg) | 2300lb (1043kg) | 3600lb (1630kg) |
| Accuracy Stage X and Y | E2=2.5 + 5L/1000 | E2=2.5 + 5L/1000 | E2=3.5 + 5L/1000 | E2=3.5 + 5L/1000 |
| Accuracy Stage Z | E1=2.5 + 5L/1000 | E1=2.5 + 5L/1000 | E1=2.5 + 5L/1000 | E1=2.5 + 5L/1000 |

† Air Bearing

* Mechanical bearing



HORIZONTAL DIGITAL VIDEO COMPARATORS

HDV

HDV300 AND HDV400

HDV300 CNC, HDV400 CNC AND HDV500 CNC

The HDV Horizontal Digital Video Comparators combine the best features of a horizontal optical comparator and a vision metrology system. With a rigid steel design, they are configured like a traditional horizontal comparator. The workstage is the same as the Starrett field-proven comparators. The heart of the HDV system centers on a uniquely designed interchangeable lens mounting system coupled to a hi-resolution 5 mega-pixel digital video camera. The system is available with a choice of seven telecentric lenses for micron-level resolution and optical distortion as low as 0.001% for accurate field-of-view (FOV) measurements. With MetLogix™ M3 software DXF CAD files can be imported and 2D Go/No-Go digital overlays can be developed directly from the CAD files. Video edge detection (VED) allows real-time interaction of the imported file with the video image of the part being inspected. Productivity, speed and accuracy are all enhanced. Systems are available in manual or CNC control.

HDV300/400 OPTICS

| System Parameter | Telecentric Lenses | | | | | | | 6.5:1 Zoom Lens | |
|------------------------------|--------------------|--------------|--------------|---------------|---------------|---------------|---------------|-----------------|----------------|
| | 0.14x | 0.30x | 0.50x | 0.80x | 1.0x | 2.0x | 4.0x | 0.7x | 4.5x |
| Optical magnification | 0.14x | 0.30x | 0.50x | 0.80x | 1.0x | 2.0x | 4.0x | 0.7x | 4.5x |
| Magnification on 24" monitor | 8.6x | 18.5x | 21x | 49x | 62x | 124x | 247x | 58x | 363x |
| Field of view width | 2.36" (63mm) | 1.14" (29mm) | .59" (15mm) | .43" (11mm) | .35" (9mm) | .18" (4.3mm) | .09" (2.3mm) | .4" (11mm) | .05" (1.5mm) |
| Field of view height | 2.0" (51mm) | 0.94" (24mm) | 0.56" (14mm) | 0.35" (8.9mm) | 0.28" (7.1mm) | 0.14" (3.7mm) | 0.07" (1.8mm) | 0.40" (10.1mm) | 0.62" (15.6mm) |
| Working distance | 4.3" (110mm) | 4.3" (110mm) | 4.3" (110mm) | 4.3" (110mm) | 4.3" (110mm) | 4.3" (110mm) | 4.3" (110mm) | 3.4" (88mm) | 3.4" (88mm) |
| Optical Distortion, % | 0.001 | 0.001 | 0.002 | 0.002 | 0.005 | 0.005 | 0.006 | N/A | N/A |

OPERATOR INTERFACE

| Feature | MetLogix™ M3 |
|---------------------------------|--------------|
| PC installed in main housing | x |
| 24" color graphics touch screen | x |
| Windows®-based operating system | x |
| X-Y-Q (angle) measurements | x |
| 2D geometry software with skew | x |
| Video edge detection | x |
| CAD file import and export | x |
| FOV measurements | x |
| Elimination of overlays | x |
| 64-bit Intel® processor | x |
| Software developer | MetLogix™ |





FEATURES AND SPECIFICATIONS

- Steel construction with hard anodized stage tooling plate
- 21.3 x 5.1" (540 x 130mm) workstage
- 110lbs (50kg) maximum load capacity
- 2" (51mm) of focus travel
- Helix adjustment with $\pm 15^\circ$ Vernier scale
- Manual X-Y and focus positioning via hand wheels or CNC with joystick and trackball positioning
- Heidenhain glass scales for 0.5 μ m (.00002") X and Y resolution
- LED illumination for surface and profile lighting
- 5 mega-pixel color video camera (2448 x 2058 pixels)
- Software and part image displayed on 24" (60cm) touch-screen color monitor (1920 x 1080 pixels)

OPTIONS

- 6 interchangeable telecentric lenses for fields of view from 1.14 to 0.09 (29 to 2.3mm) (patent US 9,360,435 B2)
- Interchangeable 6.5:1 zoom optics
- Systems are also available with fixed .14x lens offering 2.5 x 1.9" (63 x 47mm) FOV. (Lenses are not interchangeable on this model)
- MetLogix™ M3 software with DXF/FOV option
- Optional CNC controls
- 23" or 32" purpose built cabinet stands
- Extensive line of calibration standards, work-holding devices and accessories

HDV300 / HDV400 DIMENSIONS

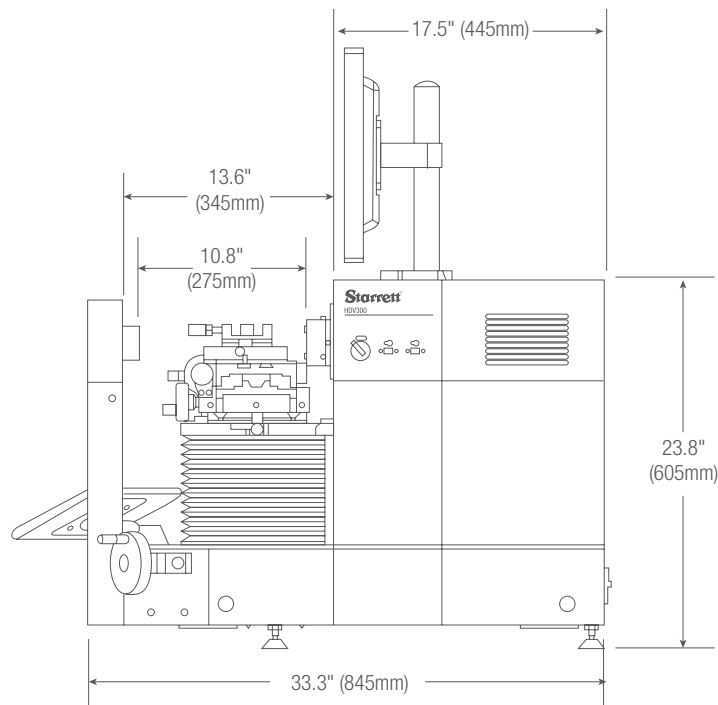
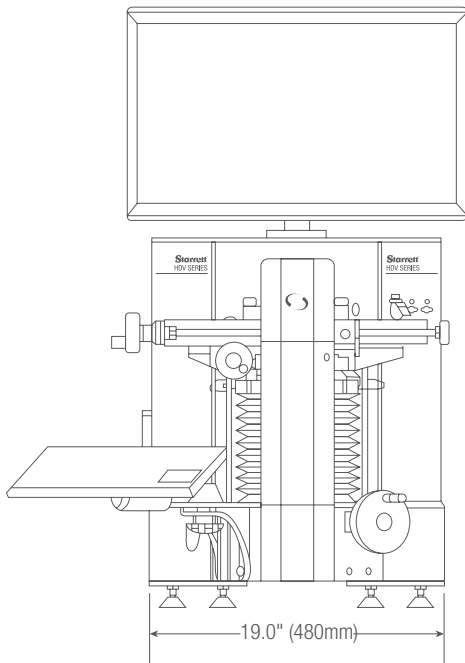

SPECIFICATIONS

| | HDV300 | HDV400 |
|-----------------|-------------------------|-------------------------|
| Net Weight | 220lbs 100kg | 230lbs 105kg |
| Shipping Weight | 430lbs 195kg | 440lbs 200kg |
| X-Y Travel | 12 x 6" 300 x 150mm | 16 x 6" 400 x 150mm |
| X-Y Accuracy | E2 = 3.0 μ m + L/33 | E2 = 3.0 μ m + L/33 |



NEW!

VISION SYSTEMS

HORIZONTAL DIGITAL VIDEO COMPARATORS

HDV

HDV500 CNC

The HDV500 CNC Digital Video Comparator offers the best features of a large, floor standing, horizontal optical comparator and a vision metrology system. The HDV500 has a long 20 x 8" X-Y stage and heavy-duty steel construction. The workstage is the same as the popular HF600 and HF750. The heart of the HDV system centers on a uniquely designed interchangeable lens mounting system (patent pending) to a hi-resolution 5 mega-pixel digital video camera. The HDV500 is available with zoom optics or a choice of three telecentric lens options for micron-level resolution and for accurate Field-of-View (FOV) measurements.

With MetLogix™ M3 Metrology software, DXF CAD files can be imported and 2D Go-No-Go digital overlays can be developed directly from the CAD files. Video edge detection (VED) allows real-time interaction of the imported file with the video image of the part being inspected. Productivity speed and accuracy are all enhanced.

HDV500 OPTICS

| System Parameter | Telecentric Lenses | | | 6.5:1 Zoom Lens | |
|--------------------------------|--------------------|--------------|--------------|-----------------|---------------|
| Optical magnification | 0.11x | 0.16x | 0.24x | 0.7x | 4.5x |
| Magnification on 42" monitor** | 6.5x | 9.3x | 14.7x | 41x* | 262x* |
| Field of view width | 3.0" (76mm) | 2.1" (54mm) | 1.4" (35mm) | 47" (12mm) | .40" (10mm) |
| Field of view height | 2.5" (64mm) | 1.8" (45mm) | 1.1 (29mm) | .46" (11.7mm) | .072" (1.8mm) |
| Working distance | 9.0" (228mm) | 6.25"(159mm) | 6.0" (150mm) | 140mm | 140mm |
| Optical Distortion, % | 0.02% | 0.03% | 0.04% | — | — |

*Best fit software setting

**Note that screen magnification is variable based on setting in M3 software

OPERATOR INTERFACE

| Feature | MetLogix™ M3 |
|---|--------------|
| PC installed in main housing | x |
| 42" (1070cm) color monitor | x |
| Windows®-based operating system (1080 pixels) | x |
| X-Y-Q (angle) measurements | x |
| 2D geometry software with skew | x |
| Video edge detection | x |
| CAD file import and export | x |
| FOV measurements | x |
| Elimination of overlays | x |
| 64-bit Intel® processor | x |
| Software developer | MetLogix™ |



FEATURES AND SPECIFICATIONS

- Steel construction with nickel plated stage tooling plate
- 21.3 x 5.1" (540 x 130mm) workstage top plate
- CNC controls
- 330lb (150kg) maximum load capacity
- 3" (75mm) of focus travel
- Helix angle adjustment with $\pm 15^\circ$ Vernier scale
- X-Y and focus positioning via joystick and trackball positioning
- Heidenhain glass scales for 0.5 μ m (.00002") X and Y resolution
- LED illumination for surface and profile lighting
- 5 mega-pixel black and white digital video camera (2448 x 2058 pixels)
- Floor standing model

OPTIONS

- 6.5:1 zoom optics interchangeable
- 3 interchangeable telecentric lenses for fields of view including - 1.4 x 1.1", 2.1 x 1.8" and 3.0 x 2.5" (patent pending)
- MetLogix™ profile fitting software
- Extensive line of accessories, workholding devices and calibration standards

HDV500 DIMENSIONS

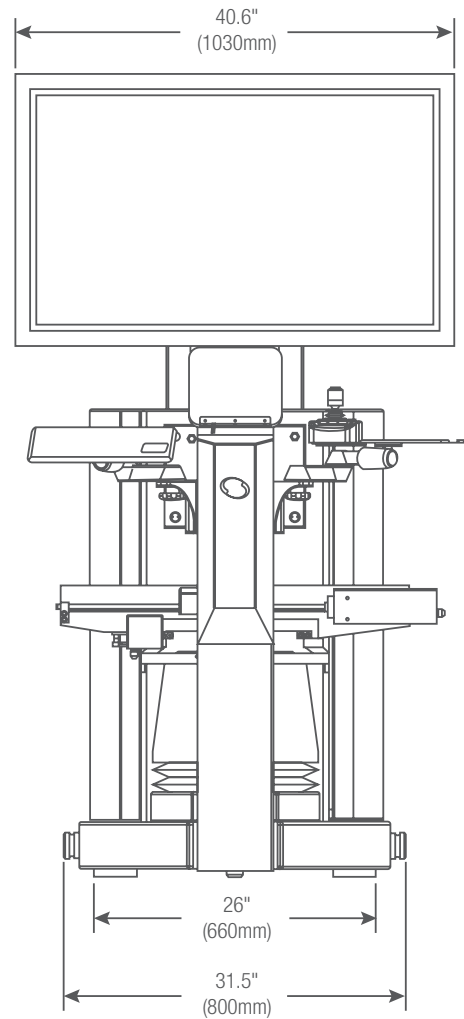
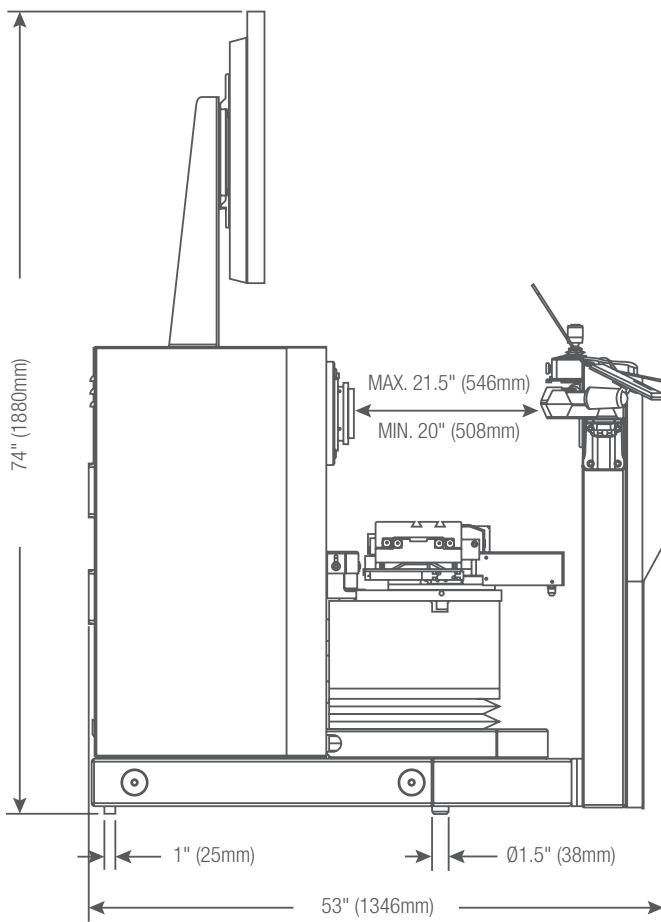

SPECIFICATIONS

| | HDV500 |
|-----------------|-------------------------|
| Net Weight | 1330lbs 600kg |
| Shipping Weight | 1400lbs 635kg |
| X-Y Travel | 20 x 8" 500 x 200mm |
| X-Y Accuracy | E2 = 3.0 μ m + L/33 |



SPECIFICATIONS AND OPTIONS

| Model | MV300 | MVR200 | MVR300 | AV300 | AV350 | AVR200 |
|--|----------------------|--------------------------------------|--------------------------------------|--|----------------------|--|
| Bench-Top System | X | X | X | X | – | X |
| Floor-Standing System | – | – | – | – | X | – |
| Part View Orientation | Vertical | Vertical | Vertical | Vertical | Vertical | Vertical |
| X-Y-Z Travel (in) | 12 x 6 x 5.5" | 8 x 4 x 8" | 12 x 8 x 8" | 12 x 6 x 5.5" | 14 x 14 x 8" | 8 x 4 x 8" |
| X-Y-Z Travel (mm) | 300 x 150 x 135mm | 200 x 100 x 200mm | 300 x 200 x 200mm | 300 x 150 x 135mm | 350 x 350 x 200mm | 200 x 100 x 200mm |
| Z Axis Measuring | Optional | Optional | Optional | Standard | Standard | Standard |
| CNC | – | – | – | Standard | Standard | Standard |
| X-Y Accuracy (µm) | E2 = 3.5µm + 5L/1000 | E2 = 2.5µm + 5L/1000 | E2 = 2.5µm + 5L/1000 | E2 = 1.9µm + 5L/1000 | E2 = 2.5µm + 5L/1000 | E2 = 1.9µm + 5L/1000 |
| Z Accuracy (µm) | E1 = 2.5µm + 5L/1000 | E1 = 2.5µm + 5L/1000 | E1 = 2.5µm + 5L/1000 | E1 = 2.5µm + 5L/1000 | E1 = 2.5µm + 5L/1000 | E1 = 2.5µm + 5L/1000 |
| Scale Resolution | 0.5µm | 0.5µm | 0.5µm | 0.1µm | 0.1µm | 0.1µm |
| Multi-Sensor Compatible | – | – | – | – | – | – |
| Base | Cast Aluminum | Granite | Granite | Cast Aluminum | Granite | Granite |
| Control System/Software | M3 | M3 | M3 | M3 or QC5300 | M3 | M3 |
| Display | 21.5" Touchscreen PC | 21.5" Touchscreen PC | 21.5" Touchscreen PC | 21.5" Touchscreen PC (M3) or 24" Monitor | 21.5" Touchscreen PC | 21.5" Touchscreen PC |
| Zoom Optics - Standard | 6.5:1 | 6.5:1 | 6.5:1 | 6.5:1 | 12:1 | 6.5:1 - 2 LED 12:1 - 3 LED |
| Zoom Optics - Optional | – | – | – | – | – | – |
| Telecentric Optics | – | – | – | – | – | – |
| Digital Video Camera | 1.3 MP Color | 1.3 or 2.0 MP Color with Telecentric | 1.3 or 2.0 MP Color with Telecentric | 1.3 MP Color | 1.3 MP Color | 1.3 MP Color Standard; 2 MP with Telecentric |
| Surface Ring Illumination | LED or Fiber Optic | LED | LED | LED or Fiber Optic | LED or Fiber Optic | LED |
| Transmitted Illumination | LED or Fiber Optic | LED | LED | LED or Fiber Optic | LED or Fiber Optic | LED |
| Coaxial Illumination - Optional | LED or Fiber Optic | LED | LED | LED or Fiber Optic | LED or Fiber Optic | LED |
| Auxiliary Lenses - Optional | 0.5x, 1.5x, 2.0x | 0.5x, 1.5x, 2.0x | 0.5x, 1.5x, 2.0x | 0.5x, 1.5x, 2.0x | 0.5x, 1.5x, 2.0x | 0.5x, 1.5x, 2.0x |
| Rotary Fixture | – | – | – | Optional | Optional | Optional |
| Renishaw Touch Probe | – | – | – | Optional | Optional | Optional |
| Renishaw Touch Probe Change Rack | – | – | – | – | – | – |
| Touch Probe Spotter Camera | – | – | – | – | – | – |
| Optimet Laser | – | – | – | – | – | – |
| Machine Pedestal and Point of Control Cart/Arm | – | – | – | – | Standard | – |
| Cabinet Stand | – | – | – | – | – | – |
| Workstation Base, Extension and Swing Arm | Optional | Optional | Optional | Optional | – | Optional |
| Part Fixturing | Optional | Optional | Optional | Optional | Optional | Optional |
| Dark Field Quadrant Illumination (LED only) | – | – | – | Optional | Optional | Optional |
| Video Pixel Calibration Standard | Optional | Optional | Optional | Optional | Optional | Optional |
| Calibration Standards | Optional | Optional | Optional | Optional | Optional | Optional |
| FOV, Linear and 2D Calibration Standards | Optional | Optional | Optional | Optional | Optional | Optional |



| AVR300 | AV300+ | AV350+ | LF and LFM | HDV300 | HDV400 | HDV500 |
|---|----------------------|----------------------|---|---|---|---|
| X | – | – | – | X | X | – |
| – | X | X | Standard | – | – | X |
| Vertical | Vertical | Vertical | Vertical | Horizontal | Horizontal | Horizontal |
| 12 x 8 x 8" | 12 x 6 x 8" | 14 x 14 x 8" | 18 x 12 x 8" 28 x 24 x 8" 38 x 30 x 8" Special Quote 50 x 36 x 8" Special Quote | 12 x 6" | 16 x 6" | 20 x 8" |
| 300 x 200 x 200mm | 300 x 150 x 200mm | 350 x 350 x 200mm | 460 x 305 x 200mm 711 x 610 x 200mm 965 x 760 x 200mm Special Quote 1270 x 915 x 200mm Special Quote | 300 x 150mm | 400 x 150mm | 500 x 200mm |
| Standard | Standard | Standard | Standard | – | – | – |
| Standard | Standard | Standard | Standard | Optional | Optional | Standard |
| E2 = 1.9µm + 5L/1000 | E2 = 1.9µm + 5L/1000 | E2 = 2.5µm + 5L/1000 | E2 = 1.5 + 5L/1000 on LF and 2.5 + 5L/1000 on LFM | E1 = 3.0µm + L33 | E1 = 3.0µm + L/33 | E1 = 3.0µm + L/33 |
| E1 = 2.5µm + 5L/1000 | E1 = 2.5µm + 5L/1000 | E1 = 2.5µm + 5L/1000 | E1 = 2.5 + 5L/1000 | – | – | – |
| 0.1µm | 0.1µm | 0.1µm | 0.1µm | 0.5µm | 0.5µm | 0.5µm |
| – | Yes | Yes | X | – | – | – |
| Granite | Granite | Granite | Granite | Steel | Steel | Steel |
| M3 | QC5300 | QC5300 | QC5300 or M3 | M3 | M3 | M3 |
| 21.5" Touchscreen PC | 24" Monitor | 24" Monitor | 24" Monitor | 24" Touch Screen | 24" Touch Screen | 42" Monitor |
| 6.5:1 - 2 LED 12:1 - 3 LED | 12:1 | 12:1 | 12:1 | – | – | – |
| – | – | – | 6.5:1 | 6.5:1 | 6.5:1 | – |
| – | – | – | – | Choice of 4.0x, 2.0x, 1.0x, 0.80x, 0.50x and 0.30x interchangeable Telecentric Lenses Optional- 0.14x fixed | Choice of 4.0x, 2.0x, 1.0x, 0.80x, 0.50x and 0.30x interchangeable Telecentric Lenses Optional- 0.14x fixed | Choice of 0.24x, 0.16x and 0.11x interchangeable Telecentric Lenses |
| 1.3 MP Color Standard; 2 MP with Telecentric | 1.3 MP Color | 1.3 MP Color | 1.3 MP Color | 5 MP Color | 5 MP Color | 5 MP Black and White |
| LED or Fiber Optic | LED or Fiber Optic | LED or Fiber Optic | LED | LED | LED | LED |
| LED or Fiber Optic | LED or Fiber Optic | LED or Fiber Optic | LED | LED | LED | LED |
| LED or Fiber Optic | LED or Fiber Optic | LED or Fiber Optic | LED | – | – | – |
| 0.5x, 1.5x, 2.0x | 0.5x, 1.5x, 2.0x | 0.5x, 1.5x, 2.0x | 0.5x, 1.5x, 2.0x | – | – | – |
| Optional | Optional | Optional | Optional | – | – | – |
| Optional | Optional | Optional | Optional | – | – | – |
| – | Optional | Optional | Optional | – | – | – |
| – | – | – | Optional | – | – | – |
| – | Optional | Optional | Optional | – | – | – |
| – | Standard | Standard | Standard | – | – | – |
| – | – | – | – | Optional | Optional | – |
| Optional | – | – | – | – | – | – |
| Optional | Optional | Optional | Optional | Optional | Optional | Optional |
| Optional | Optional | Optional | Optional | – | – | – |
| Optional | Standard | Standard | Standard | Optional | Optional | Optional |
| Optional | Optional | Optional | Optional | Optional | Optional | Optional |
| Optional | Optional | Optional | Optional | Optional | Optional | Optional |



ACCESSORIES



Fiber-optic and LED Illumination



Rotary part positioner with collet kit



Modular system work stands



Part Holding Fixtures



Touch Probe Kits



NIST Traceable Calibration Standards

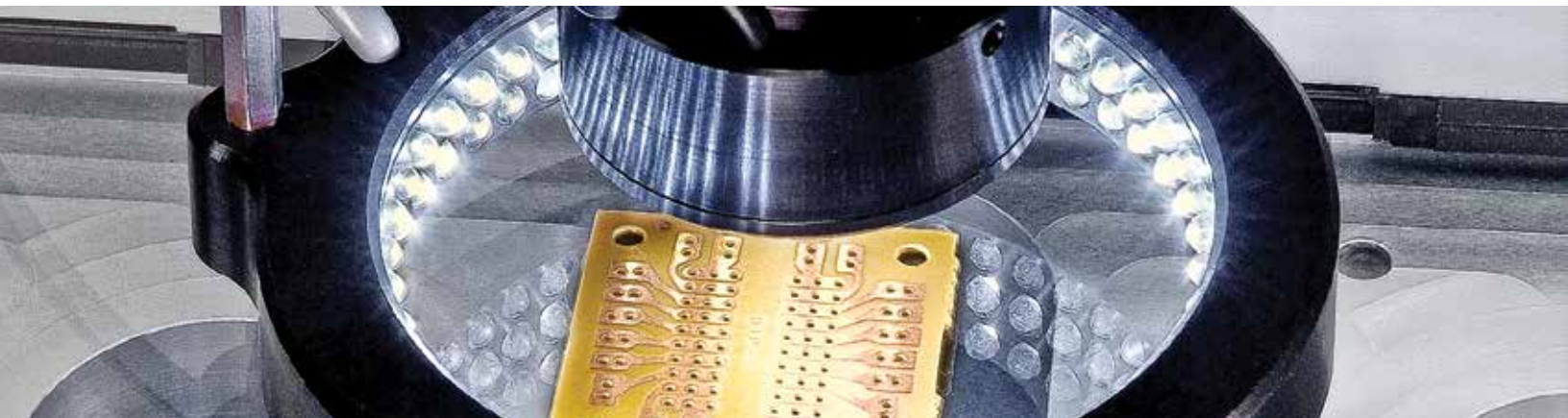

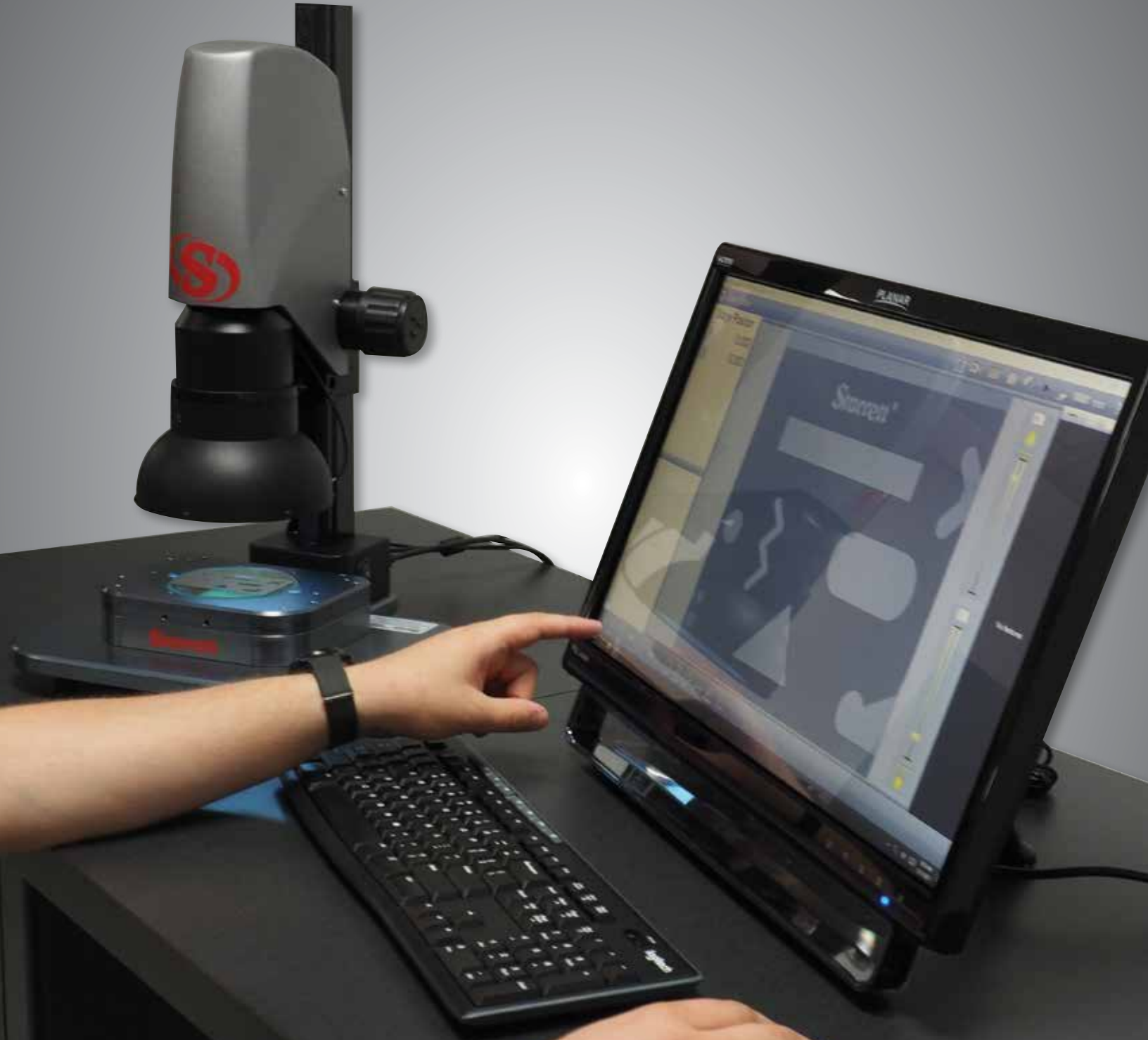

VIDEO INSPECTION SYSTEMS

VIDEO INSPECTION SYSTEMS

KINEMIC™

KMR

KineMic™ video microscopes are a family of seven versatile and affordable inspection and vision metrology systems. They are ideal for receiving inspection, quality assurance, training, manufacturing, assembly, research, and documentation – wherever easy setup and a range of magnifications are required. Depending on the size of the parts to be measured, measurements can be all electronic within the field of view, or be integrated with stage motion for parts up to 8" (200mm).

FEATURES

- XGA models set the standard for quick setup and ease of use by not requiring a computer
- D1 and M3 models offer the power of a 24" color touch-screen monitor and PC with MetLogix™ inspection and metrology software
- LED surface and transmitted illumination
- Small footprint takes up minimal space

Our KMR systems line provide high performance for low cost. These machines are simple to operate without compromising performance.

With seven models to choose from, we can customize to your specific needs.

Call (949) 348-1213 for an exact quote.



KMR-200 with M3



KMR-FOV-M3-0.14x

| | KineMic XGA Zoom, Basic | KineMic XGA Zoom, 2 x 2 Stage | KineMic D1 Zoom | KineMic D1 Zoom, 2 x 2 Stage | KineMic M3 Zoom, FOV | KineMic M3 Telecentric, FOV | KineMic M3 Zoom, 4 x 8 Stage |
|-------------------------------|-------------------------|-------------------------------|----------------------------------|----------------------------------|----------------------------------|---|----------------------------------|
| Part Number | KMR-XGA | KMR-50-XGA | KMR-D1 | KMR-50-D1 | KMR-Zoom-M3 | KMR-FOV-M3 | KMR-200-M3 |
| Optics | 6.5:1 zoom | 6.5:1 zoom | 6.5:1 zoom | 6.5:1 zoom | 6.5:1 zoom | 7 telecentric lenses | 6.5:1 zoom |
| CCD Sensor | 0.83 MPixel | 0.83 MPixel | 1.33 MPixel | 1.33 MPixel | 1.33 MPixel | 2.02 MPixel | 1.33 MPixel |
| Camera Interface | VGA cable | VGA cable | USB cable | USB cable | USB cable | USB cable | USB cable |
| Computer | N/A | N/A | PC | PC | PC | PC | PC |
| Software | N/A | N/A | MetLogix™ D1 | MetLogix™ D1 | MetLogix™ M3 | MetLogix™ M3 | MetLogix™ M3 |
| Video Screen | 19" XGA monitor | 19" XGA monitor | 24" touch-screen monitor with PC | 24" touch-screen monitor with PC | 24" touch-screen monitor with PC | 24" touch-screen monitor with PC | 24" touch-screen monitor with PC |
| Screen Resolution | 1024 x 768 | 1024 x 768 | 1920 x 1080 | 1920 x 1080 | 1920 x 1080 | 1920 x 1080 | 1920 x 1080 |
| Lens Magnification | 0.7x to 4.5x zoom | 0.7x to 4.5x zoom | 0.7x to 4.5x zoom | 0.7x to 4.5x zoom | 0.7x to 4.5x zoom | Telecentric Lenses: Choice of 0.14x, 0.3x, 0.5x, 0.8x, 1.0x and 4.0x magnifications | 0.7x to 4.5x zoom |
| Screen Magnification | 31x to 200x | 31x to 200x | 31x to 200x | 31x to 200x | 31x to 200x | 13x to 178x | 31x to 200x |
| Auxiliary lenses | 0.5x, 0.75x, 1.5x, 2x | 0.5x, 0.75x, 1.5x, 2x | 0.5x, 0.75x, 1.5x, 2x | 0.5x, 0.75x, 1.5x, 2x | 0.5x, 0.75x, 1.5x, 2x | N/A | 0.5x, 0.75x, 1.5x, 2x |
| Field of view (X-axis) | 1.4 to 9.0mm | 1.4 to 9.0mm | 1.4 to 9.0mm | 1.4 to 9.0mm | 1.4 to 9.0mm | 1.8 to 24mm | 1.4 to 9.0mm |
| X-Y Stage Motion | None | 50 x 50 mm | None | 50 x 50 mm | None | None | 200 x 100 mm |
| Metrology Means | None | Micrometers | D1 software** | D1 software** | M3 FOV software | M3 FOV software | X and Y encoders |
| Measurement Resolution | N/A | 1µm (.00005") | Up to 2µm* | 1µm (.00005") | Up to 2µm* | Up to 2µm* | 0.5µm (0.00002") |
| Meas. Accuracy | N/A | 3µm per 25mm | Up to ±2.5µm* | 3µm per 25mm | Up to ±2.5µm* | Up to ±2.5µm* | 2.5µm + 5L/1000 |
| Basic Stand | Standard | Standard | Standard | Standard | Standard | Standard | Standard |
| Boom Stand | Optional | N/A | Optional | N/A | Optional | N/A | N/A |
| LED Back Light | Standard | Standard | Standard | Standard | Standard | Standard | Standard |
| LED Ring Light | Standard | Standard | Standard | Standard | Standard | Standard | Standard |
| Lighting Control | Adjustment knobs | Adjustment knobs | Adjustment knobs | Adjustment knobs | Via M3 software | Via M3 software | Via M3 software |

* These are best values. Actual values will depend on the zoom lens setting or selected telecentric lens.

**D1 software basic measurements are taken by manually positioning a cross-hair on the screen.

Disclaimer: Due to continual product improvements, specifications may change without notice.



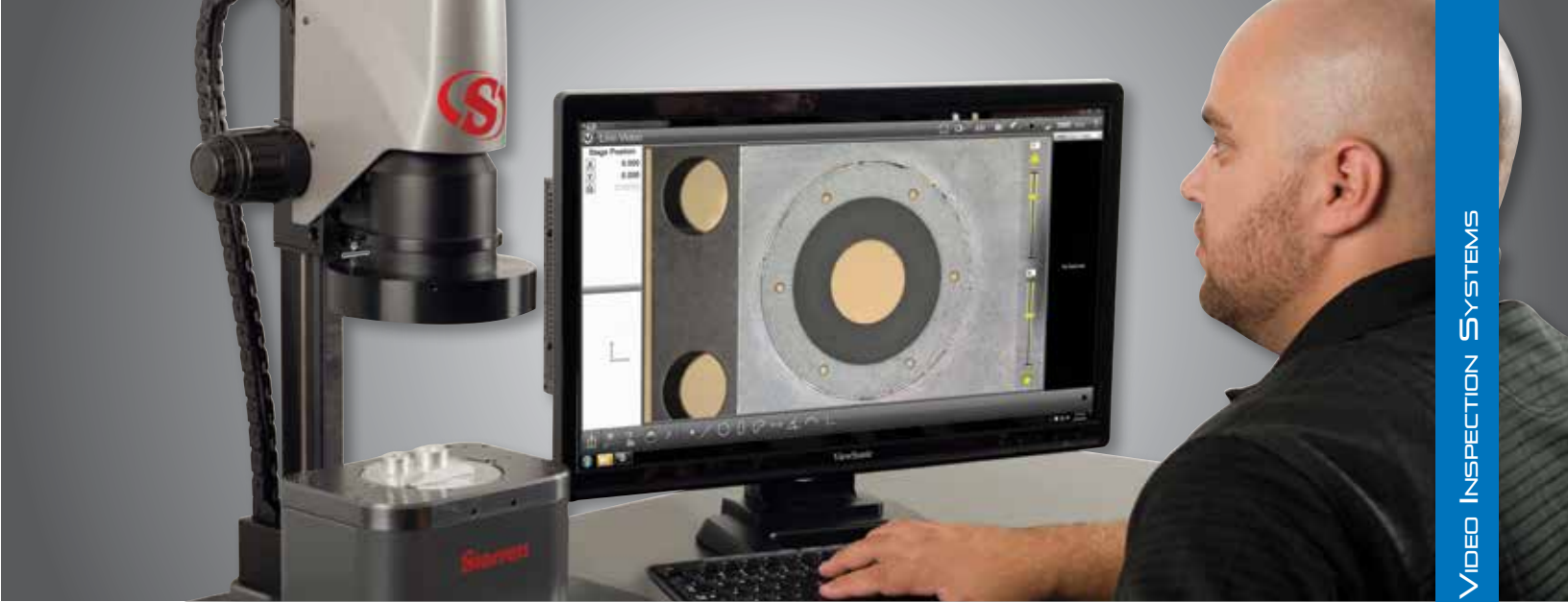

KMR-50-D1



KMR-XGA



KMR-D1



KMR-FOV with M3



| | KineMic XGA Zoom, Basic | KineMic XGA Zoom, 2 x 2 Stage | KineMic D1 Zoom | KineMic D1 Zoom, 2 x 2 Stage | KineMic M3 Zoom, FOV | KineMic M3 Telecentric, FOV | KineMic M3 Zoom, 4 x 8 Stage |
|-----------------------------|-------------------------|-------------------------------|-----------------|------------------------------|-----------------------|-----------------------------|------------------------------|
| Model Number | KMR-XGA | KMR-50-XGA | KMR-D1 | KMR-50-D1 | KMR-Zoom-M3 | KMR-FOV-M3 | KMR-200-M3 |
| Video Inspection | Yes | Yes | Yes | Yes | Yes | Yes | Yes |
| Basic Dimensions | No | Manual LCD Micrometer | Yes - Manual | Manual LCD Micrometer | VED - FOV measurement | VED - FOV measurement | VED - FOV measurement |
| Geometric Constructs | No | No | No | No | Yes | Yes | Yes |
| Image Annotation | No | No | Yes | Yes | Yes | Yes | Yes |
| Image Archiving | No | No | Yes | Yes | Yes | Yes | Yes |
| Video Edge Detection | No | No | No | No | Yes | Yes | Yes |





PRECISION MAKES THE DIFFERENCE

PURE PRECISION.

The combined powerful features of the Starrett MVR and AVR Vision Systems provide a multi-functional measurement and inspection system that will serve you for years to come.



Starrett®

(978) 249-3551 • starrett.com

Follow us!





OPTICAL COMPARATORS

HORIZONTAL BENCH-TOP OPTICAL COMPARATOR

HE400

The most economical of our bench top comparators, the HE400 offers a 16" (400mm) diameter screen, X-Y stage travel, choice of six bayonet-style fixed interchangeable lenses and Q-axis angular readout: all to improve capability and performance. These latest horizontal comparators are fitted with either MetLogix™ M1 or M2 measuring software or Quadra-Chek® digital readout systems as standard, making them simple to use, but having the power to satisfy the most complex measuring requirements.

OPERATOR INTERFACE

| Feature | MetLogix™ | | Quadra-Chek® | |
|--------------------------------|-----------|-----------|----------------------|----------------------|
| | M1 | M2 | QC121 | QC221 |
| Mounted to comparator arm | x | x | x | x |
| Color graphics | x | x | | |
| Touch screen operation | x | x | | |
| MS Windows® operating system | x | x | | |
| X-Y-Q axis digital readout | x | x | x | x |
| 2D geometry software with skew | x | x | x | x |
| Optical edge detection option | x | x | x | x |
| Software developer | MetLogix™ | MetLogix™ | Metronics/Heidenhain | Metronics/Heidenhain |



HE400

SPECIFICATIONS

| HE400 | |
|-------------------|----------------------------|
| Horizontal Travel | 10" (250mm) |
| Vertical Travel | 4" (100mm) |
| Focus Travel | 1-1/8" (28mm) |
| Top Plate* | 18.75 x 4.7" (480 x 120mm) |
| Image | Inverted and reversed |

*With machined single slot for easy fixturing





FEATURES AND SPECIFICATIONS

- All metal construction
- Single bayonet-style lens mounting system
- Collimating condenser with yellow/green filter and provision to mount further accessories
- Linear encoder (glass scale) with $.5\mu\text{m}$ on both X and Y axes
- LED profile and surface illumination
- Fully retractable flexible duplex fiber optic surface illumination
- Digital protractor for accurate angle measurement 1' resolution
- Available with MetLogix™ M1 tablet, M2 PC-based touch screen measuring software or Quadra-Chek® digital readout system
- 15.4lb (7kg) load capacity
- 18.75 x 4.74" (480 x 120mm) precision workstage top plate with machined slot for easy fixturing
- 10 x 4" (254 x 100mm) of XY stage travel
- 1-1/8" (8mm) focus travel
- Fine adjustment on all axes
- Quick release mechanism on the X-axis

OPTIONS

- Six interchangeable fixed magnification lenses including 10x, 20x, 25x, 31.25x, 50x and 100x
- Automatic fiber optic edge detection
- Canopy and curtains (designed to mount on Starrett cabinet stand)
- Purpose built cabinet stand
- Extensive line of accessories

HE400 DIMENSIONS

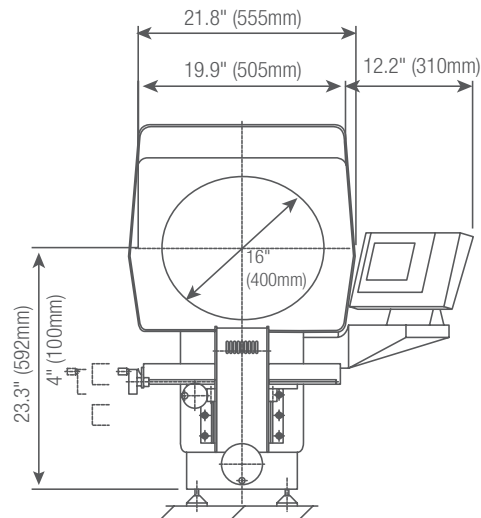
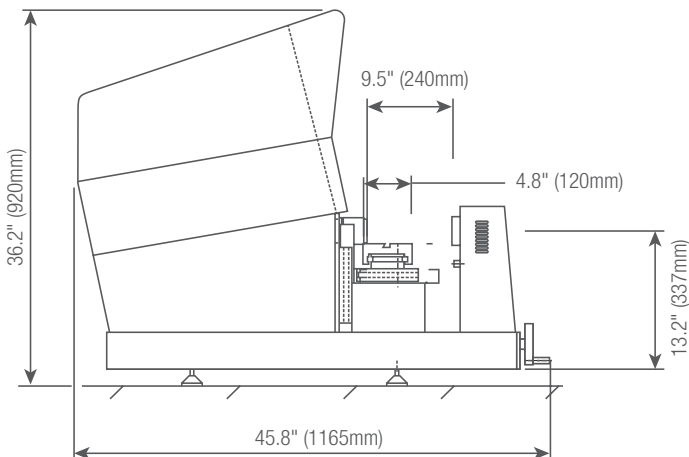

WEIGHT AND DIMENSIONS

| | HE400 |
|---------------------|-----------------------------|
| Net Weight | 230lbs 105kg |
| Shipping Weight | 300lbs 135kg |
| Shipping Dimensions | 49" (L) x 32" (W) x 51" (H) |



HORIZONTAL BENCH-TOP OPTICAL COMPARATOR

HB400

The HB400 Optical Comparator provides exceptional performance with a 16" (400mm) diameter viewing screen and 110lbs workstage load capacity. Available with optical and/or video edge detection which removes operator subjectivity in locating edges of parts being measured. A bayonet style lens mounting system accepts a choice of six fixed interchangeable lenses as well as the OV2 Zoom or TOV2 fixed telecentric magnification video camera systems. Motorized stage, fully automatic CNC controls and swing-away lamp house are all optional features. This comparator provides performance previously only available with floor standing models.

OPERATOR INTERFACE

| Feature | MetLogix™ | | | Quadra-Chek® | | |
|-----------------------------------|-----------|-----------|-----------|----------------------|----------------------|----------------------|
| | M1 | M2 | M3 | QC121 | QC221 | QC5200 |
| Mounted to comparator arm | x | x | | x | x | |
| Color graphics | x | x | x | | | |
| Touch screen operation | x | x | x | | | |
| Operating system | Android | Windows | Windows | | | |
| X-Y-Q axis digital readout | x | x | x | x | x | x |
| 2D geometry software with skew | x | x | x | x | x | x |
| Optical edge detection option | x | x | x | x | x | x |
| Video edge detection option | | | x | | | x |
| CAD file import and export option | | | x | | | x |
| CNC drive option | | x | x | | x | x |
| Software developer | MetLogix™ | MetLogix™ | MetLogix™ | Metronics/Heidenhain | Metronics/Heidenhain | Metronics/Heidenhain |



HB400

SPECIFICATIONS

| HB400 | |
|-------------------|-----------------------|
| Horizontal Travel | 12" (300mm) |
| Vertical Travel | 6" (150mm) |
| Focus Travel | 2" (50mm) |
| Top Plate* | 21 x 5" (530 x 120mm) |
| Image | Erect and reversed |

*With machined slots for easy fixturing





FEATURES AND SPECIFICATIONS

- All metal construction with hard-anodized stage tooling plate
- Single bayonet-style lens mounting system
- Collimating condenser with yellow/green filter and provision to mount further accessories
- Linear encoder (glass scale) on both X and Y axes
- LED profile and surface illumination
- Fixed duplex fiber optic surface illumination
- Digital protractor for accurate angle measurement (1' resolution) via Q-axis readout
- Available with MetLogix™ M1 tablet, M2 or M3 measuring software touch-screen and PC, or Quadra-Chek® digital readout system
- Fine adjustment on all axes
- Quick release mechanism on the X-axis

OPTIONS

- Six interchangeable fixed magnification lenses including 10x, 20x, 25x, 31.25x, 50x and 100x
- Optional 5x fixed or interchangeable lens system available by special order
- Optional extended travel workstage 16" (400mm)
- Automatic optical edge detection
- Automatic video edge detection (available only with OV2 or TOV2 video cameras)
- OV2 Video Camera with 6.5:1 zoom lens
- TOV2 Telecentric Video Camera with choice of 0.16x, 0.3x or 0.5x fixed magnification lens
- Motorized X and Y axes
- Fully automatic CNC controls
- Swing-away lamp house
- Canopy and curtains (designed to mount on Starrett cabinet stand)
- Purpose built cabinet stand
- Extensive line of accessories

HB400 DIMENSIONS

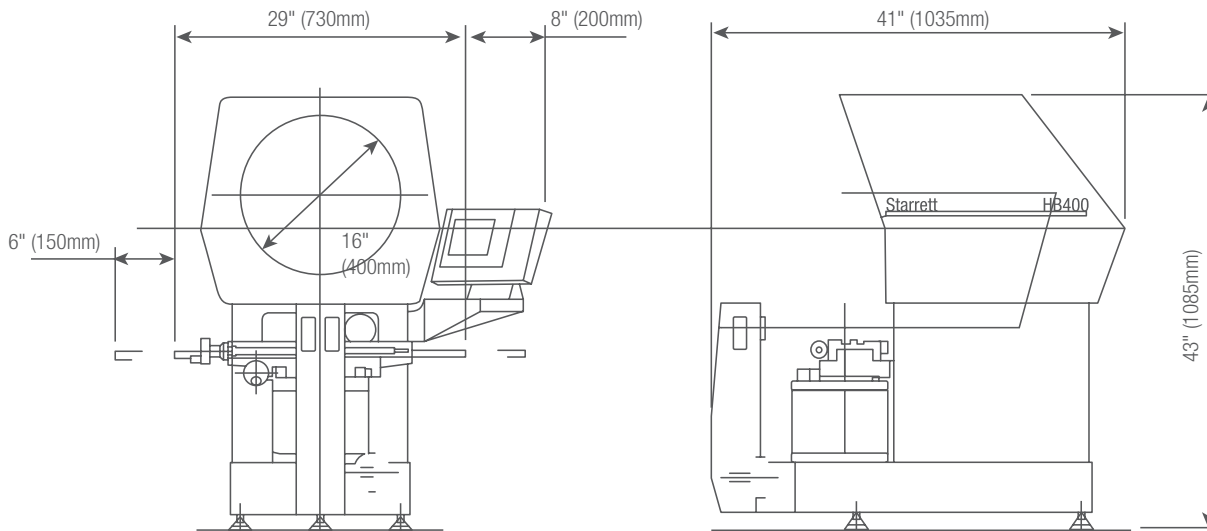

WEIGHT AND DIMENSIONS

| | HB400 |
|---------------------|-----------------------------|
| Net Weight | 320lbs |
| | 145kg |
| Shipping Weight | 385lbs |
| | 175kg |
| Shipping Dimensions | 49" (L) x 32" (W) x 51" (H) |



HORIZONTAL BENCH-TOP OPTICAL COMPARATOR

HD400

DUAL LENS

The HD400 is a dual lens optical comparator offering a two-lens mount allowing instant switching between two magnification lenses or video camera adaptor. The HD400 is equipped with a 16" (400mm) travel workstage as standard. Optional automatic edge detection or video edge detection removes operator subjectivity in locating edges of parts being measured. A bayonet style lens mounting system accepts a choice of six interchangeable lenses as well as our OV2 Zoom or TOV2 fixed telecentric magnification video camera systems. Motorized stage, fully automatic CNC controls and swing-away lamp house are all optional features.

OPERATOR INTERFACE

| Feature | MetLogix™ | | | Quadra-Chek® | |
|-----------------------------------|-----------|-----------|-----------|----------------------|----------------------|
| | M1 | M2 | M3 | QC221 | QC5200 |
| Mounted to comparator arm | x | x | | x | |
| Color graphics | x | x | x | | |
| Touch screen operation | x | x | x | | |
| Operating system | Android | Windows® | Windows® | | |
| X-Y-Q axis digital readout | x | x | x | x | x |
| 2D geometry software with skew | x | x | x | x | x |
| Optical edge detection option | x | x | x | x | x |
| Video edge detection option | | | x | | x |
| CAD file import and export option | | | x | | x |
| CNC drive option | | x | x | x | x |
| Software developer | MetLogix™ | MetLogix™ | MetLogix™ | Metronics/Heidenhain | Metronics/Heidenhain |



HD400

SPECIFICATIONS

| HD400 | |
|-------------------|-----------------------|
| Horizontal Travel | 16" (400mm) |
| Vertical Travel | 6" (150mm) |
| Focus Travel | 2" (50mm) |
| Top Plate* | 21 x 5" (530 x 120mm) |
| Image | Erect and reversed |

*With machined slots for easy fixturing





FEATURES AND SPECIFICATIONS

- All metal construction with hard-anodized stage tooling plate
- 16" (400mm) diameter screen
- Dual-lens mounting system
- Collimating condenser with yellow/green filter and provision to mount further accessories
- Linear encoder (glass scale) on both X and Y axes
- LED profile and surface illumination
- Fully retractable flexible duplex fiber optic surface illumination
- Digital protractor for accurate angle measurements (1' resolution) via Q-axis readout
- Helix adjustment for accurate thread form inspection
- Available with MetLogix™ M1 tablet, M2 or M3 PC-based touch screen measuring software or Quadra-Chek® digital readout system
- Fine adjustment on all axes
- Quick release mechanism on the X-axis

OPTIONS

- Six interchangeable fixed magnification lenses including 10x, 20x, 25x, 31.25x, 50x and 100x
- Optional 5x fixed lens system available by special order
- Automatic optical edge detection
- Automatic video edge detection (available only with OV2 or TOV2 video cameras)
- OV2 Video Camera with 6.5:1 zoom lens
- TOV2 Telecentric Video Camera with choice of 0.16x, 0.3x, or 0.5x fixed magnification lens
- Motorized X and Y axes
- Fully automatic CNC controls
- Swing-away lamp house
- Canopy and curtains (designed to mount on Starrett cabinet stand)
- Purpose built cabinet stand
- Extensive line of accessories

HD400 DIMENSIONS

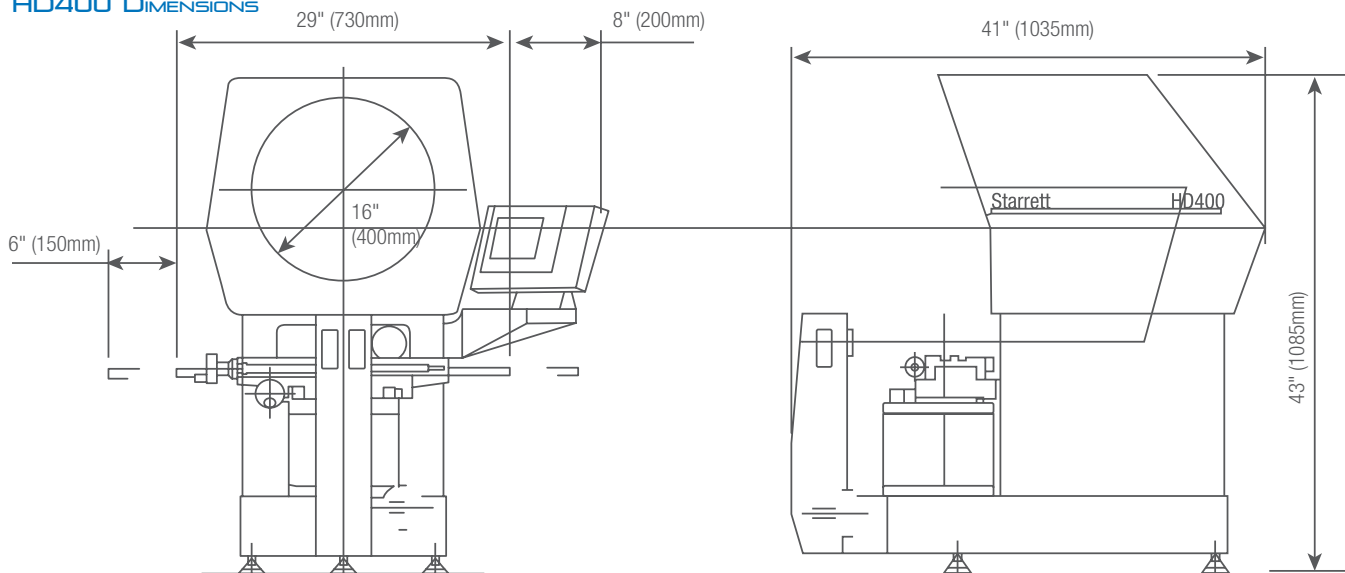

WEIGHT AND DIMENSIONS

| | HD400 |
|---------------------|-----------------------------|
| Net Weight | 320lbs 145kg |
| Shipping Weight | 385lbs 175kg |
| Shipping Dimensions | 49" (L) x 32" (W) x 51" (H) |



NEW!

OPTICAL COMPARATORS

VERTICAL BENCH-TOP OPTICAL COMPARATOR

VB300

The VB300 is another optical comparator with the Starrett trademark formula: high performance at a low cost. This vertical bench top comparator is designed to meet the demands of modern industry and is ideal for the rapid inspection of small light-weight components, stampings, plastic molding, electronic components, small turned parts and more. The VB300 features a variety of digital displays making the VB300 easy to use and have the power to satisfy the most complex of measuring requirements.

OPERATOR INTERFACE

| Feature | Integral LED readout | MetLogix™ M1 | M2 | Quadra-Chek® QC121 | QC221 |
|--|----------------------|-----------------|-----------|-----------------------|----------------------|
| Angular digital measurement in readout | x | | | | |
| Mounted to comparator arm | | x | x | x | x |
| Color graphics | | x | x | | |
| Touch screen operation | | x | x | | |
| Operating system | | Android | Windows® | | |
| X-Y-Q axis digital readout | x | x | x | x | x |
| 2D geometry software with skew | | x | x | x | x |
| Optical edge detection option | | x | x | x | x |
| Software developer | | MetLogix™ | MetLogix™ | Metronics/Heidenhain | Metronics/Heidenhain |



SPECIFICATIONS

| VB300 | |
|-------------------|----------------------|
| Horizontal Travel | 4" (100mm) |
| Vertical Travel | 4" (100mm) |
| Focus Travel | 3.5" (90mm) |
| Top Plate* | 9 x 9" (225 x 225mm) |
| Glass Insert | 6 x 6" (150 x 150mm) |
| Image | Reversed |

*With machined slot for easy fixturing



FEATURES AND SPECIFICATIONS

- All metal construction for optimum performance
- 12" (300mm) diameter screen with overlay clips
- Linear encoder (glass scale) on both X and Y axes
- Stage weight capacity: 11 lbs (5kg) (evenly distributed)
- LED profile and surface illumination
- Screen driven Q-axis
- Quick release mechanism on X-axis and Y-axis
- Available with a simple integrated LED readout display or choice of the new MetLogix™ M1 tablet, M2 PC-based measuring software, or Quadra-Chek® digital readout systems

OPTIONS

- Choice of four fixed magnification lenses including 10x, 20x, 25x and 50x
- Purpose built cabinet stand
- Precision Centers and Veers accessory available

VB300 DIMENSIONS

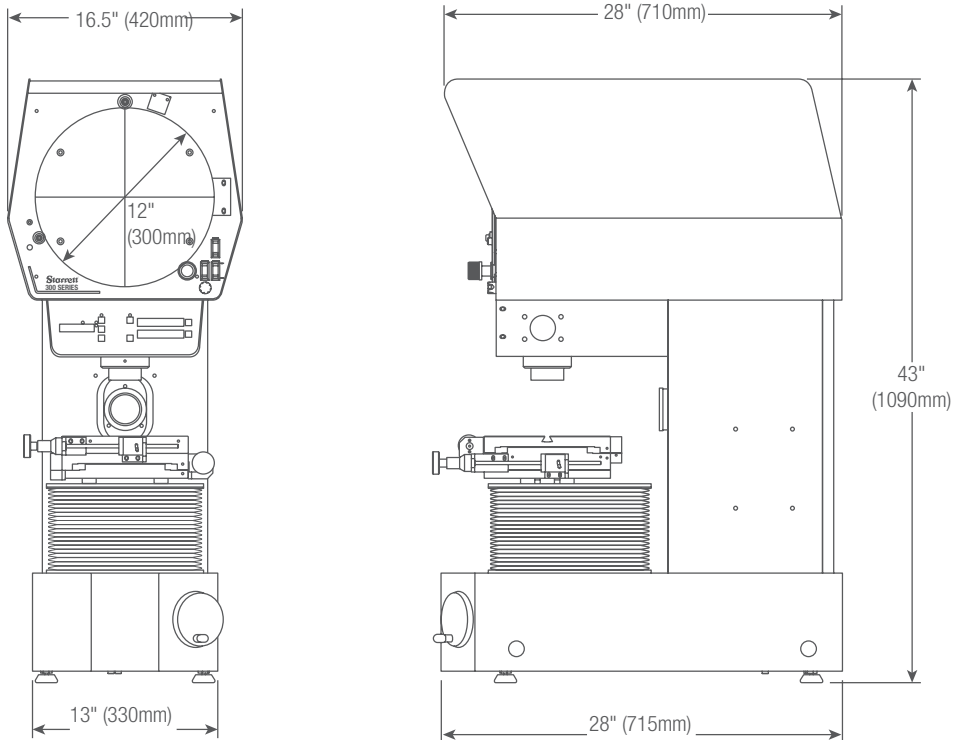

WEIGHT AND DIMENSIONS

| | VB300 |
|------------------------------|-----------------|
| Net Weight | 423lbs 192kg |
| Shipping Weight | 443lbs 201kg |
| Gross Dimensions (L x W x H) | 44 x 33 x 52" |





VERTICAL BENCH-TOP OPTICAL COMPARATOR

VB400

The VB400 Vertical Optical Comparator allows flat parts to be simply laid on a glass insert in the workstage. Features include a 16" (400mm) diameter vertical screen, ultra-bright LED profile and surface illumination, and linear encoder scales for 0.5µm resolution.

OPERATOR INTERFACE

| Feature | MetLogix™ | | Quadra-Chek® | |
|--------------------------------|-----------|-----------|----------------------|----------------------|
| | M1 | M2 | QC121 | QC221 |
| Mounted to comparator arm | x | x | x | x |
| Color graphics | x | x | | |
| Touch screen operation | x | x | | |
| Operating system | Android | Windows® | | |
| X-Y-Q axis digital readout | x | x | x | x |
| 2D geometry software with skew | x | x | x | x |
| Optical edge detection option | x | x | x | x |
| Software developer | MetLogix™ | MetLogix™ | Metronics/Heidenhain | Metronics/Heidenhain |



VB400

SPECIFICATIONS

VB400

| | |
|-------------------|------------------------------|
| Horizontal Travel | 8" (200mm) |
| Vertical Travel | 4" (100mm) |
| Focus Travel | 4" (100mm) |
| Top Plate* | 16 x 9" (400 x 230mm) |
| Glass Insert | 9-1/4 x 5-1/2" (235 x 140mm) |
| Image | Reversed |

*With machined slot for easy fixturing



FEATURES AND SPECIFICATIONS

- All metal construction
- 16" (400mm) diameter screen
- Collimating condenser with yellow/green filter and provision to mount further accessories
- Linear encoder (glass scale) on both X and Y axes
- LED profile and surface illumination
- Digital protractor for accurate angle measurements (1' resolution) via Q-axis readout
- Available with MetLogix™ M1 tablet, M2 PC-based touch screen measuring software or Quadra-Chek® digital readout system
- Fine adjustment on all axes
- Quick release mechanism on the X-axis

OPTIONS

- Choice of six fixed magnification lenses including 10x, 20x, 25x, 31.25X, 50x and 100x
- Canopy and curtains (designed to mount on Starrett cabinet stand)
- Purpose built cabinet stand
- Work holding accessories

VB400 DIMENSIONS

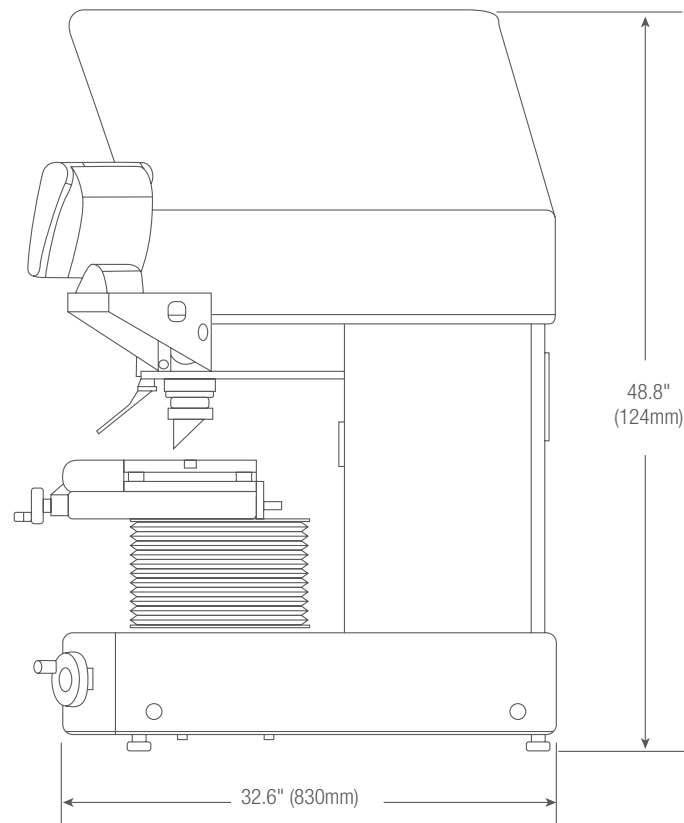
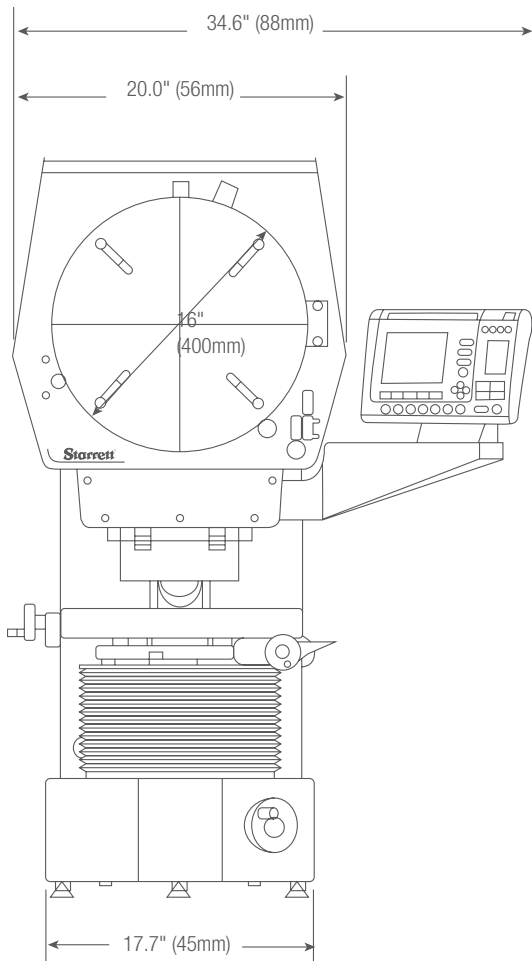

WEIGHT AND DIMENSIONS

| | VB400 |
|---------------------------------|-----------------|
| Net Weight | 423lbs 192kg |
| Shipping Weight | 443lbs 201kg |
| Shipping Dimensions (L x W x H) | 49 x 32 x 51" |



VERTICAL FLOOR STANDING OPTICAL COMPARATOR

VF600

If your measuring requirements demand the use of a large screen vertical axis comparator, then look no further than the VF600. Ideal for the larger components found in the electronics, stamping, and extrusion industries, the VF600 is the ultimate in vertical axis optical comparators; a design based on years of knowledge in the manufacture of high performing optical comparators.

OPERATOR INTERFACE

| Feature | MetLogix™ M2 | Quadra-Chek® QC221 |
|--------------------------------|-----------------|-----------------------|
| Mounted to comparator arm | x | x |
| Color graphics | x | |
| Touch screen operation | x | |
| Operating system | Windows® | |
| X-Y-Z axis digital readout | x | x |
| 2D geometry software with skew | x | x |
| Optical edge detection option | x | x |
| Software developer | MetLogix™ | Metronics/Heidenhain |



VF600

SPECIFICATIONS

| VF600 | |
|-------------------|------------------------------|
| Horizontal Travel | 8" (200mm) |
| Vertical Travel | 4" (100mm) |
| Focus Travel | 4" (100mm) |
| Top Plate* | 16 x 9" (400 x 230mm) |
| Glass Insert | 9-1/4 x 5-1/2" (235 x 140mm) |
| Image | Inverted and reversed |

*With machined slots for easy fixturing



FEATURES AND SPECIFICATIONS

- Available with MetLogix™ M1 tablet, M2 measuring software with touch-screen with PC, or Quadra-Chek® digital readout system
- Screen is angled 30° from horizontal for clear, easy viewing
- Projection lens turret with three lens capacity (lenses not included)
- Turret mounted condenser system complete with two lenses and yellow/green filter with provision to mount further accessories
- Full canopy and curtains
- Linear encoder (glass scale) on both X and Y axes

OPTIONS

- Choice of five fixed magnification lenses including 10x, 20x, 25x, 50x and 100x
- 5x fixed lens by special order
- Automatic edge detection
- Motorized X-Y axis
- Fully automatic CNC controls

VF600 DIMENSIONS

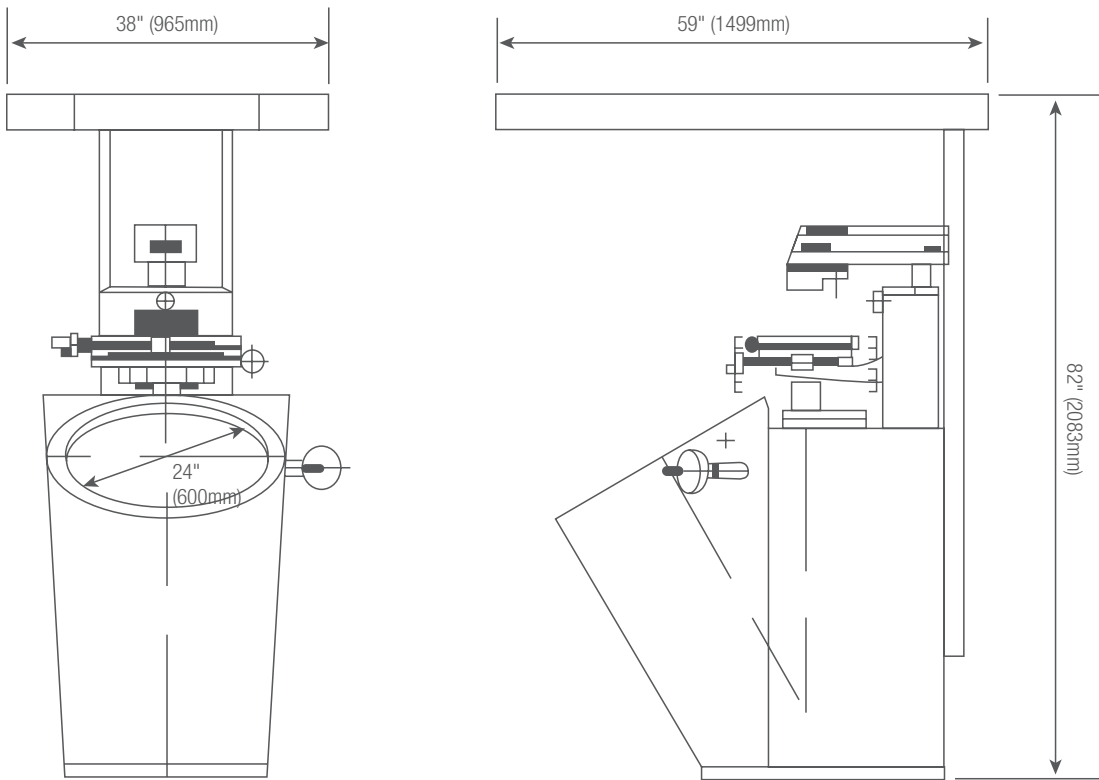

WEIGHT AND DIMENSIONS

| | VF600 |
|---------------------|------------------------------------|
| Net Weight | 507lbs 230kg |
| Shipping Weight | 937lbs 425kg |
| Shipping Dimensions | 60 x 47 x 81" 152 x 120 x 206cm |





HORIZONTAL FLOOR STANDING OPTICAL COMPARATOR

HF600

Well known throughout the world for superior value and exceptional measuring performance across the full measuring range and at all magnifications, the HF600 sets the standard in all applications from the QC lab to the production floor. The HF600 comparator has a four-position lens turret for instant selection of optional magnification lenses. Inserting the optional OV2 or TOV2 Video Camera System converts the comparator into a video metrology system. Ideal for use over a broad spectrum of industries and applications, the HF600 is designed and built to satisfy the requirements of measuring small to large work pieces with total precision, ruggedness, and efficiency. The HF600 utilizes 2D measurement software for geometries like diameters, radius, angles, lines, points, and for skew correction. Advanced software can also provide many tools such as CAD file import, CAD data export for reverse engineering, standard and custom reports, and Ethernet networking.

OPERATOR INTERFACE

| Feature | MetLogix™ M2 | M3 | Quadra-Chek® QC221 | QC5200* |
|-----------------------------------|-----------------|-----------|-----------------------|----------------------|
| Mounted to comparator arm | x | | x | |
| Color graphics | x | x | | x |
| Touch screen operation | x | x | | |
| Operating system | Windows® | Windows® | | |
| X-Y-Q axis digital readout | x | x | x | x |
| 2D geometry software with skew | x | x | x | x |
| Optical edge detection option | x | x | x | x |
| Video edge detection option | | x | | x |
| CAD file import and export option | | x | | x |
| CNC drive option | x | | x | x |
| Software developer | MetLogix™ | MetLogix™ | Metronics/Heidenhain | Metronics/Heidenhain |

*Available with either optical edge detection or video edge detection



SPECIFICATIONS

| HF600 | |
|-------------------|-----------------------|
| Horizontal Travel | 12" (300mm) |
| Vertical Travel | 8" (200mm) |
| Focus Travel | 3" (75mm) |
| Top Plate* | 25 x 9" (635 x 230mm) |
| Image | Erect and reversed |

*With machined slots for easy fixturing



FEATURES AND SPECIFICATIONS

- All metal construction with nickel plated stage tooling plate
- 24" (600mm) diameter screen with precision cross lines and overlay clips
- Motorized X and Y axes standard
- Two-axis power drive via joystick and variable speed control for fine adjustment
- Projection lens turret with four lens capacity (lenses not included)
- Turret mounted condenser system and yellow/green filter and provision to mount further accessories
- Stage Weight Capacity: 330lbs (150kg) (evenly distributed)
- Workstage capacity between centers: 17.5" (440mm)
- Fully retractable duplex fiber optic surface illumination
- 0.001mm resolution Heidenhain linear scales
- Screen driven rotary Q-axis with 1' resolution
- Available with MetLogix™ M1 tablet, M2 or M3 measuring software with touch screen and PC, or Quadra-Chek® digital readout systems
- Complete with full canopy and curtains

OPTIONS

- Six interchangeable lens magnification including 10x, 20x, 25x, 31.25x, 50x and 100x
- Optional 5x fixed or 5x interchangeable on a 3-lens turret available by special order
- Interchangeable OV2 video camera system with a 6.5:1 zoom lens
- Interchangeable TOV2 telecentric video camera systems with choice of 0.16x, 0.3x or 0.5x fixed magnification lenses
- Extended Stage Travel: 20" (500mm) X-axis; 8" (200mm) Y-axis
- Fully automatic CNC controls
- Automatic Optical Edge Detection
- Automatic Video Edge Detection available only with OV2 and TOV2 video camera systems
- Swing-away lamp house
- Extensive line of accessories

HF600 DIMENSIONS

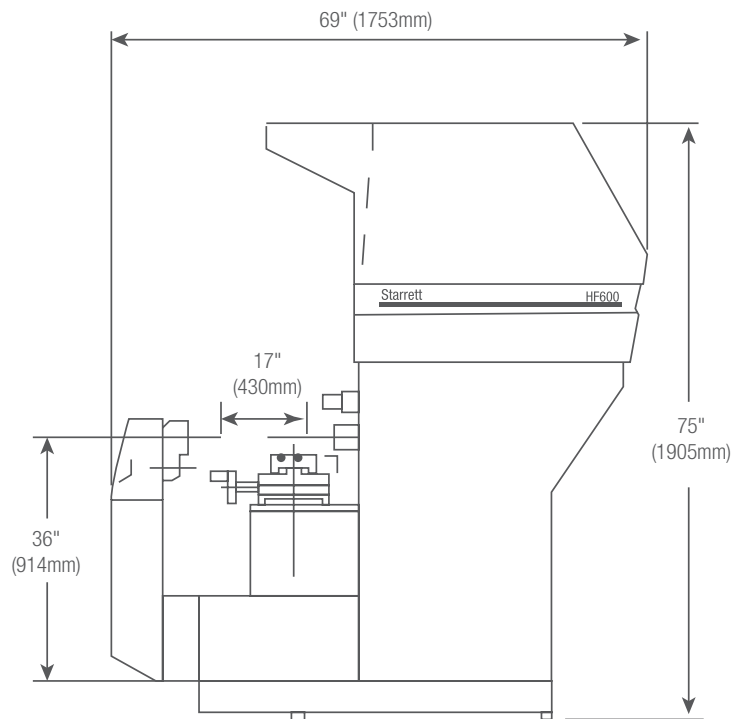
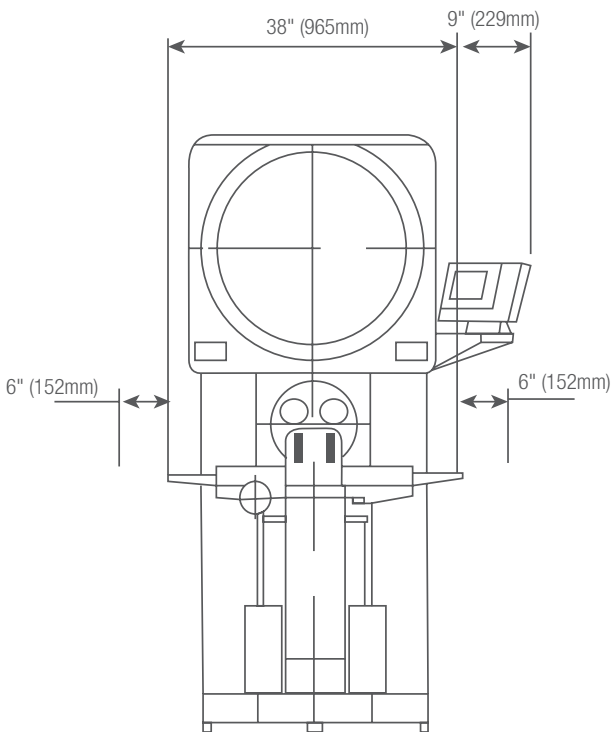

WEIGHT AND DIMENSIONS

| | HF600 |
|-------------------|------------------------------------|
| Net Weight | 1340lbs 610kg |
| Shipping Weight | 1500lbs 680kg |
| Crated Dimensions | 81 x 49 x 89" 206 x 125 x 226cm |





HORIZONTAL FLOOR STANDING OPTICAL COMPARATOR

HF750

Utilizing the same exemplary build standards as the HF600, the HF750 super capacity optical comparator delivers benefits from an even larger 30" (762mm) screen, setting a new standard for clarity and brightness. Ideal for use over a broad spectrum of industries and applications, the HF750 is designed and built to satisfy the requirements of measuring small to large work pieces with total precision, ruggedness, and efficiency. The geometric software measures diameter, radius, angle, line and point features, plus part skewing for faster setup. The HF750 is available with optical edge detection or video edge detection with advanced software and OV2 or TOV2 video camera options.

OPERATOR INTERFACE

| Feature | MetLogix™ | | Quadra-Chek® | |
|-----------------------------------|-----------|-----------|----------------------|----------------------|
| | M2 | M3 | QC221 | QC5200* |
| Mounted to comparator arm | x | | x | |
| Color graphics | x | x | | x |
| Touch screen operation | x | x | | |
| Operating system | Windows® | Windows® | | |
| X-Y-Z axis digital readout | x | x | x | x |
| 2D geometry software with skew | x | x | x | x |
| Optical edge detection option | x | x | x | x |
| Video edge detection option | | x | | x |
| CAD file import and export option | | x | | x |
| CNC drive option | x | x | x | x |
| Software developer | MetLogix™ | MetLogix™ | Metronics/Heidenhain | Metronics/Heidenhain |

*Available with either optical edge detection or video edge detection



SPECIFICATIONS

| HF750 | |
|-------------------|-----------------------|
| Horizontal Travel | 12" (300mm) |
| Vertical Travel | 8" (200mm) |
| Focus Travel | 3" (75mm) |
| Top Plate* | 25 x 9" (635 x 230mm) |
| Image | Erect and reversed |

*With machined slots for easy fixturing



FEATURES AND SPECIFICATIONS

- All metal construction with nickel plated stage tooling plate
- 30" (762mm) diameter screen with precision cross lines and overlay clips
- Motorized X and Y axes standard
- Two-axis power drive via joystick and variable speed control for fine adjust
- Projection lens turret with three lens capacity (lenses not included)
- Turret mounted condenser system and yellow/green filter and provision to mount further accessories
- Stage Weight Capacity: 330lbs (150kg) (evenly distributed)
- Workstage capacity between centers 17.5" (440mm)
- Fully retractable duplex fiber optic surface illumination
- Halogen profile and surface illumination
- 0.001mm resolution Heidenhain linear scales
- Screen driven rotary Q-axis with 1' resolution
- Available with MetLogix™ tablet, M2 measuring software with touch screen and PC, or Quadra-Chek® digital readout systems
- Complete with full canopy and curtains

OPTIONS

- Six interchangeable lens magnifications including 10x, 20x, 25x, 31.25x, 50x and 100x
- Optional 5x fixed or 5x interchangeable on a 3-lens turret available by special order
- Interchangeable OV2 video camera system with 6.5:1 zoom lens
- Interchangeable TOV2 telecentric video camera systems with choice of 0.16x, 0.3x or 0.5x fixed magnification lenses
- Extended Stage Travel: 20" (500mm) X-axis; 8" (200mm) Y-axis
- Fully automatic CNC controls
- Automatic Optical Edge Detection
- Automatic Video Edge Detection available only with OV2 and TOV2 video camera systems
- Swing-away lamp house
- Extensive line of accessories

HF750 DIMENSIONS

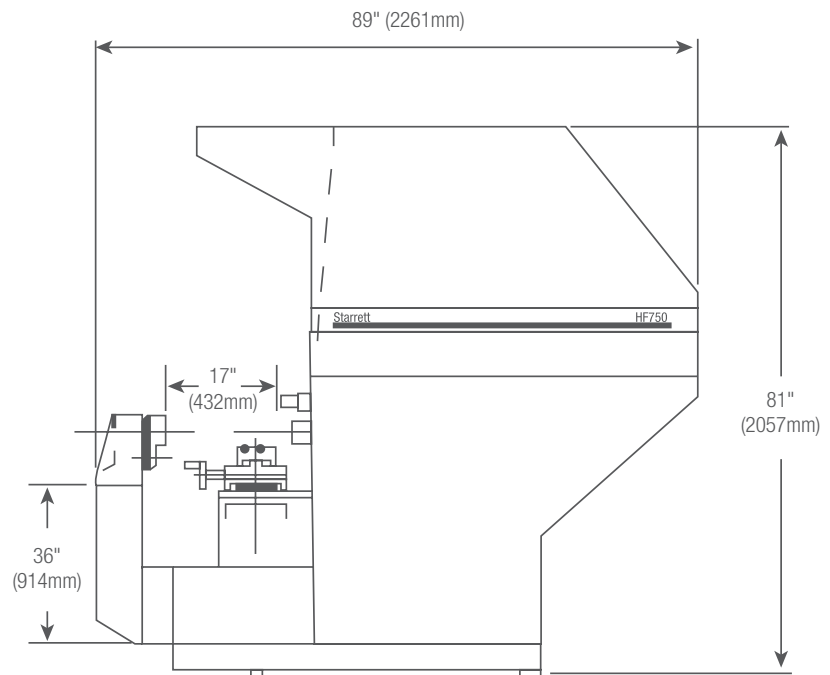
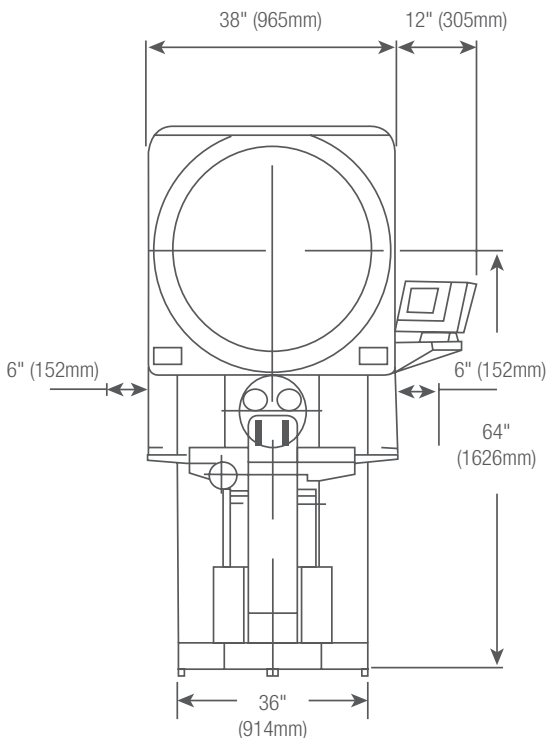

WEIGHT AND DIMENSIONS

| | HF750 |
|-------------------|------------------------------------|
| Net Weight | 1660lbs 753kg |
| Shipping Weight | 1800lbs 817kg |
| Crated Dimensions | 96 x 48 x 91" 244 x 124 x 231cm |



SIDE BED OPTICAL COMPARATORS

HS600

The HS600 floor-standing horizontal optical comparator has all the same features as the HF600, except it has the screen position set to the side of the workstage area allowing close, comfortable and unrestricted access to the viewing and control area. A time tested, cost-effective solution for non-contact measurement. At the heart of these systems are precision optics, superb lighting, and a highly accurate workstage that combine to ensure bright, sharp images and exceptional accuracy. The HS600 is simple to use, yet has excellent capacity and performance to satisfy an exceptionally wide range of dimensional inspection applications and complex measuring requirements.

OPERATOR INTERFACE

| Feature | MetLogix™ | | Quadra-Chek® | |
|-----------------------------------|-----------|-----------|----------------------|----------------------|
| | M2 | M3 | QC221 | QC5200* |
| Mounted to comparator arm | x | | x | |
| Color graphics | x | x | | x |
| Touch screen operation | x | x | | x |
| Operating system | Windows® | Windows® | | |
| X-Y-Q axis digital readout | x | x | x | x |
| X-Y axis digital readout | | | | |
| 2D geometry software with skew | x | x | x | x |
| Optical edge detection option | x | x | x | x |
| Video edge detection option | | x | | x |
| CAD file import and export option | | x | | |
| CNC drive option | x | x | x | x |
| Software developer | MetLogix™ | MetLogix™ | Metronics/Heidenhain | Metronics/Heidenhain |

*Available with either optical edge detection or video edge detection



HS600

SPECIFICATIONS

| HF750 | |
|-------------------|-----------------------|
| Horizontal Travel | 12" (300mm) |
| Vertical Travel | 8" (200mm) |
| Focus Travel | 3" (75mm) |
| Top Plate | 25 x 9" (635 x 230mm) |
| Image | Inverted and reversed |



FEATURES AND SPECIFICATIONS

- All metal construction with nickel plated stage tooling plate
- 24" (600mm) diameter screen with precision cross lines and overlay clips
- Motorized X and Y axes standard
- Two-axis power drive via joystick and variable speed control for fine adjustment
- Projection lens turret with four lens capacity (lenses not included)
- Turrent mounted condenser system and yellow/gree filter and provision to mount further accessories
- Stage Weight Capacity: 330lbs (150kg) (evenly distributed)
- Workstage Capacity Between Centers: 17.5" (440mm)
- Fully retractable duplex fiber optic surface illumination
- Halogen profile and surface illumination
- 0.001mm resolution Heidenhain linear scales
- Screen driven rotary Q-axis with 1' resolution
- Available with MetLogix™ M2 or M3 measuring software with touch screen and PC, or Quadra-Chek® digital readout systems
- Complete with full canopy and curtains

OPTIONS

- Six interchangeable lens magnifications including 10x, 20x, 25x, 31.25x, 50x and 100x
- Optional 5x fixed or 5x interchangeable on a 3-lens turret available by special order
- Interchangeable OV2 video camera system with 6.5:1 zoom lens
- Interchangeable TOV2 telecentric video camera systems with choice of 0.16x, 0.3x or 0.5x fixed magnification lenses
- Extended Stage Travel: 20" (500mm) X-axis; 8" (200mm) Y-axis
- Fully automatic CNC controls
- Automatic Optical Edge Detection
- Automatic Video Edge Detection available only with OV2 and TOV2 video camera systems
- Extensive line of accssories

HS600 DIMENSIONS

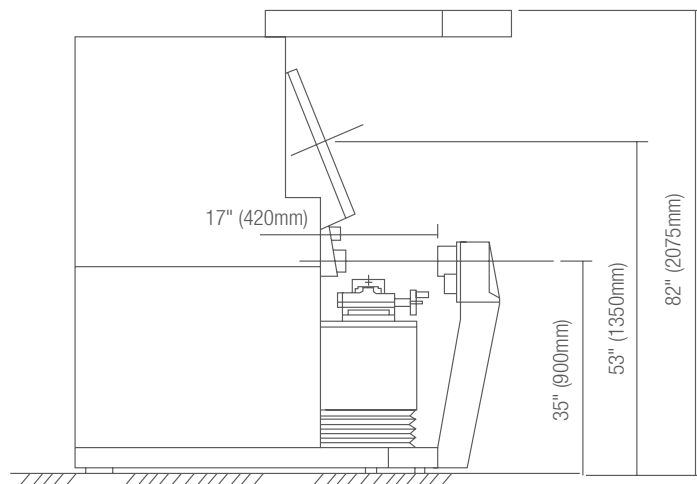
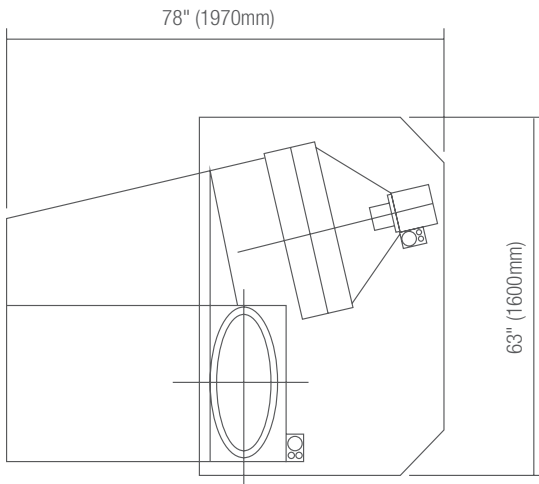

WEIGHT AND DIMENSIONS

| | HS600 |
|--------------------|------------------------------------|
| Net Weight | 2315lbs 1050kg |
| Shipping Weight | 2646lbs 1200kg |
| Dimensions (boxed) | 83 x 89 x 93" 210 x 255 x 235cm |



SIDE BED OPTICAL COMPARATORS

HS750

The HS750 floor-standing horizontal optical comparator has all the same features as the HF750 except that it has the screen position set to the side of the workstage area allowing close, comfortable and unrestricted access to the viewing and control area. At the heart of these systems are precision optics, superb lighting and a highly accurate workstage that combine to ensure bright, sharp images and exceptional accuracy. A time tested, cost-effective solution for non-contact measurement, the HS750 is simple to use, yet offers excellent capacity and performance to satisfy an exceptionally wide range of dimensional inspection applications and complex measuring requirements.

OPERATOR INTERFACE

| Feature | MetLogix™ | M3 | Quadra-Chek® | |
|-----------------------------------|-----------|-----------|----------------------|----------------------|
| | M2 | | QC221 | QC5200* |
| Mounted to comparator arm | x | x | x | |
| Color graphics | x | x | | x |
| Touch screen operation | x | x | | |
| Operating system | Windows® | Windows® | | |
| X-Y-Q axis digital readout | x | x | x | x |
| 2D geometry software with skew | x | x | x | x |
| Optical edge detection option | x | x | x | x |
| Video edge detection option | | x | | x |
| CAD file import and export option | | x | | |
| CNC drive option | x | x | x | x |
| Software developer | MetLogix™ | MetLogix™ | Metronics/Heidenhain | Metronics/Heidenhain |

*Available with either optical edge detection or video edge detection



HS750

SPECIFICATIONS

HF750

| | |
|-------------------|-----------------------|
| Horizontal Travel | 12" (300mm) |
| Vertical Travel | 8" (200mm) |
| Focus Travel | 3" (75mm) |
| Top Plate* | 25 x 9" (635 x 230mm) |
| Image | Inverted and reversed |

*With machined slots for easy fixturing



FEATURES AND SPECIFICATIONS

- All metal construction with nickel plated stage tooling plate
- 24" (600mm) diameter screen with precision cross lines and overlay clips
- Motorized X and Y axes standard
- Two-axis power drive via joystick and variable speed control for fine adjustment
- Projection lens turret with four lens capacity (lenses not included)
- Turret mounted condenser system and yellow/green filter and provision to mount further accessories
- Stage Weight Capacity: 330lbs (150kg) (evenly distributed)
- Workstage Capacity Between Centers: 17.5" (440mm)
- Fully retractable duplex fiber optic surface illumination
- Halogen profile and surface illumination
- 0.001mm resolution Heidenhain linear scales
- Screen driven rotary Q-axis with 1' resolution
- Available with MetLogix™ M2 or M3 measuring software with touch screen PC, or Quadra-Check® digital readout systems
- Complete with full canopy and curtains

OPTIONS

- Six interchangeable lens magnification including 10x, 20x, 25x, 31.25x, 50x and 100x
- Optional 5x fixed or 5x interchangeable on a 3-lens turret available by special order
- Interchangeable OV2 video camera system with 6.5:1 zoom lens
- Interchangeable TOV2 telecentric video camera systems with choice of 0.16x, 0.3x or 0.5x fixed magnification lenses
- Extended Stage Travel: 20" (500mm) X-axis; 8" (200mm) Y-axis
- Fully automatic CNC controls
- Automatic Optical Edge Detection
- Automatic Video Edge Detection available only with OV2 and TOV2 video camera systems
- Extensive line of accessories

HS750 DIMENSIONS

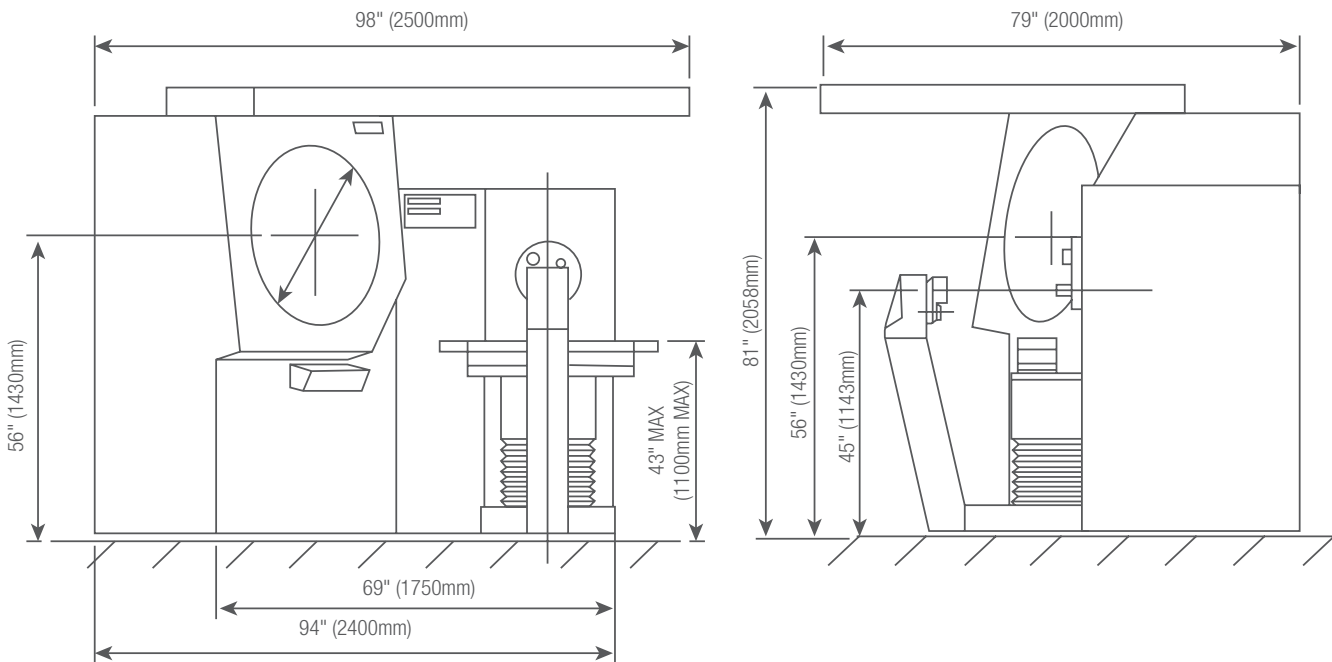

WEIGHT AND DIMENSIONS

| | HS750 |
|--------------------|-------------------------------------|
| Net Weight | 2932lbs 1330kg |
| Shipping Weight | 3307lbs 1500kg |
| Dimensions (boxed) | 119 x 94 x 91" 302 x 239 x 231cm |



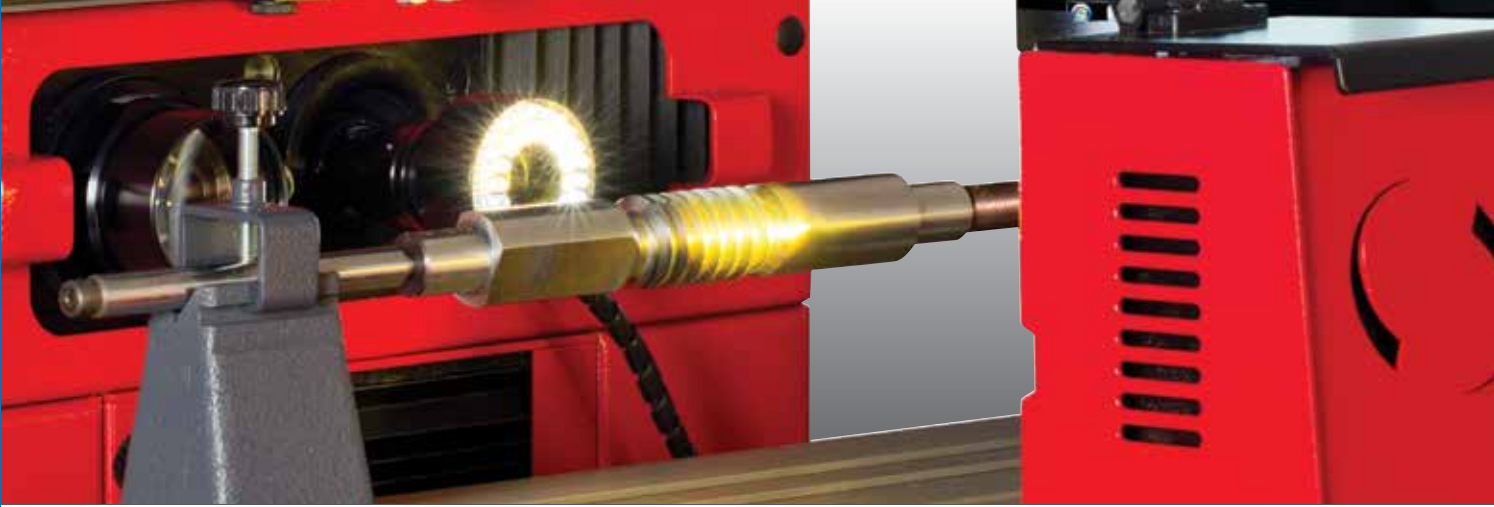

OV2™ OPTICAL COMPARATOR VIDEO ADAPTER

The OV2 is a special zoom lens and video camera adapter that can be interchanged with the fixed magnification lens on Starrett Optical Comparators. Combined with MetLogix™ M3 measuring software and touch-screen with PC, the result is a low cost video measuring system, expanding the versatility of your optical comparator! The OV2 is available as an option with new Starrett comparators and as an easy-to-install field retrofit. When used with the dual-lens HD400, and the HF600 and HF750 multi-lens turrets, the OV2 allows immediate access to both Video and Optical measurement without changing the part setup.

FEATURES AND SPECIFICATIONS

- Interchangeable bayonet style lens mount with 6.5:1 zoom lens, surface ring light and video camera creates a video measuring system
- Changeover between normal optical mode and OV2 is easy and fast
- Lens locks into comparator body and is pre-aligned
- Up to 1.25" (32mm) of working distance allows maximum stage travel utilization
- Video magnifications up to 240x
- Utilizes MetLogix™ M3 measuring software and touch-screen with PC for video display
- Maximizes existing investment to provide a low cost entry into video measurement technology
- Available for other makes of optical comparators, please call for more information



TOV2 OPTICAL COMPARATOR TELECENTRIC VIDEO ADAPTER

NEW!

The TOV2 telecentric lens and video camera can be interchanged with the fixed magnification lenses on Starrett Optical Comparators that utilize MetLogix™ M3 software. The TOV2 is available with a choice of 0.16x, 0.3x or 0.5x telecentric lenses as an option with new Starrett comparators and an easy-to-install field retrofit.

FEATURES AND SPECIFICATIONS

- Interchangeable bayonet-style lens mount with choice of 3 telecentric lenses, a surface ring light and video camera to create a video measuring system
- Offers a choice of .16x, .3x or .5x telecentric magnification lenses
- Changeover between normal optical mode and TOV2 is easy and fast
- Lens locks into comparator body and is pre-aligned
- Utilizes MetLogix™ M3 measuring software and a touch-screen with PC for video display
- Maximizes existing investment to provide a low cost entry into video measurement technology
- Available for other makes of optical comparators, please call for more information

OPTICAL COMPARATORS



M3 software display



SPECIFICATIONS AND OPTIONS

| Model | HE400 | HB400 | HD400 | VB300 | VB400 |
|--|---|---|---|--|---|
| Bench Top System | X | X | X | X | X |
| Floor-Standing System | - | - | - | - | - |
| Part View Orientation | Horizontal | Horizontal | Horizontal | Vertical | Vertical |
| Side Bed Version | - | - | - | - | - |
| Screen Diameter (in) | 16" | 16" | 16" | 12" | 16" |
| Screen Diameter (mm) | 400mm | 400mm | 400mm | 300mm | 400mm |
| X-Y Measuring Range (in) | 10 x 4" | 12" (16" optional) x 6" | 16 x 6" | 4 x 4" | 8 x 4" |
| X-Y Measuring Range (mm) | 250 x 100mm | 300 (400mm optional) x 150mm | 400 x 150mm | 100mm x 100mm | 200 x 100mm |
| Linear Glass Scale Encoder on X and Y Axis | Standard | Standard | Standard | Standard | Standard |
| Motorized X-Y Axis | - | Optional | Optional | - | - |
| CNC Control | - | Optional | Optional | - | - |
| Focus Range (in) | 1.2" | 2" | 2" | 3.5" | 4" |
| Focus Range (mm) | 30mm | 50mm | 50mm | 90mm | 100mm |
| Work Stage (in) | 18.75 x 4.75" | 21.25 x 5" | 21.25 x 5" | 8.8 x 8.8" | 16 x 19" |
| Work Stage (mm) | 475 x 120mm | 540 x 130mm | 540 x 130mm | 225mm x 225mm | 400 x 225mm |
| Load Capacity with Negligible Deflection (lbs) | 15lbs | 22lbs | 22lbs | 11lbs | 22lbs |
| Load Capacity Maximum (lbs) | 55lbs | 110lbs | 110lbs | 15lbs | 50lbs |
| Angular Measurement Resolution | 1' | 1' | 1' | 1' | 1' |
| Profile Illumination | Standard | Standard | Standard | Standard | Standard |
| Surface Illumination | Standard | Standard | Standard | Standard | Standard |
| Quick Change Lens Mount (lenses not included) | Single | Single | Dual | Single | Single |
| Collimating Condenser with Yellow/Green Filter | Standard | Standard | Standard | Standard | Standard |
| Control System Software | QC100, QC200, M1, M2 | QC100, QC200, QC5215, M1, M2, M3 | QC100, QC200, QC5215, M1, M2, M3 | LED Display, QC100, QC200, M1, M2 | QC100, QC200, M1, M2 |
| Display (control system dependent) | QC DRO, M1 tablet, 15" All-in-One touch screen PC | QC DRO, M1 tablet, 15" All-in-One touch screen PC, 24" touch screen monitor with PC | QC DRO, M1 tablet, 15" All-in-One touch screen PC, 24" touch screen monitor with PC | LED Display, QC DRO, M1 tablet, 15" All-in-One touch screen PC | QC DRO, M1 tablet, 15" All-in-One touch screen PC |
| Optical Edge Detection | Optional | Optional | Optional | Optional | Optional |
| Digital Video Camera System | - | Optional | Optional | - | - |
| Lenses - Screen Magnification (one required, not included) | 10x, 20x, 25x, 31.25x, 50x, 100x | 10x, 20x, 25x, 31.25x, 50x, 100x | 10x, 20x, 25x, 31.25x, 50x, 100x | 10x, 20x, 25x, 50x, 100x | 10x, 20x, 25x, 31.25x, 50x, 100x |
| Iris Diaphragm | Optional | Optional | Optional | - | - |
| Precision Rotary Vise | Optional | Optional | Optional | - | - |
| Vee Block on Rotary Base | Optional | Optional | Optional | - | - |
| Precision Fixed Vise | Optional | Optional | Optional | - | - |
| Precision Centers and Veers | Optional | Optional | Optional | Optional | Optional |
| Helix Center Support System | - | - | - | - | Optional |
| Precision Rotary Work Stage | - | - | - | - | Optional |
| Glass Plate Work Holder | Optional | Optional | Optional | - | - |
| Field of View Diameter (in) | 1.6, .8, .6, .5, .3, .15" | 1.6, .8, .6, .5, .3, .15" | 1.6, .8, .6, .5, .3, .15" | 1.6, .8, .6, .3" | 1.6, .8, .5, .3, .15" |
| Field of View Diameter (mm) | 40, 20, 16, 13, 8, 4mm | 40, 20, 16, 13, 8, 4mm | 40, 20, 16, 13, 8, 4mm | 40, 20, 16, 8mm | 40, 20, 16, 8, 4mm |
| Working Distance (in) | 3.1, 3, 2.5, 2.2, 2, 1.5" | 3.1, 3, 2.5, 2.2, 2, 1.5" | 3.1, 3, 2.5, 2.2, 2, 1.5" | 3.1, 3, 2.5, 2" | 3.1, 3, 2.5, 2, 1.5" |
| Working Distance (mm) | 80, 76, 62, 57, 50, 41mm | 80, 76, 62, 57, 50, 41mm | 80, 76, 62, 57, 50, 41mm | 80, 76, 62, 50mm | 80, 76, 62, 50, 41mm |
| Cabinet Stand 32" | Optional | Optional | Optional | Optional | Optional |
| Cabinet Stand 23" | Optional | Optional | Optional | Optional | Optional |
| Canopy and Curtains | Optional | Optional | Optional | Optional | Optional |



| VF600 | HF600 | HF750 | HS600 | HS750 |
|--|---|---|---|---|
| - | - | - | - | - |
| X | X | X | X | X |
| Horizontal | Horizontal | Horizontal | Horizontal | Horizontal |
| - | - | Standard | Standard | Standard |
| 24" | 30" | 24" | 30" | 30" |
| 600mm | 750mm | 600mm | 750mm | 750mm |
| 12" (20" optional) x 8" | 12" (20" optional) x 8" | 12" (20" optional) x 8" | 12" (20" optional) x 8" | 12" (20" optional) x 8" |
| 300 (500mm optional) x 200mm | 300 (500mm) x 200mm | 300 (500mm) x 200mm | 300 (500mm optional) x 200mm | 300 (500mm optional) x 200mm |
| Standard | Standard | Standard | Standard | Standard |
| Standard | Standard | Standard | Standard | Standard |
| - | Optional | Optional | Optional | Optional |
| 3" | 3" | 3" | 3" | 3" |
| 75mm | 75mm | 75mm | 75mm | 75mm |
| 25 x 9" (Optional 32" 8") 630 x 230mm | 25 x 9" (Optional 32" 8") 630 x 230mm | 25 x 9" (Optional 32" 8") 630 x 230mm | 25 x 9" (Optional 32 x 8") 630 x 230mm | 25 x 9" (Optional 32 x 8") 630 x 230mm |
| 110lbs | 110lbs | 110lbs | 110lbs | 110lbs |
| 330lbs | 330lbs | 330lbs | 330lbs | 330lbs |
| 1' | 1' | 1' | 1' | 1' |
| Standard | Standard | Standard | Standard | Standard |
| Standard | Standard | Standard | Standard | Standard |
| 4 Lens Turret | 3 Lens Turret | 4 Lens Turret | 3 Lens Turret | 3 Lens Turret |
| Standard | Standard | Standard | Standard | Standard |
| QC200, M2 | QC200, QC5215, M2, M3 | QC200, QC5215, M2, M3 | QC200, QC5215, M2, M3 | QC200, QC5200, M2, M3 |
| QC DRO, 15" All-in-One touch screen PC | QC DRO, 15" All-in-One, 21" touch screen PC, 24" touch screen monitor with PC | QC DRO, 15" All-in-One, 21" touch screen PC, 24" touch screen monitor with PC | QC DRO, 15" All-in-One, 21" touch screen PC, 24" touch screen monitor with PC | QC DRO, 15" All-in-One, 21" touch screen PC, 24" touch screen monitor with PC |
| Optional | Optional | Optional | Optional | Optional |
| - | Optional | Optional | Optional | Optional |
| 10x, 20x, 25x, 50x, 100x | 10x, 20x, 25x, 31.25x, 50x, 100x | 10x, 20x, 25x, 31.25x, 50x, 100x | 10x, 20x, 25x, 31.25x, 50x, 100x | 10x, 20x, 25x, 31.25x, 50x, 100x |
| Optional | Optional | Optional | Optional | Optional |
| - | Optional | Optional | Optional | Optional |
| - | Optional | Optional | Optional | Optional |
| - | Optional | Optional | Optional | Optional |
| Optional | Optional | Optional | Optional | Optional |
| Optional | - | - | - | - |
| Optional | - | - | - | - |
| - | Optional | Optional | Optional | Optional |
| 2.3, 1.2, .9, .5, .2" | 3, 1.5, 1.2, .6, .3" | 2.3, 1.2, .9, .5, .2" | 3, 1.5, 1.2, .6, .3" | 3, 1.5, 1.2, .6, .3" |
| 60, 30, 24, 12, 6mm | 75, 37.5, 30, 15, 7.5mm | 60, 30, 24, 12, 6mm | 75, 37.5, 30, 15, 7.5mm | 75, 37.5, 30, 15, 7.5mm |
| 5.4, 5, 4, 3.5, 1.7" | 6, 4, 3.6, 2.3, 1.9" | 5.4, 5, 4, 3.5, 1.7" | 6, 4, 3.6, 2.3, 1.9" | 6, 4, 3.6, 2.3, 1.9" |
| 138, 127, 103, 88, 44mm | 151, 101, 92, 60, 48mm | 138, 127, 103, 88, 44mm | 151, 101, 92, 60, 48mm | 151, 101, 92, 60, 48mm |
| - | - | - | - | - |
| - | - | - | - | - |
| Standard | Standard | Standard | Standard | Standard |



ACCESSORIES

Starrett offers a full range of accessories and purpose-built cabinet stands designed for our optical comparator systems to ensure efficient system setup for a broad range of applications.



| Photo Key | Part No. | Description | For Models |
|-----------|----------|---|---|
| A | OCN8 | Large Centers and Vees | HF600, HF750 |
| B | ORV2 | 2-1/32" Capacity Rotary Vise | |
| | 4U000 | | HE/HB/HD400 and VB400 |
| C | OGH1 | Magnification Checking Graticule | HF600 |
| | OGH2 | | HF750 |
| D | OCN7 | Small Centers and Vees | HF600, HF750 |
| E | 7P000 | Centers and Vees | HE/HB/HD400 |
| F | 9W000 | Helix Center Support Fixture | VB300, VB400, VF600 |
| | 3V000 | | |
| G | 6H000 | Centers and Vees | VB400, VF600 |
| H | OVH1 | Vertical Glass Plate Holder | HF600, HF750 |
| J | 7U000 | Vertical Glass Plate Holder | HE/HB/HD400 |
| K | 4H003 | Rotary Vise with 1-1/4" Capacity | HE/HB/HD400, HF600, HF750 |
| M | 6U003 | Rotary Work-stage | VB400, VF600 for use on 200mm x 100mm workstage |
| N | 4H002 | Fixed Position Vise with 1-1/4" Capacity | HE/HB/HD400, HF600, HF750 |
| P | 4H004 | Universal Vee Block on Rotary Base | |
| S | P-10095 | 32" Cabinet Stand | HE400, HB400, HD400, VB300, VB400 |
| | P-10102 | 23" Cabinet Stand | |
| T* | P-10485 | Canopy and Curtains designed to be used with Starrett cabinet stand | HE400, HB400, HD400, VB300, VB400 |

*Product not shown





SOFTWARE

METLOGIX™ SOFTWARE

M1, M2 AND M3

FOR OPTICAL COMPARATORS

Graphics rich display, large icon buttons, and intuitive operation. Coordinate display for X and Y linear axes and Q angular values for screen rotation. Easy part alignment and datum function.



M1 shown on HE400



M2 shown

FEATURES

- Clean and simple touchscreen interface with large icon buttons and intuitive operation
- Graphics-rich display providing instant information on feature form, tolerances, and measurement data
- Coordinate display for X and Y linear axes and Q angular values for screen rotation
- Easy part alignment and datum functions
- Measure and tolerance these geometric features: point, line, angle, distance, radius, diameter
- As you measure, a part view is created in the feature view. Constructions between features such as distances and bolt hole pattern can be done by simple selections from the part view.
- For repetitive part measurement, create a part program that will visually guide operators through part measurement
- Optional optical edge detection provides better throughput and removes operator subjectivity
- Video edge detection option on M3 only
- Four different report forms can be printed or exported to Microsoft Excel, text files, or to an SPC program
- M2 and M3 utilize a Windows®-based operating system enables flexible data export and interface capability
- M1 utilizes an Android operating system and a Bluetooth® connection to the host Optical Comparator
- Fast, easy connection to printers and networks

M1, M2 AND M3

MetLogix™ control software provides a broad range of powerful, user-friendly functions on a compact, icon-based touchscreen interface in place of the traditional control.

| | MetLogix™ M1 | MetLogix™ M2 | MetLogix™ M3 |
|--|--------------|--------------|--------------|
| Mounted to comparator arm | x | x | |
| Color graphics | x | x | x |
| Touch-screen operation | x | x | x |
| Operating system | Android | Windows® | Windows® |
| X-Y-Q (angle) measurements | x | x | x |
| 2D geometry software with skew | x | x | x |
| Optical edge detection option | x | x | x |
| Video edge detection option | | | x |
| CAD file import and export option | | x | x |
| CNC drive option | | x | x |



M3

FOR VISION SYSTEMS

Multi-touch software control that can pan and zoom with pinch, swipe, or touch. Works with active part views and live video feeds (or use the conventional mouse interface). Custom "Eye Measure" probe captures complex edges generated by a finger path drawn on the touch screen. Measure Logic probe intelligence provides instant feature determination and measurement with a single touch.



Intuitive graphic menu



Display flexibility or export the measurement report

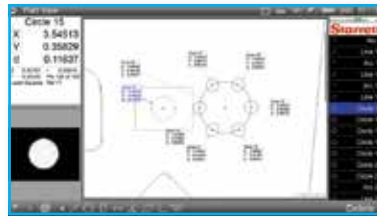

Graphic window with selectable Features and notes



Graphical window with the selected data points

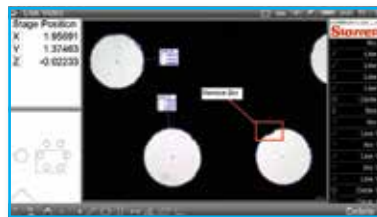

Live video image with data from selected points

FEATURES

- DXF CAD file import for comparing parts being inspected to the actual design file; no need for cumbersome Mylar overlays
- "Vtouch" Probe has video touch probe functionality – just click for simple acquisition of points on a feature's edge
- Part View can generate distance and tangent lines from within the graphical part view. The "Gesture Menu" can be used for feature creation and manipulation tools.
- "Quick Annotate" allows data on several features to be displayed simultaneously with smart marquee feature selection
- Application of universal tolerance value entry according to feature resolution groupings
- Feature Detail Graphics: Individual feature views display point cloud distributions, nominal deviations, and tolerance results. Scroll through Actual, Nominal, Tolerance, Deviation and Data Fit Type information
- Simple machine/camera calibration with popular machine and video correction methods
- Windows®-based, globally recognized OS for flexible data exporting and interface with Windows® applications
- DC (FOV) software option



Software MetLogix™ M3 with touch touchscreen interface



QUADRA-CHEK[®] SOFTWARE

Modern metrology is a complex sequence of measuring, recording, analyzing and reporting dimensional data. The conceptual model underlying the Quadra-Chek[®] digital readout design organizes the work-flow to support operators at every stage of the measurement process.

QC100

- Perform 2 and 3 axis measurements at very high levels of precision and accuracy
- Measurements viewed on the front panel LCD can be transmitted to a PC over a standard serial port connection, or to a printer over a parallel or serial port



QC100

QC200

Metrology DRO requires a video monitor display and cross-hair generator in vision configuration. QC200 is a time-saving measurement tool with patented Measure Magic[®] technology. Ideal for measuring 2D features on Optical Comparators and Manual Vision Machines.

- Inch/metric conversion, toggle between incremental/absolute and simple zero reset
- Skew function for ease of part alignment
- Integrated geometric tolerancing allowing for pass/fail measurements
- Simple part programming with measure guide
- USB and RS232 Interface
- Linear and segmented linear error correction
- Intuitive displays
- Crisp, clear, bright black and white LCD display
- Optional optical edge for comparators



QC200



QC5200

Metrology software utilizes a Windows® 64-bit operating system for video measuring machines.

The QC5200 supports a wide range of industries that require precise measurement and inspection of 2D parts using a single sensor. This product features an intuitive user interface and simple, meaningful visual displays. The design reflects a deep understanding of the user's needs along with a process model that supports the operator at every stage in the measurement process.

FEATURES

- 2D capabilities
- 2D part profiling
- Advanced calculation capabilities
- Advanced geometric tolerancing
- Alternate algorithms
- Auto-focus
- Auto program from CAD files
- Continuous edge mode
- CNC part positioning and automated measurement
- Customizable screen layouts
- Data cloud analysis
- Data export to wide variety of applications
- Image capture with drag and drop data reporting
- Integrated runs database
- Intuitive program editing capability
- Multiple reference frames
- Multiple language support
- Patented Measure Magic technology
- Powerful yet intuitive video edge detection tools

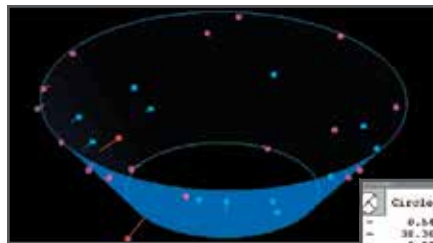

Data Cloud Alternate fits

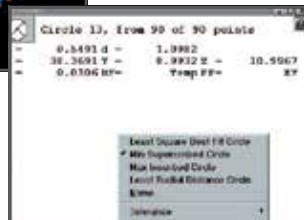
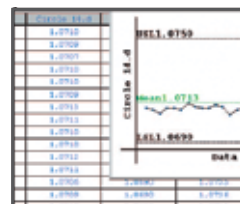

Image View

| MMC Tolerance Results | | | |
|-----------------------|---------|---------|---------|
| Position | Nominal | Actual | Error |
| X | 22.5620 | 22.5618 | |
| Y | 0.0708 | 0.0698 | 0.0009 |
| Z | 10.9466 | 10.9466 | |
| Size | Nominal | Actual | Deviate |
| Ø | 1.8660 | 1.8657 | -0.0003 |

Tolerance



Integrated Database

QC5300

Metrology software picks up where the QC5200 leaves off. This product offers multi-axis dimensional measurement of 2D and 3D parts. The QC5300 integrates an innovative user interface, state of the art ergonomics, powerful data import, export and data analysis tools.

FEATURES

- 3D capabilities
- 3D data clouds
- 3D measurement set
- 3D offset alignments
- 3D part view
- 3D part profiling option
- Image processing tools
- Pattern recognition
- Renishaw touch probe compatibility
- Optical laser sensor
- "X-Y" 2D measurements with optional "Z" Axis for height measurements
- Vector probing

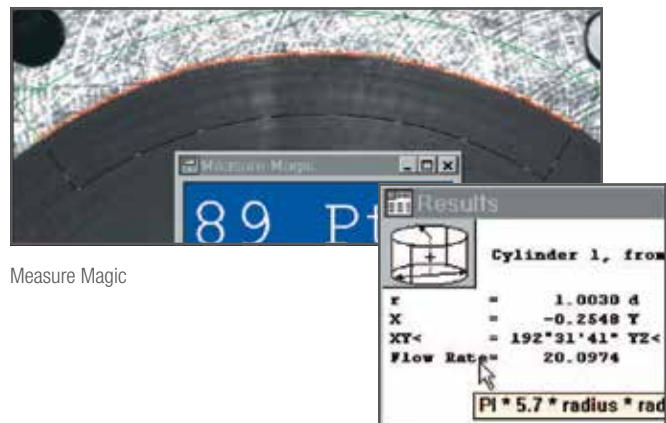

Measure Magic



Monitor not included



D1 INSPECTION SOFTWARE

FEATURES

- View and manipulate live and static images from a variety of inspection devices on any Windows® based operating system. Mouse/Keyboard and touchscreen systems are supported.
- A simplified operating interface requires only a few quick clicks to capture, mark up, export, print and email images directly from your inspection equipment
- Zoom and Pan the camera feed until the desired image is displayed. Add custom text, and graphic elements to generate detailed image capture for defect reporting and to improve overall visual communication of parts and component characteristics.
- Perform basic calculations of feature size, position, and orientation using a simple cross-hair tool. Translate or rotate the cross-hair tool within the image window to probe circle, line, point, and angle features within the field of view.
- Add feature annotation directly to selected features to display size, position and orientation results on either the video frame or within a blank part view space
- Access previously stored images easily in the thumbnail image list. Convenient date and time stamps are added to help sort and review collections of images.

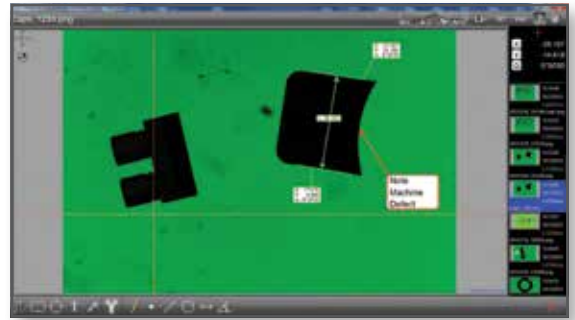
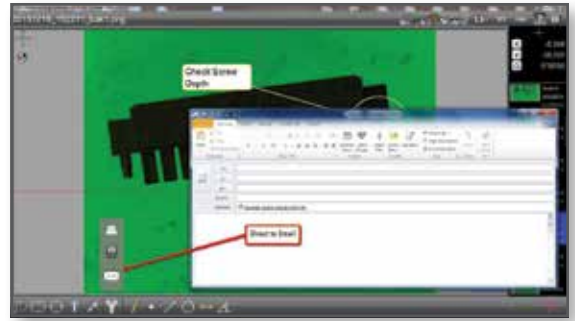

D1 Software display



KineMic - KMR with D1 software





**MATERIAL TESTING AND
FORCE MEASUREMENT**

SYSTEMS

L3 SYSTEMS

L3 Systems represent a new and easier solution for creating a test; performing a test; analyzing your test results; and managing test data.

L3 Systems meet the requirements of today's research scientist, design engineer, quality manager or technician responsible for material characterization, verification and validation.

Unlike traditional material testing systems that involve programming and having to know exactly what measurements are required before the test, L3 systems employ a simple methodology. You create your test method. Your test method creates your graph. And then you measure on the graph using a set of analysis tools.

You can measure any point and any segment anywhere along the graph. Analyze using stress, strain, load, distance, and time. Your measurements are displayed on your graph and shown in data tables with statistics and tolerances.

FEATURES

- Measure stress, strain, load, elongation, extension, and time results using tension, compression, flexural, cyclic, shear, and friction applications
- Create test setups using internationally accepted testing standards from ASTM, ISO, DIN, TAPPI and more, or create your own custom test methods
- Measure and calculate results graphically:
 - Points
 - Modulus, Slopes and Intercepts
 - Offset Yield
 - Min/Max/Avg
 - Breaks (Rate, %Drop)
 - Peaks and Valleys
 - Deltas
 - Rates
 - Hysteresis
 - Work/Energy
- Options for digital and analog I/O and Control Logic



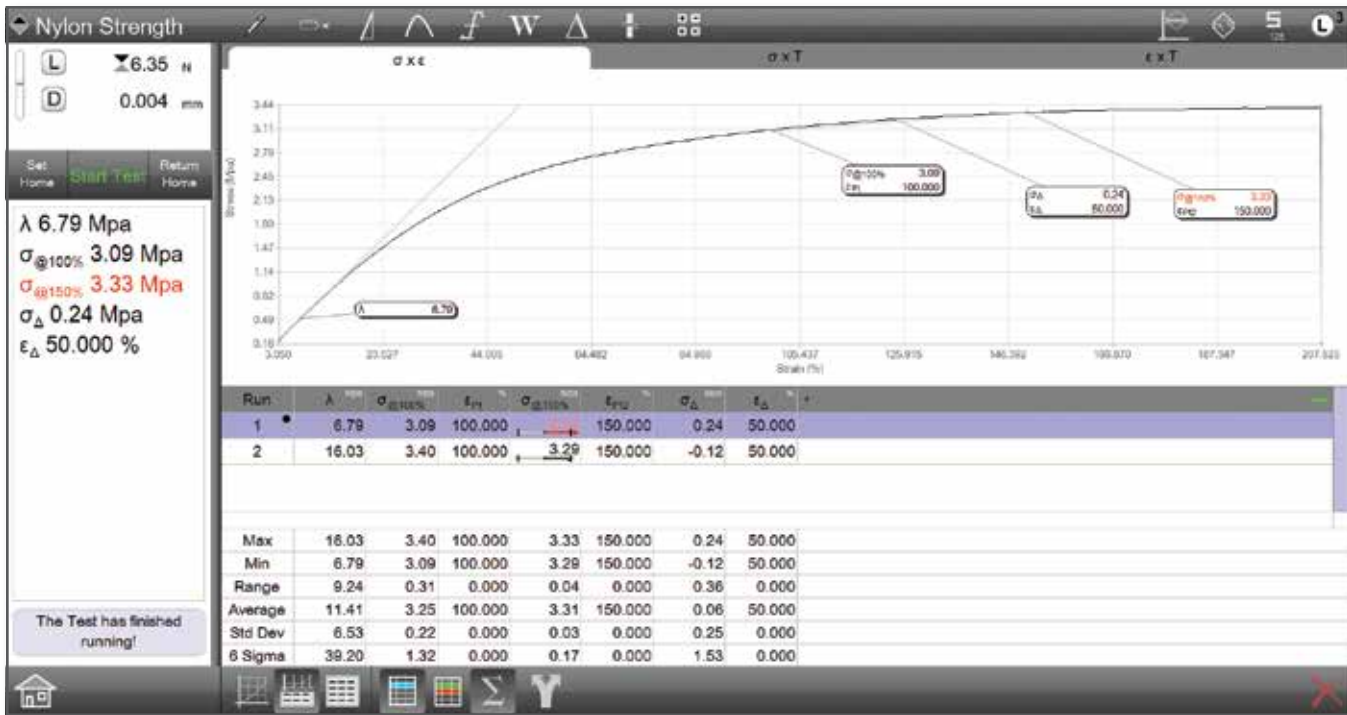

Measure results using SI or Imperial units of measure. Display results in Engineering Notation if needed. Specify resolutions for any unit type.

View results on any of these graph formats: Stress vs. Strain, Stress vs. Time, Strain vs. Time, Load vs. Displacement, Load vs. Time, Displacement vs. Time. Display full graphs or split graphs with the data table showing statistics and tolerance values.

(Above) Out-of-tolerance results are displayed in red, including a tendency bargraph in the data table.

Statistics can be displayed and your raw data and results can be exported automatically using the Share function.

(Below) The Tolerance view provides more detailed information as to "why" the result is displayed in red.

The operator can add comments about each test run, or use the Extra Coefficients function to display additional information for reporting. Standard reports are included, or export as a .csv file for use with Microsoft® Excel®, Word®, Access or your 3rd-party SPC application.

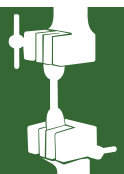
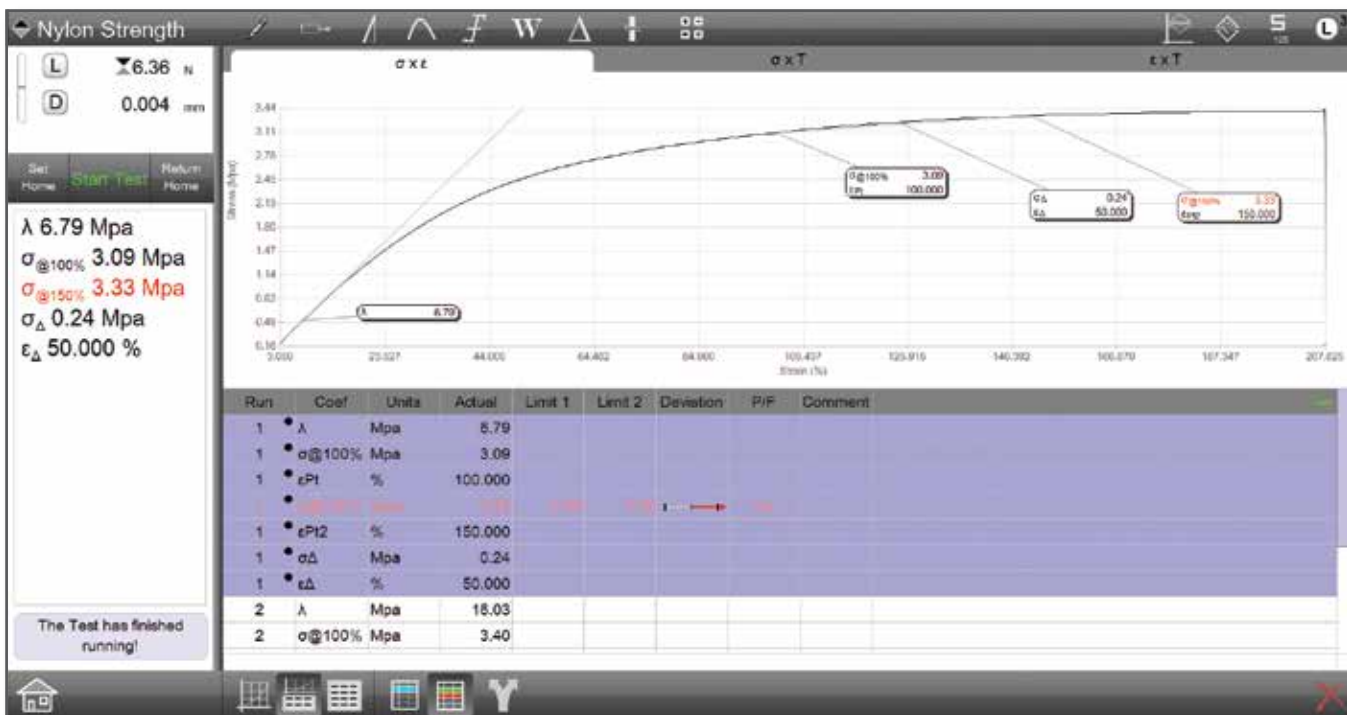

SYSTEMS

L3 SYSTEMS

Construct simple and complex multi-step test setups. Create your test method to an accepted standard or to your specific testing needs.

Create your test method and then email to other locations so that your testing is always performed in the exact same manner with the same measurements and results.

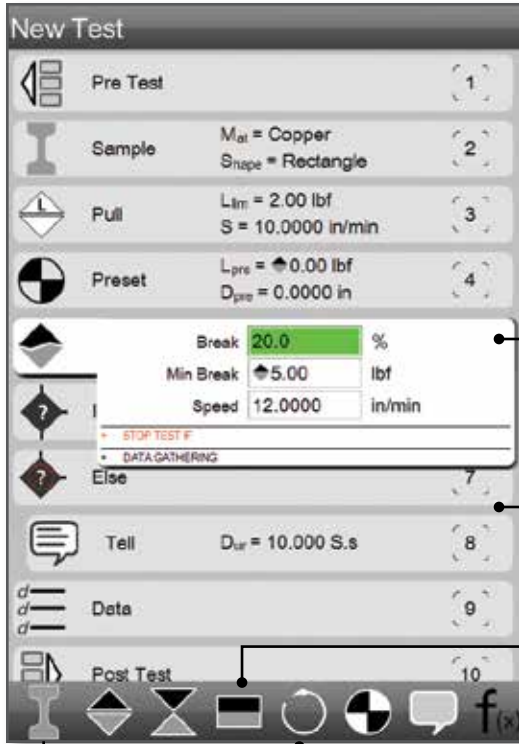

Tensile and Compression steps are used to perform "go to moves". Go to a Limit or Break at a velocity or load rate. You can choose exceptions for any move and decide whether to collect data during the move.

Shown is an operator prompt based on a conditional branching state. If the measured result is "out-of-tolerance", a message is displayed alerting the operator. If the result is within the tolerance range, no message is displayed.

Hold steps are used for creep and relaxation testing. You can hold at a limit for a specified duration up to 24 hours, if necessary.

Cycle based on any of your steps in your test method. You may cycle up to 1000 times or for a duration of up to 24 hours at a sampling rate of 1Hz. Each test may have a maximum of 100,000 data points.

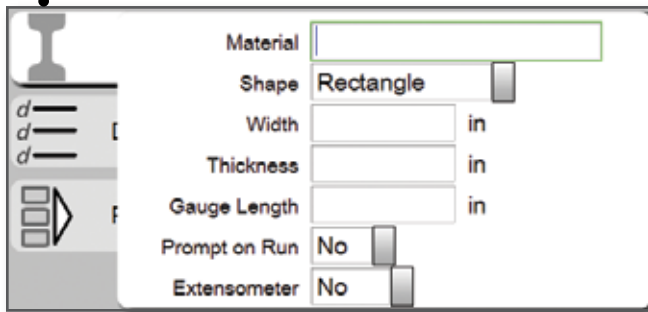

The Sample Definition step lets you name your material, specify the shape and its dimensions. You can enter dimensions digitally using a Starrett micrometer, or caliper.

Shown is the setup dialog for the optional I/O step. It allows you to control and activate external devices such as annunciators through the test frame's digital or analog I/O channels.

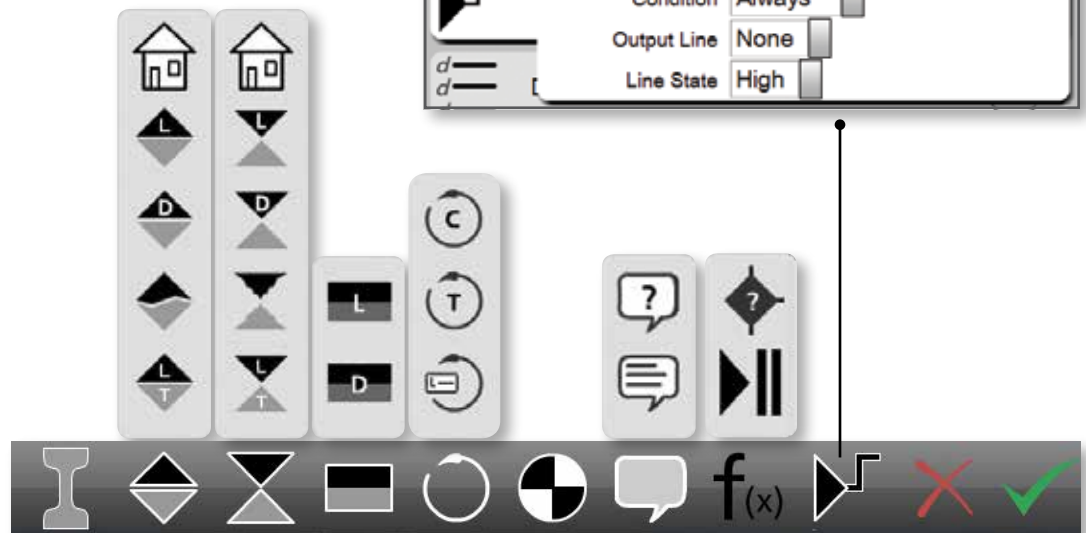
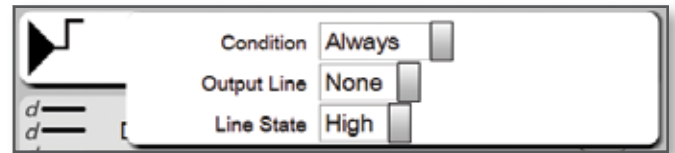

The Slope tool is used to find modulus. Multiple methods are available including automatic, chord, tangent, and best fit.

The Delta tool measures the differences between results. You can find creep by simply choosing this tool and the two points you want to compare.

Use the Annotation tool to add notes to any graph view.

Use the Min/Max/Avg tool to find maximum and minimum values. It can also be used to calculate averages of all data between a segment you specify.

You can compare multiple graphs of your test runs and measure delta and variances between tests at precise points. Ideal for benchmark analysis.

Use the Offset Yield Point tool to measure any data point on any of the three graph views. The point may be implicit or may be derived based on another result. For example, you can find the point at 100mS before the point at 100% strain.

Use the Work tool to determine the energy or resilience from your stress-strain graph.

Use the Formula Builder to create custom expressions and derived results using algebraic, trigonometric and logarithms.

The Peak/Valley tool is ideal for peel and coefficient of friction testing. Measure the maximum, minimum, average and counts of peaks and valleys.

Find break results based on a percentage drop or based on a load rate decrease.

The Offset Yield Point tool is used to measure the yield strength at a 2% strain offset. Shown is modulus at 100% and 150% and the delta between these two measurements.

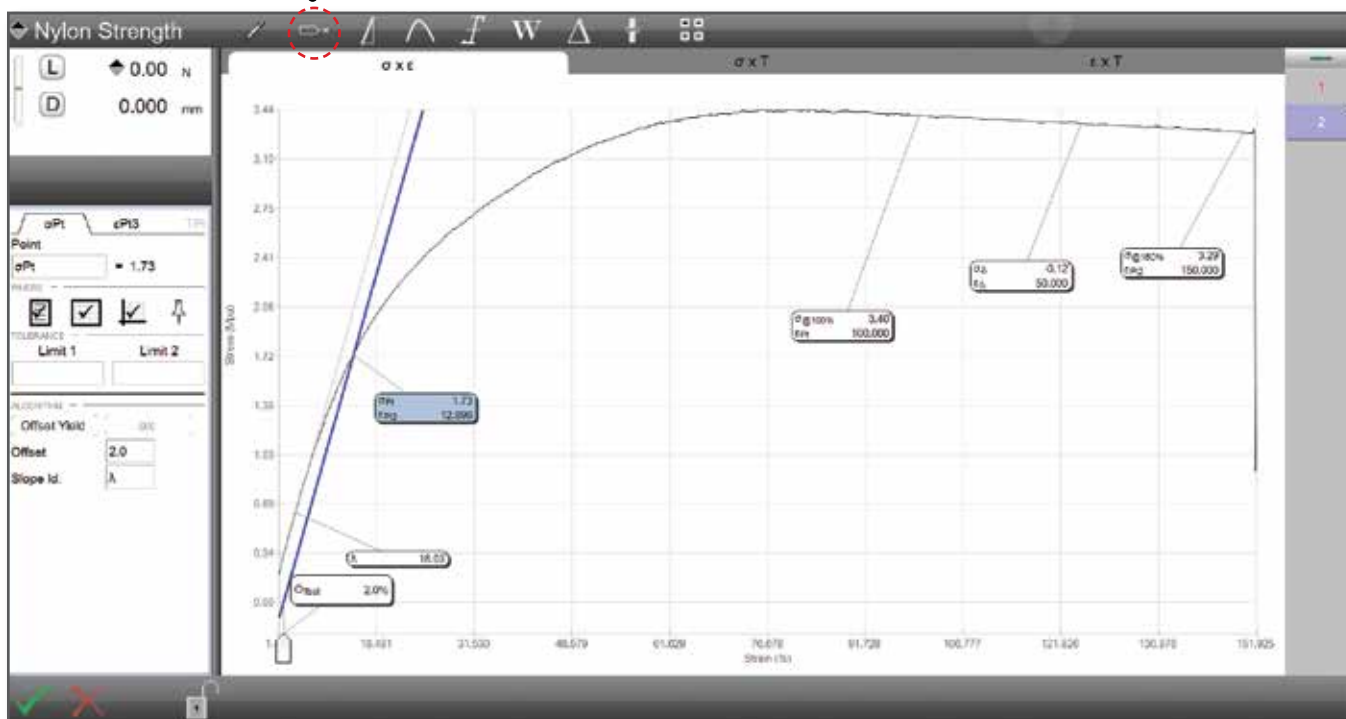

L2 PLUS SYSTEMS

Designed for advanced force measurement and analysis, L2 Plus Systems are optimized for quality and engineering personnel. Test setup is intuitive, efficient and non-compromising.

With L2 Plus systems you not only find the measurement, but you have the information that shows you "why, when and where" the measurement occurs.

Like our L3 systems, L2 Plus measurements and analysis are performed graphically using our Windows®-based, all-in-one computer workstation. Create high resolution graphs based on load, distance, height and time. Then measure any point or segment on your graph using a set of analysis tools.

FEATURES

- Ideal for tension, compression, rate control, flexural, cyclic, shear, and friction applications
- Measure and calculate results graphically:
 - Points
 - Slopes and Intercepts
 - Min/Max/Avg
 - Breaks
 - Peaks & Valleys
 - Deltas
 - Rates
 - Work/Energy
- Create test setups using internationally accepted testing standards from ASTM, ISO, DIN, TAPPI and more, or create your own custom test methods
- Options for digital and analog I/O and Control Logic
- Options for arithmetic, trigonometric and logarithmic calculations
- Use bar code scanning to access test setups

Perform advanced testing methods such as load rate control. Set a target limit then pull/push at a rate using load per time velocity.





Specific algorithms for peak & valley measurements are supported: find peak/valley, find maximum/minimum peak/valley, find averages for peaks/valleys.



Your results can be displayed in markers on your graph, in data tables, or in combinations. Graph types are: Load vs. Distance, Load vs. Time, and Distance vs. Time. Markers can display the load, distance and time to a specific point on the graph.

(Above) Use the Peak/Valley tool to locate the peaks for the entire test duration or for a defined segment within the test. per ASTM F88 Qualify your peaks and valleys using the sensitivity adjustment. Measure average, counts, maximum, minimum and more.

(Below) The load average is calculated for qualified peak values using a load sensitivity of 25%. Adjust for sensitivity using the data definition menu or by using the sensitivity adjustment bar on the y-axis. In this example, the load average is specified at a segment starting at the maximum load point (Lmax).

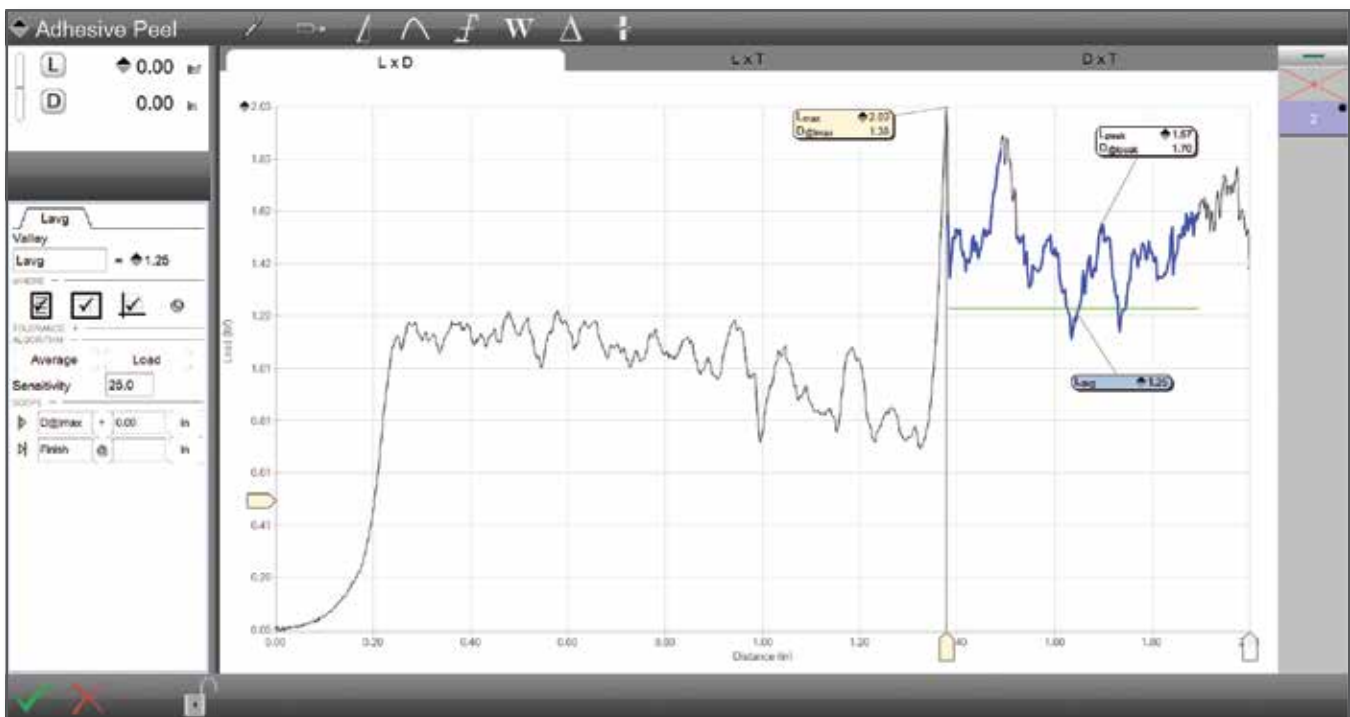

SYSTEMS

L2 PLUS SYSTEMS

Your test step can include "exceptions" which help with test flow control. If an exception occurs the test run can automatically abort. Your test data may be saved and exported, or you can choose to disregard the test altogether.

Here the test exceptions are "abort if the Load reaches 4.00lbf, or if the sample breaks after first measuring 2.00lbf".

Two forms of Break analysis are supported:
%Drop from Maximum Load and Rate.

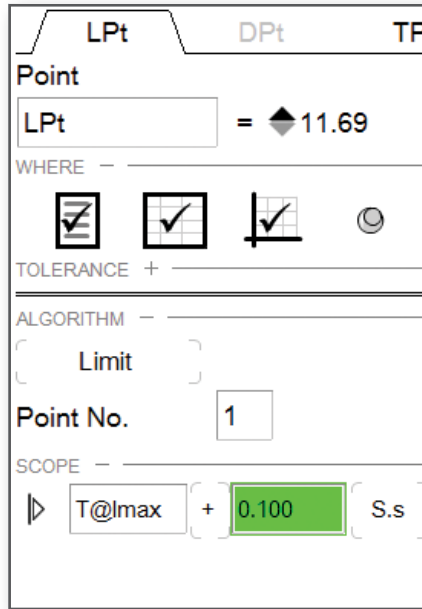
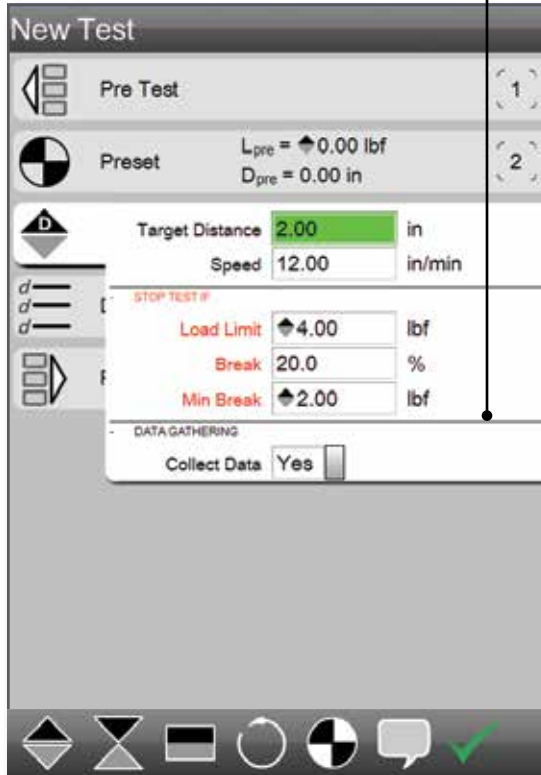

Scoping allows you to specify any point or segment of data from your graph for analysis. Measure based on load, distance and time.

Complex motion-control test steps may be performed, including load rate control. This test method lets you specify a load target and a velocity based on load rate. In this example, the target load is 15.00lbf and the test requires that you get to the target in 5 seconds, or a rate of 180.00 lbf/minute.

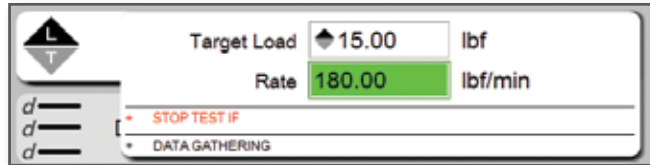

Make sure button is secured within test fixture

The Test has stopped because of an Exception
(press anywhere to continue)

System messages and prompts provide operators with alerts during testing. User prompts include ASK and TELL messages:

- ASK messages require an operator acknowledgement.
- TELL messages are displayed for a duration or until the operator acknowledges the message.

System messages display in red to alert the operator to alerts and warnings.



A bar code reader can be used to quickly load and launch your test setup. Ideal for busy, high-volume production applications where you are performing many test setups.

Measure these common results and more using your L2 Plus system:

- Absolute Peak
- Average Value (All Peaks)
- Average Value (Selected Peaks)
- Average Value (All Valleys)
- Average Value (Selected Valleys)
- Average Results (Regions)
- Break (Load)
- Break (Load/Extension Rate)
- Break (% Maximum)
- Coefficient of Friction
- Delta Creep
- Delta Relaxation
- Initial Peak
- Initial Valley
- Hold Preset Point
- Hysteresis Loss
- Slope Intersect
- Total Creep
- Total Relaxation
- User Calculations
- Work/Energy/Resilience



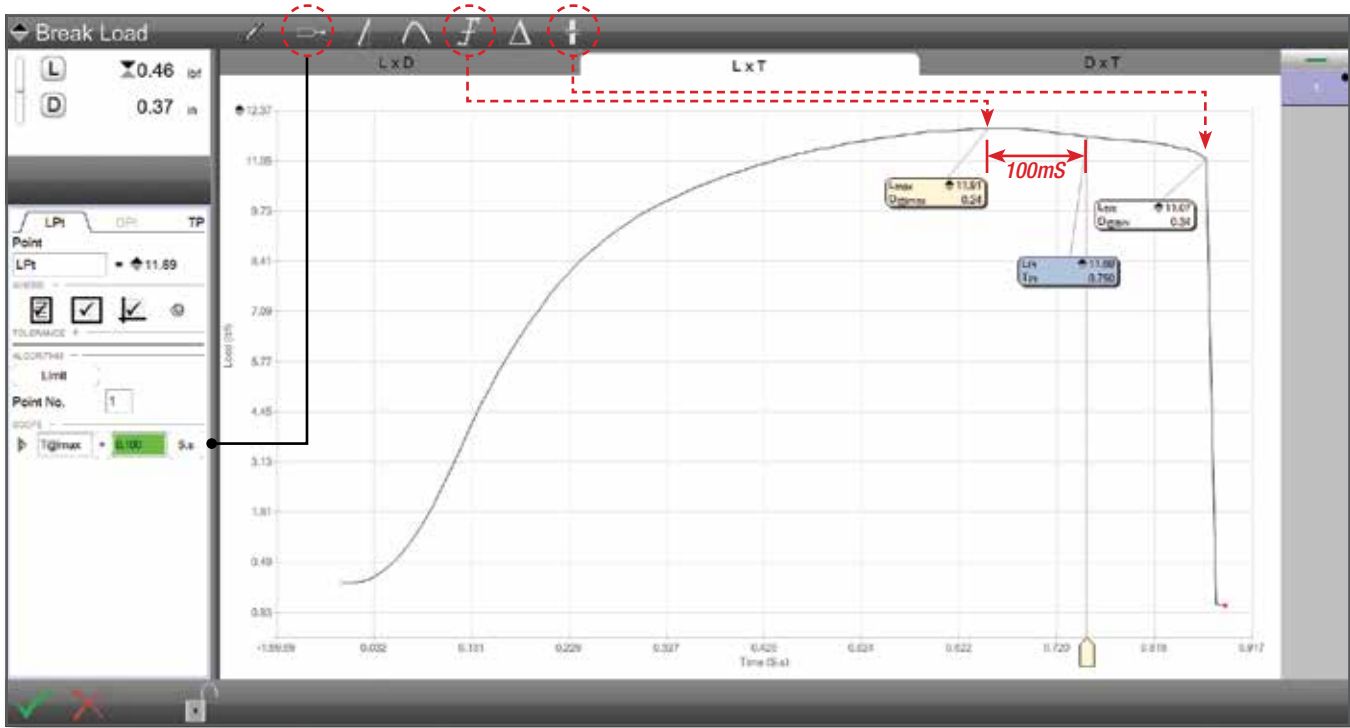

(Above) Anchoring is a scope feature. It allows you to easily measure from an existing result (anchor). In this example, the load value is found at 100mS after the maximum load (Lmax). In the scoping operation for the point result (Lpt), the Lmax is used as an anchored result. The "+" sign signifies "after" the anchored Lmax. The scope value is specified as time (S.s) and entered as 0.1 second. You can scope on load, distance or time.

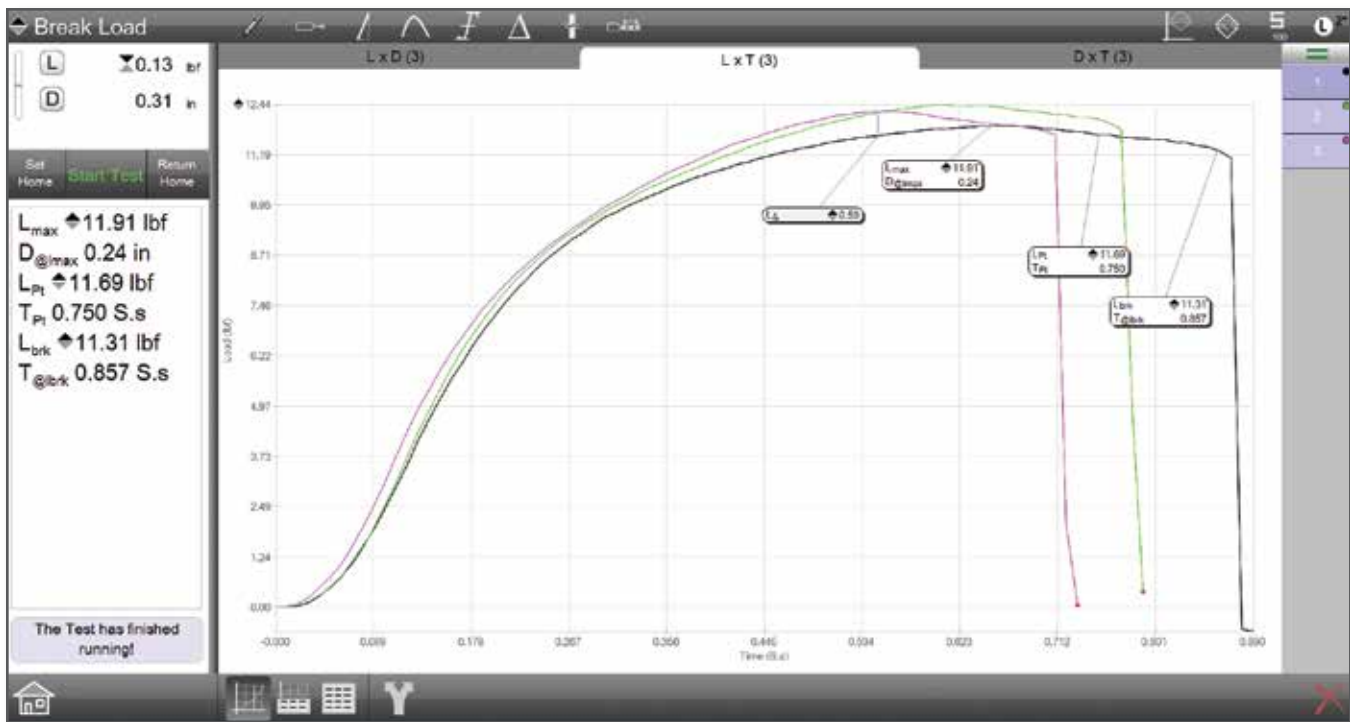

(Above) Using the "Multiview" function, you can measure using multiple graphs from your batch. Graph traces are overlaid onto one another and color-coded for identification. In this example, the delta variance is measured between the three test runs. The variance is measured at a point between the graph with the greatest value and the graph with the lowest value. This function can be used for "benchmark comparisons".



SYSTEMS

L2 SYSTEMS

Whether your application is high-volume in situ production, incoming inspection and validation, or just basic force measurement, the L2 System is an economical and easy-to-use solution.

L2 Systems feature a small footprint making them ideal for lean manufacturing environments. Create test setups in seconds using templates or create complex multi-stage test setups using the L2 Test Builder. No programming experience required.

L2 Systems operate using a Windows®-based tablet PC. Load, distance and time-based results are displayed in a large format for easy interpretation. Graphical representation of each test can be displayed. Data tables display results with tolerance and statistical calculations. Standard reports are included, or export data for use with other applications. System capacities range from 500N (112lbf) to 50kN (11,250lbf).

FEATURES

- Ideal for tension, compression, flexural, cyclic, shear, and friction applications
- Create test setups using internationally accepted testing standards from ASTM, ISO, DIN, TAPPI and more, or create your own custom test methods
- Measure and calculate results:
 - Min/Max/Avg
 - Breaks
- Options for digital I/O and Control Logic
- Options for arithmetic calculations

L2 systems can use any FMS, FMD, MMS or MMD test frame. Shown is an L2 system using an FMS-2500 test frame.



L2 Systems feature a tablet computer with touchscreen display. The system is WiFi®, Bluetooth® and USB compatible.

Perform common test methods such as determining maximum load, maximum deflection, average loads or how product reacts when a constant load is applied for a specified period of time.

L2 systems can determine break strengths and the sample's characteristics at load and extension limit values and provide you with immediate pass/fail indication.

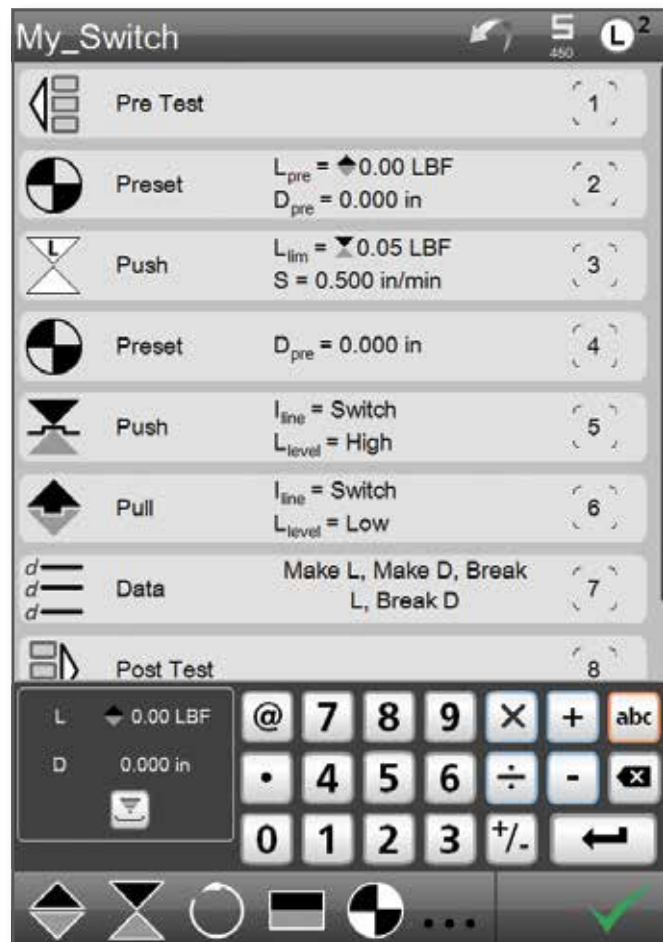
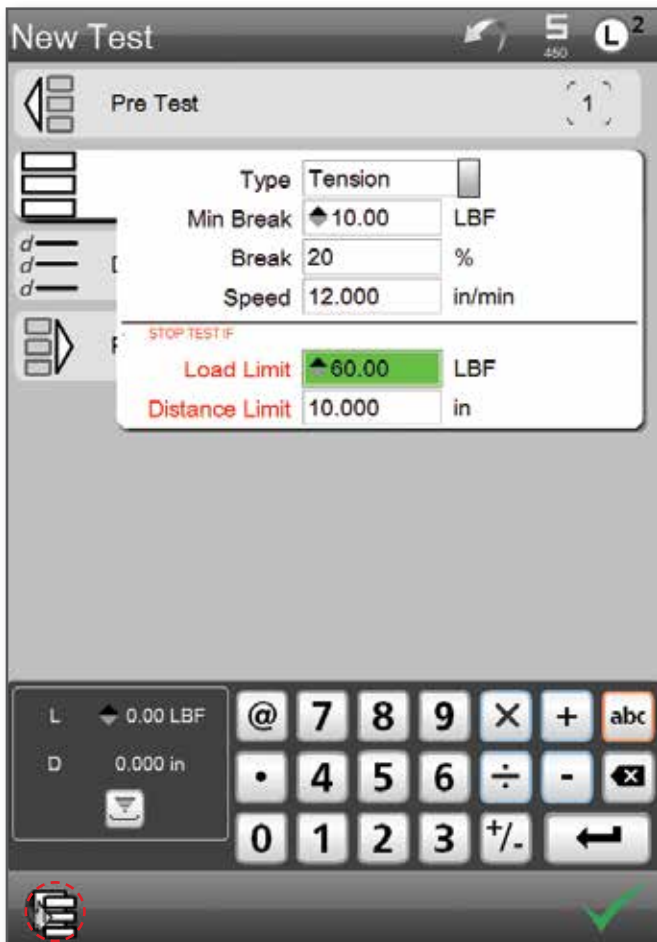

The L2 system includes test templates- pre-configured test setups for load, distance and break limit testing. These can be used to setup a test in seconds. Simply fill in the blanks and your setup is complete.

Use the Convert to Test Builder function and your test template is converted to a full Test Builder setup.

Use the Test Builder application supplied standard with L2 systems to construct simple and complex test setups. This example shows a contact closure test that also uses the optional Automation Builder and digital I/O. The Test Builder methodology is same across all Lx systems.



SYSTEMS

L2 SYSTEMS

Coefficient Settings L²

| | | |
|-----------------|--------|-----|
| Spring Rate | KSR | abc |
| Spring Constant | K | abc |
| Load | L | abc |
| Break Load | Lbreak | abc |
| Average Load | Lave | abc |
| Max Load | Mload | abc |
| Min Load | Lmin | abc |
| Delta Load | Ldelta | abc |
| Initial Tension | TIN | abc |
| Distance | D | abc |
| Dist at Break | Dbreak | abc |
| Max Distance | Mlen | abc |
| Min Distance | Dmin | abc |
| D at Max L | Dmaxd | abc |
| D at Min L | Dminl | abc |
| Delta Dist | Ddelta | abc |
| Free Length | FL | abc |
| Duration | Dur | abc |
| Speed | S | abc |

Done

Results, also called coefficients have default names. These can be changed using the Coefficient Settings function. You can rename a coefficient so that it is universally applied to all test setups.

Specialized functions, including deflection compensation or the ability to limit a load cell sensor are features to protect your instrumentation and to minimize operator errors. The Max Load Allowed feature can help prevent accidental load cell overloading.

Loads Settings L²

Export with minus sign Compression Disable Overload

Grip load LBF

Frame capacity LBF

Current load cell

Max load allowed %

Language Settings L²

- English
- český jazyk
- Deutsch
- Svenska
- Français
- Italiano
- Español
- Português
- Русский язык
- 繁體字
- 簡體字
- Język Polski

Done

File Locations L²

| Category | Location |
|----------|----------|
| Backups | Backups |
| Exports | Exports |
| Runs | Runs |
| Tests | Tests |

All Lx systems let you map where information is saved or exported to. Using the File Locations setting, you can specify how and where information is sent- automatically or on-demand. Test files, for example, can be created at a central location and then emailed to production facilities. This ensures that all manufacturing cells are using identical testing setups.

All Lx systems can display in multiple languages. A translation utility is included with all Lx systems. This allows custom translation to be performed so that dialect or specialized terms are universally applied to all displays.





The Results view can be configured to display the most critical result in large text.



The Statistics view displays the results and their associated statistical values. The header displays the total, passed and failed test runs. Failed runs display in red.

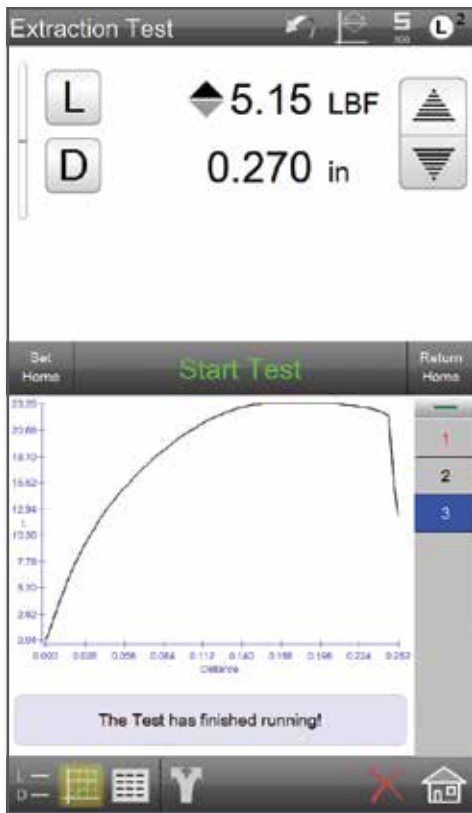

L2 systems display a graph profile. Unlike the L3 and L2 Plus systems, no measurement can be performed from the graph. Selecting the Graph symbol changes the graph axes. Graphs may be overlaid.

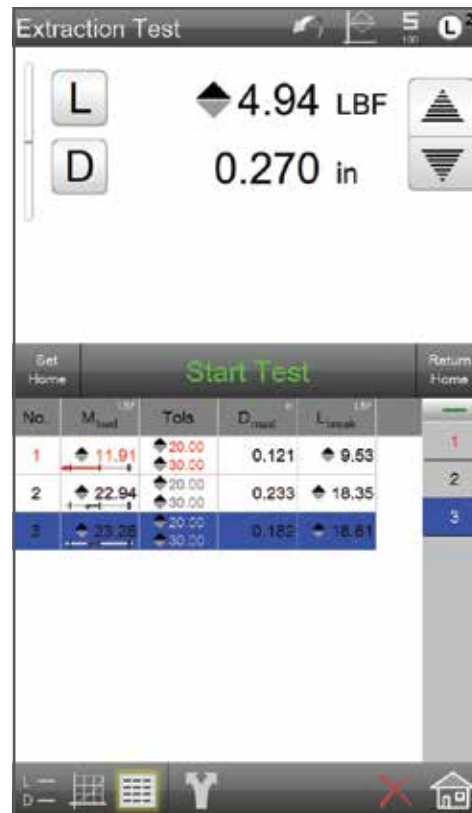

The Tolerance view shows the results and the tolerance limits. Test runs that are "out-of-tolerance" display in red with a tendency bar graph for analysis.



SYSTEMS

S2 SYSTEMS

When you need an easy-to-use measurement system for accurately and precisely determining spring rates, spring constants, spring lengths and other spring characteristics, S2 Systems are the solution. S2 Systems are ideal for high-volume production testing, quality control including incoming inspection verification and validation, and research and design engineering.

S2 Systems may be used for compression and extension springs with load ratings up to 11,000 lbf (50 kN, 5000 kgf). Our simple, fill-in-the-blank test setups let you test and validate your springs in as few as three steps allowing your testing to be performed in seconds. And your test results can be viewed, graphed and reported, including the ability to export results or raw data at rates up to 1000Hz.

TEST SETUP OPTIONS

Pre-Test Options

- Units of Measurement
- User Prompts to assist operator during testing
- Spring preconditioning (Scrag and Load Set Hold for duration)

Test Options

- Measure Free Length
- One Point Limit Test (Load or Height)
- Two Point Limit Test (Load and/or Height)
- Exceptions (Abort test if an exception is met)

Data Options

- Spring Constant (One Point)
- Spring Rate (Two Point)
- Date, User, Limit Setpoints

Post-Test Options

- Export Raw Data to a file location (up to 1000 samples/second)
- Export Results (Overwrite or Append data file)

Test Methods

- Spring Constant
- Spring Rate
- Initial Tension
- Free Length
- Load @ Height/Lengths
- Single Point
- Two Point
- Multiple Points
- Height/Length @ Loads
- Scragging and Load Hold Set



Perform one- and two-point testing to calculate spring constant and spring rate. Calculate free length and initial tension results for compression or extension springs. Load measurement accuracies to better than 0.1% are achieved using our IEEE 1451.4 compliant load cell sensors. Capacities range from 1N to 50kN (100 gf to 11,250 lbf).

Move to a position near the desired datum using the joystick and then press Up or Down. The stage will then move slowly in that direction until it can establish the datum.

0.000

Up Down

Cancel

An automatic datuming feature helps to ensure accurate height/extension/elongation measurements. Heights can be measured to 0.001 inch (0.025 mm).

Corrections

| | | |
|--------------------------------|-------|--------------------------|
| Enable LEC | No | <input type="checkbox"/> |
| Distance Standard | 0.000 | in |
| Distance Observed | 0.000 | in |
| Enable deflection compensation | No | <input type="checkbox"/> |
| Deflection Distance | 0.000 | in |
| Deflection Force | 0.00 | LBF |

The deflection compensation feature is ideal for compressive testing where mechanical deflection can adversely effect measurement accuracy and repeatability.



SYSTEMS

S2 SYSTEMS

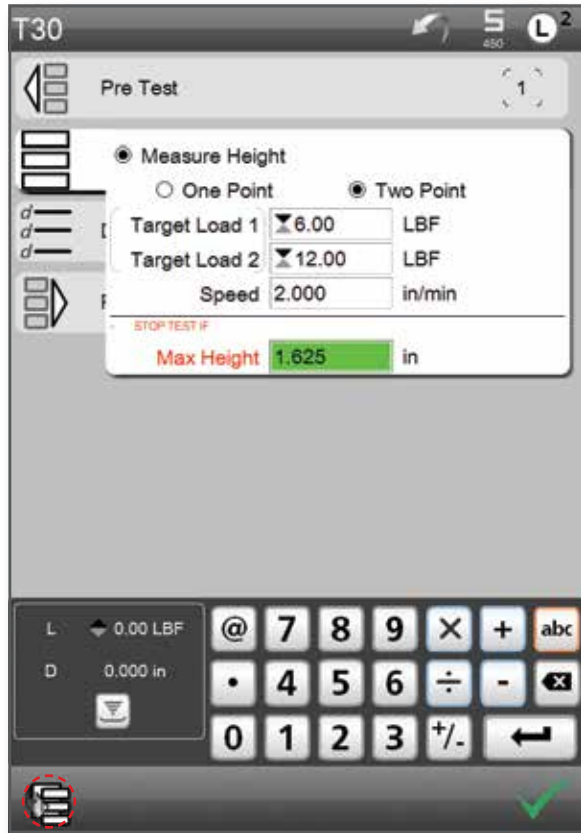

Create compression and extension tests using the test templates supplied standard with your S2 system. Or, use the optional Test Builder application to create sophisticated, multi-point test setups for more advanced spring measurement.

The optional S2 Automation Builder software works with the S2 Test Builder application so you can use conditional branching and digital I/O to interface with ancillary equipment such as annunciators, conveyors and turret loading devices.

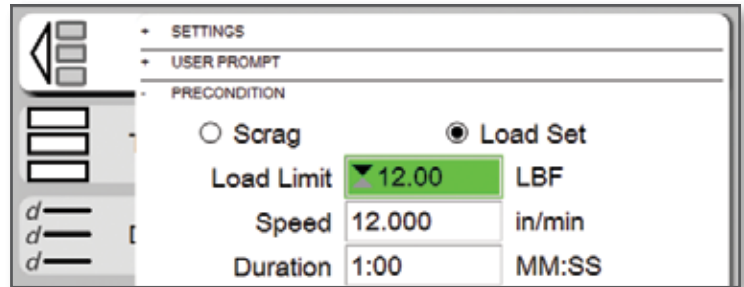
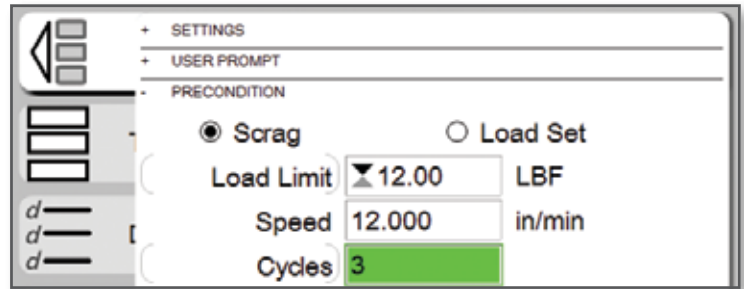

Preconditioning options include scragging and load set.

(Above) You can scrag your spring based on a number of cycles or based on a time duration.

(Below) Your spring may be set solid as a preconditioning prior to your actual test procedure. For example, compress to 12 lbf and hold for 1 minute.

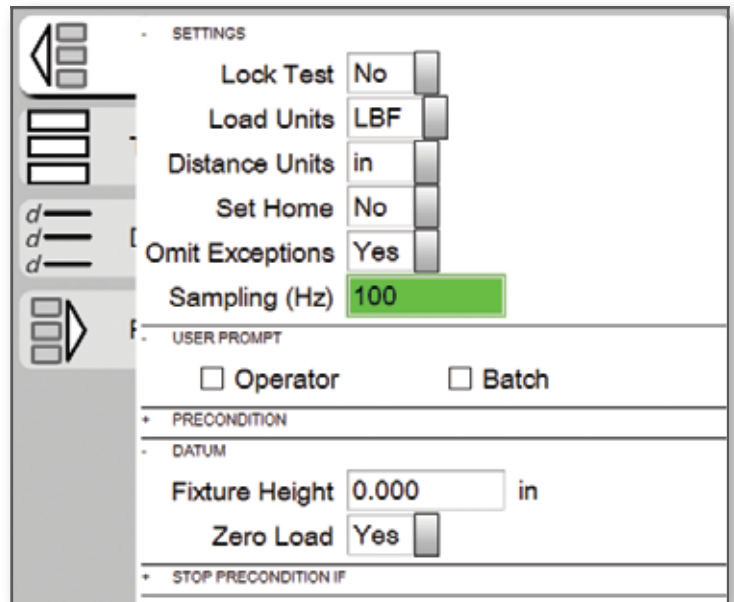

L

Hold Load

$D_{ur} = 1:00 \text{ MM:SS}$

5

0:16

The Pre Test step lets you specify test attributes before you actually begin your testing. Set units of measure, pre-conditioning, user prompts and datum criterion.



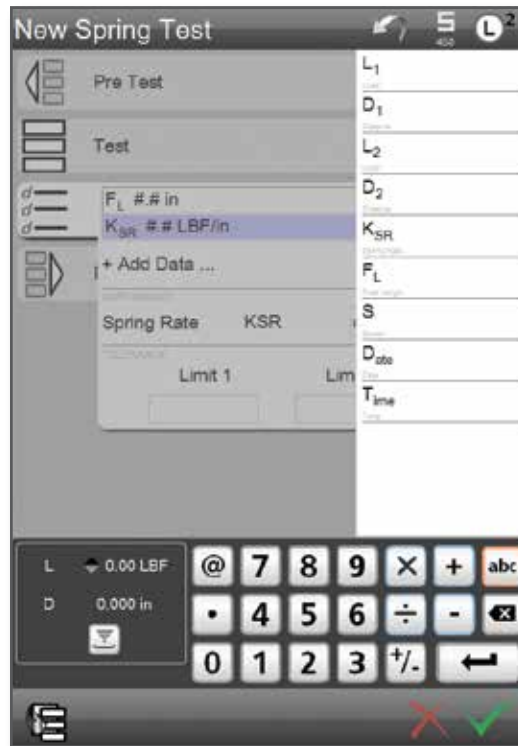
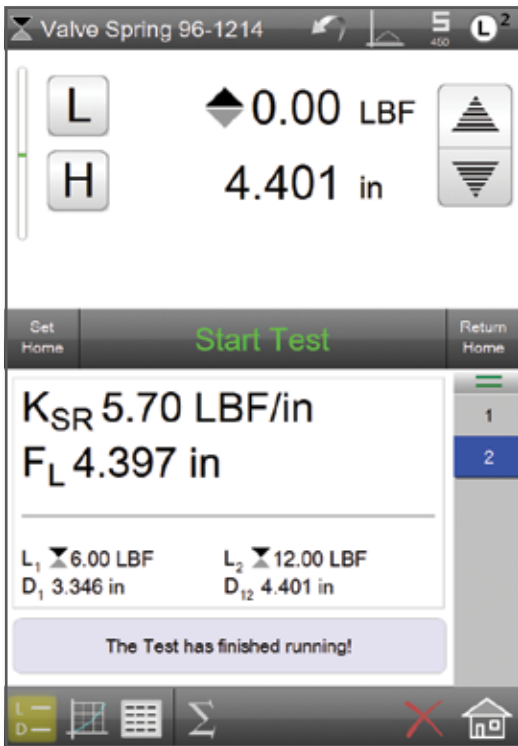

Upon completion of a test, you can display the key characteristics of your spring sample: Spring Rate, Free Length, and the individual measured results at your specified setpoint limits. The above display is for a 2-point compressive spring test.

Using the spring test setup templates, you can select the results you want using the Data step. A list of available standard results are displayed and you select the result you want and how it is to be formatted on your result view.

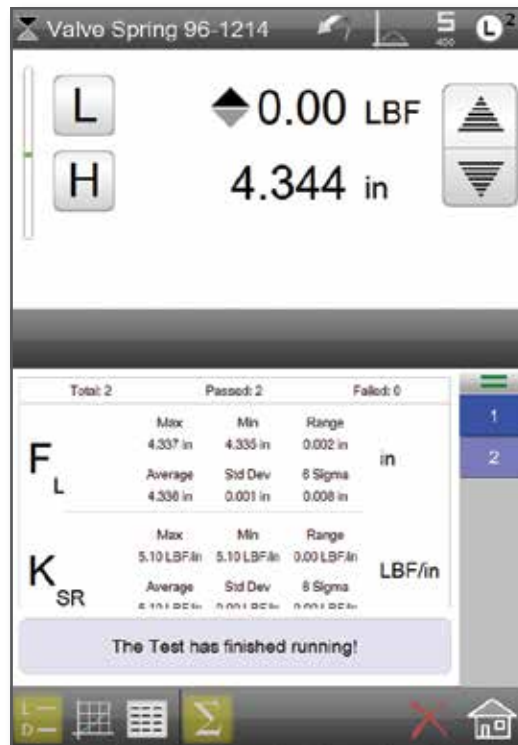
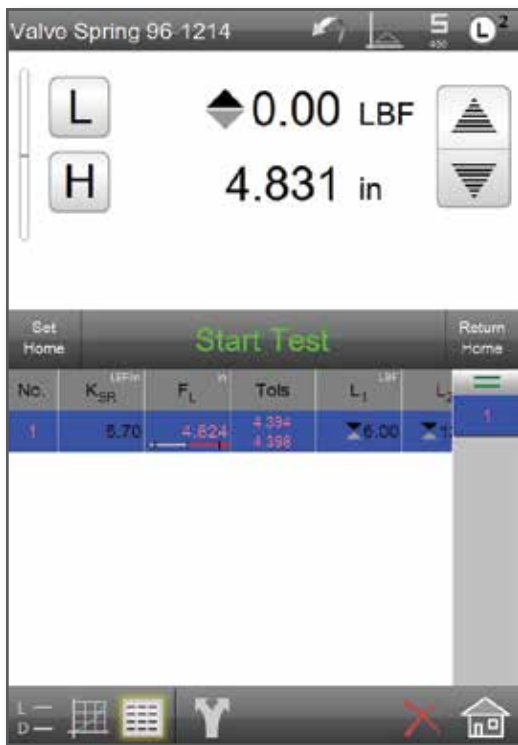

Like all Lx systems, within your S2 test, you may establish a tolerance on any result. Shown is an "out-of-tolerance" results for free length. The tolerance range is created between 4.394" and 4.398" in this example.

Your S2 software supports basic statistical process control. Individual results reported for your test can be compared statistically. You can view Mean, Min, Standard Deviation and Six Sigma for your selected results. When tolerance limits are used, you can summarize "pass and fail" results.

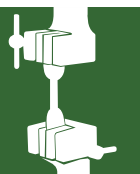

AUTOMATION

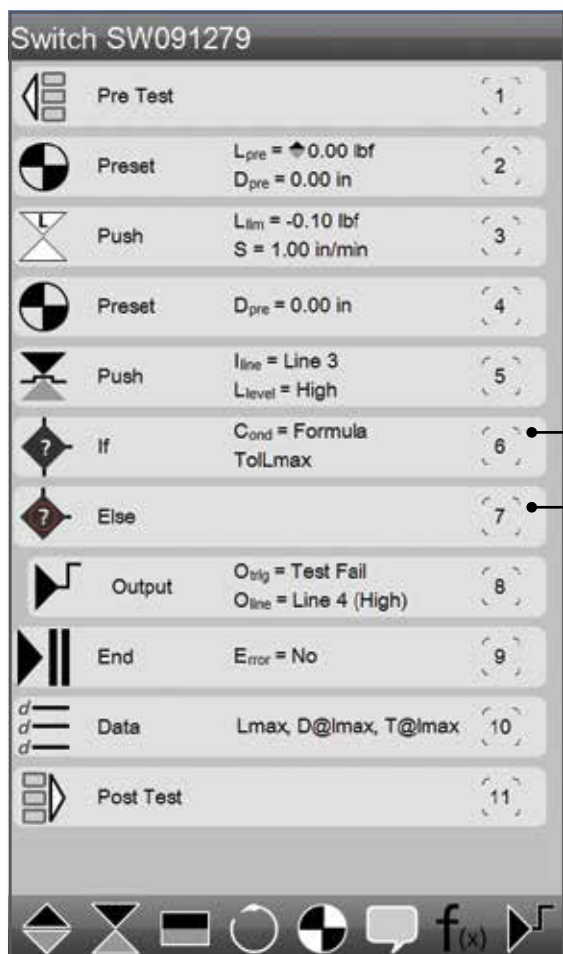

The Lx System can be interfaced with ancillary instrumentation for factory automation applications or where more advanced and complex measurements are necessary.

The optional Automation Builder software packages can be used for interfacing with instrumentation and equipment through digital and analog I/O signals.

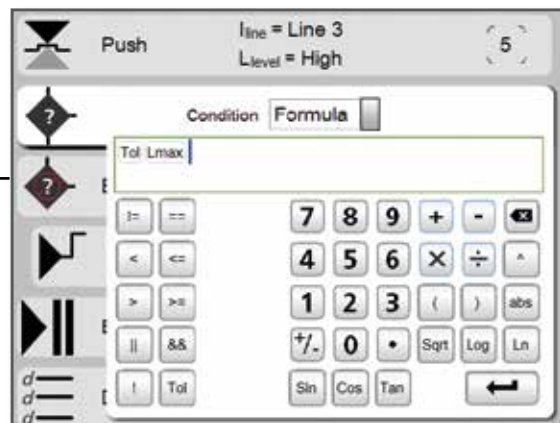

(Above) A conditional branching occurs when the Lmax result is out-of-tolerance. This will cause a message to display to the operator and it will cause a signal annunciator to light red for a failed test sample.

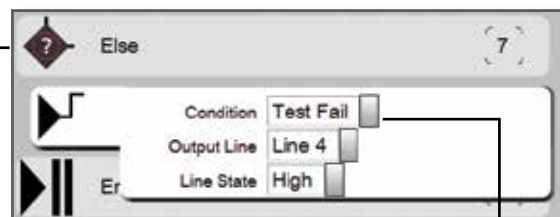

The Automation Builder can also be used to incorporate conditional logic within your test setup. Conditional logic can be used to establish If/Else relationships, including the ability to automatically adjust test setup functionality based on events that occur during a test run.

Digital I/O can be used for contact closure testing. You can measure and determine the precise load that caused the "make" or "break" in an electronic component or switch. You may also use conditional logic combined with the digital outputs to light an annunciator based on a tolerance result.



Digital I/O is available on all MMx and FMx test frames. Analog I/O is only available using the MMS or MMD test frames.



The Formula Builder allows you to construct complex, derived results using arithmetic, trigonometric and logarithmic expressions. The Formula Builder is standard in L3 systems and optional for L2 Plus, L2 and S2 systems. The Formula Builder for L2 and S2 systems supports basic arithmetic functions only- add, subtract, multiply and divide.

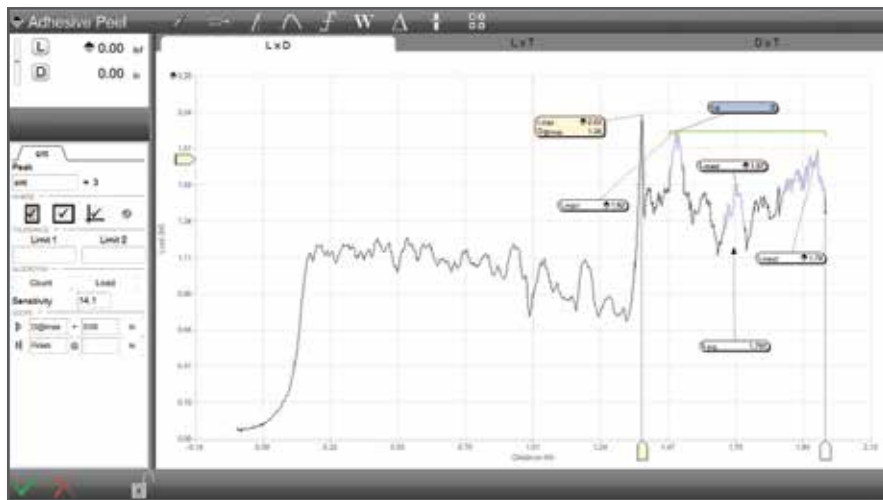

This example shows a full graph view of an adhesive test. Three peaks are identified based on the sensitivity of 14.1 after the Lmax (maximum peak).

The qualified peaks are highlighted in blue and identified as Lmax1, Lmax2 and Lmax3.

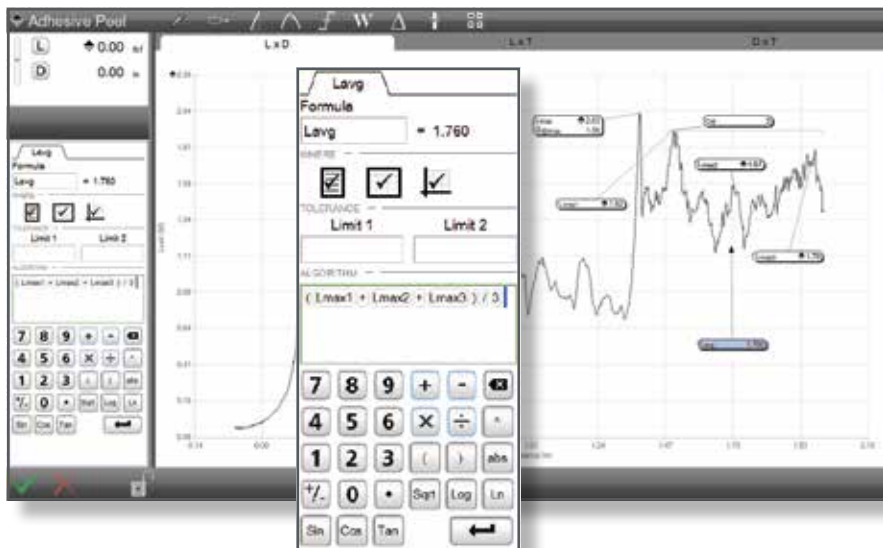

Using the Formula Builder, an expression was created that is an average of the three Lmax values only. The Lavg in this example application does not average all data points, but only the Lmax values.

The formula you create is evaluated real-time. Syntax errors are noted by displaying a red line around the formula input box. If the formula is correct, the line is green.

The functions and features available using the optional Automation Builder software are shown in the table.

The Formula Builder is supplied standard on L3 systems only.

Advanced mathematical expressions are not available with the Formula Builder in the L2 and S2 system's optional Automation Builder application.

| Automation Builder Software Option | | | | |
|--|------------------|---------|----|----|
| Measurement Capabilities | L3 | L2 Plus | L2 | S2 |
| Use Digital I/O | ○ | ○ | ○ | ○ |
| Use Analog I/O (requires MMx test frames) | ○ | ○ | ○ | ○ |
| Use Command and Conditional Logic | ○ | ○ | ○ | ○ |
| Formula Builder | | | | |
| Create Basic Expressions using Add, Subtract, Multiple and Divide | Std ¹ | ○ | ○ | ○ |
| Create Mathematical Expressions using Algebraic, Trigonometric and Logarithmic functions | Std ¹ | ○ | ○ | ○ |

Notes: (1) The Formula Builder function is supplied standard on L3 systems only. The Formula Builder is included in the optional Automation Builder software for L2 Plus, L2 and S2 systems. Advanced mathematical expressions using algebraic, trigonometric and logarithmic functions are available on L3 and L2 Plus systems only.

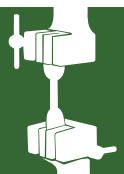

L1 SYSTEMS

Starrett L1 Systems represent our most-basic, computer-based force testing solution. Optimized for production and quality control testing, they are designed to be easy to setup, operate and maintain.

L1 Systems can be used to perform a wide variety of testing methods including:

- Load Limit Testing
- Distance Limit Testing
- Break Limit Testing
- Cyclic Count Testing
- Cyclic Duration Testing
- Constant Load Testing
- Constant Distance Testing

BASIC ARCHITECTURE

Your Starrett L1 System is comprised of the following:

- FMM Digital Force Tester
- Base clevis adapter kit
- USB 2.0 communication cable
- BLC Load Cell Sensor
- Load cell mounting block
- 2-in1 Windows® 10 Tablet Computer
- Table computer to column mounting fixture
- L1 Application Software

Communication between the hardware is USB 2.0.

The 2-in-1 L1 tablet features a 10", high-resolution, touchscreen, color display with three USB 2.0 ports.

The L1 application software lets you create your test methods quickly using test templates that guide you through the test setup process. Create common test methods in seconds.



L1-550 system with FMM-550 test frame and L1 tablet and software. Test fixture and BLC load cell sensor are optional.



L1 TEST TEMPLATES

The L1 System includes a set of common force measurement test templates. The templates have a common format consisting of these four test setup stages.

- Pre Test
- Test
- Data
- Post Test

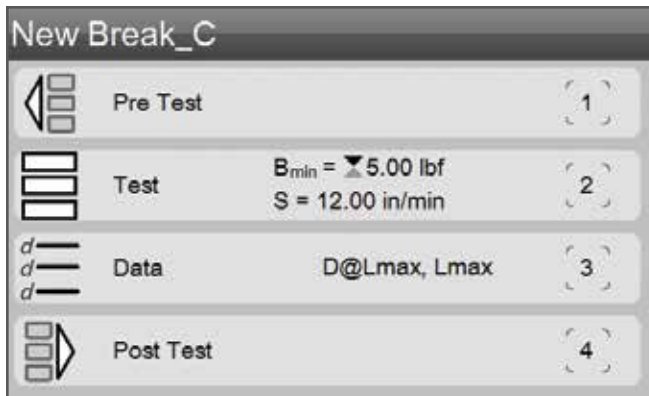

TEST SETUP ARCHITECTURE

All test setups include four common, easy-to-understand, menu-guided stages: Pre Test, Test, Data and Post Test.

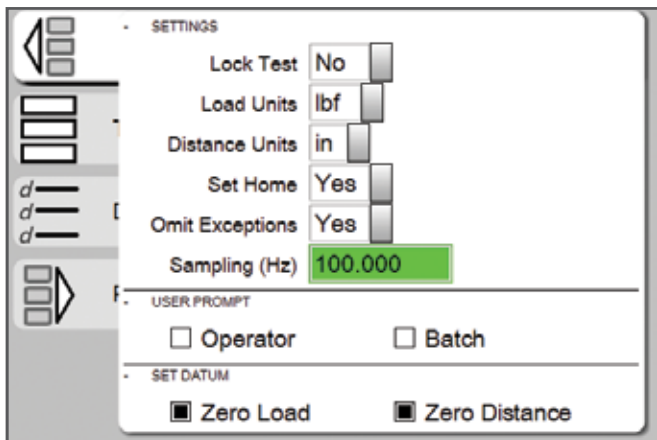

PRE TEST STAGE

The Pre Test stage supplies options you would perform prior to testing, for example, specifying the units needed to measure load and distance.

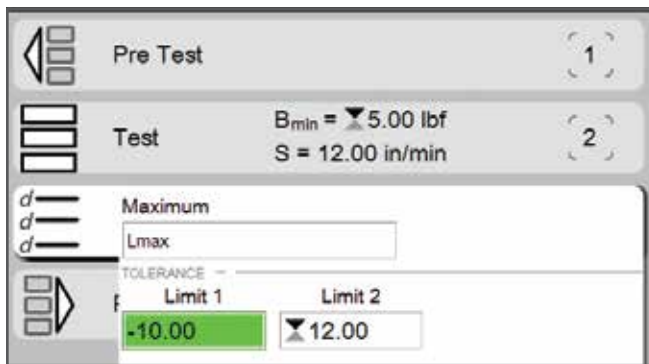

DATA STAGE

The Data stage is where you specify what results you want. For example, you can select Maximum Load, Distance @ Maximum Load, Distance @ Load Limit, Load @ Distance Limit and more. A list of values is displayed and you simply select the result you want. The Data stage is also where you can utilize tolerance limits for immediate "Pass/Fail" identification.

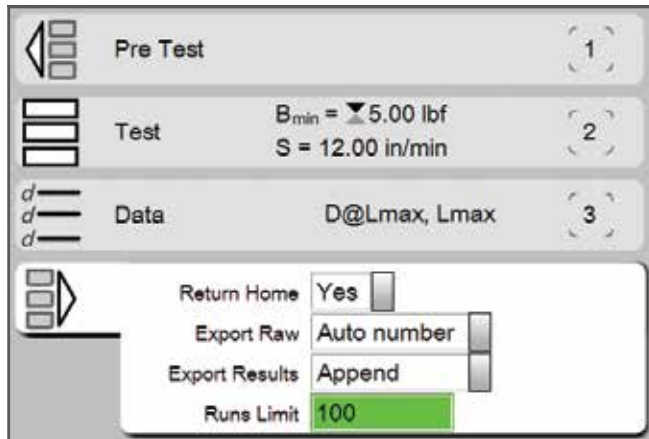
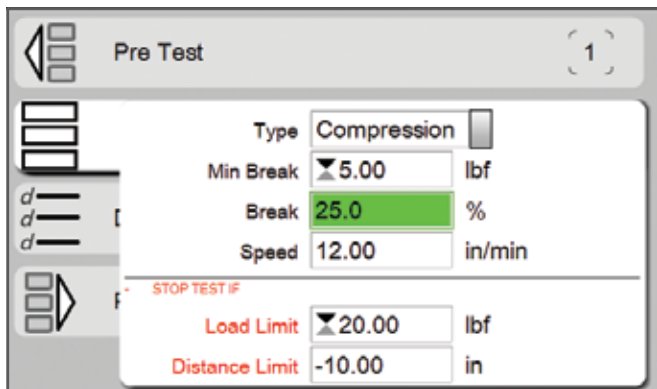

POST TEST STAGE

The Post Test stage lets you define what you want to do when the test concludes. You can export raw data or just the results and send to a network server. You can easily export directly to Microsoft® Excel® for custom report generation or analysis. Export information is saved as a .csv format for easy integration.

TEST STAGE

The Test stage is where you specify your testing requirements- what load you are using, what distance your crosshead will move, how fast your test speed is. Plus, you can easily add "exceptions". Exceptions are events that can be used to automatically stop your test, if they occur.



L1 SYSTEMS

When your L1 test method concludes, you can see the results you specified in your setup. Your L1 System will display results in these formats:

- Results View
- Graph View
- Data View
- Tolerance View
- Statistics View

RESULTS VIEW

Your results are displayed in a large, easy-to-read format organized for quick interpretation. The result and associated units of measure are displayed. During testing the active load and distance measurement is displayed. The crosshead speed and direction of travel is also displayed so the operator is aware of the current test status.

GRAPH VIEW

Load, Distance and Time can be used to view the data points used for your test. You may sample at rates up to 1000Hz and display your graph profile for your test. You can select a point on the graph and see the associated load, distance and time. You can also overlay multiple graphs to make graphical comparisons.

DATA VIEW

Results can be displayed in a tabular format. This is ideal for a quick comparison of each test in a batch of tests performed throughout the shift or day. You can export directly from the Data view to Microsoft® Excel®.

TOLERANCE VIEW

When tolerance limits are used for "Pass/Fail" analysis, you can see your tolerance limits compared to actual results. You also see "Pass" or "Fail". Failed results are displayed in red text. And we supply a deviation bar graph that shows where your results measured compared to your tolerance limits.

STATISTICS VIEW

Common statistics such as mean, maximum, minimum, standard deviation and six sigma may be displayed for all test results.

Your Test Name is displayed as well as the type of test: compression or tension.

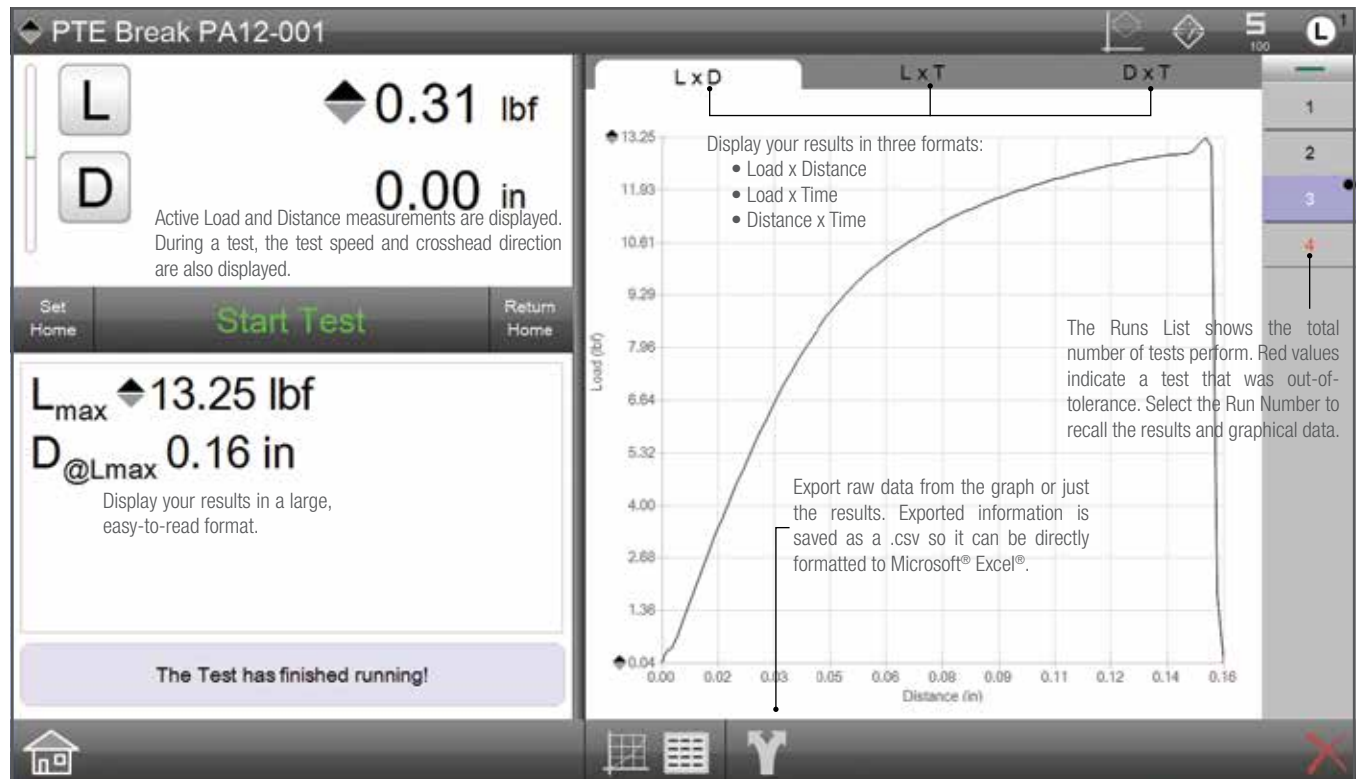

When the test concludes, your L1 software shows your results in numerical and graphical formats. Essential measurements are displayed an easy-to-interpret formats. You can Start and Stop a test using the touchscreen display; manually set the home position and return the crosshead to home position, an zero your load (L) and distance (D) measurements.





Compare the graphical results of multiple tests that you select. Individual graphs are color-coded and referenced to the test in the Runs List. You can also retrieve archived tests for making a graphical comparison. For example, you can compare a "benchmark" result from a year ago to a current result.

◆ PTE Break PA12-001

L 0.31 lbf
D 0.00 in

Start Test

L_{max} 15.65 lbf
D@L_{max} 4.35 in

The Test has finished running!

| Run | Coef | Units | Actual | Limit 1 | Limit 2 | Deviation | P/F |
|-----|--------|-------|--------|---------|---------|-----------|------|
| 1 | Lmax | lbf | 12.87 | 10.00 | 15.00 | ↔↔↔ | Pass |
| 1 | D@Lmax | in | 3.19 | | | | |
| 2 | Lmax | lbf | 12.97 | 10.00 | 15.00 | ↔↔↔ | Pass |
| 2 | D@Lmax | in | 3.10 | | | | |
| 3 | Lmax | lbf | 13.25 | 10.00 | 15.00 | ↔↔↔ | Pass |
| 3 | D@Lmax | in | 0.16 | | | | |
| 4 | D@Lmax | in | 4.35 | | | ↔↔↔ | Fail |

"Pass" and "Fail" status is immediate when using tolerances. Out-of-tolerance results are displayed in red.

Select the Data view and view results in a tabular format. Easily switch to Graph view by selecting the Graph symbol.

Display results in a tabular format complete with your tolerance limits. Test results that are out-of-tolerance are prominently displayed in red. Out-of-tolerance results are identified in the table, large results view and on the graph view in the Runs List. You can also display statistics on selected test runs. Calculate and display Minimum, Maximum, Mean and Standard Deviation with a single click.



SOFTWARE COMPARISONS

LX SYSTEMS

Lx System Product Comparisons and Capabilities

| Target Applications | L3 | L2 Plus | L2 | S2 | L1 |
|--|----|---------|----|----|----|
| Use for Stress, Strain and Material Testing applications | ○ | | | | |
| Use for Advanced Load, Distance and Force Analysis applications | ○ | ○ | | | |
| Use for Basic Load, Distance and Force Measurement applications | ○ | ○ | ○ | | ○ |
| Use for Advanced Extension and Compression Spring applications | ○ | ○ | | | |
| Use for Basic Extension and Compression Spring applications | | | | ○ | |
| User Interface | | | | | |
| All-In-On Computer Workstation, Windows® OS | ○ | ○ | | | |
| Tablet Computer, Windows® OS | | | ○ | ○ | ○ |
| Software Applications | | | | | |
| Test Builder | ○ | ○ | ○ | ✱ | |
| Force Quick Test Templates | | | ○ | | ○ |
| Spring Quick Test Templates | | | | ○ | |
| Formula Builder | ○ | ✱ | ✱ | ✱ | |
| Automation Builder | ✱ | ✱ | ✱ | ✱ | |
| Measurement Methodology | | | | | |
| Measure results using the graph | ○ | ○ | | | |
| Measure results using a List of Value menu | ○ | ○ | ○ | ○ | |
| Create Test Setups using Graphical Test Methods (No programming) | ○ | ○ | ○ | □ | |
| Create Test Setups using Quick-Test Templates | | | ○ | ○ | ○ |
| Test Methods | | | | | |
| Tensile Testing, Load, Distance, Break, Rate | ○ | ○ | ○ | □ | ○ |
| Compression Testing, Load, Distance, Break, Rate | ○ | ○ | ○ | □ | ○ |
| Hold Testing, Load, Distance for Duration or Event | ○ | ○ | ○ | □ | ○ |
| Cyclic Testing for Duration, Count, Loop or Event | ○ | ○ | ○ | □ | ○ |
| Shear Testing | ○ | ○ | | | |
| Flexural Testing | ○ | ○ | | | |
| Peel Testing | ○ | ○ | | | |
| Coefficient of Friction Testing | ○ | ○ | | | |
| Spring Testing | ○ | ○ | | ○ | |
| Measurement Capabilities | | | | | |
| Measure Stress, Strain, Elongation, Strengths | ○ | | | | |
| Measure Offset Yield | ○ | | | | |
| Measure Modulus (Elastic, Chord, Tangent) | ○ | | | | |
| Measure Strain and Elongation using Extensometer(s) (requires MMx test frames) | ○ | | | | |
| Measure Energy, Work, Resilience | ○ | ○ | | | |
| Create Mathematical Expressions using Algebraic, Trigonometric and Logarithmic functions | ○ | ▷ | | | |
| Create Basic Expressions using Add, Subtract, Multiple and Divide | ○ | ▷ | ▷ | ▷ | |
| Use Digital I/O | ▷ | ▷ | ▷ | ▷ | |
| Use Analog I/O (requires MMx test frames) | ▷ | ▷ | | | |
| Use Command and Conditional Logic | ▷ | ▷ | ▷ | ▷ | |
| Measure Load, Distance, Time | ○ | ○ | ○ | ○ | ○ |
| Measure Minimum, Maximum and Averages | ○ | ○ | ○ | ○ | ○ |
| Measure Slopes and Intersections | ○ | ○ | | | |
| Measure Peaks, Valleys, Counts, Averages | ○ | ○ | | | |
| Measure Break, Rupture | ○ | ○ | ○ | □ | ○ |
| Measure Delta between results within a test | ○ | ○ | ○ | | |
| Measure results within multiple test runs simultaneously (multiview) | ○ | ○ | | | |
| Measure Spring Rate, Spring Constant | ○ | ○ | | ○ | |
| Reporting and Exporting Data | | | | | |
| Print using standard reports, graph, batch, tolerance, statistics | ○ | ○ | ○ | ○ | ○ |
| Export results/data in .csv for custom reporting | ○ | ○ | ○ | ○ | ○ |
| Export results/data in .csv for integration with SPC software | ○ | ○ | ○ | ○ | ○ |
| Include tolerances on any result | ○ | ○ | ○ | ○ | ○ |

Note: FMM frames run L1 software only
L3, L2 Plus, L2 and S2 software require a FMS, MMS, FMD or MMD frame

- = Standard
- ✱ = Optional
- = Requires Test Builder application
- ▷ = Requires Automation Builder application

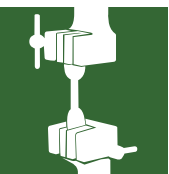

DIGITAL FORCE TESTERS

FMM DIGITAL FORCE TESTERS

FMM Digital Force Testers may be used with L1 software or with a Starrett DFC or DFG digital force gage. FMM digital force testers are compact and ideal for high-volume, lean manufacturing production.

FMM testers are available in three capacities: 110lbf (500N), 330lbf (1500N) and 550lbf (2500N). Two travel lengths are available for all capacities: standard travel at 20" (508mm) and extended travel at 30" (762mm). Crosshead speeds are controlled locally and can be set from 0.002 to 40 inch/min (0.05 to 1016mm/min). A high-resolution OLED display shows distance measurements with accuracy better than 20µm (0.0008 inch). Travel limits help prevent load sensor overloading.

The FMM force tester can be controlled using L1 software for limit, cycling, hold and coefficient of friction testing.

The FMM force tester can also be controlled using a DFC digital force gage. The DFC force gage serves as a universal controller where it is used to setup the force tester's distance limits, crosshead direction and crosshead velocity for a test.

FEATURES

- Ideal for tension, compression, flexural, cyclic, shear, and friction applications
- Use with L1 software and 2-in-1 tablet PC or with DFC and DFG force gages
- Multiple, Easy-to-Use Operating Modes
 - Manual
 - Automatic
 - Continuous
 - Gage Control (DFC force gage controls FMM tester)
 - Software Control (L1 system control)

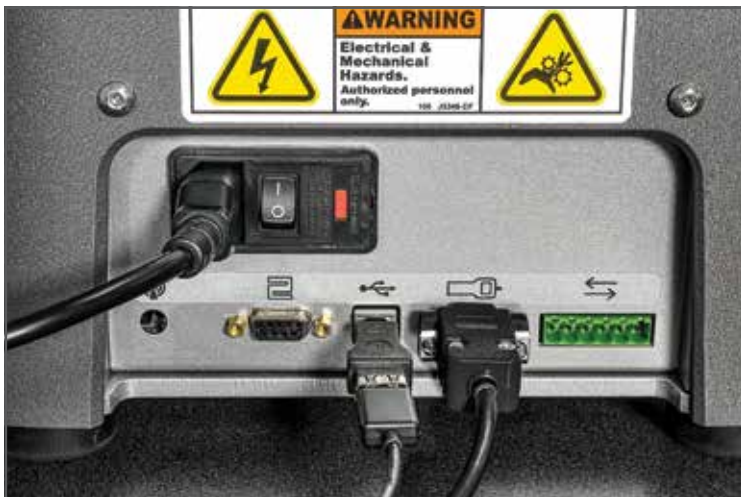

Interface connections and communications are clearly shown on the back panel.

Source power may be 100-240V- no jumpers required or configuration needed.

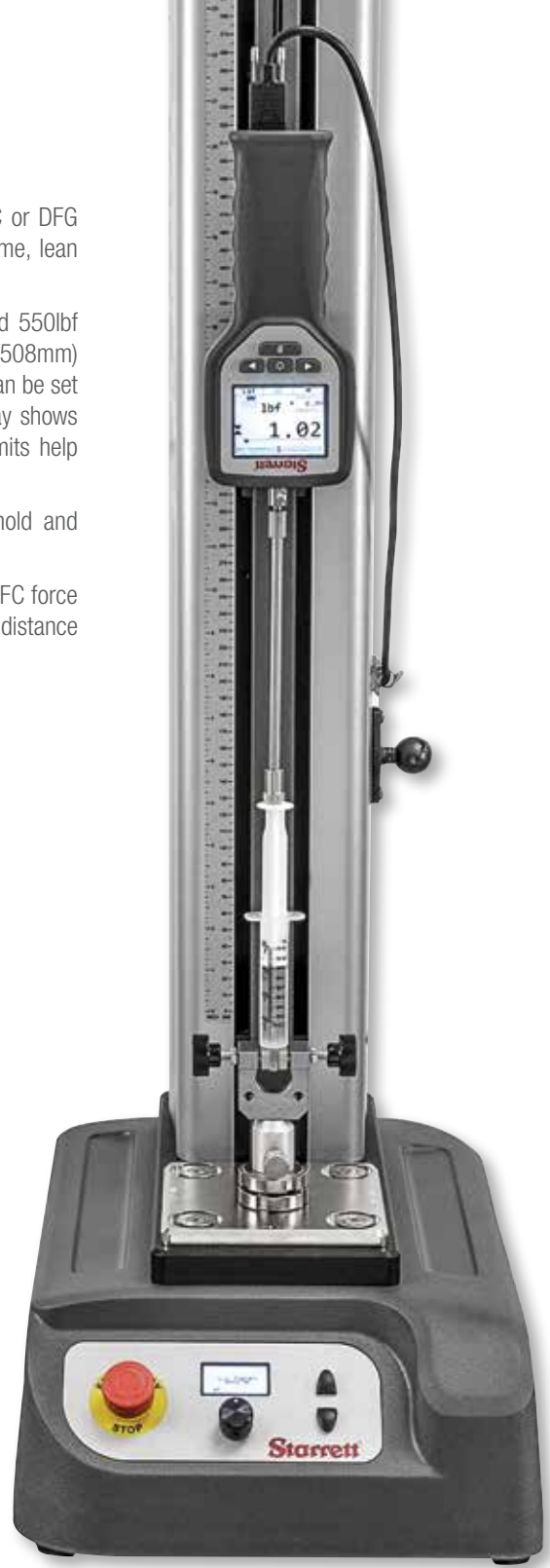

NEW!

MATERIAL TESTING / FORCE MEASUREMENT



NEW!

MATERIAL TESTING / FORCE MEASUREMENT

DIGITAL FORCE TESTERS



FEATURES

- Crosshead position accuracy is better than 20 μ m (0.0008 in)
- Two column heights and travels:
 - Standard Travel 20" (508mm)
 - Extended Travel 30" (762mm)
- Three force capacities:
 - 110 lbf (500N)
 - 330 lbf (1500N)
 - 550 lbf (2500N)
- Reference distance travel ruler
- Cycle for 99,999 counts or seconds (72 hours)
- Hold at load or duration for up to seconds (72 hours)
- Compact design is ideal for small work space and for lean manufacturing environments
- Adjustable base adapter ensure correct sample alignment
- Standard metric base with M4, M6, M10 and M12 threads
- Optional imperial base with #10-32, 5/16-18, 1/4-28 and 1/2-20 threads
- USB 2.0 and RS-232 Communications
- Configurable crosshead speeds from:
 - 0.002 to 40 in/min
 - 0.05 to 1000 mm/min
- Crosshead speed accuracy is better than 0.1% at full speed, full load
- Adjustable, magnetic travel limits
- Quiet operating even at full speed, full load
- Easily upgrade from force gage control to computer-based operation using L1 software and 2-in-1 tablet PC
- Two mounting blocks for:
 - Force gage mounting
 - BLC load cell mounting
- Four configurable 0-24Vdc digital I/O channels for switch testing or use with annunciators and status lamps
- Base clevis adapter kit supplied standard
- Cast-aluminum base with bench clips to secure to work space if needed
- Easy-to-use jog keys with excellent tactile feedback
- Speed selection dial with high resolution display



DIGITAL FORCE TESTERS

FOR USE WITH L1 SOFTWARE AND DIGITAL FORCE GAGES

SPECIFICATIONS

| FMM - Digital Force Testers | | Standard Travel | | | Extended Travel | | |
|-------------------------------------|----------|--|---------------|---------------|-----------------|---------------|---------------|
| Models | | FMM-110 | FMM-330 | FMM-550 | FMM-110X | FMM-330X | FMM-550X |
| Load Capacity, Full Scale | Lbf | 110 | 330 | 550 | 110 | 330 | 550 |
| | N | 500 | 1500 | 2500 | 500 | 1500 | 2500 |
| | Kgf | 50 | 150 | 250 | 50 | 150 | 250 |
| Crosshead Speed, Minimum | inch/min | 0.002 | | | | | |
| | mm/min | 0.05 | | | | | |
| Crosshead Speed, Maximum | inch/min | 40 | | | | | |
| | mm/min | 1000 | | | | | |
| Maximum Speed, Full Load | inch/min | 40 | | | | | |
| | mm/min | 1000 | | | | | |
| Accuracy- Speed | | Better than 0.1% of test speed | | | | | |
| Accuracy- Crosshead Position | inch | Better than 0.0008 | | | | | |
| | mm | Better than 0.02mm | | | | | |
| Travel Resolution | inch | 0.001 | | | | | |
| | mm | 0.025 | | | | | |
| Axial Frame Stiffness | lbf/in | 13,750 | 17,368 | 17,742 | 12,222 | 13,750 | 14,865 |
| | kN/mm | 2.5 | 3.1 | 3.1 | 2.2 | 2.5 | 2.5 |
| Cycling, Maximum | Counts | 99,999 | | | | | |
| | Duration | 27 hours | | | | | |
| Constant Hold, Maximum | Duration | 27 hours | | | | | |
| Vertical Test Space ¹ | inch | 22 | | | 32 | | |
| | mm | 559 | | | 813 | | |
| Crosshead Travel | inch | 20 | | | 30 | | |
| | mm | 508 | | | 762 | | |
| Communication | | USB 2.0, RS-232, | | | | | |
| Input/Output Channels | | 0 - 24Vdc (independent, configurable) | | | | | |
| Power | | Single Phase Voltage (Vac) +10% 110, 120, 220, 230, 240 50/60 Hz | | | | | |
| Using 117V Mains at Full Scale Load | | 0.09A Holding | 0.11A Holding | 0.18A Holding | 0.09A Holding | 0.11A Holding | 0.18A Holding |
| | | 10.5 Watts | 12.9 Watts | 21.1 Watts | 10.5 Watts | 12.9 Watts | 21.1 Watts |
| Operating Temperature | °F | +40 to +110 | | | | | |
| | °C | +5 to +43 | | | | | |
| Humidity | | 10 to 90%, non-condensing | | | | | |
| Throat | inch | 3.9 | | | | | |
| | mm | 100 | | | | | |
| Height | inch | 37 | | | 47 | | |
| | mm | 940 | | | 1194 | | |
| Width | inch | 11.5 | | | | | |
| | mm | 292 | | | | | |
| Depth | inch | 16.5 | | | | | |
| | mm | 419 | | | | | |
| Base Plate Threads | inch | #10-32, 5/16-18, 1/4-28, 1/2-20 (optional) | | | | | |
| | mm | M4, M6, M10, M12 (standard) | | | | | |
| Weight (approx.) | lbs | 80 | | | 95 | | |
| | kgs | 36.3 | | | 43 | | |
| CE Compliance | | Meets all relevant CE standards for safety, immunity, noise | | | | | |

NOTES

¹Total vertical space is the distance from the top surface of the base plate to the bottom surface of the crosshead.



The standard base plate features four hole patterns for mounting fixtures; M4, M6, M10 and M12. An optional imperial base plate features #10-32, 5/16-18, 1/4-28, and 1/2-20. The base plate can be easily positioned to ensure correct sample alignment.

Two mounting blocks are available for attaching a Starrett force gage or the BLC Series load cell. The blocks attach easily and securely to the crosshead and ensure correct center line alignment.

A stainless steel clevis set is included with the FMM test frame base. The clevis will accept 15.9mm diameter test fixtures. The clevis set includes the clevis, locking rings, grip pin and a spanner wrench.

NEW!

MATERIAL TESTING / FORCE MEASUREMENT



MATERIAL TEST FRAMES

FOR USE WITH L3 SOFTWARE

SPECIFICATIONS

| MMx Material Testing Frames | | | | | | | | | |
|--|--------|--|----------|----------|----------|--|---------|---------|--|
| Model No. | | MMS-500 | MMS-1000 | MMS-2500 | MMS-5000 | MMD-10K | MMD-30K | MMD-50K | |
| Load Capacity | N | 500 | 1000 | 2500 | 5000 | 10,000 | 30,000 | 50,000 | |
| | kgf | 50 | 100 | 250 | 500 | 1000 | 3000 | 5000 | |
| | lbf | 112 | 225 | 562 | 1124 | 2250 | 6750 | 11,250 | |
| Minimum Speed | mm/min | 0.001 | 0.001 | 0.001 | 0.001 | 0.001 | 0.001 | 0.001 | |
| | in/min | 0.00004 | 0.00004 | 0.00004 | 0.00004 | 0.00004 | 0.00004 | 0.00004 | |
| Maximum Speed | mm/min | 1525 | 1525 | 1525 | 1525 | 1525 | 1525 | 752 | |
| | in/min | 60 | 60 | 60 | 60 | 60 | 60 | 30 | |
| Position Control Resolution | µm | 0.0625 | 0.0625 | 0.0625 | 0.0625 | 0.05 | 0.025 | 0.025 | |
| | µin | 2.4 | 2.4 | 2.4 | 2.4 | 1.9 | 0.9 | 0.9 | |
| Vertical Test Space ¹ | mm | 559 | 953 | 1257 | 1257 | 1270 | 1245 | 1220 | |
| | in | 22 | 37.5 | 49.5 | 49.5 | 50 | 49 | 48 | |
| Total Crosshead Travel | mm | 381 | 762 | 1016 | 1016 | 1162 | 1137 | 1111 | |
| | in | 15 | 30 | 40 | 40 | 45.75 | 44.75 | 43.75 | |
| Throat | mm | 100 | 100 | 100 | 100 | 424 | 424 | 424 | |
| | in | 4 | 4 | 4 | 4 | 16.7 | 16.7 | 16.7 | |
| Accuracy Load Measurement | | Load Cell Sensor Dependent | | | | Load Cell Sensor Dependent | | | |
| Accuracy Position Measurement ² | | ±0.0002 inch (±5 µm) | | | | ±0.0002 inch (±5 µm) | | | |
| Accuracy Strain Measurement | | ±0.5% of reading down to 1/50 of full scale with ASTM E83 class B or ISO 9513 class 0.5 extensometer | | | | ±0.5% of reading down to 1/50 of full scale with ASTM E83 class B or ISO 9513 class 0.5 extensometer | | | |
| Accuracy Crosshead Speed | | ±0.1% of set speed | | | | ±0.1% of set speed | | | |
| Data Sampling | Hz | 1 to 2000 | | | | 1 to 2000 | | | |
| Digital I/O | | 8 channels @ 1-5V | | | | 8 channels @ 1-5V | | | |
| Extensometer Connections | | 2 channels for 0-10V extensometers | | | | 2 channels for 0-10V extensometers | | | |
| Analog Inputs | | 1 channel @ ±10V | | | | 1 channel @ ±10V | | | |
| Analog Outputs | | 2 channels @ 0-10V | | | | 2 channels @ 0-10V | | | |
| Electrical Phase | | 1 | | | | 1 | | | |
| Power Requirements | | 100, 120, 220, 230, 240VAC 10%; 47-63Hz Self-identifying | | | | 100, 120, 220, 230, Single Phase Voltage 240Vac 10% (Vac) ±10% 220-240V (Vac) ±10% 220-240V | | | |
| Operating Temperature | °C | +5° to +40°C | | | | +5° to +40°C | | | |
| | °F | +41° to 104°F | | | | +41° to 104°F | | | |
| Storage Temperature | °C | -40° to +66°C | | | | -40° to +66°C | | | |
| | °F | -40° to 150°F | | | | -40° to 150°F | | | |
| Humidity | | +10% to +90%, non-condensing | | | | +10% to +90%, non-condensing | | | |
| Total Height | mm | 805 | 1218 | 1573 | 1573 | 1685 | 1711 | 1711 | |
| | in | 31.7 | 47.9 | 61.9 | 61.9 | 66.4 | 67.4 | 67.4 | |
| Total Width | mm | 381 | 381 | 381 | 381 | 787 | 787 | 787 | |
| | in | 15 | 15 | 15 | 15 | 31 | 31 | 31 | |
| Total Depth | mm | 514 | 514 | 514 | 514 | 724 | 724 | 724 | |
| | in | 20.3 | 20.3 | 20.3 | 20.3 | 28.5 | 28.5 | 28.5 | |
| Weight | kg | 61 | 77 | 88 | 88 | 136 | 192 | 225 | |
| | lb | 135 | 170 | 195 | 195 | 300 | 425 | 500 | |

Notes

Total vertical space is the distance from the top surface of the base plate to the bottom surface of the crosshead, excluding load cell sensor, test fixtures, and clevis adapter. Assumes Linear Error Correction and Deflection Compensation has been performed on test frame.

MMS and MMD test frames may be used with extensometers from Reliant Technologies and Epsilon Technology Corporation. Extensometers can be "plug and play" when specified for Starrett equipment.

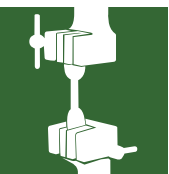

FORCE MEASUREMENT TEST FRAMES

FOR USE WITH L3, L2 PLUS, L2 AND S2 SOFTWARE

SPECIFICATIONS

| FMx Force Measurement Frames | | | | | | | | |
|--|--------|--|----------|----------|----------|--------------------------------|--|--|
| Model No. | | FMS-500 | FMS-1000 | FMS-2500 | FMS-5000 | FMD-10K | FMD-30K | FMD-50K |
| Load Capacity | N | 500 | 1000 | 2500 | 5000 | 10,000 | 30,000 | 50,000 |
| | kgf | 50 | 100 | 250 | 500 | 1000 | 3000 | 5000 |
| | lbf | 112 | 225 | 562 | 1124 | 2250 | 6750 | 11,250 |
| Minimum Speed | mm/min | 0.05 | 0.05 | 0.05 | 0.05 | 0.001 | 0.001 | 0.001 |
| | in/min | 0.002 | 0.002 | 0.002 | 0.002 | 0.00004 | 0.00004 | 0.00004 |
| Maximum Speed | mm/min | 1525 | 1525 | 1525 | 1525 | 1525 | 1525 | 752 |
| | in/min | 60 | 60 | 60 | 60 | 60 | 60 | 30 |
| Position Control Resolution | µm | 0.250 | 0.250 | 0.250 | 0.250 | 0.05 | 0.025 | 0.025 |
| | µin | 9.8 | 9.8 | 9.8 | 9.8 | 1.9 | 0.9 | 0.9 |
| Vertical Test Space ¹ | mm | 559 | 953 | 1257 | 1257 | 1270 | 1245 | 1220 |
| | in | 22 | 37.5 | 49.5 | 49.5 | 50 | 49 | 48 |
| Total Crosshead Travel | mm | 381 | 762 | 1016 | 1016 | 1162 | 1137 | 1111 |
| | in | 15 | 30 | 40 | 40 | 45.75 | 44.75 | 43.75 |
| Throat | mm | 100 | 100 | 100 | 100 | 424 | 424 | 424 |
| | in | 4 | 4 | 4 | 4 | 16.7 | 16.7 | 16.7 |
| Accuracy Load Measurement | | Load Cell Sensor Dependent | | | | Load Cell Sensor Dependent | | |
| Accuracy Position Measurement ² | | ±0.001inch (±20µm) | | | | ±0.0002inch (±5µm) | | |
| Accuracy Crosshead Speed | | ±0.1% of set speed | | | | ±0.1% of set speed | | |
| Data Sampling | Hz | 5 to 1000 | | | | 5 to 1000 | | |
| Digital I/O | | 8 channels @ 1-5V | | | | 8 channels @ 1-5V | | |
| Electrical Phase | | 1 | | | | 1 | | |
| Power Requirements | | 100, 120, 220, 230, 240VAC 10%; 47-63Hz Self-identifying | | | | 100, 120, 220, 230, 240Vac 10% | Single Phase Voltage (Vac) ±10% 220-240V | Single Phase Voltage (Vac) ±10% 220-240V |
| Operating Temperature | °C | +10° to +38°C | | | | +10° to +38°C | | |
| | °F | +50° to 100°F | | | | +50° to 100°F | | |
| Storage Temperature | °C | -40° to +66°C | | | | -40° to +66°C | | |
| | °F | -40° to 150°F | | | | -40° to 150°F | | |
| Humidity | | +10% to +90%, non-condensing | | | | +10% to +90%, non-condensing | | |
| Total Height | mm | 805 | 1218 | 1573 | 1573 | 1685 | 1711 | 1711 |
| | in | 31.7 | 47.9 | 61.9 | 61.9 | 66.4 | 67.4 | 67.4 |
| Total Width | mm | 381 | 381 | 381 | 381 | 787 | 787 | 787 |
| | in | 15 | 15 | 15 | 15 | 31 | 31 | 31 |
| Total Depth | mm | 514 | 514 | 514 | 514 | 724 | 724 | 724 |
| | in | 20.3 | 20.3 | 20.3 | 20.3 | 28.5 | 28.5 | 28.5 |
| Weight | kg | 61 | 77 | 88 | 88 | 136 | 192 | 225 |
| | lb | 135 | 170 | 195 | 195 | 300 | 425 | 500 |

Notes

Total vertical space is the distance from the top surface of the base plate to the bottom surface of the crosshead, excluding load cell sensor, test fixtures, and clevis adapter. Assumes Linear Error Correction and Deflection Compensation has been performed on test frame.

Shown: L2 system with FMS500 test frame with tablet.



TEST FRAME DIMENSIONS

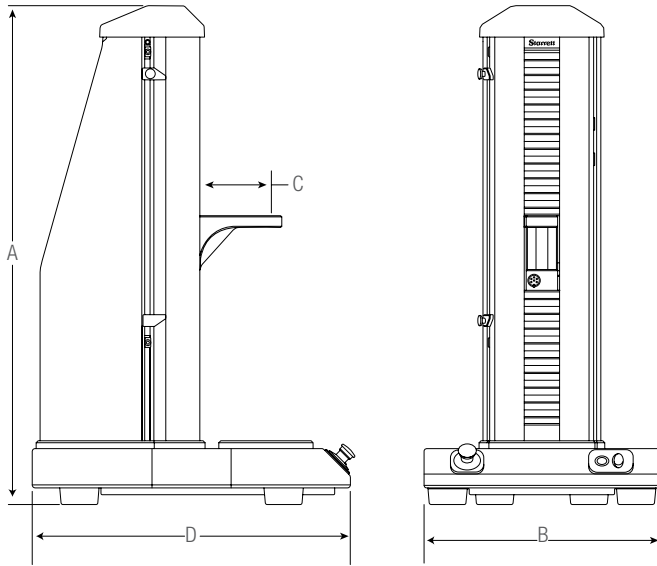

Single Column Test Frames

| Model | A | | B | | C | | D | |
|------------------------|------|-----|------|-----|-----|-----|------|-----|
| | in | mm | in | mm | in | mm | in | mm |
| MMS/FMS-500 Test Frame | 31.7 | 805 | 15.0 | 381 | 4.2 | 107 | 20.3 | 514 |

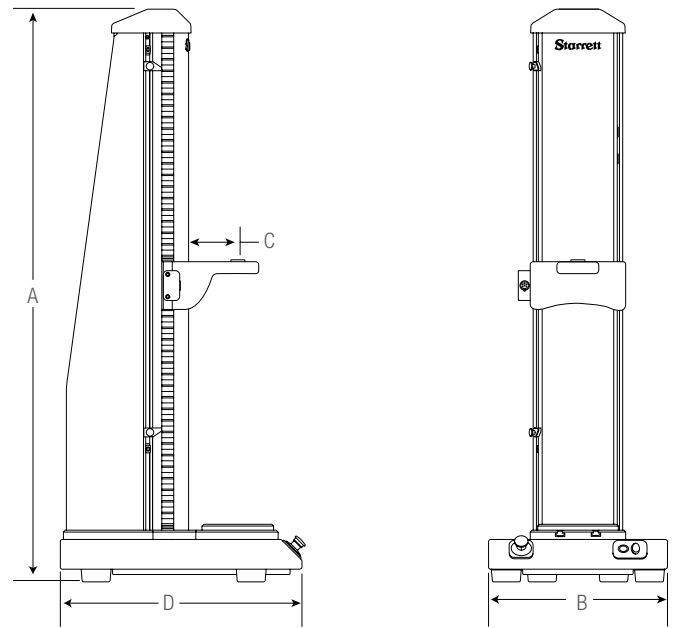

Single Column Test Frames

| Model | A | | B | | C | | D | |
|-------------------------|------|------|----|-----|-----|-----|------|-----|
| | in | mm | in | mm | in | mm | in | mm |
| MMS/FMS-1000 Test Frame | 47.9 | 1218 | 15 | 381 | 4.1 | 105 | 20.3 | 514 |
| MMS/FMS-2500 Test Frame | 61.9 | 1573 | 15 | 381 | 4.1 | 105 | 20.3 | 514 |
| MMS/FMS-5000 Test Frame | 61.9 | 1573 | 15 | 381 | 4.1 | 105 | 20.3 | 514 |

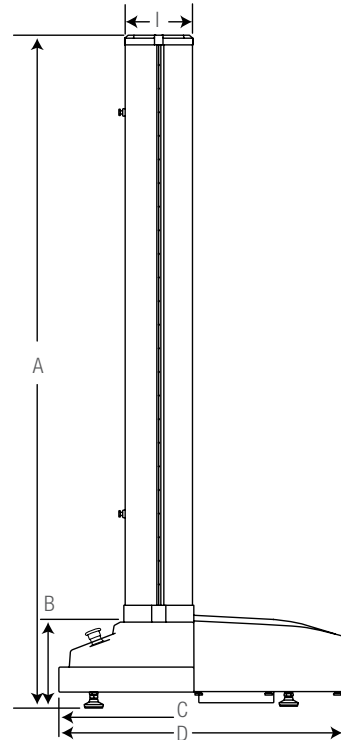
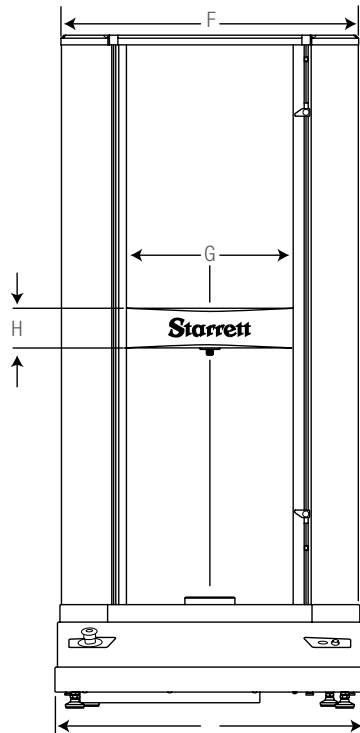

Dual Column Test Frames

| Model | A | | B | | C | | D | | E | F | | G | | H | I | | | |
|------------------------|------|------|------|-----|----|-----|------|-----|----|-----|------|-----|------|-----|----|-----|-----|-----|
| | in | mm | in | mm | in | mm | in | mm | | in | mm | in | mm | | in | mm | | |
| MMD/FMD-10K Test Frame | 66.4 | 1685 | 9.4 | 238 | 10 | 254 | 28.5 | 724 | 31 | 787 | 29.7 | 754 | 16.7 | 424 | 3 | 76 | 6.7 | 170 |
| MMD/FMD-30K Test Frame | 67.4 | 1711 | 10.4 | 263 | 10 | 254 | 28.5 | 724 | 31 | 787 | 29.7 | 754 | 16.7 | 424 | 4 | 102 | 6.7 | 170 |
| MMD/FMD-50K Test Frame | 67.4 | 1711 | 10.4 | 263 | 10 | 254 | 28.5 | 724 | 31 | 787 | 29.7 | 754 | 16.7 | 424 | 5 | 127 | 6.7 | 170 |



TEST FRAME DIMENSIONS

FMM STANDARD TRAVEL

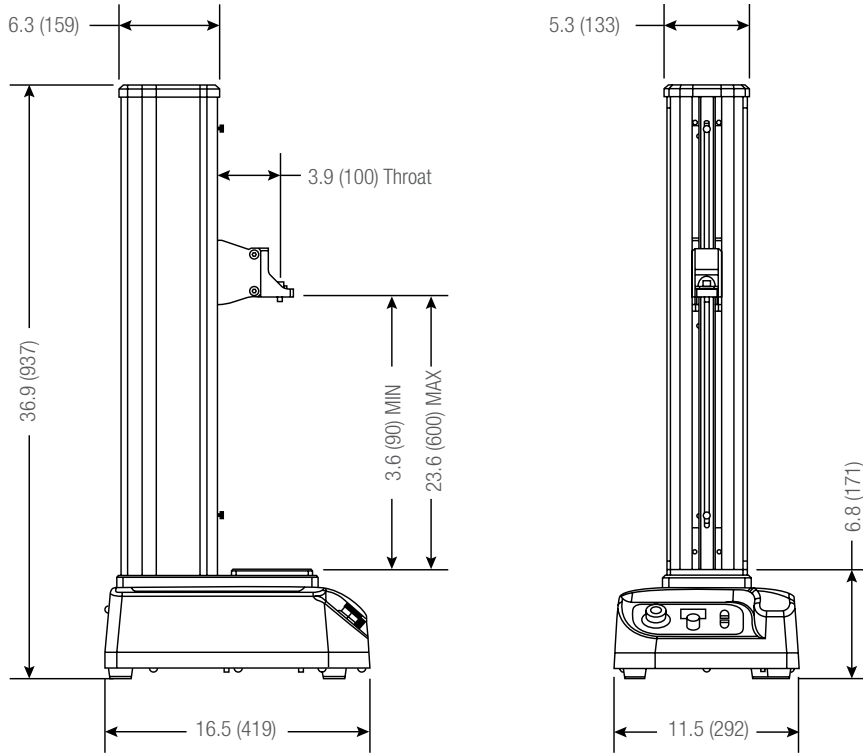

FMM EXTENDED TRAVEL

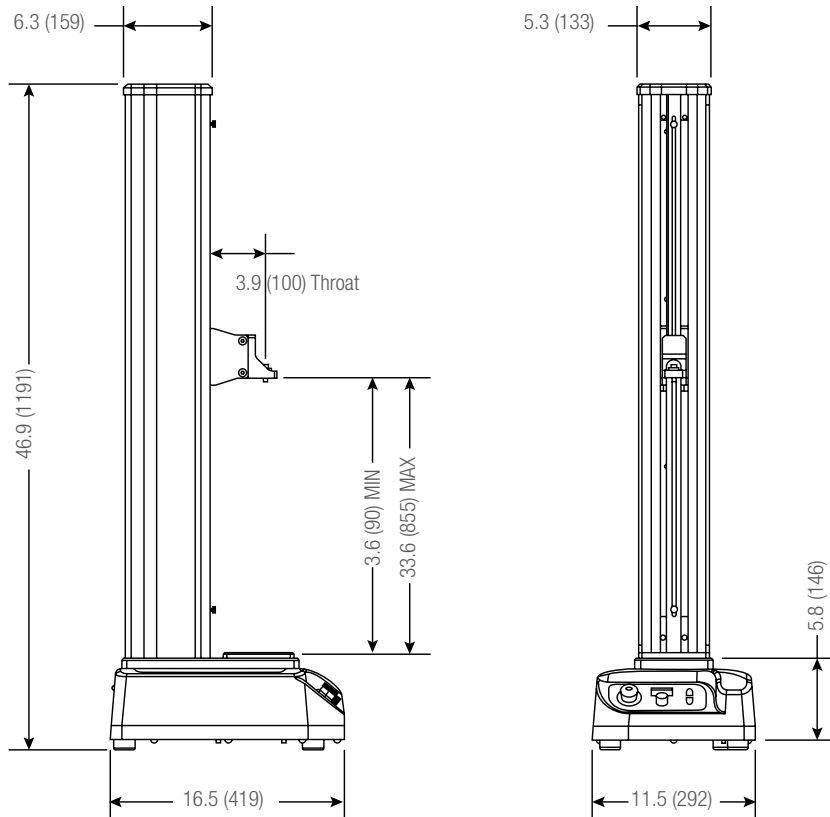

LOAD CELL SENSORS

Offering a full range of precision load cell sensors for material testing, force analysis and force measurement applications. Starrett load cells are compliant with IEEE 1451.4 and meet or exceed ASTM E4, BS 1610, ISO 7500-1 and EN 10002-2.

Measurement accuracies of $\pm 0.05\%$ of reading down to 1/100 of sensor capacity may be achieved. Sensors are supplied with a NIST-traceable Certificate of Calibration. Starrett recommends on-site verification of accuracy during installation. Sensor calibration should be performed at least annually.

MLC LOAD CELL SENSORS

The MLC Load Cell Sensor is a full-bridge, temperature compensated, strain gage instruments designed and optimized for material testing applications. These low profile sensors feature high axial stiffness and minimal deflection at full capacity which leads to improved measurement accuracy.

The MLC Sensors are general purpose sensors available in capacities from 125N to 50kN.



| MLC Low Profile Sensors | | | | | | | | | | | |
|-------------------------|---------------|-------|--------|-------------------------------|-----------------------|------|---------------------|-------|-------|-------|--------------|
| Model No. | Load Capacity | | | Safe Overload % Full Scale | Full Scale Deflection | | Height ¹ | | Width | | Thread mm |
| | N | KGF | LBF | | in | mm | in | mm | in | mm | |
| MLC-125 | 125 | 13 | 28 | 150 | 0.003 | 0.08 | 1.5 | 38.1 | 2.75 | 69.8 | M6 x 1-6H |
| MLC-250 | 250 | 25 | 56 | 150 | 0.003 | 0.08 | 1.5 | 38.1 | 2.75 | 69.8 | M6 x 1-6H |
| MLC-500 | 500 | 50 | 112 | 150 | 0.003 | 0.08 | 1.5 | 38.1 | 2.75 | 69.8 | M6 x 1-6H |
| MLC-1000 | 1,000 | 100 | 225 | 150 | 0.003 | 0.08 | 1.5 | 38.1 | 2.75 | 69.8 | M6 x 1-6H |
| MLC-1500 | 1,500 | 150 | 337 | 150 | 0.001 | 0.03 | 2.51 | 63.51 | 4.13 | 104.8 | M16 x 2-4H |
| MLC-2500 | 2,500 | 250 | 562 | 150 | 0.001 | 0.03 | 2.51 | 63.51 | 4.13 | 104.8 | M16 x 2-4H |
| MLC-5K | 5,000 | 500 | 1,124 | 150 | 0.001 | 0.03 | 2.51 | 63.51 | 4.13 | 104.8 | M16 x 2-4H |
| MLC-10K | 10,000 | 1,000 | 2,248 | 150 | 0.001 | 0.03 | 2.51 | 63.51 | 4.13 | 104.8 | M16 x 2-4H |
| MLC-25K | 25,000 | 2,500 | 5,620 | 150 | 0.002 | 0.05 | 2.51 | 63.51 | 4.13 | 104.8 | M16 x 2-4H |
| MLC-50K | 50,000 | 5,000 | 11,250 | 150 | 0.002 | 0.05 | 2.51 | 63.51 | 4.13 | 104.8 | M16 x 2-4H |

NOTES

- Dimension includes the base adapter. These MLC sensors are supplied with the base adapter standard. Base adapters are recommended for any MLC sensor. Load measurement accuracy is $\pm 0.05\%$ of reading down to 1/100 of load cell capacity. Display resolution is 10,000:1.
- For FMS, MMS, FMD or MMD frames.

BLC LOAD CELL SENSORS

BLC load cell sensors are full-bridge, temperature compensated, strain gage instruments designed and optimized for basic force testing applications. These S-beam sensors feature high axial stiffness and minimal deflection at full capacity which leads to improved measurement accuracy.

The BLC sensors are general purpose sensors available in capacities from 2lbf to 500lbf (10 to 2500N). These sensors are used exclusively with L1 Systems.

| BLC - Basic Force Measurement S-beam Sensors | | | | | | | | | | | |
|--|---------------|-----|-----|-------------------------------|-----------------------|------|--------|------|-------|------|---------------|
| Model Number | Load Capacity | | | Safe Overload % Full Scale | Full Scale Deflection | | Height | | Width | | Thread mm |
| | N | KGF | LBF | | in | mm | in | mm | in | mm | |
| BLC-2 | 10 | 1 | 2 | 150 | 0.009 | 0.22 | 3.0 | 76.2 | 3.0 | 76.2 | M6 x 1-6H |
| BLC-5 | 20 | 2 | 5 | 150 | 0.008 | 0.21 | 3.0 | 76.2 | 3.0 | 76.2 | M6 x 1-6H |
| BLC-10 | 50 | 5 | 10 | 150 | 0.007 | 0.18 | 3.0 | 76.2 | 3.0 | 76.2 | M6 x 1-6H |
| BLC-20 | 100 | 10 | 20 | 150 | 0.007 | 0.18 | 2.0 | 50.8 | 2.0 | 50.8 | M6 x 1-6H |
| BLC-50 | 250 | 25 | 50 | 150 | 0.006 | 0.15 | 2.0 | 50.8 | 2.0 | 50.8 | M6 x 1-6H |
| BLC-100 | 500 | 50 | 110 | 150 | 0.003 | 0.08 | 2.0 | 50.8 | 2.0 | 50.8 | M6 x 1-6H |
| BLC-200 | 1000 | 100 | 225 | 150 | 0.003 | 0.08 | 2.0 | 50.8 | 2.0 | 50.8 | M6 x 1-6H |
| BLC-500 | 2500 | 250 | 550 | 150 | 0.005 | 0.13 | 2.0 | 50.8 | 2.0 | 50.8 | M12 x 1.75-5H |

NOTES

- Load measurement accuracy is $\pm 0.1\%$ of load cell capacity. Display resolution is 10,000:1.
- For FMM frames.

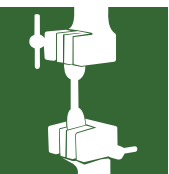

LOAD CELL SENSORS

FLC LOAD CELL SENSORS

Three models of s-beam load cell sensors are also available. These are all full bridge, temperature compensated strain gage instruments, designed for force measurement applications, but suitable for some material testing applications.



PREMIUM MODELS

Ideal for low load applications, these sensors have a safe overload rating of 1000% of the sensor's load capacity.

| FLC-P "Premium" S-beam Sensors | | | | | | | | | | | | |
|--------------------------------|---------------|-----|-----|-------------------------------|-----------------------|-----|--------|------|-------|------|--------------|--|
| Model No. | Load Capacity | | | Safe Overload % Full Scale | Full Scale Deflection | | Height | | Width | | Thread mm | |
| | N | KGf | LBF | | in | mm | in | mm | in | mm | | |
| FLC-5P | 5 | 0.5 | 1 | 1000 | 0.014 | 0.4 | 2.48 | 63.0 | 2.33 | 59.2 | M6 x 1-6H | |
| FLC-10P | 10 | 1 | 2 | 1000 | 0.012 | 0.3 | 2.48 | 63.0 | 2.33 | 59.2 | M6 x 1-6H | |
| FLC-25P | 25 | 2.5 | 5 | 1000 | 0.012 | 0.3 | 2.48 | 63.0 | 2.33 | 59.2 | M6 x 1-6H | |
| FLC-50P | 50 | 5 | 11 | 1000 | 0.009 | 0.2 | 2.48 | 63.0 | 2.33 | 59.2 | M6 x 1-6H | |
| FLC-100P | 100 | 10 | 22 | 1000 | 0.009 | 0.2 | 2.48 | 63.0 | 2.33 | 59.2 | M6 x 1-6H | |
| FLC-250P | 250 | 25 | 56 | 1000 | 0.009 | 0.2 | 2.48 | 63.0 | 2.33 | 59.2 | M6 x 1-6H | |

- NOTES**
1. Load measurement accuracy is $\pm 0.1\%$ of load cell capacity. Display resolution is 10,000:1.
 2. For FMS, MMS, FMD or MMD frames.

SEALED MODELS

These models are suitable for applications in non-laboratory environments where dirt, oil, dust and debris may be present.

| FLC "Sealed" S-beam Sensors | | | | | | | | | | | | |
|-----------------------------|---------------|-----|-------|-------------------------------|-----------------------|------|--------|------|-------|------|---------------|--|
| Model No. | Load Capacity | | | Safe Overload % Full Scale | Full Scale Deflection | | Height | | Width | | Thread mm | |
| | N | KGf | LBF | | in | mm | in | mm | in | mm | | |
| FLC-500 | 500 | 50 | 112 | 150 | 0.004 | 0.10 | 2.5 | 63.0 | 2.0 | 50.8 | M6 x 1-6H | |
| FLC-1000 | 1,000 | 100 | 225 | 150 | 0.006 | 0.15 | 2.5 | 63.0 | 2.0 | 50.8 | M6 x 1-6H | |
| FLC-2000 | 2,000 | 200 | 450 | 150 | 0.005 | 0.13 | 3.0 | 76.2 | 2.0 | 50.8 | M12 x 1.75-5H | |
| FLC-2500 | 2,500 | 250 | 562 | 150 | 0.005 | 0.13 | 3.0 | 76.2 | 2.0 | 50.8 | M12 x 1.75-5H | |
| FLC-5KN | 5,000 | 500 | 1,124 | 150 | 0.005 | 0.13 | 3.0 | 76.2 | 2.0 | 50.8 | M12 x 1.75-5H | |

- NOTES**
1. Load measurement accuracy is $\pm 0.1\%$ of load cell capacity. Display resolution is 10,000:1.
 2. For FMS, MMS, FMD or MMD frames.

ECONOMY MODELS

When price is an issue, these general purpose load cell sensors are economical and suitable for most general purpose force measurement applications.

| FLC-E "Economy" S-beam Sensors | | | | | | | | | | | | |
|--------------------------------|---------------|-----|-------|-------------------------------|-----------------------|------|--------|------|-------|------|---------------|--|
| Model No. | Load Capacity | | | Safe Overload % Full Scale | Full Scale Deflection | | Height | | Width | | Thread mm | |
| | N | KGf | LBF | | in | mm | in | mm | in | mm | | |
| FLC-50E | 50 | 5 | 11 | 150 | 0.003 | 0.08 | 2.5 | 63.5 | 2.0 | 50.8 | M6 x 1-6H | |
| FLC-100E | 100 | 10 | 22 | 150 | 0.003 | 0.08 | 2.5 | 63.5 | 2.0 | 50.8 | M6 x 1-6H | |
| FLC-200E | 200 | 20 | 45 | 150 | 0.003 | 0.08 | 2.5 | 63.5 | 2.0 | 50.8 | M6 x 1-6H | |
| FLC-500E | 500 | 50 | 112 | 150 | 0.004 | 0.10 | 2.5 | 63.5 | 2.0 | 50.8 | M6 x 1-6H | |
| FLC-1000E | 1,000 | 100 | 225 | 150 | 0.006 | 0.15 | 2.5 | 63.5 | 2.0 | 50.8 | M6 x 1-6H | |
| FLC-2000E | 2,000 | 200 | 450 | 150 | 0.006 | 0.15 | 3.0 | 76.2 | 2.0 | 50.8 | M12 x 1.75-5H | |
| FLC-2500E | 2,500 | 250 | 562 | 150 | 0.005 | 0.13 | 3.0 | 76.2 | 2.0 | 50.8 | M12 x 1.75-5H | |
| FLC-5000E | 5,000 | 500 | 1,124 | 150 | 0.005 | 0.13 | 3.0 | 76.2 | 2.0 | 50.8 | M12 x 1.75-5H | |

- NOTES**
1. Load measurement accuracy is $\pm 0.1\%$ of load cell capacity. Display resolution is 10,000:1.
 2. For FMS, MMS, FMD or MMD frames.



ACCESSORIES

TEST FIXTURES, EXTENSOMETERS, SHIELDS

TEST FIXTURES

We offer a full range of test fixtures, grips and accessories. Test fixtures are compatible with all Starrett systems and test frames. We can also engineer and supply custom test fixtures to your exact requirements.

TYPES

- Button Head
- Compression Cages
- Flexural
- Hydraulic
- Peel
- Platens
- Pneumatic
- Ribbon
- Roller
- Scissor
- Shear
- Vice-action
- Wedge-action

SPECIMEN DIES

Dies are available for testing a variety of materials including rubber, plastic, elastomer, fabric, paper, films and more. Dies are engineered to comply with common testing standards including:

- ASTM D-412 (A,B,C,D,F)
- ASTM D-638 (I, II, III, IV, V)
- ISO 34 (A,B)
- BS 6746
- IEC 540



Starrett specimen dies help ensure accurate dimensions for your sample preparations.



Starrett can supply a wide assortment of testing fixtures that comply with international testing standards from ASTM, ISO, DIN, TAPPI and more. We can also supply custom test fixtures for difficult sample shapes.



EXTENSOMETRY

Starrett is compatible with a full range of contact-type extensometers. Our systems are compatible with Reliant Technologies® and Epsilon® extensometers and feature automatic identification of model and measuring range.

- Types
- Axial
- Traverse
- Bi-axial
- Averaging
- Miniature
- Long Gage Length, Small Range
- Long Gage Length
- High Elongation



SPLINTER SHIELDS

Optional splinter shields are available for both single- and dual column testers. Shields feature electronic interlocks and are constructed of shatter-resistant aerospace acrylic.



Our MMS and MMD material test frames may be used with extensometers. These L3 Systems may use extensometers from Reliant Technologies and Epsilon Technology Corporation.

Extensometers are customized so that they are automatically recognized by the L3 system. Selecting the Extensometer symbol will display key characteristics of the instrument including measuring range.

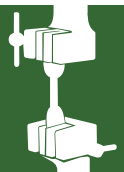

DIGITAL FORCE GAGES

FOR ADVANCED AND BASIC TESTING APPLICATIONS

Starrett digital force gages can be used as handheld force gages for basic applications or as a force sensor when used with a FMM Digital Force Tester, MTL and MTH Manual Tester. Listed are the various test methods that can be performed:

- **Limit Testing** - Use load, distance or a break condition and report results at the limit including maximum load and distance at maximum load.
- **Load Average Testing** - The load average test measures the load from the start and end of a test sequence.
- **Time Average Testing** - Set a time duration for a test. When load is measured at the start of the test, the test concludes at the end of the time duration. Average load is measured.
- **Cyclic Count Testing** - Define the number of cycles, up to 99,999 to be completed.
- **Cyclic Duration Testing** - Define the duration of cycles, up to 27 hours to be completed.
- **Constant Hold Testing** - Hold at a distance or load for creep and relaxation results. The maximum duration is 27 hours.
- **Contact Closure/Switch Testing** - Uses the DFC force gage to signal when an electronic switch is opened or closed as load is applied or removed.

| Tests | |
|-----------|---------|
| Test Mode | |
| Distance | |
| Type | Tension |
| Target | 50.00 |
| Speed | 25.00 |

Easy Test Setup

As a controller, the DFC can be used to measure load and control the FMM Test Frame. Create Load, Distance and Break Limit test methods in seconds.

| | | |
|---|---|----------|
| ▶ | ☰ | ▼ 3 |
| ▭ | ⊕ | 50.00mm |
| L | ↕ | 50.20 N |
| D | | 50.00 mm |
| | | |

Comprehensive Results

At the completion of your test, the DFC will display load and distance results. These can be saved to memory or exported for reporting.

DFC DIGITAL FORCE CONTROLLER

The DFC is a revolutionary concept for force measurement using a handheld force gage. The DFC may be used as a high-accuracy handheld force gage or as a digital controller for use with the FMM Digital Force Testers. The DFC can serve as a universal interface where you set up your tests and where you configure load limits, distance limits, break limits, crosshead travel direction, crosshead speed and more. The DFC features a measurement accuracy of 0.1% full scale with internal data sampling at 25kHz. Display resolution is 10,000:1. The DFC features Bluetooth®, USB and RS-232 communications plus digital I/O.



DFC mounted on FMM-550X Digital Force Tester

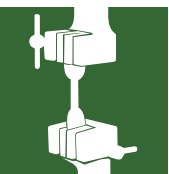

DFG DIGITAL FORCE CONTROLLER

The DFG is our basic force gage. The gage measures force at an accuracy of better than 0.2% full scale.

The DFG is ideal for basic tensile and compression testing. Test setup and operation is fast, efficient and easy for anyone. The DFG display shows the test direction and dynamic load during testing. Results are displayed at the completion of testing, including "Pass-Fail" when tolerance is applied. The gage will display statistics when results are saved to the gage's internal memory. Store up to 50 test results in local memory.

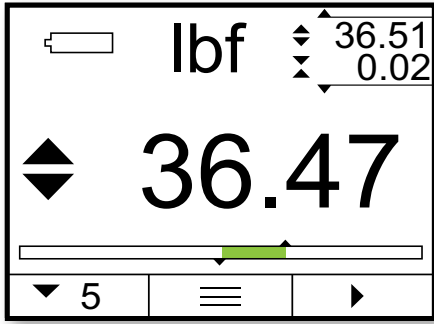

Real Time View

Primary window shows active load being applied to the load cell. The secondary windows shows the measured peak in tension made - 36.51lbf.

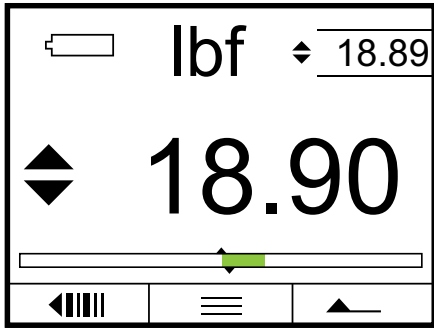

Tension Peak View

Shows maximum load measured in primary window. Secondary window shows real time load.

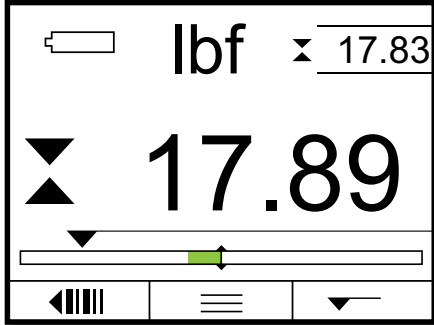

Compression Peak View

Shows maximum load measured in primary window. Secondary window shows real time load.

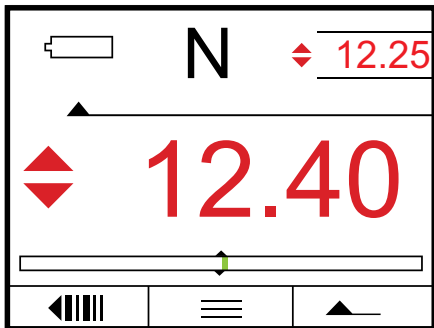

Tolerance View

When a tolerance is used, out-of-tolerance results display in red.

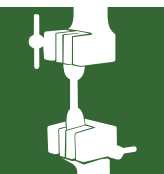

DIGITAL FORCE GAGES

FEATURES

- Use as handheld instrument or mount to Starrett test frames: FMM, MTL and MTH.
- Excellent display resolutions:
 - DFC 10,000:1
 - DFG 5,000:1
- Precise and accurate load measurements:
 - DFC 0.1% full scale
 - DFG 0.2% full scale
- Load sensors have safe overload rating of 200%
- High-resolution OLED color display with adjustable backlight and Auto Off feature
- Supplied with NIST-traceable Certificate of Calibration
- 3-year warranty
- Metric threads for screw-on attachments. Can be fitted with clevis adapters that fit hundreds of Starrett test fixtures.
- A primary and secondary display window shows your results. Out-of-tolerance results display in red.
- Adjustable sampling rates help you capture peak loads. Filters can be applied to peak and display values.
- Multiple display languages.
- Battery provides more than 30 hours of continuous operation. Charge battery using USB cable.
- Change display (Flip feature) orientation without having to expose electronics.
- Easy-to-use multi-function keypad. Softkeys are programmable to your most used functions.
- Programmable sounds for alarms, such as an out-of-tolerance result
- Cast-aluminum housing
- Comfort grip for handheld testing applications.



The USB connection is used for charging the battery or for transmitting data to a personal computer. The RS-232 cable is used for connection to the Starrett FMM Series digital tester. The DFC Series also has Bluetooth®.



DIGITAL FORCE GAGES

SPECIFICATIONS

| Digital Force Gages | | |
|--|-----------------------------|---------|
| Specification | DFC | DFG |
| Accuracy, Full Scale | 0.1% | 0.2% |
| Data Sampling (Hz) | 25,000 | 10,000 |
| Display Resolution | 10,000:1 | 5,000:1 |
| Safe Overload, Full Scale | 200% | 200% |
| Maximum Tare | 10% | 10% |
| Communications | | |
| Bluetooth® | Yes | No |
| USB 2.0 | Yes | Yes |
| RS-232 | Yes | Yes |
| Digital I/O | 2 channels | No |
| Memory, maximum results saved in gage | 99 | 50 |
| Operating Mode | | |
| Machine Control ¹ | Yes | No |
| Real Time | Yes | Yes |
| Peak Compression | Yes | Yes |
| Peak Tension | Yes | Yes |
| Load Limit | Yes | Yes |
| Break Limit | Yes | No |
| Load Average | Yes | No |
| Load-Time Average | Yes | No |
| Cyclic Count (99,999 maximum) | Yes | No |
| Cyclic Duration (27 hours) | Yes | No |
| Hold Duration (27 hours) | Yes | No |
| Contact Closure | Yes | No |
| Power, Environmental | | |
| Battery Type | Lithium Ion | |
| Battery Life, typical @ 20% brightness | >30 hours | |
| Charge Time, using 110/240V Mains | <3 hours | |
| Display | OLED High Resolution | |
| Operating Temperature | 40°F to 110°F (4°C to 43°C) | |
| Thread, for adapters | Metric M6, M10 | |
| Instrument Weight (approx.) | 3lbs (1.36kgs) | |

NOTES

- Machine control is exclusive to the DFC. When connected to the FMM Digital Force Tester, configuration of force gage and tester is performed through the gage.

ACCESSORY KITS

The DFC and DFG Force Gages are supplied with a complete accessory kit. The kit includes a hook, notch, chisel, flat, chisel and point adapter. A 6" extension rod is included. Adapter materials are stainless steel. Aluminum is used for 2lbf (10N) and 10lbf (50N) capacities.

Included with the force gage is a carrying case, USB cable, a set of testing accessories, a Quick Reference Guide and NIST-traceable Certificate of Calibration.



Force gage standard accessories

| DFC - Advanced Force Controller | | | | | | | | | | |
|---------------------------------|---------------|-----|-----|------|--------|----------------------------|-----------------------|------|--------------|---------------|
| Model Number | Load Capacity | | | | | Safe Overload % Full Scale | Full Scale Deflection | | Thread mm | Accessory Kit |
| | N | KGf | LBF | OZF | GF | | in | mm | | |
| DFC-2 | 10 | 1 | 2 | 32 | 900 | 200 | 0.013 | 0.33 | M6 x 1-6H | SPK-FG-A |
| DFC-5 | 20 | 2 | 5 | 80 | 2200 | 200 | 0.007 | 0.18 | M6 x 1-6H | SPK-FG-A |
| DFC-10 | 50 | 5 | 10 | 160 | 5000 | 200 | 0.006 | 0.15 | M6 x 1-6H | SPK-FG-S |
| DFC-20 | 100 | 10 | 20 | 320 | 10,000 | 200 | 0.008 | 0.20 | M6 x 1-6H | SPK-FG-S |
| DFC-50 | 250 | 25 | 50 | 800 | 25,000 | 200 | 0.015 | 0.39 | M6 x 1-6H | SPK-FG-S |
| DFC-100 | 500 | 50 | 110 | 1600 | 50,000 | 200 | 0.024 | 0.60 | M6 x 1-6H | SPK-FG-S |
| DFC-200 | 1000 | 100 | 225 | - | - | 200 | 0.021 | 0.54 | M6 x 1-6H | SPK-FG-M |
| DFC-500 | 2500 | 250 | 550 | - | - | 200 | 0.028 | 0.70 | M10 x 1.5-5H | SPK-FG-L |

NOTES

Load measurement accuracy is $\pm 0.1\%$ of load cell capacity. Display resolution is 10,000:1.

| DFG - Basic Force Controller | | | | | | | | | | |
|------------------------------|---------------|-----|-----|------|--------|----------------------------|-----------------------|------|--------------|---------------|
| Model Number | Load Capacity | | | | | Safe Overload % Full Scale | Full Scale Deflection | | Thread mm | Accessory Kit |
| | N | KGf | LBF | OZF | GF | | in | mm | | |
| DFG-10 | 50 | 5 | 10 | 160 | 5000 | 200 | 0.006 | 0.15 | M6 x 1-6H | SPK-FG-S |
| DFG-20 | 100 | 10 | 20 | 320 | 10,000 | 200 | 0.008 | 0.20 | M6 x 1-6H | SPK-FG-S |
| DFG-50 | 250 | 25 | 50 | 800 | 25,000 | 200 | 0.015 | 0.39 | M6 x 1-6H | SPK-FG-S |
| DFG-100 | 500 | 50 | 110 | 1600 | 50,000 | 200 | 0.024 | 0.60 | M6 x 1-6H | SPK-FG-S |
| DFG-200 | 1000 | 100 | 225 | - | - | 200 | 0.021 | 0.54 | M6 x 1-6H | SPK-FG-M |
| DFG-500 | 2500 | 250 | 550 | - | - | 200 | 0.028 | 0.70 | M10 x 1.5-5H | SPK-FG-L |

NOTES

Load measurement accuracy is $\pm 0.2\%$ of load cell capacity. Display resolution is 5,000:1.

NEW!

MATERIAL TESTING / FORCE MEASUREMENT



MANUAL FORCE TESTERS

MTL MANUAL TESTERS

The MTL Manual Testers are single column, manually-operated force testers. These testers operate with a quick-action lever in either tension or compression directions. Two models are available- the MTL-110 and MTL-330. Force measurement is performed using a Starrett DFC or DFG digital force gage.

MTL-110

The MTL-110 can measure force up to 110lbf (500N, 50kgf). This tester is ideal for component testing and its compact design fits small work spaces. The MTL-110 has a 6" (152mm) stroke. The tester's quick-action lever moves the rack and pinion crosshead 3" (76mm) per revolution. The lever may be positioned anywhere along the 20" (508mm) column, and with a 6" (152mm) throat, large samples can be accurately tested. Options include a digital scale for measuring deflection distance. The base adapter adjusts to accommodate different gage models.

MTL-330

The MTL-330 can measure force up to 330lbf (1500N, 150kgf). This tester can be used for tensile and compression testing applications, and is ideal for spring testing. Fit the MTL-330 with a Starrett digital force gage and optional digital scale to determine spring rates, initial tension and more. The MTL-330 can be easily mounted to your workbench for secure testing.

Like the MTL-110, the quick-action lever moves the rack and pinion crosshead 3" (76mm) per revolution. The lever may be positioned anywhere on the 30" (762mm) column, and with a 4" (102mm) throat, large samples can be accurately tested. Optional gage adapter kits are available for use with non-Starrett force gages.

The MTL may be equipped with optional legs so that you can test in a horizontal position.

FEATURES

- Two Capacities: 110lbf, 330lbf (500N, 1500N)
- Compact Design is Ideal for Lean Manufacturing Environments
- Lever-type, Quick-action Crosshead Movement
- Precision Rack and Pinion
- Excellent Position Resolution: Single Rotation for 3" (75mm)
- Adjustable Gage Mounting



MTL - Manual Force Tester, Lever Control

| Model Number | Load Capacity | | | Crosshead Travel | | Resolution/Rotation | | Throat | | Weight | | Thread |
|--------------|---------------|-----|-----|------------------|-----|---------------------|----|--------|-----|--------|-----|------------|
| | N | KGF | LBF | in | mm | in | mm | in | mm | lbs | kgs | mm |
| MTL-110 | 500 | 50 | 110 | 6 | 152 | 3 | 76 | 4 | 102 | 18 | 8.2 | M6, #10-32 |
| MTL-330 | 1500 | 150 | 330 | 6 | 152 | 3 | 76 | 4 | 102 | 20 | 9.1 | M10 |



MANUAL FORCE TESTERS

NEW!

MATERIAL TESTING / FORCE MEASUREMENT

MTH MANUAL TESTERS

The MTH Manual Tester is a single column, manually-operated force tester. The MTH has a load measurement capacity of 550lbf (2500N, 250kgf) and can be used for compression or tensile testing. The mechanical advantage afforded by the MTH-550's precision, high-resolution worm gear design lets you test effortlessly. One rotation of the hand wheel positions the crosshead 0.03" (0.75mm). Total stroke for the MTH-550 is 4" (102mm). Force measurement is performed using a Starrett digital force gage.

The MTH-550 is an ideal, affordable solution for spring testing. Fit the MTH-550 with a digital force gage and optional digital scale to determine spring rates, initial tension and more.

The hand wheel may be positioned anywhere along the 30" (762mm) column, and with a 4" (102mm) throat, large samples can be accurately tested. The base may be permanently affixed to your workbench. Optional gage adapter kits are available for use with non-Starrett force gages. Quick-change clevis adapters let you mount a large selection of Starrett testing fixtures.

FEATURES

- Tension or Compression Testing
- Excellent for Cost-Effective Spring Testing
- Effortless Crosshead Movement
- Precision Worm Gear Design
- Excellent Position Resolution: Single Rotation for 0.03" (0.75mm)
- 30" (762mm) Column Height, 15" (380mm) Working Area
- Adjustable Gage Mounting



The MTH-550 may be equipped with optional legs so that you can test in a horizontal position.

| MTH - Manual Force Tester, Hand Wheel Control | | | | | | | | | | | | |
|---|---------------|-----|-----|------------------|-----|---------------------|------|--------|-----|--------|-----|--------------|
| Model Number | Load Capacity | | | Crosshead Travel | | Resolution/Rotation | | Throat | | Weight | | Thread |
| | N | KGF | LBF | in | mm | in | mm | in | mm | lbs | kgs | mm |
| MTH-550 | 2500 | 250 | 550 | 4 | 102 | 0.03 | 0.75 | 4 | 102 | 22 | 10 | M10 x 1.5-5H |



APPLICATIONS

Adhesives



Important characteristics of adhesives, epoxies and materials that are bonded to one another can be measured using peel testing methods. Pressure-sensitive adhesive properties associated with materials such as labels, packaging products and medical wound management products, can be tested using a 180° testing method.

Biomedical



Testing medical devices and materials used in the production of medical devices are critical to ensure compliance to federal regulations. From the testing of latex products, syringes, stents, catheters to packaging products for medical devices, L3 systems can be used to verify and validate material compliance.

Metals



Metals and alloys are tested under varying conditions. Tensile, compressive, shear, flexural and fracturing properties are important characteristics of all metals and alloys. Modulus, brittleness versus ductility, strength at offset yields are used to characterize these products and their ability to satisfy application and life-cycle requirements.

Building Materials



Materials used in building products, including asphalt and cement-based products can be tested to ascertain their strength and suitability under varying environmental conditions. Compressive and shear properties can be determined using L3 systems.

Composites

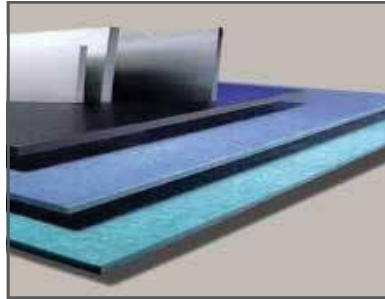

Composites are made by combining two or more materials- often materials with very different properties. Composites based on polymers continue to evolve and find their way into all kinds of products for aerospace and automotive applications to medical applications. Understanding stress and strain characteristics are critical in evaluation composites and their applicability.

Plastics



The growth of plastics and polymers is exponential. Plastics are used everywhere in consumable materials to life-saving medical devices. Plastic properties are important in validating materials used in the development of products comprised of polymers. Tensile, compression, break/rupture/puncture and flexural testing are important characteristics in classifying plastics.

Ceramics



Ceramic and glass products are increasingly be used in a wide variety of products from cellular phones to fibre-optic cables. Because of their inherent brittleness, assessing their mechanical properties are important considerations, both in their design and application.

Textiles



Fabric, yarn, filaments, cords and cloth are tested for strength and durability. Both natural and synthetic textiles are tested for strength and adhesion, tear strength, seam slippage and break strength.

Rubber/Elastomers



Medical gloves, hoses used in automotive and aerospace products, foam, seals and building products are made from rubber and elastomer products. Compression strength, creep strength, puncture strength and tensile strength are important in assessing their suitability and manufacturability.



APPLICATIONS

COMMON TEST METHOD STANDARDS PERFORMED USING L3 SYSTEMS

ASTM TEST METHODS

| | | | | | | |
|-------|-------|-------|-------|-------|-------|-------|
| A370 | C469 | D1876 | D4268 | D7136 | E23 | F2258 |
| A48 | C633 | D1894 | D429 | D7137 | E290 | F2267 |
| A615 | C78 | D2256 | D4632 | D7192 | E399 | F2346 |
| A746 | C880 | D2261 | D5034 | D7269 | E517 | F2412 |
| A938 | C99 | D2444 | D5035 | D790 | E646 | F2458 |
| A996 | D256 | D2844 | D5083 | D882 | E8 | F2477 |
| B557 | D1002 | D3039 | D5250 | D885 | E813 | F2516 |
| C109 | D1004 | D2043 | D5587 | D903 | E9 | F2606 |
| C1550 | D1047 | D3163 | D575 | D905 | F1306 | F382 |
| C1609 | D1238 | D3364 | D5766 | E1012 | F1614 | F384 |
| C165 | D1335 | D3763 | D5930 | E119 | F1714 | F543 |
| C170 | D1414 | D3822 | D6610 | E1290 | F1717 | F606 |
| C192 | D143 | D3835 | D6272 | E18 | F2063 | F88 |
| C297 | D1525 | D3846 | D6319 | E1820 | F2077 | |
| C31 | D1621 | D4018 | D638 | E190 | F2079 | |
| C39 | D1708 | D412 | D648 | E208 | F2255 | |
| C42 | D1761 | D413 | D695 | E21 | F2256 | |

ISO TEST METHODS

| | | | | | | |
|---------|---------|---------|---------|--------|--------|--------|
| 10319 | 13934-2 | 14879 | 2062 | 4587 | 6603-2 | 7800 |
| 11193-1 | 13937-2 | 15630-1 | 20795-1 | 527-1 | 6872 | 7886-1 |
| 11193-2 | 13937-3 | 15630-3 | 20795-2 | 527-2 | 6892-1 | 8067 |
| 1133 | 13937-4 | 16402 | 2307 | 527-3 | 6892-2 | 813 |
| 11339 | 14125 | 17744 | 2411 | 527-4 | 7206-4 | 8256-A |
| 11343 | 14126 | 178 | 306 | 527-5 | 7206-6 | 8295 |
| 11443 | 14129 | 179-1 | 3133 | 604 | 7206-8 | 844 |
| 11897 | 14130 | 179-2 | 3183 | 6238 | 7438 | 9073-4 |
| 12737 | 1421 | 1798 | 34-1 | 6383-1 | 75 | |
| 13007-2 | 148 | 180 | 36 | 6475 | 75-1 | |
| 13934-1 | 14801 | 1926 | 37 | 6603-1 | 75-2 | |

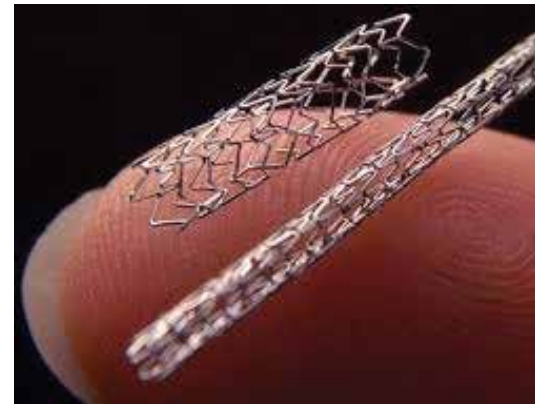

APPLICATIONS

WE KNOW FORCE ANALYSIS AND MEASUREMENT

Tensile testing



Identifying tensile force characteristics such as peak load is critical in validating a product's safety and application. Whether its consumer products, medical products, packaging materials or fasteners used in the building trades, tensile testing is a fundamental measurement available on all Lx systems.

Shear testing



Shear tests help measure the deformable mechanical properties of cosmetics, plastics, composites, fluids and other samples. Lap shear testing can be used to measure mechanical weld strength or the adhesive strength of epoxies.

Peel testing



Adhesive strength properties are measured to understand the bonding capabilities of coatings and glues on various types of materials- from paper to substrates to building materials. Both 90° and 180° testing can be performed to measure the peak holding strengths under standard test methods such as ASTM F88.

Compressive testing



Compressive loads are important in evaluating packaging designs, such as top load testing. Core sampling of concrete-based products are measured to determine their strength. And springs are analyzed under load to determine spring rate based on free length.

Flexural testing



Flexural strength and material stiffness represent the combined effects of a sample's basic tensile, compressive and shear characteristics. Composites, wood products, paper products can be tested in both 3- and 4-point methods to determine their stiffness and resilience.

Coefficient of friction testing



ASTM D1894 is a common test method for measuring coefficient of friction. Materials such as plastic sheeting can be tested to measure both the static and kinetic frictional characteristics. Other materials, such as flooring products are tested to determine their slip resistance and safety under various environmental conditions.

Break, Fracture and Rupture testing



Destructive testing can involve tensile, compressive, shear and other test methods where the product is tested to failure. Often this testing is used to determine the "peak" measurements that occur prior to the break event. Lx system allow you to measure precisely based on stress, strain, load, displacement and time.

Load rate testing



Load rate testing is a more complex testing method compared to testing to a setpoint at a specific velocity. Load rate testing can be used on consumer products, such as children's attire, to measure the pull strength of buttons and their resistance to breaking loads. Here the button is pulled at a rate (lbf/minute) rather than a time velocity (in/min).

Contact closure testing

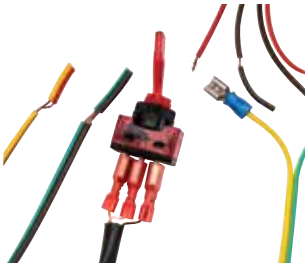

Using the optional Automation Builder, the "make and break" load for an electrical switch can be measured precisely. Load is applied to the switch and the peak load is measured when the switch closes/opens. This type of application can be tested on keypads, membranes and other materials that utilize a resistance change.

Insertion/Extraction testing



Insertion/extraction testing is performed on electronic components like jacks, medical devices, consumer products, and more. The loads are measured in both directions- tensile and compressive to determine the sample's characterization for the application and for product life-cycle determination.

Creep and Relaxation testing



Foam is a material where its deformation while under an applied load below its yield strength is measured and analyzed. Knowing the material's ability to maintain its specified deformation is important for comfort and longevity in its intended application.

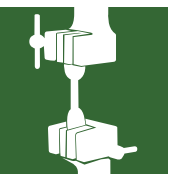

APPLICATIONS

PACKAGING TESTING

T-Peel
90° Peel
180° Peel
Solder Paste Tackiness
ASTM F1140 - Burst Strength
ASTM D2659 - Top Load
ASTM F88 - Seal Strength
EN 868-5 - Seal Strength Pouches
ASTM C633 -Adhesion Spray Coating
ASTM D1335 - Tuft Binding Floor Covering
ASTM D903 - Adhesive Bond
ASTM D1876 - Peel Resistance
ISO 36 - Rubber Adhesion
ISO 2411 - Adhesion Plastic
ISO 4587 - Lap Shear Strength
ISO 11339 - Flexible Bond Assembly
EN 1465 - Lap Shear Strength
EN 1719 - Tack Measurement
EN 1939 - Peel Adhesion
Component Testing
Compress (Load/Extension)
Compress (Stress/Strain)
Indentation (Load/Extension)
Indentation (Stress/Strain)
Spring Rate
Spring Force
Spring Height

MEDICAL DEVICE TESTING

ASTM F88 - Seal Strength
ASTM F382 - Metallic Bone Plates
ASTM F451 - Bone Cement Strength
ASTM F564 - Metallic Bone Staples
ASTM F1828 - Ureteral Stents
ASTM F1839 - Foam Devices
ASTM F1874 - Sutures Bend Test
ASTM F2079 - Stents Tensile Strength
ASTM F2132 - Puncture Resistance
ASTM F2183 - Punch Testing
ASTM F2255 - Lap Shear Testing
ASTM F2256 - Tissue Adhesives
ASTM F2258 - Tissue Adhesives
ASTM F2392 - Burst Strength Sealant
ASTM F2458 - Closure Strength
ASTM F2477 - Stents Strength
ASTM F2502 - Plates and Screws
ASTM F2516 - Tensile Nitinol Wire
ASTM F2606 - Bend Vascular Stent
ASTM D6319 - Medical Gloves
BS EN 455-2 - Medical Gloves
ISO 7886-1 - Hypodermic Syringe
ISO 14879 - Tibial Trays
ISO 11193 - Medical Glove

COMPRESSION TEST

Tensile Test
Tensile Strength
ASTM D3039 - Tensile Carbon Fiber
ASTM D3846 - Shear Strength
ASTM D7269 - Aramid Cords
ASTM D6484 - Compressive Strength
ASTM D1055 - Flex Resistance
ASTM D3574 - Indention Deflection
ASTM D3574 - Foam Deflection
EN 14509 - Shear Strength
ISO 527-4 - Tensile Isotropic/Orthotropic
ISO 14125 - Flexural Properties
ISO 14126 - In-plane Compression
TAPPI - 404 - Tensile Break Strength
TAPPI 220 - Burst Strength
TAPPI 456 - Wet Paper Strength
TAPPI 457 - Pull to Rupture



SERVICES

CALIBRATION, FIELD SERVICE, FACTORY SERVICE

We can provide all levels of service for your material test and force measurement systems. We can supply a comprehensive range of calibration and verification services to ensure that your testing meets the requirements of international testing standards. Calibrations can be performed to ASTM E4 for load and ASTM E2658 for displacement or to equivalent standards from ISO, BS, DIN and more. Speed, stress and strain verifications can be performed on-site by technicians accredited to ISO 17025.

Preventative maintenance programs, field and factory repair services are available to ensure that your systems perform to their published specifications.

Starrett can provide factory services including load cell calibrations, test frame repair and reconditioning. All Starrett load cell sensors are supplied with a NIST-traceable Certificate of Calibration.

Specialized services, including system integration with existing instrumentation, or application development for complex testing applications can be supplied by your Starrett representative.

Your Starrett representative can provide on-site training to your personnel to help ensure that your system operates to its published specification. Our training also provides your operators with the knowledge needed to perform your testing in a safe and efficient manner. Our objectives are to help you make your products better through improved resource utilization, increased throughput and optimized efficiency.



Starrett stocks critical spare parts and accessories for quick delivery. Load cell sensors and commonly used test fixtures are readily available.



Field and factory calibrations are performed by authorized Starrett service technicians to accepted industry standards and methodology. All calibrations are NIST-traceable.





LASER MEASUREMENT

NEW!

LASER MEASUREMENT

LASER MEASUREMENT

Profile360 is an in-line, real-time, non-contact measurement system for continuously monitoring key profile dimensions in complex shapes such as rubber, ceramic, plastic, and wood-plastic composite extrusions, roll-formed metal profiles, and profiled wire. Profile360 employs CrossCheck™ Line Laser Sensors to digitize the profile, compare it to a CAD template, and continuously monitor key dimensions. Dimensional changes often indicate a change in material, equipment, or process, resulting in poor quality or high scrap or reclaim cost.

Profile360 continuously monitors the size and shape of complex profiles in order to assure quality and avoid the high cost of defects. The system acquires thousands of data points around the profile and matches them to a CAD template, where key measurement parameters such as width, thickness, gap, radius, and angle are extracted. Measurement parameters are compared to allowable control limits and displayed on the operator's terminal with a pass/caution/fail status indicator. Profile360 runs at rates up to 20 profiles per second. The system is available in standard sizes and can be custom-built for almost any size and shape.

IN-LINE MONITORING IS DISPLACING OFF-LINE CHECKING METHODS:

- Alarms immediately when the dimensions change so that operators can intervene to correct the process, resulting in improved quality, improved production yield, and reduced cost of scrap and rework
- Provides instant measurements, so the operator can immediately see the results of all line adjustments
- Provides 100% inspection of the entire run compared to periodic off-line checking, which can miss many disturbances
- Used by many to decrease start-up time, resulting in higher production yield and lower scrap cost



THE PROFILE360™

Unlike oscillating measurement systems, Profile360 has no moving parts – no slides, motors, controllers, or encoders to require maintenance and calibration. The system is sealed and temperature controlled to assure a constant internal temperature. This results in a greatly reduced thermal drift for the system and assures a long laser diode life, even in tough environments.



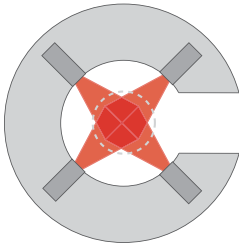

C-FRAME SYSTEMS

- Available in 10, 30, 50, 75, 100, and 175mm diameter fields-of-view
- Available in 2, 3, 4, 5, or 6 sensor configurations
- Available with the Industrial Mobility Package, which includes: Mobile lift cart, Industrial PC, Industrial Touchscreen monitor, UPS, PLC, and light stack, assembled into an "all-in-one" package

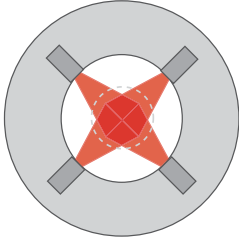

O-FRAME SYSTEMS

- Available in 300, 600, and larger fields-of-view
- Available in 2, 3, 4, 5, 6, 7, or 8 sensor configurations
- Custom sizes and configurations also available

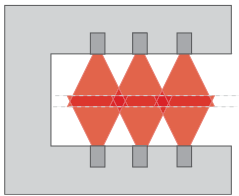

TWO-SIDED SYSTEMS

- Available using any sensor size, in overlapping and non-overlapping sensor orientations

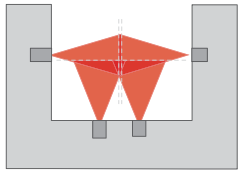

THREE-SIDED SYSTEMS

- Available using any size sensor, in overlapping and non-overlapping sensor orientations

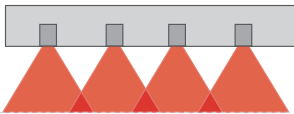

SINGLE-SIDED SYSTEMS

- Available using any sensor size, in overlapping and non-overlapping sensor orientations



INSPECTING WITH THE PROFILE360™

- Line Operators can immediately observe and react to manufacturing problems
- Production Managers can quickly review historical run data
- Quality Control Managers can better understand the process and factors that cause variation

ADDITIONAL BENEFITS INCLUDE

- Faster startups, faster product development, faster die design
- Improve customer satisfaction
- Reduce inspection labor and material scrap



AUTO SEALS

When auto sealing extrusion lines go out of specification, they produce about \$1,400 per hour in scrap. The scrap is not recyclable because the rubber is vulcanized, and often is cured over metal reinforcement. The result is a loss in raw materials, labor, energy, landfill cost, and production time.

Profile360 alarms any time dimensions change so the operator can act to correct the process, save scrap, and improve production. The Profile360 investment payback period is achieved in only 32 hours of scrap savings. If you can avoid 1 hour's worth of scrap per week, your Profile360 investment is realized in 32 weeks.

Savings with Profile360™*

| | | |
|-----------------------|---------------------------------|-----------------|
| Compound Cost | | \$1.32/meter |
| Line Speed | | 18.2 meters/min |
| Compound Cost/hr | 18.2m/min x 60min/hr x \$1.32/m | \$1,441/hr |
| Profile360 Investment | | \$42,900 |
| Payback Period | \$42,900 ÷ \$1,441/hr | 32 hours |

* If you can reduce scrap by 1 hour per week, you can achieve a payback in 32 weeks based on raw materials cost avoidance alone, not to mention the cost of customer returns.

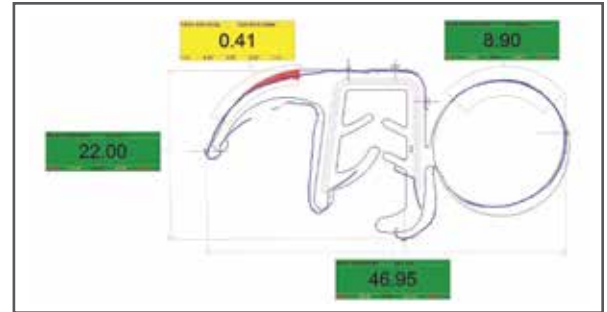
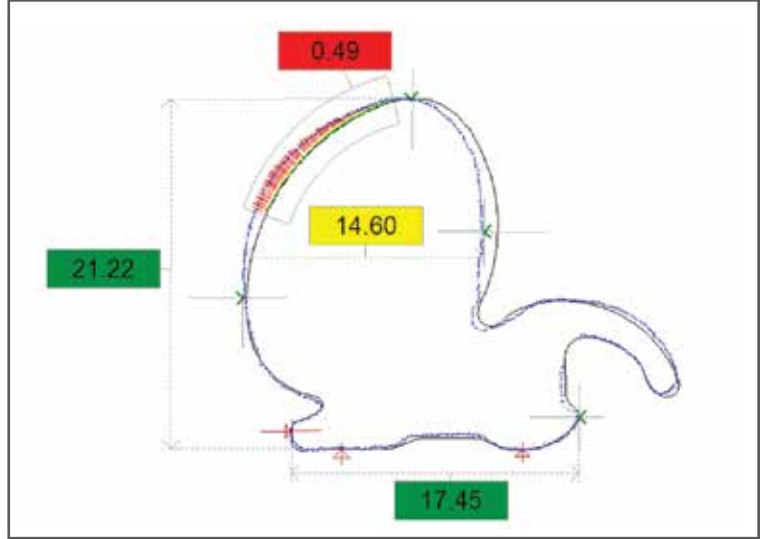

EXTRUDED WINDOW PROFILES

PVC profiles can distort during calibration and cooling, resulting in non-usable profiles.

In-line checking with Profile360™ assures that the operator will be alerted any time there is a change in size, shape, or squareness. This helps reduce the time and cost of rework and improves yield.

Since Profile360 provides real-time measurement, there is no need to cut samples, de-burr the cut edges, and walk to a central off-line inspection station in order to check dimensions. Profile360 greatly reduces the cost of dimension checking, and provides a much faster result.

FEATURES

- Monitor angles, squareness, gaps, grooves, and other key dimensions in real-time with on-screen optical comparator and trend graph displays
- Alarm when dimensions change
- View real-time profile geometry from any PC on your network
- Report complete dimensional statistics for each run

Which of These is the Most Efficient Way to Start Up Your Extrusion Line?

| Profile360™ | Off Line Methods |
|---|--|
| View Real-Time Profile Dimensions In-Line | Cut Part |
| Adjust Extruder Immediately | Walk to Metrology Lab |
| Allow Adjustment to Stabilize and Pass Through Profile360 | Cut Sliver |
| Repeat | Clean and Prep Sliver |
| Time Required: 5 min per adjustment | Put Sliver in Queue for Measurement |
| | Upload File/Find Mylar |
| | Place Sample On Scanner/10x |
| | Complete Measurement Routine |
| | Print Report |
| | File Report |
| | Walk Back to Extruder |
| | Adjust Extruder |
| | Wait for Adjustment to Stabilize |
| | Repeat Entire Process |
| | Time Required: 30 to 60 min per adjustment |

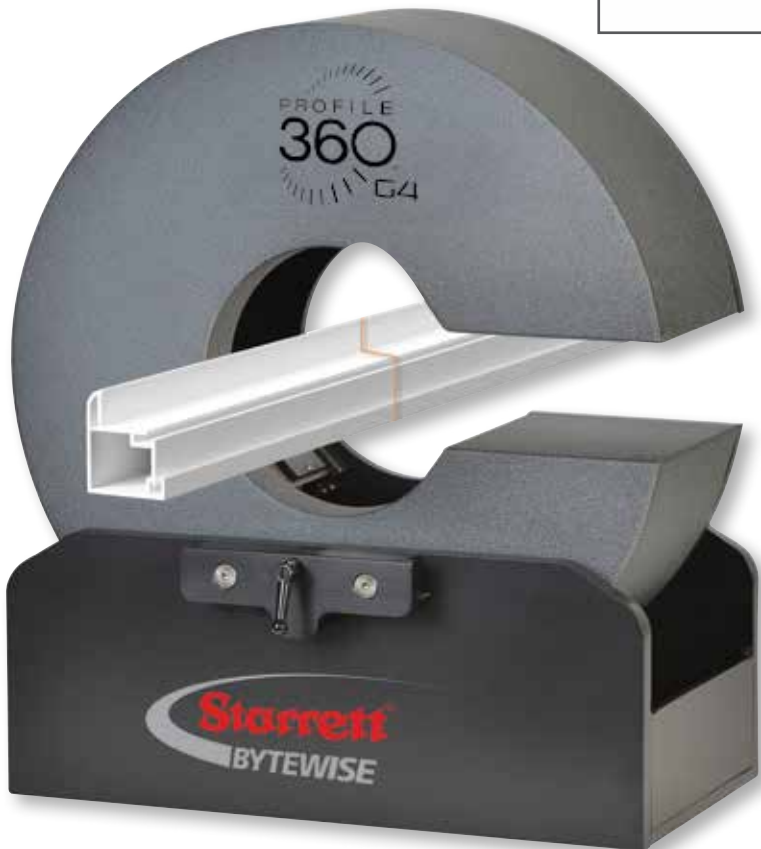
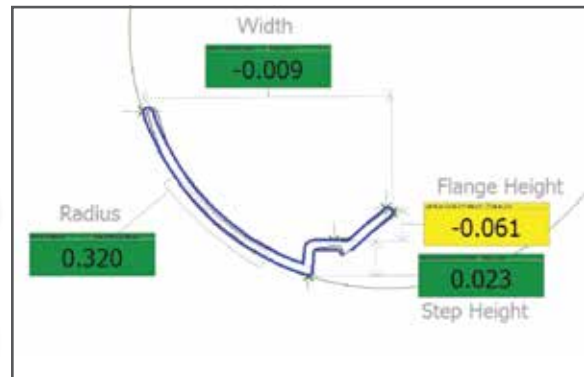
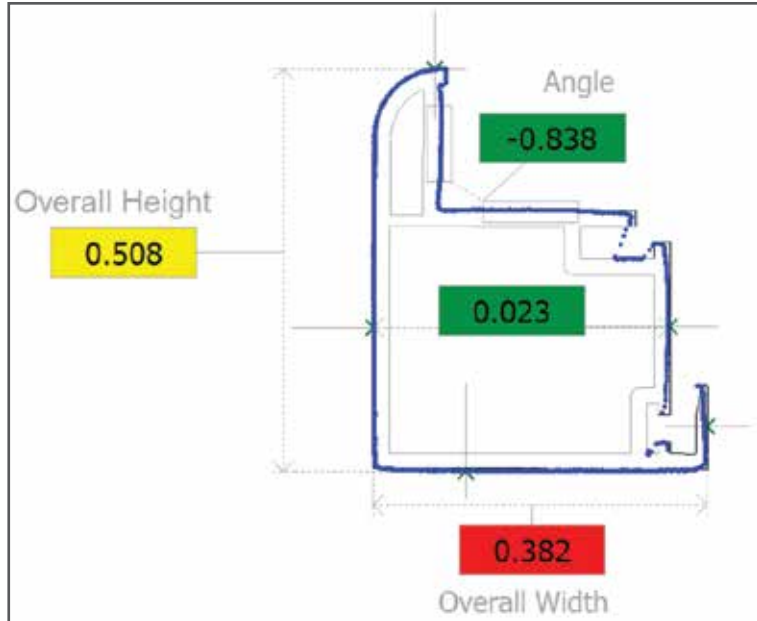

WOOD-PLASTIC COMPOSITE

Wood-plastic composites have variations in raw material properties, humidity, and barrel temperature, and these variations can result in profiles that swell or sag, resulting in defective boards. Profile360™ is employed to continuously monitor profiles coming out of the die to assure the process is under control and the size and shape is correct. Profile360™ can measure boards to the lower end of the allowable tolerance range in order to reduce the raw material cost per board, resulting in payback within 100 days.

Cost Savings

| | |
|-----------------------|--------------------------|
| Nominal Board Size | 5.5in ² |
| Target Area Reduction | .1in ² (1.8%) |
| Material Cost | \$.60/lb |
| Density | .04lb/in ³ |
| Line Speed | 144in/min |
| Target Savings | 14.4in ³ /min |
| Cost Savings | \$477/day |
| Payback Period | 100 days |

FEATURES

- Monitor tongue and groove dimensions, squareness, flatness, embossing depth, and other key dimensions in real-time with on-screen optical comparator and trend graph displays
- Run near lower spec limit to reduce raw material costs

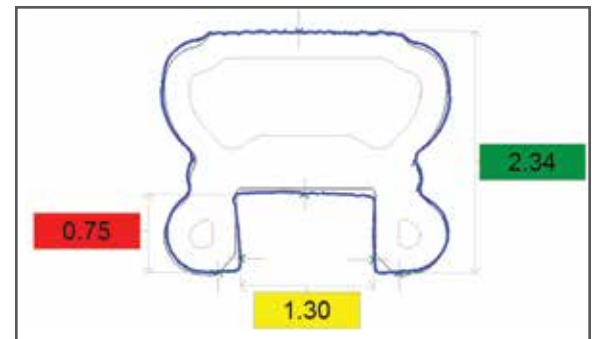
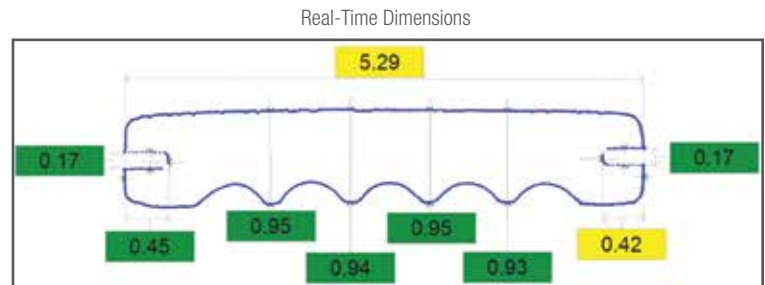
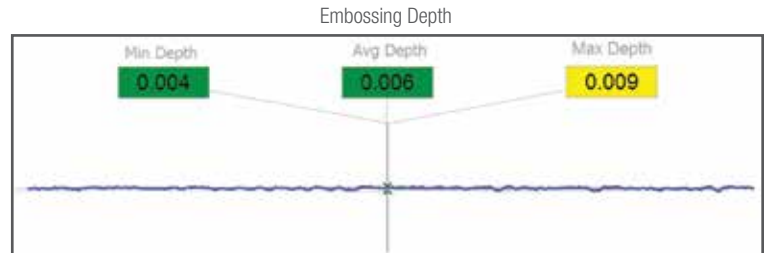

ROLL FORMING

Roll-formed profiles often go out of specification during a run because the incoming coils have lot-to-lot variations in width, thickness, crown, camber, and physical properties. Manual inspection is a time-consuming method to isolate out-of-specification material, resulting in bad parts produced on long runs.

FEATURES

- Monitor key dimensions in-line for changes due to coil thickness, crown, camber, and physical properties
- Reduce or eliminate costly and time-consuming off-line checking
- Make faster set-ups by checking each pass on-line

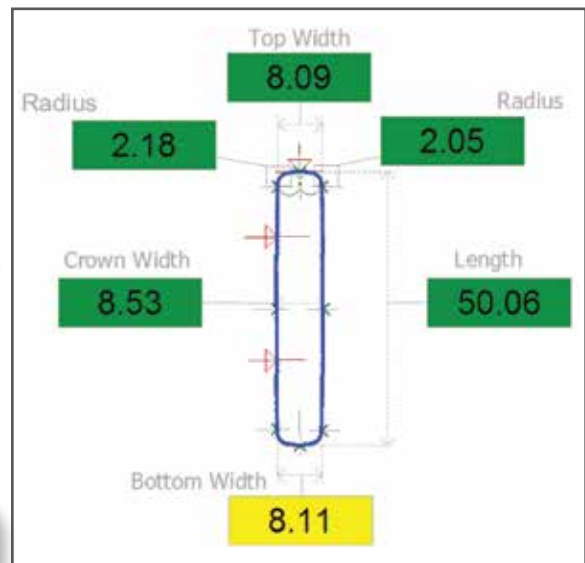
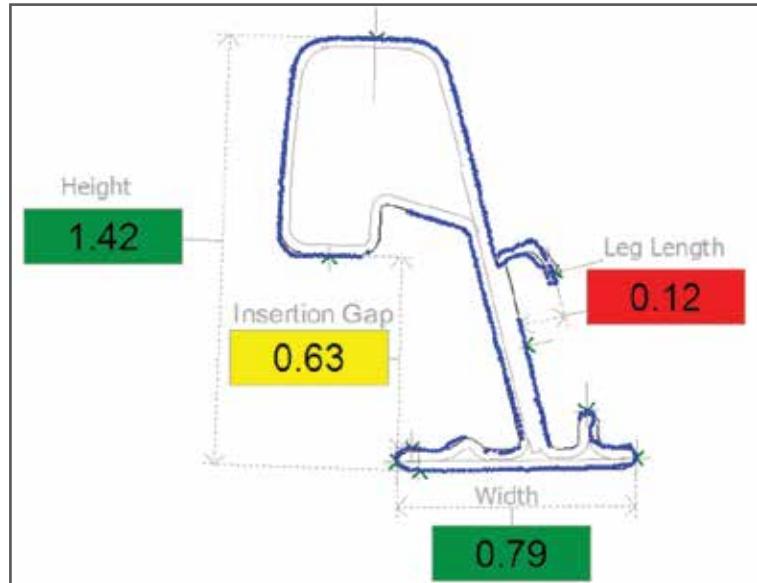

PIPE, OD, OUT OF ROUND AND LENGTH MEASUREMENT

PROFILE360™ MEASURES OUTER DIAMETER AND OUT OF ROUNDNESS OF A PIPE BOTH IN-LINE (ON THE MILL) AND IN FINAL INSPECTION.

When used in final inspection, Profile360 produces an automated dimensional inspection report for the Outside Diameter (OD) and Out of Roundness (OOR) of the pipe ends and body to assure compliance with API and other standards. When installed prior to cutting, the measurements can be used to fine-tune the tooling during a set up change, and then alarm whenever OD or OOR values approach the allowable limits so that an operator can intervene before a quality fault occurs.

PROFILE360 UTILIZES CROSSCHECK™ LINE-LASER SENSORS, DEVELOPED AND OPTIMIZED BY STARRETT-BYTEWISE TO ACHIEVE THE RANGE AND ACCURACY REQUIRED FOR PIPE MILLS.

Sensors are mounted on a precision frame and aligned via patented software techniques. Data sets from each sensor are internally transformed into a global coordinate system to render the complete cross-sectional profile image.

| 2 Position | Max Diameter Tol | Max Diameter Tol | Max Diameter | Avg Diameter | Min Diameter | OOD Tol | OOR | Classification |
|------------|------------------|------------------|--------------|--------------|--------------|---------|-----|----------------|
| 1 | 396.21 | 396.21 | 396.21 | 396.51 | 393.94 | 4.27 | | Pass |
| 2 | 396.21 | 396.21 | 396.21 | 396.51 | 393.94 | 4.27 | | Pass |

A SINGLE MEASUREMENT CYCLE INSTANTANEOUSLY ACQUIRES THOUSANDS OF DATA POINTS IN A PRECISE CROSS-SECTIONAL PLANE IN A MATTER OF MILLISECONDS.

Software measurement tools can be configured to display and record up to 180 OD values, one per degree, as well as maximum and minimum OD and OOR for the pipe ends and body.

PROFILE360 IS INHERENTLY RELIABLE DUE TO ITS SIMPLE DESIGN.

Unlike oscillating measurement systems, Profile360 has no moving parts – no slides, motors, controllers, or encoders to require maintenance and calibration. The system is sealed and temperature controlled to assure a constant internal temperature. This results in a greatly reduced thermal drift for the system and assures

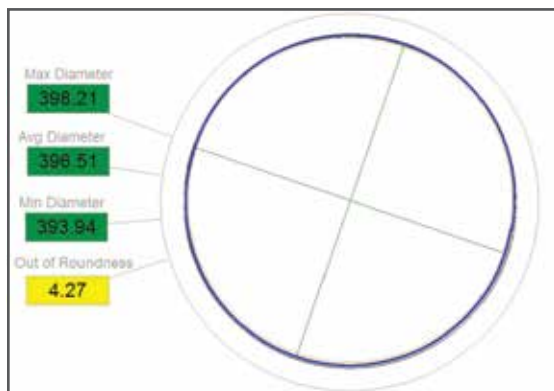

WIRE AND CABLE

Multi-conductor cables, sub-sea cables, and fiber optic cables rely on the cover extrusion to isolate the conductors from the environment to assure safe and reliable power and data transmission. Profile360™ is employed on the line for 100% inspection of the cover geometry.

Profile360 is also used to monitor shaped wire profiles such as magnet wire for size and shape uniformity.

FEATURES

- Monitor key dimensions on-line, in real-time, for changes due to material size variations, tooling breakage and wear, spindle alignment, and process control
- Reduce or eliminate costly and time-consuming off-line checking
- Make faster set-ups

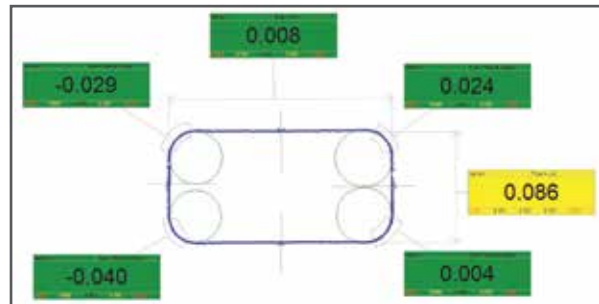
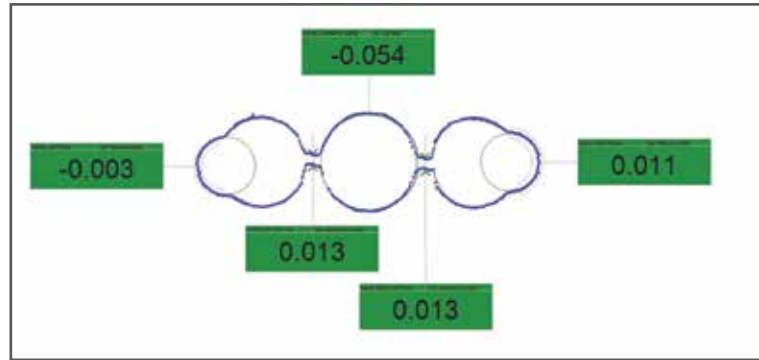

TECHNICAL SPECIFICATIONS

| Parameter | Capability |
|---|--|
| Accuracy ¹ | 0.045% of FOV (Field of View) |
| Static Repeatability ² | <0.03% of FOV |
| Thermal Stability ³ | < 0.03% of FOV/deg C |
| Warm-up Period ⁴ | 10 minutes |
| Measurement Frequency (Framerate) ⁵ | Up to 20 Hz |
| Outputs | 24 VDC Relay Outputs; 0~10VDC Analog Output; others available upon request |
| External Communication/Interface | Modbus TCP; OPC Server; API provided; other protocols available upon request |
| Data Storage | Relational Database, .txt file |
| Measurement Triggering | Clock frequency (Time-based); Encoder (length-based); Digital Signal |
| Laser Class | IEC 60825-1 Class 3R |
| Power Requirements | 110~240 VAC, 5A |
| Operating Temperature ⁶ | 0°~45°C (32°~113°F) |
| Humidity | 0~95% Non-Condensing |
| Sensor Communication Platform | Ethernet |
| PC Operating System | Windows® 10/7 (32- or 64-bit) |
| Max. Dimensions and Weight: 30, 50, 75 and 100mm FOV Systems (1", 2", 3" and 4" FOV Systems) | 550 (H) x 525 (W) x 290mm (D); 30kg [21.7 (H) x 20.7 (W) x 15.2" (D); 55lbs] 313mm (12.3") from mounting surface to center of FOV |
| Max. Dimensions and Weight: 175mm FOV Systems (6" FOV Systems) | 885 (H) x 770 (W) x 385mm (D); 53kg [34.8 (H) x 30.3 (W) x 15.2" (D); 115lbs] 500mm (19.7") from mounting surface to center of FOV |

1. Accuracy is representative of the system's error in measuring a known value. It is expressed as the Bias in a series of measurements of a certified gage block.
2. Repeatability is representative of the system's ability to monitor process variation. It is expressed as the three-sigma standard deviation in a series of measurements of a known gage block. (Repeatability and Accuracy are based on 2012 standardized test procedure. Field results may be better or worse depending on caliper type, size, and placement. This is the variation taken over a short time period in a room temperature environment, for a product that is static in the field of view.
3. This is the amount of measurement variation that might be observed for each degree change in ambient temperature.
4. This is the minimum amount of time that should be allowed for the system to reach measurement stability.
5. A measure of profiles scanned per second. Max framerate may vary depending on number of sensors in system and PC specifications.
6. Please note that process-related heat can affect the ambient temperature around the sensors. An optional cooling system can be provided in environments where the sensor temperature approaches or exceeds the stated limits

INDUSTRIAL MOBILITY PACKAGE

The Profile360™ Industrial Mobility Package has been employed by large extrusion operations during line set-up so that one unit can serve multiple lines. The in-line measurement provides instant information to help the operator tune-in the extruder, calibrator, and down-stream equipment, and to assure all dimensions are stable before moving on to the next line.



Industrial Mobility Package with C-Frame System



SOFTWARE

PROFILE360™ SOFTWARE PROVIDES:

- Matching and comparison of measured profile to a CAD template.
- Caliper-based utilities to program each profile design for specific measurements.
- Storage of design library on local or networked drive.
- Display of all real-time measurement data.
- Display of trend data.
- Data logging for all measurement results.
- Standard report printing.
- Software can be installed on any network PC and connected to the instrument to view the real-time data.

| Software Features | | | |
|-------------------|---|---------------------------|---|
| Data Matching | Match profile to CAD template Anchor profile to multiple datums Match to user-defined sub-regions Match multiple profiles independently | Available Measurements | Thickness Width/Height Angle Area Radius Diameter (Max, Min, Avg) Ovality Circumference Distance to point in space Distance to specific feature (such as a groove in the profile) Distance of any surface from its nominal/theoretical position |
| Display | Measured values with pass/fail/warning status Error from nominal Cp and Cpk Standard deviation Trend charts Histograms Overlay of measured profile onto CAD template Error vectors to show differences from CAD template Averaged or median-filtered values over specified time | | Registration Quick recalibration to certified gage pins |
| Report Writer | Charts List Exceptions summary Start and end times of run | Data Logging | Log caliper values to history file Save point cloud to .txt Save SnapShots to history file |
| | | External Device Interface | OPC Server Modbus TCP client |

Starrett-Bytewise is excited to announce that we have partnered with Inductive Automation, developers of the Ignition® platform, to provide many enhancements to our own Profile360 software. Ignition provides the ability to create custom HMIs, reports, and view real-time or historical measurement data. Ignition also saves data from the Profile360 software to an ODBC compliant database. The use of Ignition further unlocks the potential of the Industrial Internet of Things (IIoT) and Industry 4.0 applications

Version 3.0 with Ignition® offers several options to meet the data needs of our customers. The Basic Package includes screens to visualize:

- Real-time and historical trend charts by run
- Alarm charts and alarm summaries for your out-of-spec conditions
- Data logs with summary statistics for each run
- List of runs filtered by run number or time

You may also choose to upgrade your package with add-on modules for:

- SPC Charts and Statistics
- Alarm Notification by Email
- Advanced Reporting Capabilities providing flexibility in format, triggers, and distribution of reports
- Mobile Access from a phone or tablet



TIRE INDUSTRY

GUIDE TO TECHNOLOGY

At Starrett-Bytewise, we employ three types of sensor technologies: fixed point laser, displacement sensors, CrossCheck low-speed laser line sensors, and CrossCheckHD high-speed laser line sensors. All laser line sensors are designed and built by Starrett-Bytewise.

CrossCheck Sensors project a laser line across a profile, digitize the image, and transform the image into a geometric coordinate system. Multi-sensor systems acquire thousands of data points around the profile and match them to a CAD template, where key measurement parameters are extracted.

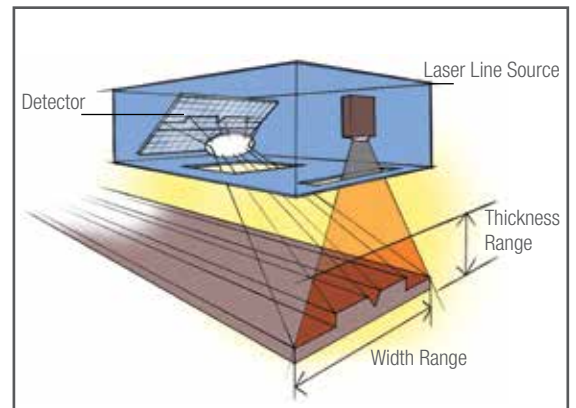

Component Preparation

Tread and Sidewall Extrusion

On-Line Profilometer
Off-Line Profilometer
Profilometer 3D
Off-Line Profilometer SL

Calendar

Gum Calendar Monitor
Overlapping Ply Splice Monitor
CrossCheck Width

Apex Extrusion

Profile360™ On-Line Profile Measurement System

Tire Building

Carcass Drum

Overlapping Inner Liner and Body Ply Splice Monitor
GTU Diagnostic System

Belt/Tread Drum

CrossCheck Belt Edge and Dog-Ear Splice Monitor
GTU Diagnostic System

Shaping Drum

GTU Radial Runout and Lateral Runout Monitor
GTU Diagnostic System

Tire Development and Testing

Tread Wear

Tire360
CTWIST - Circumferential Tread Wear Imaging System

Tire Profile

Bead-to-Bead Tire Profile Measurement System

Sidewall Profile

GEO-360



CrossCheck

CrossCheck™ SPECIAL APPLICATIONS

Easy to use CrossCheck "shape tools" measure radius/diameter, height, width, angle, and location. Master Profile Comparison provides Pass/Fail testing for contours, and makes small variations easily visible. All for less than the price of a single point laser sensor. CrossCheck is ideal for OEMs who need a fully designed, calibrated, and environmentally sealed 3D laser machine vision solution.

- CrossCheck's affordability and simplicity bring profile measurement to the entire organization
- R&D: Reverse Engineering
- Engineering: Design Validation
- Production: Monitor and control
- Quality: Process Studies
- Maintenance: Set Up and Adjustment



ON-LINE PROFILOMETER (OLP)

Tread profile geometry has a strong influence on the cured tire uniformity. Treads that are non-symmetrical produce cured tires with uniformity and balance problems. Over-sized treads are a waste of materials. In order to assure the most precise tread and sidewall extrusion quality, tire makers worldwide have adopted the On-Line Profilometer (OLP) as their standard for extrusion monitoring. The On-Line Profilometer (OLP) provides automatic, high speed, non-contact measurement of tread and sidewall extrusions. OLP outperforms scanning systems by collecting an instantaneous cross-section profile rather than measuring in a zigzag pattern.

OLP can be installed after the die exit to monitor and alarm when key dimensions exceed the allowable tolerances. Dimension changes at the die often indicate changes in rubber visco-elastic properties or changes in the equipment set-up. When dimensions change, the operator is alerted to intervene. Early intervention can lead to faster startup, reduced rework, better production rates, and better tread uniformity.

OLP can also be installed after cooling to make 100% quality inspection of all treads before they are released to the tire building operation. This enables the QC organization to compare the current run to the historical standards, to pass or fail each run, and to maintain an audit trail for each lot.

USES

- Use OLP at the die during the startup of any run to assist in reducing the time required to reach stability
- Use OLP at the die to continuously monitor the dimensional quality of any profile, and alarm the operator when any problem occurs
- Use OLP at the die to immediately recognize changes in die swell associated with batch change so that the operator can adjust the extruder settings
- Use OLP after cooling to produce data histories to compare any run with its historical performance and verify the effect of quality improvement initiatives
- Use OLP after cooling to check for die wear
- Use OLP data alongside other process data such as material theology, extruder die head pressure, screw RPM, screw power, and various temperatures to develop better knowledge of the complex interactions between materials, process set-points, and profile geometry



OLP

| Specifications | Measurement Range | | | | | | | |
|---------------------------------|--|-------|-------|-------|----------------|------------|------|------|
| | Thickness (in) | | | | Width (in) | | | |
| | 2.36 | 11.81 | 17.72 | 23.62 | Thickness (mm) | Width (mm) | | |
| | | | | | 60 | 300 | 450 | 600 |
| Absolute Accuracy ¹ | .003 | .012 | .012 | .012 | ±0.075 | 0.30 | 0.30 | 0.30 |
| Relative Accuracy ² | .001 | .004 | .004 | .004 | 0.0225 | 0.09 | 0.09 | 0.09 |
| Gage Repeatability ³ | .001" (0.025mm) | | | | | | | |
| Resolution ⁴ | .00004" (0.001 mm) | | | | | | | |
| Measurement Rate | Selectable up to 7.5 profiles/second | | | | | | | |
| Outputs | Analog and Digital I/O; Ethernet (Modbus TCP, Text over TCP); tab-delimited .txt measure log | | | | | | | |
| Laser Classification | IIIa CDRH, 3R IEC | | | | | | | |

1. Absolute Accuracy: The average error of all dimensions of a certified gage block using the mean of 75 consecutive measurements. Error is defined as the difference between the OLP measured value and the certified target value.
 2. Relative Accuracy: The maximum amount of error present when comparing successive measurements of a target with changing dimensions and located at a fixed position within the field of view (This also can be considered as "accuracy in measuring product variation."
 3. Gage Repeatability: An offline assessment calculating the standard deviation of the thickness of a certified gage block over 75 measurements.
 4. Resolution: The smallest meaningful unit of measurement that is reported by the system.



OFF-LINE PROFILOMETER 3D (3DP)

The Profilometer3D is the third-generation offline Profilometer from Starrett-Bytewise, and comes after 20 years of product experience. Profilometer3D is used to verify the accuracy of newly-cut dies by checking the extrusion dimensions. Its accuracy and speed helps reduce the number of die trials needed to approve a new die for production. Once the die is in production, Profilometer3D is used to check each run for overall quality, and to monitor for die wear. Under ideal conditions it is favorable to run tread extrusions so that the three main parameters – thickness, width and weight, are as near as possible to the lower control limits. This reduces the cost of the compound consumed. In practice extrusion lines normally operate with some if not all parameters above the limits. Since the tread measurements are used to tune the die dimensions, reductions to measurement uncertainty directly relate to improved die accuracy, which translates into less "running heavy".

Profilometer3D is built on a monolithic granite superstructure in the "Academy Black" granite fabricated by Starrett Tru-Stone Technologies. This granite was selected due to its excellent properties for machinability, flatness, and coefficient of thermal expansion. Sensors are mounted to servo-motor controlled traversing slides mounted top and bottom. Linear travel is encoded to 5µm intervals. Profilometer3D is positioned on a wheel cart with locking casters.



| Parameter | µm |
|--|-----|
| Thickness Error of Measure (bias + 3σ) | 25 |
| Thickness Bias (typical) | 15 |
| Thickness Repeatability (typical) 1σ | 3.3 |
| Width Error of Measure (bias + 3σ) | 250 |
| Width Bias (typical) | 100 |
| Width Repeatability (typical) 1σ | 50 |

MEASUREMENT CAPABILITY

No measurement system is exact, and all measurement systems have some degree of uncertainty, or error. We characterize measurement uncertainty by the Error of Measure method (EoM). EoM characterizes the inherent variation or capability of the equipment itself without regard to contributions from external sources. EoM is a means to express the capability of the measurement system that includes both the bias and repeatability components of variation. EoM encompasses the 99% confidence interval.

Error of Measure (EoM) is representative of the system's error in measuring a known value. It is calculated as the absolute value of the Bias plus 3σ for the measurement series. EoM is reported as two values - one for thickness and one for width.

Bias is the average error from the known value. It is calculated as the absolute value of the average measurement minus the known value.

Repeatability is representative of the system's ability to monitor process variation. It is calculated as the range (maximum minus minimum) divided by 6, and expressed as the 1-sigma standard deviation of the measurement series.

Even if the measurement uncertainty is zero, there is measurand uncertainty – the uncertainty in how well the sample measured represents the overall tread. As measurement uncertainty approaches zero, the measurand uncertainty can become the main source of variation. Profilometer3D acquires 512 tracks across 25mm width. This permits one to assess an area wide enough to average out variations and edge artifacts, something that can't be done with a single track area of interest.

SENSOR TECHNOLOGY

Profilometer3D utilizes CrossCheck2T line laser sensors. These sensors project a laser line across the tread, and view the laser line with two CMOS cameras, one each side of the laser line. The resulting images are transformed into dimensional coordinates using triangulation methods. The two images are combined so that any data lost due to triangulation blockage of one camera can be augmented by data from the other camera. CrossCheck2T sensors employ high-speed CMOS detectors that run at frequencies 1,000 Hz and higher. The Starrett-Bytewise CMOS-based sensors were introduced in 2002 and there are over 3,000 sensors in use.

SELF-CALIBRATION

A multi-step certified gage block is mounted at the start position. At the beginning of each scan the gage block is measured. If the gage block measurements are inside the allowable range the measurement cycle is executed using the current calibration values. If the gage block measurement is outside the allowable tolerance the calibration offset is automatically adjusted. This means that the system is self-calibrating. This self-calibration compensates for error due primarily to temperature change in the environment. The gage block spans the entire width of the laser line. The calibration adjustments can be set to update automatically or to prompt the user to accept the changes. We log all calibration changes along with the temperature in the top and bottom chambers.



OFF-LINE PROFILOMETER (OFLP)

Tread and sidewall extrusions can be no more precise than the dies used to make them. When a new die is cut it should be well-centered, so the Operator has the flexibility to optimize the extruder set-up. After some time in service, die wear can be uneven so that certain areas along the profile get excessive rubber flow. This is a very costly waste of raw materials. Unbalanced flow can also disrupt the symmetry of the tread - a factor that influences cured tire uniformity and balance.

The Profilometer was developed as an automated, non-contact measurement system to displace checking with hand tools. The Profilometer is used to verify the accuracy of newly-cut dies. Its accuracy and speed helps reduce the number of die trials needed to approve a new die for production. Once in production, the Profilometer is used to check each run for overall quality, and to monitor for die wear.

FEATURES AND SPECIFICATIONS

- Visual display overlays the measurement onto the specified design
- Point and gage analysis measures the thickness and width of each breakpoint
- Conicity analysis compares the right and left extrusion halves
- Regional analysis reports the area and center of gravity for each region
- Statistical analysis allows export of data for analysis in spreadsheet applications
- Experienced users report that fewer die trials are needed, conserving time and raw materials
- Dies can be designed to increasingly tighter tolerances for materials that are more difficult to extrude uniformly

Specifications

| Measurement Parameter | Car Tire Model | Truck Tire Model |
|-------------------------------------|---------------------|---------------------|
| Thickness Measurement Range | 30mm | 60mm |
| Width Measurement Range | 600mm | 900mm |
| Gage Repeatability on Flat Surfaces | <0.0125mm | <0.025mm |
| Gage Accuracy on Flat Surface | <0.060mm | <0.060mm |
| Area Calculation Repeatability | <.25% | <.25% |
| Area Calculation Accuracy | <.25% | <.25% |
| Sample Interval (Width Resolution) | 0.1mm | 0.1mm |
| Measurement Spot Size | 0.3mm | 0.3mm |
| Dimensions (W x D x H) | 1225 x 775 x 1400mm | 1524 x 775 x 1400mm |



Off-Line Profilometer (OFLP)



OFF-LINE PROFILOMETER SL

The Profilometer SL (PSL) combines the CrossCheck™ Line Laser Sensor technology with our proven Profilometer software platform to produce a low cost, reliable, and accurate tread and sidewall extrusion measurement system. PSL is an all-in-one package, with C-Frame, PC, and electronics combined into a mobile cart. PSL is non-contacting and has no moving parts, so reliability is uncommonly high. The measurement is instantaneous, so there is no waiting for results. With this new instant-scan capability and portability, geometry checks on tire components can be performed quickly at any location in the factory.

Specifications

Measurement Parameter

| | |
|-------------------------------------|--|
| Thickness Measurement Range | 60mm |
| Width Measurement Range | 300mm (4 sensors) 450mm (6 sensors) |
| Gage Repeatability of Flat Surfaces | <0.025mm |
| Gage Accuracy on Flat Surfaces | 0.075mm |
| Area Calculation Repeatability | <0.25% |
| Area Calculation Accuracy | <0.25% |
| Sample Interval (Width Resolution) | 0.1mm |
| Scan Speed | Instantaneous |
| Dimensions (W x L x H) | 77cm x 110cm x 104cm (excluding LCD monitor) |
| Laser Classification | IIIa CDRH, 3R IEC |

FEATURES AND SPECIFICATIONS

- No moving parts
- Instantaneous cycle time
- Portable
- Visual display overlays the measurement onto the specified design
- Point and gage analysis measures the thickness and width of each breakpoint
- Conicity analysis compares the right and left extrusion halves
- Regional analysis reports the area and center of gravity for each region
- Statistical analysis allows export of data for analysis in spreadsheet applications
- Experienced users report that fewer die trials are needed, conserving time and raw materials
- Dies can be designed to increasingly tighter tolerances for materials that are more difficult to extrude uniformly



Off-Line Profilometer PL (PSL)



PROFILE360™ FOR APEX EXTRUSION

Profile360 is an in-line, real-time measurement system for continuously monitoring key profile dimensions in complex profile extrusions. Profile360 employs CrossCheck™ Line Laser Sensors manufactured by Starrett-Bytewise. These multi-sensor systems acquire thousands of data points around the profile and match them to a CAD template, where key measurement parameters such as width, thickness, radius, and angle are extracted. Measurement parameters are compared to allowable control limits and displayed on the operator's terminal with a green/yellow/red (pass/caution/fail) status indicator. Profile360 runs at rates up to 14 profiles per second.

| Specifications | |
|--|--|
| Measurement Rate | Selectable up to 14 profiles/second |
| Communication Interface | Analog and Digital Outputs; Ethernet |
| Run Modes | Clock Frequency or Encoder |
| Data Output | Modbus TCP or OPC Server native; conversion to other platforms available |
| Operating Temperature | 32 to 113 °F (0 to 45 °C); cooling systems available |
| Profile360 conforms to the Machinery Safety, Electromagnetic Compatibility, and Low Voltage directives of the EC | |
| Laser safety class by the CDRH standard is Class 3A, and the IEC 60825-1 classification is Class 3R | |

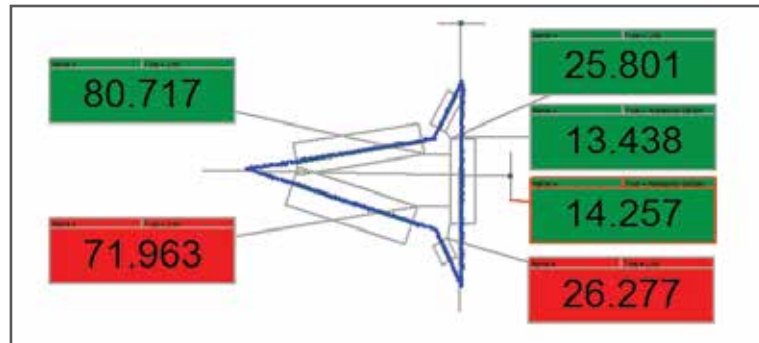

Profile360™ for Apex Extrusion



WHAT DOES IT DO?

Tire makers routinely measure production tires as a means of quality checking. Tire360 is a 3D tire scanning system that measures parameters like crown radius, section width, section height, circumference, and location and height of tread wear indicators.

Tire360 can be used with our CTWIST tread wear analysis software. Tread wear testing is accomplished by scanning a tire sequentially during a wear test program. The CTWIST software module provides for the following analyses: tread depth profile, irregular wear, tread life prediction, tread loss profile and heel/toe wear.

WHY DOES IT MATTER?

Tire360 can improve your workflow and reduce labor for routine tire measurement. Production tires can be scanned in less than 10 seconds and automatically analyzed for test parameters like crown radius, section width, section height, circumference, and location and height of tread wear indicators.

Tire360 can greatly reduce the time needed for tire scanning in your tread-wear testing too. A test that takes 10 minutes with a fixed-point scanner can be done in 10 seconds! For a user checking tread wear for 10 vehicles per day the savings in testing labor is over 6 hours. That means 6 hours of additional driver productivity too - per day.

Tire scans can be permanently archived so you can go back and analyze tires after they have been shipped out.

HOW DOES IT WORK?

Tire360 is an off-line station that scans tires that have been pre-mounted on rims and inflated. The tire/rim assembly is manually mounted onto the spindle tooling. The machine rotates the spindle and scans the tire automatically.

The system utilizes CrossCheckHD™ sensors in a multi-sensor c-frame array. CrossCheckHD is a family of high speed line laser sensors manufactured by Starrett-Bytewise in Columbus, Georgia, USA. These are referred to by many other names – laser stripe sensors, sheet-of-light laser sensors, and laser profile sensors. HD designates the high data-density version that utilizes a high speed CMOS detector, produced according to our specification.

Each sensor projects a line of laser light across the tire surface, which is reflected back to the sensor through a lens and onto a CMOS detector where each profile is digitized. The digitized line is triangulated and converted to XY coordinates. A patented method is employed to transform, or stitch, the data sets into a common coordinate system.

Tire360 covers a large range of tire sizes by mounting the measurement head on a two-stage slide with one radial axis and one lateral axis. Axes are manually positioned and lockable. The axes are encoded in order to capture the true radius and circumference.

Tire360 software combines the individual sensor data sets into a single bead-to-bead point-data file for each scan, and combines the data sets by associating the profiles to the encoder count. The data set is unfolded to visualize a 3D surface topography in a "false color map" with 16 colors spanning $\pm 2\text{mm}$. This color map is normalized using a filtering tool-set to remove low-frequency runout. A full-range scan consists of 16,000 columns and 7,500 rows of data. Each radial and lateral waveform can be displayed in the contour view window.



Tire360



GEO-360

- GEO-360 is a tire geometry measurement system for retrofit to tire uniformity machines and balancers.
- It has a rack and pinion drive system that can easily be customized for travel and height.
- Sensors are mounted on pivoting break-away hinges secured with ball detents.
- An air blow-off system reduces contamination on the sensor glass.

MEASUREMENT PARAMETERS

- RRO and LRO
 - Peak-to-Peak
 - Composite
 - Harmonics 1 to 32 with angles
- Bulge and Depression – magnitude and angle top and bottom
- Wobble
- Section Width
- Tread Local RRO
- Open Cap Splice
- Circumference for each rib



GEO-360

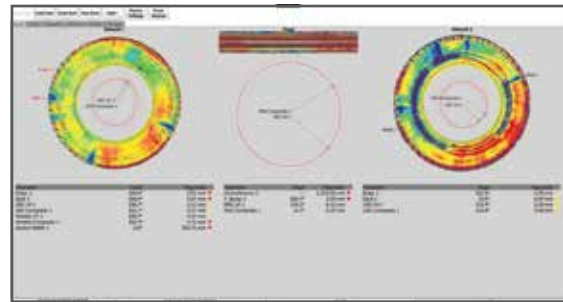

Results tab

NEW!
LASER MEASUREMENT

LINE LASER SENSORS AND SYSTEMS ARE DESIGNED AND BUILT BY STARRETT-BYTEWISE

How SENSORS WORK

A laser line is projected across the profile and the image is snapped by the detector, then the image data is converted to x+y coordinates.

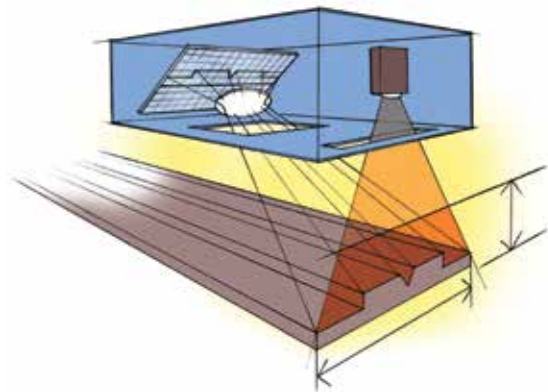

How SYSTEMS WORK

Multiple sensors are mounted on a positioning system to acquire scans of tread and sidewalls.

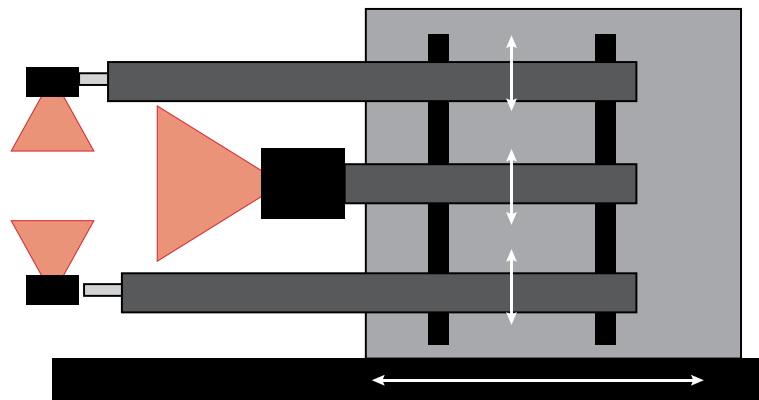

GREEN TIRE UNIFORMITY SYSTEM (GTU)

Tire Building is the most complex operation in the tire factory. Multiple components are centered, applied, spliced, turned-up, inflated, and stitched. Component stock variations combine with machine variations to produce green tires with variations in radial runout, tread snaking, lateral runout, and splice quality. Green tires with the largest variations invariably produce tires with the worst cured tire uniformity and balance performance.

The Green Tire Uniformity System utilizes the CrossCheckHD™ Line Laser Sensor to scan green tires at any stage of production. The GTU Software has a suite of viewing and analysis tools for assessing all aspects of the green tire uniformity. The system is available in two configurations - portable and fixed.

The portable tripod-mounted version can be moved from drum-to-drum, and from machine-to-machine. This provides a way to thoroughly study the carcass, belt/tread package, and final shaped green tire for radial and lateral runout, tread snaking, and splice quality. This can be used by the Set-Up Technician to verify the TBM set-up, and can be used by the Uniformity Engineer to troubleshoot tires with uniformity problems.

The fix-mounted version provides a means to perform 100% inspection at any drum for any parameter. This is useful for understanding the population characteristics of green tire runouts and to alarm when limits are exceeded.

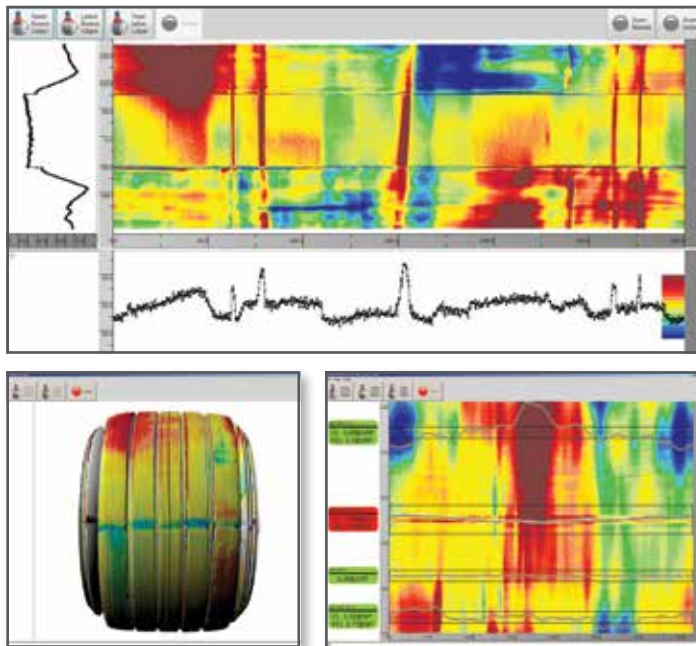

SYSTEM CHARACTERISTICS

- Start scan from keyboard.
- Start scan from relay contact.
- Scan with encoder count.
- Scan number of profiles.
- Scan from encoder start/stop.
- View runout color map.
- View 3D image.
- View circumferential waveform.
- View lateral waveform.
- View harmonics.
- Filter data.
- Rotate data.
- Crop data.
- Radial runout caliper.
- Lateral runout caliper.
- Tread splice caliper.
- Width caliper.
- Circumference caliper.
- Set pass/fail limits.
- Subtract layers.
- Export caliper waveform as .csv.
- Export point cloud as .csv.
- Portable system includes sensor, notebook PC, and carry case.
- Fix-Mounted System includes sensor, PC, and PLC interface module.

INTEGRATED SHAPING DRUM SYSTEM

Since RRO and LRO of the green tire have the strongest association with cured tire uniformity most agree that a check of the final shaped green tire provides the most comprehensive way to verify quality before sending the green tire to curing. This is done by integrating a single GTU sensor at the final shaping drum.

The parameters measured include LRO of the center groove, RRO, circumference and tread splice bulge. Runout values include harmonics and angles.

The software is optimized for a touchscreen operation. The Scan View tab shows a false-color map to display the runout topography. The bottom window displays the circumferential waveform and the left window displays the lateral waveform.

INTEGRATED CARCASS DRUM SYSTEM

Overlapping carcass splices have strong associations with cured-tire RRO/RV. The carcass system detects the leading edge and trailing of each component, associates each to an encoder tick, and calculates the splice overlap. The system also detects slipping of the plies on the inner liner and compensates the splice measurement. The reported measurement is right and left side splice overlap.



TREAD WEAR MEASUREMENT SYSTEM (CTWIST)

Tire designers are challenged to develop new tread patterns and compounds that deliver longer tread life and more uniform tread wear. Starrett-Bytewise partnered with Ford Motor Company and several leading OEM tire makers to develop CTWIST as a way to measure and characterize tread wear so the designers could better understand wear behavior. With the CTWIST process, new tires are scanned after break-in, then periodically scanned during the wear cycles. CTWIST predicts the tread life for each rib, and produces several tread wear reports to help the designer understand where improvements are needed.

CTWIST utilizes a non-contacting high-speed laser sensor to collect about 1,000,000 measuring points in less than 5 minutes.

FEATURES

- Tread Depth Profile Report shows the tread depth profile for each wear cycle
- Heel/Toe Wear Report shows the heel-toe wear profile across the tread
- Irregular Wear Report shows a 3D color map of the tread loss
- Tread Loss Report shows the tread loss profile across the tread
- Tread Life Mileage Projection shows the predicted tread life of each rib

System Specifications

| | |
|--|----------------------------------|
| Typical Measurement Time | 5 minutes |
| Measurement Technology | Scanned Laser Triangulation |
| Measurement Range | 32mm |
| Laser Standoff | 180mm |
| Measurement Spot Diameter | 0.1mm |
| Laser Classification | Class IIIb Gallium Arsenide |
| Laser Resolution | < 0.008mm |
| Data Signal | Digital with Invalid Data Signal |
| Data Points per Scan Line | 4096 |
| Senor Frequency | 16kHz |
| Encoder | = 16,000 PPR |
| Typical Data File Size | 1Mb |
| Compatible Tire Radius Range | 200 to 625mm |
| Compatible Tire Widths | Up to 400mm |
| Maximum Tire and Wheel Assembly Weight | 100kg |
| Maximum Tire Rotation Speed | 120RPM |
| Machine Dimensions (W x D x H) | 1000 x 1150 x 900mm |



Tread Wear Measurement System



BEAD-TO-BEAD PROFILE MEASUREMENT SYSTEM

Tire and mold designers are tasked with creating new tire designs that meet strict dimensional requirements when the tire is inflated. The inflated growth is predicted using powerful CAD modeling software. The inflated tire is traditionally measured with hand tools to check compliance to the design target. Checking with hand tools is time consuming, imprecise, and operator dependent.

The Starrett-Bytewise Bead-to-Bead Measurement System (B2B) is a non-contact scanning system that provides instantaneous acquisition for tire profiles from one bead to the other, across both sidewalls and the tread. Data is rendered in a visual display. Drag and drop caliper tools enable easy measurement. The CAD model can be imported into the Bead-to-Bead software so that the actual profile can be overlaid to the design. Data can be exported back to the CAD system for further analysis.

Bead-to-Bead can scan tires rotating at high speed to measure centrifugal growth and deformation.

FEATURES

- Acquires 4,000 or more data points per profile
- Acquires complete profiles in less than one second
- Profiles are rendered in a visual display and matched to a CAD template
- Profiles are analyzed with easy-to-use tools for section width, crown radius, and other parameters
- Data points are output in .dxf and .txt formats

Specifications

| | |
|---------------------------|--|
| Tire Size Capability | Various configurations to accommodate tire sizes ranging from passenger to truck and bus |
| Sensor Accuracy | 0.15mm (based on standard sensors) |
| Measurement Accuracy* | 0.15mm or 0.3mm |
| Triggering | Keyboard |
| Point Data Output Formats | DXF, TXT |
| Communication Interface | Digital and Analog I/O, Ethernet (Modbus TCP) |
| Laser Classification | Illa |

* Measurement accuracy will depend on whether the data required to complete the desired measurement comes from one or two sensors.



Bead-to-Bead Profile Measurement System





**PRECISION GROUND FLAT STOCK
AND DRILL ROD**

PRECISION FLAT STOCK AND DRILL ROD



Cut costs and save time - make your own parts like these from Flat Stock

PRECISION GROUND FLAT STOCK AND DRILL ROD STANDARD AND OVERSIZE

Starrett Precision Ground Flat Stock and Drill Rod can save time in your shop ... no more time hunting lost stock ... no more slow, costly grinding to size. Just lay it out and saw it out and save valuable machinery, downtime and man hours.

- Machine parts
- Shims
- Flat gages
- Fixtures
- Stamps
- Punches
- Parallels
- Templates
- Cutters
- Dies
- Jigs
- Buttons
- Test gages
- Test tools

Six types of material in a complete range of sizes is available to meet your specific needs:

495 and 496 are (AISI O1) oil hardening tool steels. These steels are dimensionally stable and can be used for all intricate work, including work with thin sections, with a minimum danger of cracking.

497 and 499 are (AISI A2) 5% chromium air-hardening steel. These steels have high wear and abrasion resistance.

498 Low carbon steel is used where deep hardening is not necessary, although it can be carburized or case hardened.

344 is (AISI A6) a medium alloyed air hardening tool steel that provides an excellent balance of machinability, toughness and wear resistance.

W1 Carbon (Available only in Drill Rod) is (AISI/SAE W1) a versatile and less expensive carbon steel with excellent machinability, good wear resistance and toughness.

401 and 402 are (AISI D2) high chromium steel. These steels are for the highest wear resistance applications.



PACKAGING

Starrett Precision Ground Flat Stock is individually wrapped in brown paper and clearly marked with size dimensions, analysis and correct hardening and tempering information. Drill rods are bundled together and tagged with a description that includes the size and EDP number. Color coding by grade on the ends of each piece allows for easy identification.

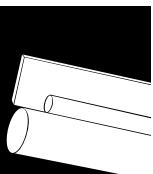



Cut costs and save time - make your own parts like these from Drill Rod

| Flat Stock Tolerances | |
|---|---|
| Standard: | Thickness $\pm .001$ " Widths Up through 8", $+.000/.005$ " 9" and Over, $+.000/.015$ " Squares, $\pm .001$ " |
| Override: | Thickness, $+.010/.015$ " Width, $+.010/.015$ " Squares, $+.010/.015$ " |
| Length: Saw Cut Oversize to Allow for Finish Cutting | 18", $+1/4$ " 24", $+1/2$ " 36", $+5/8$ " |
| Squareness Edge All: | .003" Per Inch |
| Finish: | 35 Microinch or Finer |

| Drill Rod Tolerances | | |
|----------------------|--------------------|------------------|
| Size Range | Diameter Tolerance | Length Tolerance |
| .124" round and less | $\pm .0003$ " | |
| .125" to .499" | $\pm .0005$ " | $+1/8" - 0$ |
| .500" to 2" | $\pm .0010$ " | |

COMPARATIVE FEATURE PROPERTIES

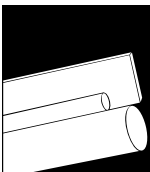
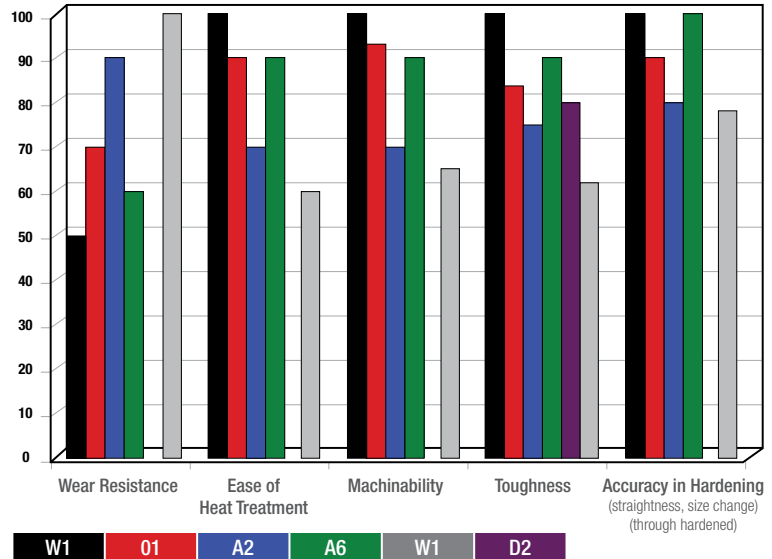

PRECISION GROUND FLAT STOCK

496 OIL HARDENING PRECISION GROUND FLAT STOCK

STANDARD

495 OIL HARDENING PRECISION GROUND FLAT STOCK

OVERSIZE

- Stock is dimensionally stable – use it for the most intricate work
- Deep hardening characteristics and fine grain structure
- Machines freely – fully spheroidized, annealed
- Full length identification – eliminates confusion with other steels
- Starrett uses its own ground flat stock and die stock for many of its fine precision tool parts

NOMINAL ANALYSIS (AISI 01)

| | |
|-----------------|------|
| Carbon | .90 |
| Chromium | .50 |
| Manganese | 1.20 |
| Tungsten | .50 |
| Vanadium | .20 |

| Size | Temperature | Quench | Rockwell C |
|-----------|---------------|--------|------------|
| All Sizes | 1450°-1500° F | Oil | 63-65 |



SPECIFICATIONS

Furnished in 18" and 36" lengths, ground straight and parallel.

HARDENING

It is recommended that stock be heated uniformly to 1450°-1500° F and quenched in oil. Temperature of the quenching oil should be 120°-140° F for best results. Do not quench in water because this is an oil hardening steel.

TEMPERING

For maximum toughness, a tempering time of one hour at temperature is recommended. Use chart for selecting desired Rockwell C hardness and corresponding tempering temperature. The following may also be used as a guide depending on type of work.

CUTTING TOOLS

- 300°-350° F (Light Straw)

SOLID PUNCHES AND DIES

- 400°-450° F (Straw)

SPRING TEMPER

- 750°-800° F (Blue)

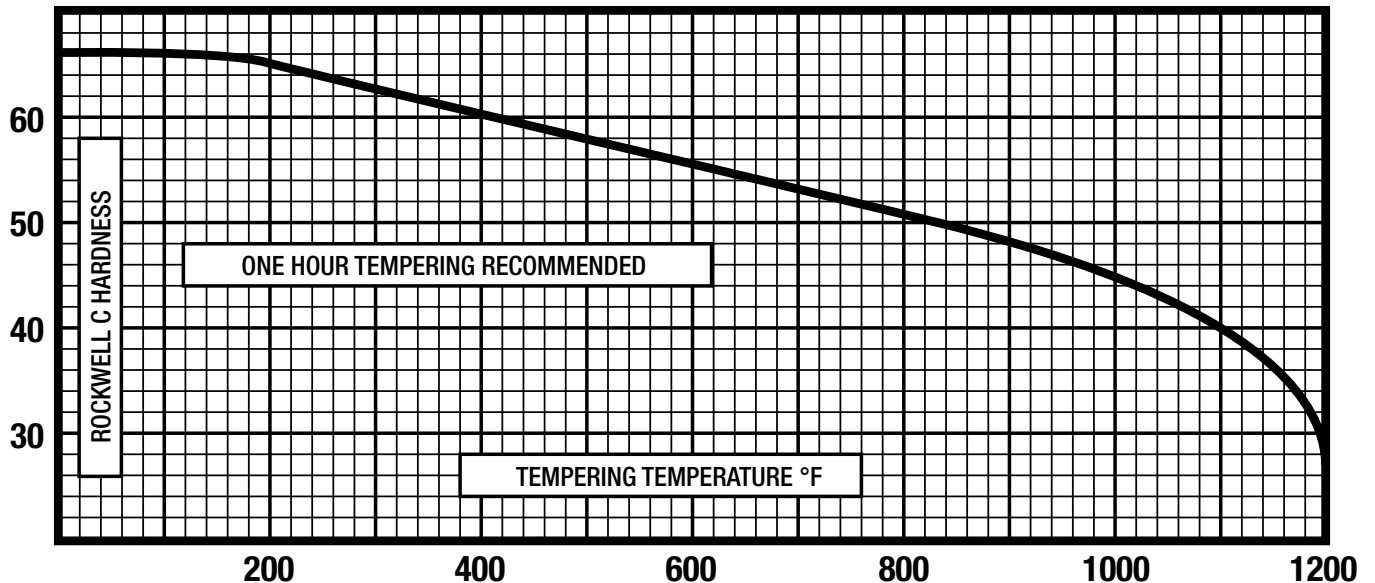

NOTE: Lengths, widths and thicknesses other than listed can also be quoted by request

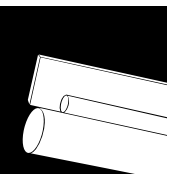

PRECISION GROUND FLAT STOCK

496 OIL HARDENING PRECISION GROUND FLAT STOCK

STANDARD TOLERANCE

| 496 Oil Hardening Precision Ground Flat Stock | | | |
|---|--------|------------|------------|
| Thickness | Width | 18" Length | 36" Length |
| 1/64" | 1/2" | 53924 | 59139 |
| | 3/4" | 53925 | |
| | 1" | 53926 | |
| | 1-1/4" | 53927 | |
| | 1-1/2" | 53928 | |
| | 2" | 53929 | 59140 |
| | 2-1/2" | 53930 | |
| | 3" | 53931 | |
| 1/32" | 4" | 53932 | 59141 |
| | 1/2" | 53933 | 58895 |
| | 3/4" | 53934 | 59143 |
| | 1" | 53935 | 59144 |
| | 1-1/4" | 53936 | |
| | 1-1/2" | 53937 | 59145 |
| | 2" | 53938 | 58901 |
| | 2-1/2" | 53939 | |
| 3/64" | 3" | 53940 | 59147 |
| | 4" | 53941 | 59148 |
| | 6" | 53942 | |
| | 1/2" | 53943 | 59149 |
| | 3/4" | 53944 | 59150 |
| | 1" | 53945 | 58902 |
| | 1-1/4" | 53946 | 59171 |
| | 1-1/2" | 53947 | 57685 |
| 1/16" | 2" | 53948 | 59152 |
| | 2-1/2" | 53949 | |
| | 3" | 53950 | |
| | 3-1/2" | 53951 | |
| | 4" | 53952 | 59153 |
| | 6" | 53953 | |
| | 1/4" | 57226 | 58891 |
| | 3/8" | 57227 | |
| 1/8" | 1/2" | 53954 | 54257 |
| | 3/4" | 53955 | 54258 |
| | 1" | 53956 | 54259 |
| | 1-1/4" | 53957 | 54260 |
| | 1-1/2" | 53958 | 54261 |
| | 1-3/4" | 53959 | 54262 |
| | 2" | 53960 | 54263 |
| | 2-1/2" | 53961 | 54264 |
| | 3" | 53962 | 54265 |
| | 3-1/2" | 53963 | 54266 |
| | 4" | 53964 | 54267 |
| | 5" | 53965 | 54268 |
| | 6" | 53966 | 54269 |
| | 8" | 53967 | 57236 |
| 10" | 53968 | 57237 | |
| 5/64" | 1/2" | 53969 | 54270 |
| | 3/4" | 53970 | 58905 |
| | 1" | 53971 | 58890 |
| | 1-1/2" | 53972 | |
| | 2" | 53973 | |
| | 2-1/2" | 53974 | |
| | 3" | 53975 | |
| | 4" | 53976 | |
| 6" | 53977 | | |

| 496 Oil Hardening Precision Ground Flat Stock | | | |
|---|--------|------------|------------|
| Thickness | Width | 18" Length | 36" Length |
| 3/32" | 1/4" | | 58899 |
| | 3/8" | 58903 | |
| | 1/2" | 53978 | 54279 |
| | 3/4" | 53979 | 54280 |
| | 1" | 53980 | 54281 |
| | 1-1/4" | 53981 | 54282 |
| | 1-1/2" | 53982 | 54283 |
| | 2" | 53983 | 54284 |
| | 2-1/2" | 53984 | 54285 |
| | 3" | 53985 | 54286 |
| | 4" | 53986 | 54287 |
| | 5" | 53987 | 54288 |
| 7/64" | 6" | 53988 | 54289 |
| | 8" | 53989 | 57682 |
| | 1/2" | 53990 | |
| | 3/4" | 53991 | |
| | 1" | 53992 | |
| | 1-1/4" | 53993 | |
| | 1-1/2" | 53994 | |
| | 2" | 53995 | |
| 1/8" | 3" | 53996 | |
| | 4" | 53997 | |
| | 1/8" | 53998 | 59154 |
| | 1/4" | 57228 | 58894 |
| | 5/16" | 59127 | 58897 |
| | 3/8" | 57229 | 58892 |
| | 1/2" | 53999 | 54298 |
| | 5/8" | 54000 | 54299 |
| | 3/4" | 54001 | 54300 |
| | 1" | 54002 | 54301 |
| | 1-1/4" | 54003 | 54302 |
| | 1-1/2" | 54004 | 54303 |
| | 1-3/4" | 54005 | 54304 |
| | 2" | 54006 | 54305 |
| 9/64" | 2-1/2" | 54007 | 54306 |
| | 3" | 54008 | 54307 |
| | 3-1/2" | 54009 | 54308 |
| | 4" | 54010 | 54309 |
| | 4-1/2" | 54011 | 54310 |
| | 5" | 54012 | 54311 |
| | 6" | 54013 | 54312 |
| | 7" | 54014 | 54313 |
| | 8" | 54015 | 54314 |
| | 10" | 54016 | 54315 |
| | 12" | 54017 | 54316 |
| | 14" | 54018 | 57238 |
| | 9/64" | 54019 | |
| | 1/2" | 54020 | |
| 3/4" | 54021 | | |
| 1" | 54022 | | |
| 1-1/2" | 54023 | | |
| 2" | 54024 | | |
| 3" | 54025 | | |
| 4" | 54026 | | |
| 5/32" | 5/32" | 54027 | |
| | 1/2" | 54028 | 54324 |
| | 3/4" | 54029 | 54325 |
| | 1" | 54030 | 54326 |
| | 1-1/4" | 54031 | 54327 |
| | 1-1/2" | 54032 | 54328 |

| 496 Oil Hardening Precision Ground Flat Stock | | | |
|---|--------|------------|------------|
| Thickness | Width | 18" Length | 36" Length |
| 5/32" | 1-3/4" | 54033 | 54329 |
| | 2" | 54034 | 54330 |
| | 2-1/2" | 54035 | 54331 |
| | 3" | 54036 | 54332 |
| | 3-1/2" | 54037 | 54333 |
| | 4" | 54038 | 54334 |
| | 5" | 54039 | 54335 |
| | 6" | 54040 | 54336 |
| 3/16" | 8" | 54041 | 54337 |
| | 3/16" | 54042 | 59157 |
| | 1/4" | 57230 | |
| | 3/8" | 57231 | |
| | 1/2" | 54043 | 54338 |
| | 3/4" | 54044 | 54339 |
| | 1" | 54045 | 54340 |
| | 1-1/4" | 54046 | 54341 |
| | 1-1/2" | 54047 | 54342 |
| | 1-3/4" | 54048 | 54343 |
| | 2" | 54049 | 54344 |
| | 2-1/2" | 54050 | 54345 |
| 7/32" | 3" | 54051 | 54346 |
| | 3-1/2" | 54052 | 54347 |
| | 4" | 54053 | 54348 |
| | 5" | 54054 | 54349 |
| | 6" | 54055 | 54350 |
| | 8" | 54056 | 54351 |
| | 10" | 54057 | 54352 |
| | 7/32" | 54058 | |
| | 1/2" | 54059 | 54353 |
| | 3/4" | 54060 | 54354 |
| 1/4" | 1" | 54061 | 54355 |
| | 1-1/4" | 54062 | 54356 |
| | 1-1/2" | 54063 | 54357 |
| | 2" | 54064 | 54358 |
| | 3" | 54065 | 54359 |
| | 4" | 54066 | 54360 |
| | 6" | 54067 | |
| | 1/4" | 54068 | 56517 |
| | 3/8" | 54069 | 58900 |
| | 1/2" | 54070 | 54362 |
| | 5/8" | 58904 | 58893 |
| | 3/4" | 54071 | 54363 |
| | 1" | 54072 | 54364 |
| | 1-1/4" | 54073 | 54365 |
| 1-1/2" | 54074 | 54366 | |
| 1-3/4" | 54075 | 54367 | |
| 2" | 54076 | 54368 | |
| 2-1/2" | 54077 | 54369 | |
| 3" | 54078 | 54370 | |
| 3-1/2" | 54079 | 54371 | |
| 4" | 54080 | 54372 | |
| 4-1/2" | 54081 | 54373 | |
| 5" | 54082 | 54374 | |
| 5-1/2" | 54083 | 54375 | |
| 6" | 54084 | 54376 | |
| 7" | 54085 | 54377 | |
| 8" | 54086 | 54378 | |
| 10" | 54087 | 54379 | |
| 12" | 54088 | 54380 | |
| 14" | 54089 | 57239 | |

Sizes other than listed priced on application

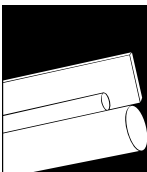

PRECISION GROUND FLAT STOCK

496 OIL HARDENING PRECISION GROUND FLAT STOCK

STANDARD TOLERANCE (CONTINUED)

| 496 Oil Hardening Precision Ground Flat Stock | | | |
|---|--------|------------|------------|
| Thickness | Width | 18" Length | 36" Length |
| 9/32" | 9/32" | 54090 | |
| | 1/2" | 54091 | |
| | 3/4" | 54092 | |
| | 1" | 54093 | |
| | 1-1/4" | 54094 | |
| | 1-1/2" | 54095 | |
| | 2" | 54096 | |
| | 2-1/2" | 54097 | |
| | 3" | 54098 | |
| | 4" | 54099 | |
| 6" | 54100 | 54390 | |
| 5/16" | 5/16" | 54101 | 54391 |
| | 3/8" | 57232 | |
| | 1/2" | 54102 | 54392 |
| | 5/8" | | 58896 |
| | 3/4" | 54103 | 54393 |
| | 1" | 54104 | 54394 |
| | 1-1/4" | 54105 | 54395 |
| | 1-1/2" | 54106 | 54396 |
| | 1-3/4" | 57233 | 57240 |
| | 2" | 54107 | 54397 |
| | 2-1/2" | 54108 | 54398 |
| | 3" | 54109 | 54399 |
| | 3-1/2" | 54110 | 54400 |
| | 4" | 54111 | 54401 |
| | 4-1/2" | 54112 | 54402 |
| | 5" | 54113 | 54403 |
| 6" | 54114 | 54404 | |
| 8" | 54115 | 54405 | |
| 3/8" | 3/8" | 54116 | 54406 |
| | 1/2" | 54117 | 54407 |
| | 5/8" | | 58898 |
| | 3/4" | 54118 | 54408 |
| | 1" | 54119 | 54409 |
| | 1-1/4" | 54120 | 54410 |
| | 1-1/2" | 54121 | 54411 |
| | 1-3/4" | 54122 | 54412 |
| | 2" | 54123 | 54413 |
| | 2-1/2" | 54124 | 54414 |
| | 3" | 54125 | 54415 |
| | 3-1/2" | 54126 | 54416 |
| | 4" | 54127 | 54417 |
| | 4-1/2" | 54128 | 54418 |
| | 5" | 54129 | 54419 |
| | 5-1/2" | 54130 | 54420 |
| 6" | 54131 | 54421 | |
| 7" | 54132 | 54422 | |
| 8" | 54133 | 54423 | |
| 10" | 54134 | 54424 | |
| 12" | 54135 | 54425 | |
| 7/16" | 7/16" | 54136 | 54426 |
| | 1/2" | 54137 | 54427 |
| | 3/4" | 54138 | 54428 |
| | 1" | 54139 | 54429 |
| | 1-1/4" | 54140 | 54430 |
| | 1-1/2" | 54141 | 54431 |
| | 2" | 54142 | 54432 |
| | 2-1/2" | 54143 | 54433 |
| | 3" | 54144 | 54434 |
| | 4" | 54145 | 54435 |
| 6" | 54146 | 54436 | |

| 496 Oil Hardening Precision Ground Flat Stock | | | |
|---|--------|------------|------------|
| Thickness | Width | 18" Length | 36" Length |
| 1/2" | 1/2" | 54147 | 54437 |
| | 5/8" | 54148 | 54438 |
| | 3/4" | 54149 | 54439 |
| | 1" | 54150 | 54440 |
| | 1-1/4" | 54151 | 54441 |
| | 1-1/2" | 54152 | 54442 |
| | 1-3/4" | 57234 | 57241 |
| | 2" | 54153 | 54443 |
| | 2-1/2" | 54154 | 54444 |
| | 3" | 54155 | 54445 |
| | 3-1/2" | 54156 | 54446 |
| | 4" | 54157 | 54447 |
| | 4-1/2" | 54158 | 54448 |
| | 5" | 54159 | 54449 |
| 9/16" | 6" | 54160 | 54450 |
| | 7" | 54161 | 54451 |
| | 8" | 54162 | 54452 |
| | 10" | 54163 | 54453 |
| | 12" | 54164 | 59159 |
| | 14" | 54165 | |
| | 9/16" | 54166 | 54455 |
| | 3/4" | 54167 | 54456 |
| | 1" | 54168 | 54457 |
| | 1-1/4" | 54169 | 54458 |
| 1-1/2" | 54170 | 54459 | |
| 2" | 54171 | 54460 | |
| 5/8" | 5/8" | 54172 | 54461 |
| | 3/4" | 54173 | 54462 |
| | 1" | 54174 | 54463 |
| | 1-1/4" | 54175 | 54464 |
| | 1-1/2" | 54176 | 54465 |
| | 2" | 54177 | 54466 |
| | 2-1/2" | 54178 | 54467 |
| | 3" | 54179 | 54468 |
| | 3-1/2" | 54180 | 54469 |
| | 4" | 54181 | 54470 |
| | 5" | 54182 | 54471 |
| | 6" | 54183 | 54472 |
| 3/4" | 8" | 54185 | 54474 |
| | 10" | 54186 | 54475 |
| | 12" | 57235 | 57242 |
| | 3/4" | 54187 | 54476 |
| | 1" | 54188 | 54477 |
| | 1-1/4" | 54189 | 54478 |
| | 1-1/2" | 54190 | 54479 |
| | 2" | 54191 | 54480 |
| | 2-1/2" | 54192 | 54481 |
| | 3" | 54193 | 54482 |
| | 3-1/2" | 54194 | 54483 |
| | 4" | 54195 | 54484 |
| | 4-1/2" | 54196 | 54485 |
| | 5" | 54197 | 54486 |
| 6" | 54198 | 54487 | |
| 8" | 54199 | 54488 | |
| 10" | 54200 | 54489 | |
| 12" | 54201 | 54490 | |

| 496 Oil Hardening Precision Ground Flat Stock | | | |
|---|--------|------------|------------|
| Thickness | Width | 18" Length | 36" Length |
| 7/8" | 7/8" | 54202 | 54491 |
| | 1" | 54203 | 54492 |
| | 1-1/4" | 54204 | 54493 |
| | 1-1/2" | 54205 | 54494 |
| | 2" | 54206 | 54495 |
| | 2-1/2" | 54207 | 54496 |
| | 3" | 54208 | 54497 |
| | 4" | 54209 | 54498 |
| 1" | 6" | 54210 | 54499 |
| | 1" | 54211 | 54500 |
| | 1-1/4" | 54212 | 54501 |
| | 1-1/2" | 54213 | 54502 |
| | 2" | 54214 | 54503 |
| | 2-1/2" | 54215 | 54504 |
| | 3" | 54216 | 54505 |
| | 3-1/2" | 54217 | 54506 |
| | 4" | 54218 | 54507 |
| | 4-1/2" | 54219 | 54508 |
| 1-1/8" | 5" | 54220 | 54509 |
| | 6" | 54221 | 54510 |
| | 8" | 54222 | 54511 |
| | 10" | 54223 | 54512 |
| | 12" | 54224 | 54513 |
| | 1-1/2" | 54225 | 54514 |
| | 2" | 54226 | 54515 |
| | 3" | 54227 | 54516 |
| 1-1/4" | 4" | 54228 | 54517 |
| | 6" | 54229 | 54518 |
| | 1-1/4" | 54230 | 54519 |
| | 1-1/2" | 54231 | 54520 |
| | 2" | 54232 | 54521 |
| | 2-1/2" | 54233 | 54522 |
| | 3" | 54234 | 54523 |
| | 4" | 54235 | 54524 |
| 1-1/2" | 5" | 54236 | 54525 |
| | 6" | 54237 | 54526 |
| | 8" | 54238 | 54527 |
| | 10" | 54239 | 54528 |
| | 1-1/2" | 54240 | 54529 |
| | 2" | 54241 | 54530 |
| | 2-1/2" | 54242 | 54531 |
| | 3" | 54243 | 54532 |
| 2" | 3-1/2" | 54244 | 54533 |
| | 4" | 54245 | 54534 |
| | 5" | 54246 | 54535 |
| | 6" | 54247 | 54536 |
| | 8" | 54248 | 54537 |
| | 10" | 54249 | 54538 |
| | 12" | 59189 | |
| | 2" | 54250 | 54539 |
| 2" | 3" | 54251 | 54540 |
| | 4" | 54252 | 54541 |
| | 6" | 54253 | 54542 |

Sizes other than listed priced on application

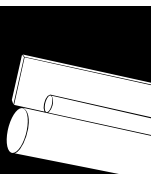

PRECISION GROUND FLAT STOCK

495 OIL HARDENING PRECISION GROUND FLAT STOCK

OVERSIZE TOLERANCE

| 495 Oil Hardening Ground Flat Stock | | | |
|-------------------------------------|--------|------------|------------|
| Thickness | Width | 18" Length | 36" Length |
| 3/16" | 3/16" | 56957 | 57677 |
| | 1/2" | 56958 | 56813 |
| | 3/4" | 56959 | 56814 |
| | 1" | 56960 | 56815 |
| | 1-1/4" | 56961 | 56816 |
| | 1-1/2" | 56962 | 56817 |
| | 2" | 56963 | 56818 |
| | 2-1/2" | 56964 | 56819 |
| | 3" | 56965 | 56820 |
| | 4" | 56966 | 56821 |
| 1/4" | 5" | 56967 | |
| | 6" | 56968 | 56822 |
| | 8" | 56969 | |
| | 10" | 56970 | |
| | 1/4" | 56971 | 57678 |
| | 1/2" | 56972 | 56823 |
| | 3/4" | 56973 | 56824 |
| | 1" | 56974 | 56825 |
| | 1-1/4" | 56975 | 56826 |
| | 1-1/2" | 56976 | 56827 |
| 5/16" | 1-3/4" | 56977 | |
| | 2" | 56978 | 56828 |
| | 2-1/2" | 56979 | 56829 |
| | 3" | 56980 | 56830 |
| | 3-1/2" | 56981 | 56831 |
| | 4" | 56982 | 56832 |
| | 4-1/2" | 56983 | |
| | 5" | 56984 | 56833 |
| | 6" | 56985 | 56834 |
| | 8" | 56986 | |
| 3/8" | 5/16" | 56987 | |
| | 1/2" | 56988 | 56835 |
| | 3/4" | 56989 | 56836 |
| | 1" | 56990 | 56837 |
| | 1-1/4" | 56991 | 56838 |
| | 1-1/2" | 56992 | 56839 |
| | 2" | 56993 | 56840 |
| | 2-1/2" | 56994 | 56841 |
| | 3" | 56995 | 56842 |
| | 4" | 56996 | 56843 |
| 1" | 5" | 56997 | 56844 |
| | 6" | | 56845 |
| | 3/8" | 56998 | 57679 |
| | 1/2" | 56999 | 56846 |
| | 3/4" | 57000 | 56847 |
| | 1" | 57001 | 56848 |
| | 1-1/4" | 57002 | 56849 |
| | 1-1/2" | 57003 | 56850 |
| | 2" | 57004 | 56851 |
| | 2-1/2" | 57005 | 56852 |
| 3/4" | 3" | 57006 | 56853 |
| | 3-1/2" | 57007 | |
| | 4" | 57008 | 56854 |
| | 4-1/2" | 57009 | |
| | 5" | 57010 | 56855 |
| | 6" | 57011 | 56856 |
| | 8" | 57012 | 56857 |
| | 12" | 57013 | |

| 495 Oil Hardening Ground Flat Stock | | | |
|-------------------------------------|--------|------------|------------|
| Thickness | Width | 18" Length | 36" Length |
| 1/2" | 1/2" | 57014 | 56858 |
| | 3/4" | 57015 | 56859 |
| | 1" | 57016 | 56860 |
| | 1-1/4" | 57017 | 56861 |
| | 1-1/2" | 57018 | 56862 |
| | 2" | 57019 | 56863 |
| | 2-1/2" | 57020 | 56864 |
| | 3" | 57021 | 56865 |
| | 3-1/2" | 57022 | |
| | 4" | 57023 | 56866 |
| | 4-1/2" | 57024 | |
| | 5" | 57025 | 56867 |
| 5/8" | 6" | 57026 | 56868 |
| | 8" | 57027 | 56869 |
| | 10" | 57028 | 56870 |
| | 12" | 57029 | |
| | 5/8" | 57030 | 56871 |
| | 3/4" | 57031 | 57680 |
| | 1" | 57032 | 56872 |
| | 1-1/4" | 57033 | 56873 |
| | 1-1/2" | 57034 | 56874 |
| | 2" | 57035 | 56875 |
| | 2-1/2" | 57036 | 56876 |
| | 3" | 57037 | 56877 |
| 3/4" | 3-1/2" | 57038 | |
| | 4" | 57039 | 56878 |
| | 5" | 57040 | 56879 |
| | 6" | 57041 | 56880 |
| | 3/4" | 57042 | 56881 |
| | 1" | 57043 | 56882 |
| | 1-1/4" | 57044 | |
| | 1-1/2" | 57045 | 56883 |
| | 2" | 57046 | 56884 |
| | 2-1/2" | 57047 | 56885 |
| | 3" | 57048 | 56886 |
| | 3-1/2" | 57049 | |
| 1" | 4" | 57050 | 56887 |
| | 5" | 57051 | |
| | 6" | 57052 | 56888 |
| | 8" | 57053 | |
| | 1" | 57054 | 56889 |
| | 1-1/4" | 57055 | 57681 |
| | 1-1/2" | 57056 | 56890 |
| | 2" | 57057 | 56891 |
| | 2-1/2" | 57058 | 56892 |
| | 3" | 57059 | 56893 |
| | 3-1/2" | 57060 | |
| | 4" | 57061 | 56894 |
| 5" | 57062 | | |
| 6" | 57063 | 56895 | |

Sizes other than listed priced on application

FLAT STOCK AND DRILL ROD

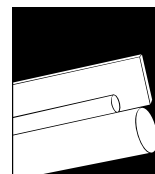

PRECISION GROUND FLAT STOCK

497 AIR HARDENING PRECISION GROUND FLAT STOCK

STANDARD

499 AIR HARDENING PRECISION GROUND FLAT STOCK

OVERSIZE

DIMENSIONALLY STABLE

- The 5% chromium content makes this steel especially desirable for punches and dies to be used in long production runs since it gives the tools far longer life. Up to 50% more pieces per sharpening can be produced than with oil hardening steel.
- High wear resistance is also ideal for punches and dies to stamp silicon, stainless steels, monel metal and other types of abrasive material
- Maintains close dimensional accuracy throughout the heat treating process. The wide 75° hardening range make this virtually foolproof.
- Full-length identification eliminates confusion with other steels
- Starrett uses its own ground flat stock for many of its precision tool parts

NOMINAL ANALYSIS (AISI A2)

| | |
|------------------|------|
| Carbon | 1.00 |
| Chromium | 5.25 |
| Manganese | .60 |
| Molybdenum | 1.00 |
| Vanadium | .25 |

| Size | Temperature | Cool | Rockwell C |
|-----------|---------------|-----------|------------|
| All Sizes | 1700°-1775° F | Still Air | 63.5-65 |

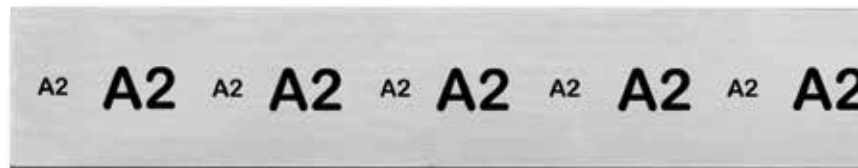

SPECIFICATIONS

Furnished in 18" and 36" lengths, ground straight and parallel.

HARDENING

497 and 499 Air Hardening Ground Flat Stock have a wide hardening range of 1700°F to 1775°F, with 1750°F recommended for most work. For heavier sections use the high side of the range. Heat uniformly throughout but do not soak longer than necessary. Cool in still air. No pre-heat is required if pack or atmosphere controlled furnace methods are used, but with the open furnace method a pre-heat of 1450°F is recommended.

TEMPERING

A tempering time of two hours at temperature is recommended. Use chart for selecting the desired Rockwell C hardness and corresponding tempering temperature. For maximum toughness, double temper for two hours at each temperature recommended. The following may also be used as a guide, depending on the type of work.

LIGHT BLANKING PUNCHES AND DIES

- 400°-425° F

HEAVY BLANKING PUNCHES AND DIES

- 700° F

ANNEALING

1525°-1575° F. Furnace cool at no more than 50° per hour to 800° for maximum softness.

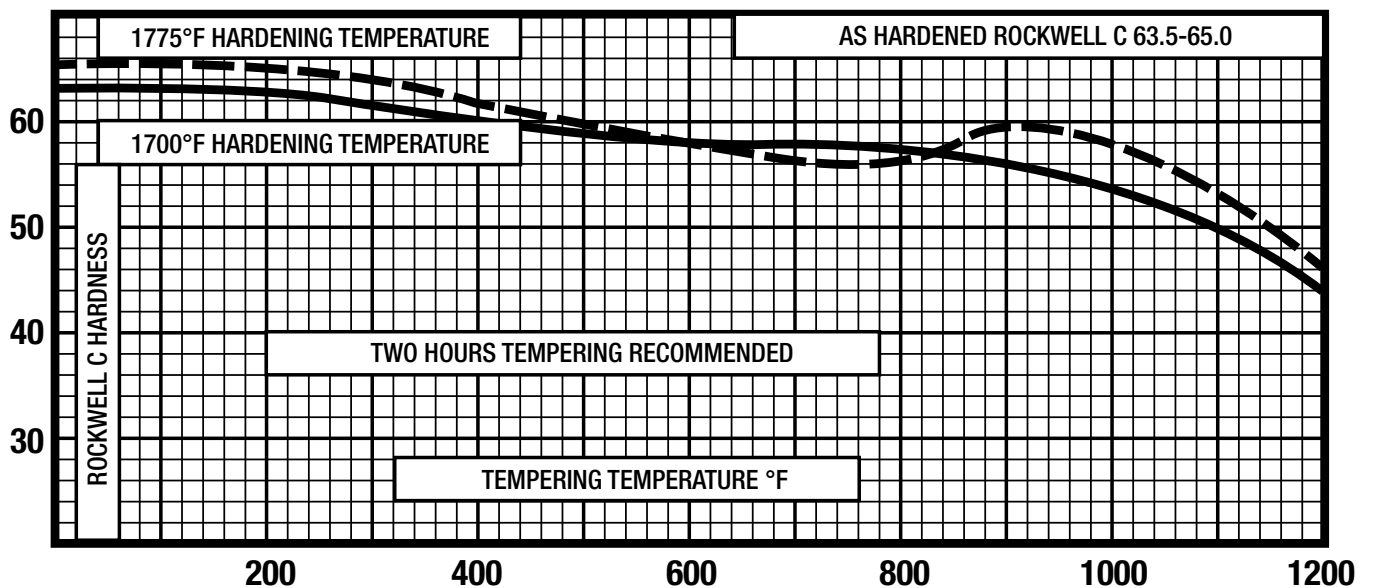

499, 1-1/4" and over is Blanchard ground with saw cut edges

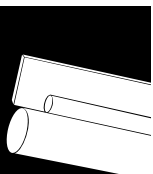

PRECISION GROUND FLAT STOCK

497 AIR HARDENING PRECISION GROUND FLAT STOCK

STANDARD TOLERANCE

| 497 Air Hardening Precision Ground Flat Stock | | | |
|---|--------|--------|--------|
| Thickness | Width | 18" | 36" |
| | | Length | Length |
| 1/16" | 1/2" | 57489 | 57301 |
| | 3/4" | 57490 | 57302 |
| | 1" | 57491 | 57303 |
| | 1-1/4" | 57492 | 57304 |
| | 1-1/2" | 57493 | 57305 |
| | 2" | 57494 | 57306 |
| | 2-1/2" | 57495 | 57307 |
| | 3" | 57496 | 57308 |
| | 4" | 57497 | 57309 |
| 3/32" | 1/2" | 57498 | 57310 |
| | 3/4" | 57499 | 57311 |
| | 1" | 57500 | 57312 |
| | 1-1/4" | 57501 | 57313 |
| | 1-1/2" | 57502 | 57314 |
| | 2" | 57503 | 57315 |
| | 2-1/2" | 57504 | 57316 |
| | 3" | 57505 | 57317 |
| | 4" | 57506 | 57318 |
| 1/8" | 1/2" | 57243 | 57245 |
| | 5/8" | 57507 | 57319 |
| | 3/4" | 57244 | 57246 |
| | 1" | 54589 | 54546 |
| | 1-1/4" | 54590 | 54547 |
| | 1-1/2" | 54591 | 54548 |
| | 1-3/4" | 57508 | 57320 |
| | 2" | 54592 | 54549 |
| | 2-1/2" | 54593 | 54550 |
| | 3" | 54594 | 54551 |
| | 3-1/2" | 54595 | 54552 |
| | 4" | 54596 | 54553 |
| | 5" | 54598 | 54555 |
| 6" | 54599 | 54556 | |
| 7" | 57509 | 57321 | |
| 8" | 57510 | 57322 | |
| 10" | 57511 | 57323 | |
| 12" | 57512 | 57324 | |
| 5/32" | 1/2" | 57513 | 57325 |
| | 3/4" | 57514 | 57326 |
| | 1" | 54600 | 54557 |
| | 1-1/4" | 54601 | 54558 |
| | 1-1/2" | 54602 | 54559 |
| | 1-3/4" | 57515 | 57327 |
| | 2" | 54603 | 54560 |
| | 2-1/2" | 54604 | 54561 |
| | 3" | 54605 | 54562 |
| 3-1/2" | 54606 | 54563 | |
| 4" | 54607 | 54564 | |
| 5" | 54608 | 54565 | |
| 6" | 54609 | 54566 | |
| 8" | 57516 | 57328 | |

| 497 Air Hardening Precision Ground Flat Stock | | | |
|---|--------|--------|--------|
| Thickness | Width | 18" | 36" |
| | | Length | Length |
| 3/16" | 3/16" | 57517 | 57329 |
| | 1/2" | 57518 | 57330 |
| | 3/4" | 57519 | 57331 |
| | 1" | 54610 | 54567 |
| | 1-1/4" | 54611 | 54568 |
| | 1-1/2" | 54612 | 54569 |
| | 1-3/4" | 57520 | 57332 |
| | 2" | 54613 | 54570 |
| | 2-1/2" | 54614 | 54571 |
| | 3" | 54615 | 54572 |
| | 3-1/2" | 54616 | 54573 |
| | 4" | 54617 | 54574 |
| 1/4" | 5" | 54618 | 54575 |
| | 6" | 54619 | 54576 |
| | 7" | 57521 | 57333 |
| | 8" | 57522 | 57334 |
| | 12" | 59129 | 59161 |
| | 1/4" | 57523 | 57335 |
| | 1/2" | 57524 | 57336 |
| | 3/4" | 57525 | 57337 |
| | 1" | 54620 | 54577 |
| | 1-1/4" | 54621 | 54578 |
| | 1-1/2" | 54622 | 54579 |
| | 1-3/4" | 57526 | 57338 |
| 2" | 54623 | 54580 | |
| 2-1/2" | 54624 | 54581 | |
| 3" | 54625 | 54582 | |
| 3-1/2" | 54626 | 54583 | |
| 4" | 54627 | 54584 | |
| 5" | 54629 | 54586 | |
| 6" | 54631 | 54588 | |
| 8" | 59130 | 59162 | |
| 12" | 59131 | 59163 | |
| 5/16" | 5/16" | 57527 | 57339 |
| | 1/2" | 57528 | 57340 |
| | 3/4" | 57529 | 57341 |
| | 1" | 54717 | 54632 |
| | 1-1/4" | 54718 | 54633 |
| | 1-1/2" | 54719 | 54634 |
| | 1-3/4" | 57530 | 57342 |
| | 2" | 54720 | 54635 |
| | 2-1/2" | 54721 | 54636 |
| 3" | 54722 | 54637 | |
| 3-1/2" | 54723 | 54638 | |
| 4" | 54724 | 54639 | |
| 5" | 54726 | 54641 | |
| 6" | 54727 | 54642 | |
| 8" | 59132 | 59164 | |

| 497 Air Hardening Precision Ground Flat Stock | | | |
|---|--------|--------|--------|
| Thickness | Width | 18" | 36" |
| | | Length | Length |
| 3/8" | 3/8" | 57531 | 57343 |
| | 1/2" | 57532 | 57344 |
| | 3/4" | 57533 | 57345 |
| | 1" | 54728 | 54643 |
| | 1-1/4" | 54729 | 54644 |
| | 1-1/2" | 54730 | 54645 |
| | 1-3/4" | 57534 | 57346 |
| | 2" | 54731 | 54646 |
| | 2-1/2" | 54732 | 54647 |
| | 3" | 54733 | 54648 |
| | 3-1/2" | 54734 | 54649 |
| | 4" | 54735 | 54650 |
| 1/2" | 5" | 54737 | 54652 |
| | 6" | 54739 | 54654 |
| | 8" | 59133 | 59165 |
| | 12" | 59134 | 59166 |
| | 1/2" | 56495 | 56505 |
| | 5/8" | 57535 | 57347 |
| | 3/4" | 56494 | 56506 |
| | 1" | 56493 | 56507 |
| | 1-1/4" | 57536 | 57348 |
| | 1-1/2" | 57537 | 57349 |
| | 1-3/4" | 57538 | 57350 |
| | 2" | 54748 | 54663 |
| 2-1/2" | 54749 | 54664 | |
| 3" | 54750 | 54665 | |
| 3-1/2" | 54751 | 54666 | |
| 4" | 54752 | 54667 | |
| 5" | 54754 | 54669 | |
| 6" | 54755 | 54670 | |
| 8" | 54757 | 54672 | |
| 12" | 59135 | 59167 | |
| 5/8" | 5/8" | 56499 | 56508 |
| | 3/4" | 56498 | 56509 |
| | 1" | 56497 | 56510 |
| | 1-1/2" | 56496 | 56511 |
| | 2" | 54760 | 54675 |
| | 2-1/2" | 54761 | 54676 |
| | 3" | 54762 | 54677 |
| | 3-1/2" | 54763 | 54678 |
| | 4" | 54764 | 54679 |
| 5" | 54765 | 54680 | |
| 3/4" | 6" | 54766 | 54681 |
| | 8" | 59136 | 59168 |
| | 3/4" | 54770 | 54685 |
| | 1" | 56501 | 56512 |
| | 1-1/4" | 57539 | 57351 |
| | 1-1/2" | 56500 | 56513 |
| | 2" | 54771 | 54686 |
| | 2-1/2" | 54772 | 54687 |
| | 3" | 54773 | 54688 |
| 4" | 54775 | 54690 | |
| 5" | 54777 | 54692 | |
| 6" | 54778 | 54693 | |

| 497 Air Hardening Precision Ground Flat Stock | | | |
|---|--------|--------|--------|
| Thickness | Width | 18" | 36" |
| | | Length | Length |
| 7/8" | 7/8" | 54781 | 54696 |
| | 1" | 56503 | 56514 |
| | 1-1/2" | 56502 | 56515 |
| | 2" | 54782 | 54697 |
| | 2-1/2" | | 54698 |
| | 3" | 54784 | 54699 |
| 1" | 4" | 54785 | 54700 |
| | 6" | 54786 | 54701 |
| | 1" | 54787 | 54702 |
| | 1-1/4" | 57540 | 57352 |
| | 1-1/2" | 56504 | 56516 |
| | 2" | 54788 | 54703 |
| | 2-1/2" | 54789 | 54704 |
| | 3" | 54790 | 54705 |
| | 4" | 54792 | 54707 |
| | 5" | 54794 | 54709 |
| | 6" | 54795 | 54710 |
| | 1-1/4" | 1-1/4" | 54834 |
| 1-1/2" | | 57683 | 57686 |
| 2" | | 54835 | 57687 |
| 2-1/2" | | 54836 | 57688 |
| 3" | | 54837 | 57689 |
| 4" | | 54838 | 57690 |
| 1-1/2" | 5" | 54839 | 57691 |
| | 6" | 54840 | 57692 |
| | 1-1/2" | 54843 | 57693 |
| | 2" | 54844 | 57694 |
| | 2-1/2" | 54845 | 57695 |
| | 3" | 54846 | 57696 |
| 2" | 3-1/2" | 54847 | 57697 |
| | 4" | 54848 | 57698 |
| | 6" | 54850 | 57699 |
| | 2" | 54853 | 57700 |
| 2" | 2-1/2" | 54854 | 57701 |
| | 3" | 54855 | 57702 |
| 4" | 54857 | 57703 | |

FLAT STOCK AND DRILL ROD

Sizes other than listed priced on application

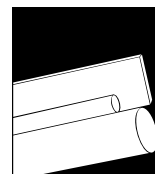

PRECISION GROUND FLAT STOCK

499 AIR HARDENING GROUND FLAT STOCK

OVERSIZE TOLERANCE

| 499 Air Hardening Ground Flat Stock | | | |
|-------------------------------------|--------|---------------|---------------|
| Thickness | Width | 18" Length | 36" Length |
| 1/8" | 1/2" | 57541 | 57353 |
| | 5/8" | 57542 | 57354 |
| | 3/4" | 57543 | 57355 |
| | 1" | 57544 | 57356 |
| | 1-1/4" | 57545 | 57357 |
| | 1-1/2" | 57546 | 57358 |
| | 1-3/4" | 57547 | 57359 |
| | 2" | 57548 | 57360 |
| | 2-1/2" | 57549 | 57361 |
| | 3" | 57550 | 57362 |
| | 3-1/2" | 57551 | 57363 |
| | 4" | 57552 | 57364 |
| 5" | 57553 | 57365 | |
| 6" | 57554 | 57366 | |
| 7" | 57555 | 57367 | |
| 8" | 57556 | 57368 | |
| 10" | 57557 | 57369 | |
| 12" | 57558 | 57370 | |
| 5/32" | 1/2" | 57559 | 57371 |
| | 3/4" | 57560 | 57372 |
| | 1" | 57561 | 57373 |
| | 1-1/4" | 57562 | 57374 |
| | 1-1/2" | 57563 | 57375 |
| | 2" | 57564 | 57376 |
| | 2-1/2" | 57565 | 57377 |
| | 3" | 57566 | 57378 |
| | 4" | 57567 | 57379 |
| | 5" | 57568 | 57380 |
| | 6" | 57569 | 57381 |
| | 8" | 57570 | 57382 |
| 3/16" | 3/16" | 57571 | 57383 |
| | 1/2" | 57572 | 57384 |
| | 3/4" | 57573 | 57385 |
| | 1" | 57162 | 56896 |
| | 1-1/4" | 57163 | 56897 |
| | 1-1/2" | 57164 | 56898 |
| | 1-3/4" | 57574 | 57386 |
| | 2" | 57165 | 56899 |
| | 2-1/2" | 57166 | 56900 |
| | 3" | 57167 | 56901 |
| | 3-1/2" | 57575 | 57387 |
| | 4" | 57168 | 56902 |
| 5" | 57576 | 57388 | |
| 6" | 57577 | 57389 | |
| 8" | 57578 | 57390 | |
| 10" | 57579 | 57391 | |

| 499 Air Hardening Ground Flat Stock | | | |
|-------------------------------------|--------|---------------|---------------|
| Thickness | Width | 18" Length | 36" Length |
| 1/4" | 1/4" | 57580 | 57392 |
| | 3/8" | | 58906 |
| | 1/2" | 57581 | 57393 |
| | 3/4" | 57582 | 57394 |
| | 1" | 57169 | 56903 |
| | 1-1/4" | 57170 | 56904 |
| | 1-1/2" | 57171 | 56905 |
| | 1-3/4" | 57583 | 57395 |
| | 2" | 57172 | 56906 |
| | 2-1/2" | 57173 | 56907 |
| | 3" | 57174 | 56908 |
| | 3-1/2" | 57584 | 57396 |
| 4" | 57175 | 56909 | |
| 5" | 57176 | 56910 | |
| 6" | 57177 | 56911 | |
| 7" | 57585 | 57397 | |
| 8" | 57586 | 57398 | |
| 10" | 57587 | 57399 | |
| 12" | 57588 | 57400 | |
| 5/16" | 5/16" | 57589 | 57401 |
| | 1/2" | 57590 | 57402 |
| | 3/4" | 57591 | 57403 |
| | 1" | 57178 | 56912 |
| | 1-1/4" | 57179 | 56913 |
| | 1-1/2" | 57180 | 56914 |
| | 1-3/4" | 57592 | 57404 |
| | 2" | 57181 | 56915 |
| | 2-1/2" | 57593 | 57405 |
| | 3" | 57182 | 56916 |
| | 3-1/2" | 57594 | 57406 |
| | 4" | 57183 | 56917 |
| 5" | 57184 | 56918 | |
| 6" | 57595 | 57407 | |
| 8" | 57596 | 57408 | |
| 3/8" | 3/8" | 57597 | 57409 |
| | 1/2" | 57598 | 57410 |
| | 3/4" | 57599 | 57411 |
| | 1" | 57185 | 56919 |
| | 1-1/4" | 57186 | 56920 |
| | 1-1/2" | 57187 | 56921 |
| | 1-3/4" | 57600 | 57412 |
| | 2" | 57188 | 56922 |
| | 2-1/2" | 57189 | 56923 |
| | 3" | 57190 | 56924 |
| | 3-1/2" | 57191 | 56925 |
| | 4" | 57192 | 56926 |
| 4-1/2" | 57601 | 57413 | |
| 5" | 57193 | 56927 | |
| 6" | 57194 | 56928 | |
| 7" | 57602 | 57414 | |
| 8" | 57603 | 57415 | |
| 10" | 57604 | 57416 | |
| 12" | 57605 | 57417 | |

| 499 Air Hardening Ground Flat Stock | | | |
|-------------------------------------|--------|---------------|---------------|
| Thickness | Width | 18" Length | 36" Length |
| 1/2" | 1/2" | 57195 | 56929 |
| | 5/8" | 57606 | 57418 |
| | 3/4" | 57196 | 56930 |
| | 1" | 57197 | 56931 |
| | 1-1/4" | 57607 | 57419 |
| | 1-1/2" | 57608 | 57420 |
| | 1-3/4" | 57609 | 57421 |
| | 2" | 57198 | 56932 |
| | 2-1/2" | 57199 | 56933 |
| | 3" | 57200 | 56934 |
| | 3-1/2" | 57201 | 56935 |
| | 4" | 57202 | 56936 |
| 4-1/2" | 57610 | 57422 | |
| 5" | 57203 | 56937 | |
| 6" | 57204 | 56938 | |
| 7" | 57611 | 57423 | |
| 8" | 57612 | 57424 | |
| 10" | 57613 | 57425 | |
| 12" | 57614 | 57426 | |
| 9/16" | 2" | 57615 | 57427 |
| | 2-1/2" | 57616 | 57428 |
| | 3" | 57617 | 57429 |
| | 4" | 57618 | 57430 |
| 5/8" | 5/8" | 57205 | 56939 |
| | 3/4" | 57206 | 56940 |
| | 1" | 57207 | 56941 |
| | 1-1/4" | 57619 | 57431 |
| | 1-1/2" | 57208 | 56942 |
| | 2" | 57209 | 56943 |
| | 2-1/2" | 57210 | 56944 |
| | 3" | 57211 | 56945 |
| | 3-1/2" | 57212 | 56946 |
| | 4" | 57620 | 57432 |
| | 5" | 57621 | 57433 |
| | 6" | 57622 | 57434 |
| 8" | 57623 | 57435 | |
| 10" | 57624 | 57436 | |
| 3/4" | 3/4" | 57213 | 56947 |
| | 1" | 57214 | 56948 |
| | 1-1/4" | 57625 | 57437 |
| | 1-1/2" | 57215 | 56949 |
| | 1-3/4" | 57626 | 57438 |
| | 2" | 57216 | 56950 |
| | 2-1/2" | 57627 | 57439 |
| | 3" | 57217 | 56951 |
| | 3-1/2" | 57628 | 57440 |
| | 4" | 57218 | 56952 |
| | 4-1/2" | 57629 | 57441 |
| | 5" | 57630 | 57442 |
| 6" | 57631 | 57443 | |
| 8" | 57632 | 57444 | |
| 10" | 57633 | 57445 | |
| 12" | 57634 | 57446 | |

| 499 Air Hardening Ground Flat Stock | | | |
|-------------------------------------|--------|---------------|---------------|
| Thickness | Width | 18" Length | 36" Length |
| 7/8" | 7/8" | 57635 | 57447 |
| | 1" | 57636 | 57448 |
| | 1-1/4" | 57637 | 57449 |
| | 1-1/2" | 57638 | 57450 |
| | 2" | 57639 | 57451 |
| | 2-1/2" | 57640 | 57452 |
| 1" | 3" | 57641 | 57453 |
| | 3-1/2" | 57642 | 57454 |
| | 4" | 57643 | 57455 |
| | 5" | 57644 | 57456 |
| | 6" | 57645 | 57457 |
| | 1" | 57219 | 56953 |
| | 1-1/4" | 57646 | 57458 |
| | 1-1/2" | 57220 | 56954 |
| | 1-3/4" | 57647 | 57459 |
| | 2" | 57221 | 56955 |
| | 2-1/2" | 57648 | 57460 |
| | 3" | 57222 | 56956 |
| 3-1/2" | 57649 | 57461 | |
| 4" | 57650 | 57462 | |
| 4-1/2" | 57651 | 57463 | |
| 5" | 57652 | 57464 | |
| 6" | 57653 | 57465 | |
| 8" | 57654 | 57466 | |
| 12" | 57655 | 57467 | |
| 1-1/4" | 1-1/4" | 57656 | 57468 |
| | 1-1/2" | 57657 | 57469 |
| | 2" | 57658 | 57470 |
| | 2-1/2" | 57659 | 57471 |
| | 3" | 57660 | 57472 |
| | 4" | 57661 | 57473 |
| 1-1/2" | 5" | 57662 | 57474 |
| | 6" | 57663 | 57475 |
| | 1-1/2" | 57664 | 57476 |
| | 2" | 57665 | 57477 |
| | 2-1/2" | 57666 | 57478 |
| | 3" | 57667 | 57479 |
| 2" | 3-1/2" | 57668 | 57480 |
| | 4" | 57669 | 57481 |
| | 6" | 57670 | 57482 |
| | 8" | 59137 | 59169 |
| | 12" | 59138 | 59170 |
| | 2" | 2" | 57671 |
| 2-1/2" | 2-1/2" | 57672 | 57484 |
| | 3" | 57673 | 57485 |
| | 4" | 57674 | 57486 |
| 3" | 2-1/2" | 57675 | 57487 |
| | 3" | 57676 | 57488 |

499, 1-1/4" and over is Blanchard ground with saw cut edges
 Sizes other than listed priced on application

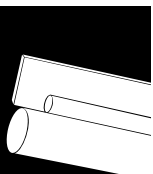

PRECISION GROUND FLAT STOCK

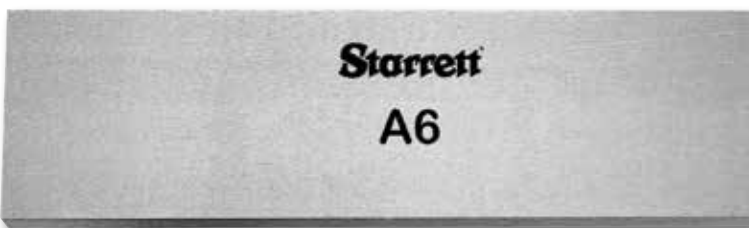

Heat Treatment and Tempering Data available upon request

344 A6 AIR HARDENING PRECISION GROUND FLAT STOCK

A6 is a medium alloyed air hardening tool steel that provides an excellent balance of machinability, toughness and wear resistance. Its lower heat treating temperature, which is similar to that of oil hardening steel, results in deep hardness and minimum distortion.

SPECIFICATIONS

Furnished in 36" lengths, ground straight and parallel.

NOMINAL ANALYSIS (AISI A6)

| | |
|------------------|------|
| Carbon | .70 |
| Chromium | 1.00 |
| Manganese | 2.00 |
| Molybdenum | 1.25 |
| Vanadium | - |
| Tungsten | - |

FLAT STOCK AND DRILL ROD

344 AIR HARDENING PRECISION GROUND FLAT STOCK

| 344 Air Hardening Precision Ground Flat Stock | | |
|---|--------|------------|
| Thickness | Width | 36" Length |
| 1/16" | 1/4" | 58907 |
| | 5/16" | 58908 |
| | 3/8" | 58909 |
| | 1/2" | 58910 |
| | 5/8" | 58911 |
| | 3/4" | 58912 |
| | 7/8" | 58913 |
| | 1" | 58914 |
| | 1-1/4" | 58915 |
| | 1-1/2" | 58916 |
| | 1-3/4" | 58917 |
| | 2" | 58918 |
| | 2-1/2" | 58919 |
| | 3" | 58920 |
| 3-1/2" | 58921 | |
| 4" | 58922 | |
| 5" | 58923 | |
| 6" | 58924 | |
| 3/32" | 1/4" | 58925 |
| | 5/16" | 58926 |
| | 3/8" | 58927 |
| | 1/2" | 58928 |
| | 5/8" | 58929 |
| | 3/4" | 58930 |
| | 7/8" | 58931 |
| | 1" | 58932 |
| | 1-1/4" | 58933 |
| | 1-1/2" | 58934 |
| | 1-3/4" | 58935 |
| | 2" | 58936 |
| | 2-1/2" | 58937 |
| | 3" | 58938 |
| 3-1/2" | 58939 | |
| 4" | 58940 | |
| 5" | 58941 | |
| 6" | 58942 | |

| 344 Air Hardening Precision Ground Flat Stock | | | |
|---|--------|------------|-------|
| Thickness | Width | 36" Length | |
| 1/8" | 1/4" | 58943 | |
| | 5/16" | 58944 | |
| | 3/8" | 58945 | |
| | 1/2" | 58946 | |
| | 5/8" | 58947 | |
| | 3/4" | 58948 | |
| | 7/8" | 58949 | |
| | 1" | 58950 | |
| | 1-1/4" | 58951 | |
| | 1-1/2" | 58952 | |
| | 1-3/4" | 58953 | |
| | 2" | 58954 | |
| 3/16" | 2-1/2" | 58955 | |
| | 3" | 58956 | |
| | 3-1/2" | 58957 | |
| | 4" | 58958 | |
| | 5" | 58959 | |
| | 6" | 58960 | |
| | 7" | 58961 | |
| | 8" | 58962 | |
| | 10" | 58963 | |
| | 12" | 58964 | |
| | 1/2" | 3/16" | 58965 |
| | | 1/4" | 58966 |
| 5/16" | | 58967 | |
| 3/8" | | 58968 | |
| 1/2" | | 58969 | |
| 5/8" | | 58970 | |
| 3/4" | | 58971 | |
| 7/8" | | 58972 | |
| 1" | | 58973 | |
| 1-1/4" | | 58974 | |
| 1-1/2" | | 58975 | |
| 1-3/4" | | 58976 | |
| 2" | | 58977 | |
| 2-1/2" | | 58978 | |
| 3" | | 58979 | |
| 3-1/2" | | 58980 | |
| 4" | | 58981 | |
| 5" | | 58982 | |
| 6" | | 58983 | |
| 7" | | 58984 | |
| 8" | 58985 | | |
| 10" | 58986 | | |
| 12" | 58987 | | |

| 344 Air Hardening Precision Ground Flat Stock | | | |
|---|--------|------------|-------|
| Thickness | Width | 36" Length | |
| 1/4" | 1/4" | 58988 | |
| | 5/16" | 58989 | |
| | 3/8" | 58990 | |
| | 1/2" | 58991 | |
| | 5/8" | 58992 | |
| | 3/4" | 58993 | |
| | 7/8" | 58994 | |
| | 1" | 58995 | |
| | 1-1/4" | 58996 | |
| | 1-1/2" | 58997 | |
| | 1-3/4" | 58998 | |
| | 2" | 58999 | |
| 3/8" | 2-1/2" | 59000 | |
| | 3" | 59001 | |
| | 3-1/2" | 59002 | |
| | 4" | 59003 | |
| | 5" | 59004 | |
| | 6" | 59005 | |
| | 7" | 59006 | |
| | 8" | 59007 | |
| | 10" | 59008 | |
| | 12" | 59009 | |
| | 1/2" | 5/16" | 59010 |
| | | 3/8" | 59011 |
| 1/2" | | 59012 | |
| 5/8" | | 59013 | |
| 3/4" | | 59014 | |
| 7/8" | | 59015 | |
| 1" | | 59016 | |
| 1-1/4" | | 59017 | |
| 1-1/2" | | 59018 | |
| 1-3/4" | | 59019 | |
| 2" | | 59020 | |
| 2-1/2" | | 59021 | |
| 3" | 59022 | | |
| 3/4" | 3-1/2" | 59023 | |
| | 4" | 59024 | |
| | 4-1/2" | 59025 | |
| | 5" | 59026 | |
| | 5-1/2" | 59027 | |
| | 6" | 59028 | |
| | 8" | 59029 | |
| | 10" | 59030 | |
| | 12" | 59031 | |

Sizes other than listed priced on application

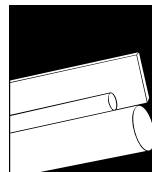

PRECISION GROUND FLAT STOCK

344 AIR HARDENING PRECISION GROUND FLAT STOCK

CONTINUED

| 344 Air Hardening Precision Ground Flat Stock | | |
|---|--------|------------|
| Thickness | Width | 36" Length |
| 3/8" | 3/8" | 59032 |
| | 1/2" | 59033 |
| | 5/8" | 59034 |
| | 3/4" | 59035 |
| | 7/8" | 59036 |
| | 1" | 59037 |
| | 1-1/4" | 59038 |
| | 1-1/2" | 59039 |
| | 1-3/4" | 59040 |
| | 2" | 59041 |
| | 2-1/2" | 59042 |
| | 3" | 59043 |
| | 3-1/2" | 59044 |
| | 4" | 59045 |
| | 4-1/2" | 59046 |
| 5" | 59047 | |
| 6" | 59048 | |
| 7" | 59049 | |
| 8" | 59050 | |
| 10" | 59051 | |
| 12" | 59052 | |
| 1/2" | 1/2" | 59053 |
| | 5/8" | 59054 |
| | 3/4" | 59055 |
| | 7/8" | 59056 |
| | 1" | 59057 |
| | 1-1/4" | 59058 |
| | 1-1/2" | 59059 |
| | 1-3/4" | 59060 |
| | 2" | 59061 |
| | 2-1/2" | 59062 |
| | 3" | 59063 |
| | 3-1/2" | 59064 |
| | 4" | 59065 |
| | 4-1/2" | 59066 |
| | 5" | 59067 |
| 5-1/2" | 59068 | |
| 6" | 59069 | |
| 7" | 59070 | |
| 8" | 59071 | |
| 10" | 59072 | |
| 12" | 59073 | |
| 5/8" | 5/8" | 59074 |
| | 3/4" | 59075 |
| | 7/8" | 59076 |
| | 1" | 59077 |
| | 1-1/4" | 59078 |
| | 1-1/2" | 59079 |
| | 1-3/4" | 59080 |
| | 2" | 59081 |
| | 2-1/2" | 59082 |
| | 3" | 59083 |
| | 3-1/2" | 59084 |
| | 4" | 59085 |
| | 4-1/2" | 59086 |
| | 5" | 59087 |
| | 5-1/2" | 59088 |
| 6" | 59089 | |
| 7" | 59090 | |
| 8" | 59091 | |
| 10" | 59092 | |

| 344 Air Hardening Precision Ground Flat Stock | | |
|---|--------|------------|
| Thickness | Width | 36" Length |
| 3/4" | 3/4" | 59093 |
| | 7/8" | 59094 |
| | 1" | 59095 |
| | 1-1/4" | 59096 |
| | 1-1/2" | 59097 |
| | 1-3/4" | 59098 |
| | 2" | 59099 |
| | 2-1/2" | 59100 |
| | 3" | 59101 |
| | 3-1/2" | 59102 |
| | 4" | 59103 |
| | 4-1/2" | 59104 |
| | 5" | 59105 |
| | 5-1/2" | 59106 |
| | 6" | 59107 |
| 7" | 59108 | |
| 8" | 59109 | |
| 10" | 59110 | |
| 1" | 1" | 59111 |
| | 1-1/4" | 59112 |
| | 1-1/2" | 59113 |
| | 1-3/4" | 59114 |
| | 2" | 59115 |
| | 2-1/2" | 59116 |
| | 3" | 59117 |
| | 3-1/2" | 59118 |
| | 4" | 59119 |
| | 4-1/2" | 59120 |
| | 5" | 59121 |
| | 5-1/2" | 59122 |
| | 6" | 59123 |
| | 7" | 59124 |
| | 8" | 59125 |
| 10" | 59126 | |

Sizes other than listed priced on application

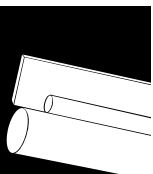

PRECISION GROUND FLAT STOCK



401 AND 402 HIGH CARBON, HIGH CHROMIUM PRECISION GROUND FLAT STOCK

- High carbon, high chromium steel
- For applications that demand the highest wear resistance
- 401 is standard tolerance
- 402 is oversize tolerance

SPECIFICATIONS

Furnished in 18" and 36" lengths, ground straight and parallel.

FLAT STOCK AND DRILL ROD

401 HIGH CARBON, HIGH CHROMIUM PRECISION GROUND FLAT STOCK

STANDARD TOLERANCE

| 401 High Carbon, High Chromium Precision Ground Flat Stock | | | |
|--|--------|------------|------------|
| Thickness | Width | 18" Length | 36" Length |
| 1/16" | 1/2" | 69097 | 69232 |
| | 3/4" | 69098 | 69233 |
| | 1" | 69099 | 69234 |
| | 1-1/4" | 69100 | 69235 |
| | 1-1/2" | 69101 | 69236 |
| | 2" | 69102 | 69237 |
| | 2-1/2" | 69103 | 69238 |
| | 3" | 69104 | 69239 |
| | 4" | 69105 | 69240 |
| 3/32" | 1/2" | 69108 | 69243 |
| | 3/4" | 69109 | 69244 |
| | 1" | 69110 | 69245 |
| | 1-1/4" | 69111 | 69246 |
| | 1-1/2" | 69112 | 69247 |
| | 2" | 69113 | 69248 |
| | 2-1/2" | 69114 | 69249 |
| | 3" | 69115 | 69250 |
| | 4" | 69116 | 69251 |
| 1/8" | 1/2" | 69119 | 69254 |
| | 3/4" | 69120 | 69255 |
| | 1" | 69121 | 69256 |
| | 1-1/4" | 69122 | 69257 |
| | 1-1/2" | 69123 | 69258 |
| | 2" | 69124 | 69259 |
| | 2-1/2" | 69125 | 69260 |
| | 3" | 69126 | 69261 |
| | 4" | 69127 | 69262 |
| 5/32" | 1/2" | 69130 | 69265 |
| | 3/4" | 69131 | 69266 |
| | 1" | 69132 | 69267 |
| | 1-1/4" | 69133 | 69268 |
| | 1-1/2" | 69134 | 69269 |
| | 2" | 69135 | 69270 |
| | 2-1/2" | 69136 | 69271 |
| | 3" | 69137 | 69272 |
| | 4" | 69138 | 69273 |

| 401 High Carbon, High Chromium Precision Ground Flat Stock | | | |
|--|--------|------------|------------|
| Thickness | Width | 18" Length | 36" Length |
| 3/16" | 1/2" | 69141 | 69276 |
| | 3/4" | 69142 | 69277 |
| | 1" | 69143 | 69278 |
| | 1-1/4" | 69144 | 69279 |
| | 1-1/2" | 69145 | 69280 |
| | 2" | 69146 | 69281 |
| | 2-1/2" | 69147 | 69282 |
| | 3" | 69148 | 69283 |
| | 4" | 69149 | 69284 |
| 1/4" | 1/2" | 69152 | 69287 |
| | 3/4" | 69153 | 69288 |
| | 1" | 69154 | 69289 |
| | 1-1/4" | 69155 | 69290 |
| | 1-1/2" | 69156 | 69291 |
| | 2" | 69157 | 69292 |
| | 2-1/2" | 69158 | 69293 |
| | 3" | 69159 | 69294 |
| | 4" | 69160 | 69295 |
| 5/16" | 1/2" | 69163 | 69298 |
| | 3/4" | 69164 | 69299 |
| | 1" | 69165 | 69300 |
| | 1-1/4" | 69166 | 69301 |
| | 1-1/2" | 69167 | 69302 |
| | 2" | 69168 | 69303 |
| | 2-1/2" | 69169 | 69304 |
| | 3" | 69170 | 69305 |
| | 4" | 69171 | 69306 |
| 3/8" | 1/2" | 69174 | 69309 |
| | 3/4" | 69175 | 69310 |
| | 1" | 69176 | 69311 |
| | 1-1/4" | 69177 | 69312 |
| | 1-1/2" | 69178 | 69313 |
| | 2" | 69179 | 69314 |
| | 2-1/2" | 69180 | 69315 |
| | 3" | 69181 | 69316 |
| | 4" | 69182 | 69317 |

| 401 High Carbon, High Chromium Precision Ground Flat Stock | | | |
|--|--------|------------|------------|
| Thickness | Width | 18" Length | 36" Length |
| 1/2" | 3/4" | 69185 | 69320 |
| | 1" | 69186 | 69321 |
| | 1-1/4" | 69187 | 69322 |
| | 1-1/2" | 69188 | 69323 |
| | 2" | 69189 | 69324 |
| | 2-1/2" | 69190 | 69325 |
| | 3" | 69191 | 69326 |
| | 4" | 69192 | 69327 |
| | 5" | 69193 | 69328 |
| 5/8" | 3/4" | 69195 | 69330 |
| | 1" | 69196 | 69331 |
| | 1-1/4" | 69197 | 69332 |
| | 1-1/2" | 69198 | 69333 |
| | 2" | 69199 | 69334 |
| | 2-1/2" | 69200 | 69335 |
| | 3" | 69201 | 69336 |
| | 4" | 69202 | 69337 |
| | 5" | 69203 | 69338 |
| 3/4" | 3/4" | 69204 | 69339 |
| | 1" | 69205 | 69340 |
| | 1-1/4" | 69206 | 69341 |
| | 1-1/2" | 69207 | 69342 |
| | 2" | 69208 | 69343 |
| | 2-1/2" | 69209 | 69344 |
| | 3" | 69210 | 69345 |
| | 4" | 69211 | 69346 |
| | 5" | 69212 | 69347 |
| 7/8" | 3/4" | 69213 | 69348 |
| | 1" | 69214 | 69349 |
| | 1-1/4" | 69215 | 69350 |
| | 1-1/2" | 69216 | 69351 |
| | 2" | 69217 | 69352 |
| | 2-1/2" | 69218 | 69353 |
| | 3" | 69219 | 69354 |
| | 4" | 69220 | 69355 |
| | 5" | 69221 | 69356 |
| 1" | 3/4" | 69222 | 69357 |
| | 1" | 69223 | 69358 |
| | 1-1/4" | 69224 | 69359 |
| | 1-1/2" | 69225 | 69360 |
| | 2" | 69226 | 69361 |
| | 2-1/2" | 69227 | 69362 |
| | 3" | 69228 | 69363 |
| | 4" | 69229 | 69364 |
| | 5" | 69230 | 69365 |
| 6" | 69231 | 69366 | |

Sizes other than listed priced on application

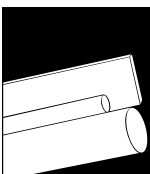

PRECISION GROUND FLAT STOCK

402 HIGH CARBON, HIGH CHROMIUM GROUND FLAT STOCK

OVERSIZE TOLERANCE

| 402 High Carbon, High Chromium Ground Flat Stock | | | |
|--|--------|------------|------------|
| Thickness | Width | 18" Length | 36" Length |
| 1/8" | 1/2" | 69367 | 69481 |
| | 3/4" | 69368 | 69482 |
| | 1" | 69369 | 69483 |
| | 1-1/4" | 69370 | 69484 |
| | 1-1/2" | 69371 | 69485 |
| | 2" | 69372 | 69486 |
| | 2-1/2" | 69373 | 69487 |
| | 3" | 69374 | 69488 |
| | 4" | 69375 | 69489 |
| | 5" | 69376 | 69490 |
| 6" | 69377 | 69491 | |
| 5/32" | 1/2" | 69378 | 69492 |
| | 3/4" | 69379 | 69493 |
| | 1" | 69380 | 69494 |
| | 1-1/4" | 69381 | 69495 |
| | 1-1/2" | 69382 | 69496 |
| | 2" | 69383 | 69497 |
| | 2-1/2" | 69384 | 69498 |
| | 3" | 69385 | 69499 |
| | 4" | 69386 | 69500 |
| | 5" | 69387 | 69501 |
| 6" | 69388 | 69502 | |
| 3/16" | 1/2" | 69389 | 69503 |
| | 3/4" | 69390 | 69504 |
| | 1" | 69391 | 69505 |
| | 1-1/4" | 69392 | 69506 |
| | 1-1/2" | 69393 | 69507 |
| | 2" | 69394 | 69508 |
| | 2-1/2" | 69395 | 69509 |
| | 3" | 69396 | 69510 |
| | 4" | 69397 | 69511 |
| | 5" | 69398 | 69512 |
| 6" | 69399 | 69513 | |
| 1/4" | 1/2" | 69400 | 69514 |
| | 3/4" | 69401 | 69515 |
| | 1" | 69402 | 69516 |
| | 1-1/4" | 69403 | 69517 |
| | 1-1/2" | 69404 | 69518 |
| | 2" | 69405 | 69519 |
| | 2-1/2" | 69406 | 69520 |
| | 3" | 69407 | 69521 |
| | 4" | 69408 | 69522 |
| | 5" | 69409 | 69523 |
| 6" | 69410 | 69524 | |
| 5/16" | 1/2" | 69411 | 69525 |
| | 3/4" | 69412 | 69526 |
| | 1" | 69413 | 69527 |
| | 1-1/4" | 69414 | 69528 |
| | 1-1/2" | 69415 | 69529 |
| | 2" | 69416 | 69530 |
| | 2-1/2" | 69417 | 69531 |
| | 3" | 69418 | 69532 |
| | 4" | 69419 | 69533 |
| | 5" | 69420 | 69534 |
| 6" | 69421 | 69535 | |

| 402 High Carbon, High Chromium Ground Flat Stock | | | |
|--|--------|------------|------------|
| Thickness | Width | 18" Length | 36" Length |
| 3/8" | 1/2" | 69422 | 69536 |
| | 3/4" | 69423 | 69537 |
| | 1" | 69424 | 69538 |
| | 1-1/4" | 69425 | 69539 |
| | 1-1/2" | 69426 | 69540 |
| | 2" | 69427 | 69541 |
| | 2-1/2" | 69428 | 69542 |
| | 3" | 69429 | 69543 |
| | 4" | 69430 | 69544 |
| | 5" | 69431 | 69545 |
| 6" | 69432 | 69546 | |
| 1/2" | 1/2" | 69433 | 69547 |
| | 3/4" | 69434 | 69548 |
| | 1" | 69435 | 69549 |
| | 1-1/4" | 69436 | 69550 |
| | 1-1/2" | 69437 | 69551 |
| | 2" | 69438 | 69552 |
| | 2-1/2" | 69439 | 69553 |
| | 3" | 69440 | 69554 |
| | 4" | 69441 | 69555 |
| | 5" | 69442 | 69556 |
| 6" | 69443 | 69557 | |
| 5/8" | 5/8" | 69444 | 69558 |
| | 3/4" | 69445 | 69559 |
| | 1" | 69446 | 69560 |
| | 1-1/4" | 69447 | 69561 |
| | 1-1/2" | 69448 | 69562 |
| | 2" | 69449 | 69563 |
| | 2-1/2" | 69450 | 69564 |
| | 3" | 69451 | 69565 |
| | 4" | 69452 | 69566 |
| | 5" | 69453 | 69567 |
| 6" | 69454 | 69568 | |
| 3/4" | 3/4" | 69455 | 69569 |
| | 1" | 69456 | 69570 |
| | 1-1/4" | 69457 | 69571 |
| | 1-1/2" | 69458 | 69572 |
| | 2" | 69459 | 69573 |
| | 2-1/2" | 69460 | 69574 |
| | 3" | 69461 | 69575 |
| | 4" | 69462 | 69576 |
| | 5" | 69463 | 69577 |
| | 6" | 69464 | 69578 |
| 7/8" | 7/8" | 69465 | 69579 |
| | 1" | 69466 | 69580 |
| | 1-1/2" | 69467 | 69581 |
| | 2" | 69468 | 69582 |
| | 3" | 69469 | 69583 |
| | 4" | 69470 | 69584 |
| 1" | 6" | 69471 | 69585 |
| | 1" | 69472 | 69586 |
| | 1-1/4" | 69473 | 69587 |
| | 1-1/2" | 69474 | 69588 |
| | 2" | 69475 | 69589 |
| | 2-1/2" | 69476 | 69590 |
| | 3" | 69477 | 69591 |
| | 4" | 69478 | 69592 |
| | 5" | 69479 | 69593 |
| | 6" | 69480 | 69594 |

Sizes other than listed priced on application

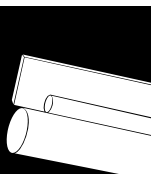

PRECISION GROUND FLAT STOCK



SPECIFICATIONS

Furnished in 24" lengths, ground straight and parallel.

ANALYSIS

Starrett 498 Low Carbon Precision Ground Flat Stock is a .20 carbon fine-grained, milled steel, which can be carburized or case hardened. Very similar to AISI 1018.

HEAT TREATMENT

For many applications, stock can be used unhardened. However, if surface hardening is desired, it can be carburized or case hardened. If carburized, a case of 1/32" will be obtained if the steel is held in carburizing salt at 1700° F for three hours.

498 LOW CARBON PRECISION GROUND FLAT STOCK

- Substantial cost reductions over tool steel ground flat stock. There are savings up to 60% because this is a low carbon steel and furnished in 24" lengths. This means that you get one-third more steel at less cost.
- Ideal for a wide variety of parts that don't require more expensive heat treated steels, such as stripper plates, jigs, fixtures, machine and component parts, templates, etc.
- This steel can be carburized or case hardened. After hardening, its physical properties, especially tensile strength, yield point, and Brinell hardness, are substantially higher.
- **NOTE:** Thicknesses of 1/8" and under are made from AISI 1010 material
- Starrett uses its own ground flat stock for many of its precision tool parts

FLAT STOCK AND DRILL ROD

498 LOW CARBON PRECISION GROUND FLAT STOCK

| 498 Low Carbon Precision Ground Flat Stock | | |
|--|--------|------------|
| Thickness | Width | 24" Length |
| 1/16" | 1/2" | 54866 |
| | 3/4" | 54867 |
| | 1" | 54868 |
| | 1-1/4" | 54869 |
| | 1-1/2" | 54870 |
| | 2" | 54871 |
| | 2-1/2" | 54872 |
| | 3" | 54873 |
| | 3-1/2" | 54874 |
| | 4" | 54875 |
| | 5" | 54876 |
| | 6" | 54877 |
| 3/32" | 1/2" | 54881 |
| | 3/4" | 54882 |
| | 1" | 54883 |
| | 1-1/4" | 54884 |
| | 1-1/2" | 54885 |
| | 2" | 54886 |
| | 2-1/2" | 54887 |
| | 3" | 54888 |
| | 3-1/2" | 58285 |
| | 4" | 54889 |
| | 5" | 54890 |
| | 6" | 54891 |
| 8" | 54892 | |
| 10" | 58286 | |
| 12" | 58287 | |

| 498 Low Carbon Precision Ground Flat Stock | | |
|--|--------|------------|
| Thickness | Width | 24" Length |
| 1/8" | 1/2" | 54893 |
| | 3/4" | 54894 |
| | 1" | 54895 |
| | 1-1/4" | 54896 |
| | 1-1/2" | 54897 |
| | 2" | 54898 |
| | 2-1/2" | 54899 |
| | 3" | 54900 |
| | 3-1/2" | 54901 |
| | 4" | 54902 |
| | 5" | 54903 |
| | 6" | 54904 |
| 5/32" | 1/2" | 54908 |
| | 3/4" | 54909 |
| | 1" | 54910 |
| | 1-1/4" | 54911 |
| | 1-1/2" | 54912 |
| | 2" | 54913 |
| | 2-1/2" | 54914 |
| | 3" | 54915 |
| | 3-1/2" | 58290 |
| | 4" | 54917 |
| | 5" | 54918 |
| | 6" | 54919 |
| 8" | 58291 | |
| 10" | 58292 | |
| 12" | 58293 | |

| 498 Low Carbon Precision Ground Flat Stock | | |
|--|--------|------------|
| Thickness | Width | 24" Length |
| 3/16" | 3/16" | 57247 |
| | 1/2" | 54921 |
| | 3/4" | 54922 |
| | 1" | 54923 |
| | 1-1/4" | 54924 |
| | 1-1/2" | 54925 |
| | 2" | 54926 |
| | 2-1/2" | 54927 |
| | 3" | 54928 |
| | 3-1/2" | 54929 |
| | 4" | 54930 |
| | 5" | 54931 |
| 1/4" | 6" | 54932 |
| | 8" | 54933 |
| | 10" | 54934 |
| | 12" | 57248 |
| | 1/4" | 57249 |
| | 1/2" | 54935 |
| | 3/4" | 54936 |
| | 1" | 54937 |
| | 1-1/4" | 54938 |
| | 1-1/2" | 54939 |
| | 2" | 54940 |
| | 2-1/2" | 54941 |
| 3" | 54942 | |
| 3-1/2" | 54943 | |
| 4" | 54944 | |
| 5" | 54945 | |
| 6" | 54946 | |
| 8" | 54947 | |
| 10" | 54948 | |
| 12" | 54949 | |

Sizes other than listed priced on application

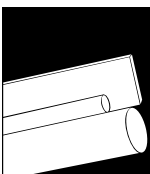

PRECISION GROUND FLAT STOCK

498 Low CARBON PRECISION GROUND FLAT STOCK

CONTINUED

| 498 Low Carbon Precision Ground Flat Stock | | | |
|--|--------|------------|-------|
| Thickness | Width | 24" Length | |
| 5/16" | 5/16" | 57250 | |
| | 1/2" | 54950 | |
| | 3/4" | 54951 | |
| | 1" | 54952 | |
| | 1-1/4" | 54953 | |
| | 1-1/2" | 54954 | |
| | 2" | 54955 | |
| | 2-1/2" | 54956 | |
| | 3" | 54957 | |
| | 3-1/2" | 54958 | |
| | 4" | 54959 | |
| | 5" | 54960 | |
| | 6" | 54961 | |
| 3/8" | 3/8" | 54964 | |
| | 1/2" | 54965 | |
| | 3/4" | 54966 | |
| | 1" | 54967 | |
| | 1-1/4" | 54968 | |
| | 1-1/2" | 54969 | |
| | 2" | 54970 | |
| | 2-1/2" | 54971 | |
| | 3" | 54972 | |
| | 3-1/2" | 54973 | |
| | 4" | 54974 | |
| | 5" | 54975 | |
| | 6" | 54976 | |
| 7/16" | 7/16" | 54982 | |
| | 1/2" | 54983 | |
| | 3/4" | 54984 | |
| | 1" | 54985 | |
| | 1-1/4" | 54986 | |
| | 1-1/2" | 54987 | |
| | 2" | 54988 | |
| | 2-1/2" | 54989 | |
| | 3" | 54990 | |
| | 3-1/2" | 54991 | |
| | 4" | 54992 | |
| | 5" | 54993 | |
| | 6" | 54994 | |
| 1/2" | 7" | 54995 | |
| | 8" | 54996 | |
| | 9" | 54997 | |
| | 10" | 54998 | |
| | 12" | 54999 | |
| | 9/16" | 9/16" | 55000 |

| 498 Low Carbon Precision Ground Flat Stock | | |
|--|--------|------------|
| Thickness | Width | 24" Length |
| 5/8" | 5/8" | 55001 |
| | 3/4" | 55002 |
| | 1" | 55003 |
| | 1-1/4" | 55004 |
| | 1-1/2" | 55005 |
| | 2" | 55006 |
| | 2-1/2" | 55007 |
| | 3" | 55008 |
| | 3-1/2" | 55009 |
| | 4" | 55010 |
| | 5" | 55011 |
| | 6" | 55012 |
| | 3/4" | 7" |
| 8" | | 55014 |
| 9" | | 55015 |
| 10" | | 55016 |
| 12" | | 57253 |
| 3/4" | | 55017 |
| 1" | | 55018 |
| 1-1/4" | | 55019 |
| 1-1/2" | | 55020 |
| 2" | | 55021 |
| 2-1/2" | | 55022 |
| 3" | | 55023 |
| 3-1/2" | | 55024 |
| 7/8" | 4" | 55025 |
| | 5" | 55026 |
| | 6" | 55027 |
| | 7" | 57254 |
| | 8" | 55028 |
| | 9" | 55029 |
| | 10" | 55030 |
| | 12" | 55031 |
| | 7/8" | 55032 |
| | 1" | 55033 |
| | 1-1/4" | 55034 |
| | 1-1/2" | 55035 |
| | 2" | 55036 |
| 2-1/2" | 55037 | |
| 1" | 3" | 55038 |
| | 3-1/2" | 57255 |
| | 4" | 55039 |
| | 6" | 55040 |
| | 1" | 55041 |
| | 1-1/4" | 55042 |
| | 1-1/2" | 55043 |
| | 2" | 55044 |
| | 2-1/2" | 55045 |
| | 3" | 55046 |
| | 3-1/2" | 55047 |
| | 4" | 55048 |
| | 5" | 55049 |
| 6" | 55050 | |
| 7" | 57256 | |
| 8" | 55051 | |
| 9" | 55052 | |
| 10" | 55053 | |
| 12" | 55054 | |
| 1-1/8" | 1-1/8" | 58288 |

| 498 Low Carbon Precision Ground Flat Stock | | | |
|--|--------|------------|-------|
| Thickness | Width | 24" Length | |
| 1-1/4" | 1-1/4" | 55055 | |
| | 1-1/2" | 55056 | |
| | 2" | 55057 | |
| | 2-1/2" | 55058 | |
| | 3" | 55059 | |
| | 4" | 55060 | |
| | 5" | 55061 | |
| | 6" | 55062 | |
| | 8" | 55063 | |
| | 10" | 55065 | |
| | 12" | 57257 | |
| | 1-1/2" | 1-1/2" | 55066 |
| | | 2" | 55067 |
| 2-1/2" | | 55068 | |
| 3" | | 55069 | |
| 3-1/2" | | 55070 | |
| 4" | | 55071 | |
| 5" | | 55072 | |
| 6" | | 55073 | |
| 8" | | 55074 | |
| 10" | | 55075 | |
| 2" | | 2" | 55076 |
| 2-1/2" | | 2-1/2" | 58289 |

Sizes other than listed priced on application

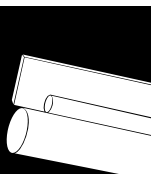



PRECISION DRILL ROD

O1 480 PRECISION GROUND AND POLISHED DRILL ROD

AISI/SAE O1 is a general purpose tool steel with good wear resistance, toughness and machinability.

NOMINAL ANALYSIS (AISI O1)

| | |
|-----------------|------|
| Carbon | .90 |
| Chromium | .50 |
| Manganese | 1.20 |
| Tungsten | .50 |
| Vanadium | .20 |

Heat Treatment and Tempering Data available upon request

| Tolerances | | |
|----------------------|----------|------------|
| Size Range | Diameter | Length |
| .124" round and less | ± .0003" | + 1/8" - 0 |
| .125" to .499" | ± .0005" | + 1/8" - 0 |
| .500" to 2" | ± .0010" | + 1/8" - 0 |

FLAT STOCK AND DRILL ROD

O1 480 PRECISION GROUND AND POLISHED DRILL ROD

| Letter Sizes | | |
|--------------|---------|------------|
| Diameter | Decimal | 36" Length |
| A | 0.2340 | 68201 |
| B | 0.2380 | 68202 |
| C | 0.2420 | 68203 |
| D | 0.2460 | 68204 |
| E | 0.2500 | 68205 |
| F | 0.2570 | 68206 |
| G | 0.2610 | 68207 |
| H | 0.2660 | 68208 |
| I | 0.2720 | 68209 |
| J | 0.2770 | 68210 |
| K | 0.2810 | 68211 |
| L | 0.2900 | 68212 |
| M | 0.2950 | 68213 |
| N | 0.3020 | 68214 |
| O | 0.3160 | 68215 |
| P | 0.3230 | 68216 |
| Q | 0.3320 | 68217 |
| R | 0.3390 | 68218 |
| S | 0.3480 | 68219 |
| T | 0.3580 | 68220 |
| U | 0.3680 | 68221 |
| V | 0.3770 | 68222 |
| W | 0.3860 | 68223 |
| X | 0.3970 | 68224 |
| Y | 0.4040 | 68225 |
| Z | 0.4130 | 68226 |

| Number Sizes | | |
|--------------|---------|------------|
| Diameter | Decimal | 36" Length |
| 52 | 0.0630 | 68251 |
| 51 | 0.0660 | 68252 |
| 50 | 0.0690 | 68253 |
| 49 | 0.0720 | 68254 |
| 48 | 0.0750 | 68255 |
| 47 | 0.0770 | 68256 |
| 46 | 0.0790 | 68257 |
| 45 | 0.0810 | 68258 |
| 44 | 0.0850 | 68259 |
| 43 | 0.0880 | 68260 |
| 42 | 0.0920 | 68261 |
| 41 | 0.0950 | 68262 |
| 40 | 0.0970 | 68263 |
| 39 | 0.0990 | 68264 |
| 38 | 0.1010 | 68265 |
| 37 | 0.1030 | 68266 |
| 36 | 0.1060 | 68267 |
| 35 | 0.1080 | 68268 |
| 34 | 0.1100 | 68269 |
| 33 | 0.1120 | 68270 |
| 32 | 0.1150 | 68271 |
| 31 | 0.1200 | 68272 |
| 30 | 0.1270 | 68273 |
| 29 | 0.1340 | 68274 |
| 28 | 0.1390 | 68275 |
| 27 | 0.1430 | 68276 |

| Number Sizes | | |
|--------------|---------|------------|
| Diameter | Decimal | 36" Length |
| 26 | 0.1460 | 68277 |
| 25 | 0.1480 | 68278 |
| 24 | 0.1510 | 68279 |
| 23 | 0.1530 | 68280 |
| 22 | 0.1550 | 68281 |
| 21 | 0.1570 | 68282 |
| 20 | 0.1610 | 68283 |
| 19 | 0.1640 | 68284 |
| 18 | 0.1680 | 68285 |
| 17 | 0.1720 | 68286 |
| 16 | 0.1750 | 68287 |
| 15 | 0.1780 | 68288 |
| 14 | 0.1800 | 68289 |
| 13 | 0.1820 | 68290 |
| 12 | 0.1850 | 68291 |
| 11 | 0.1880 | 68292 |
| 10 | 0.1910 | 68293 |
| 9 | 0.1940 | 68294 |
| 8 | 0.1970 | 68295 |
| 7 | 0.1990 | 68296 |
| 6 | 0.2010 | 68297 |
| 5 | 0.2040 | 68298 |
| 4 | 0.2070 | 68299 |
| 3 | 0.2120 | 68300 |
| 2 | 0.2190 | 68301 |
| 1 | 0.2270 | 68302 |

Sizes other than listed priced on application

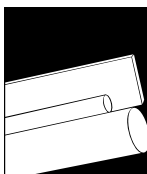

PRECISION DRILL ROD

01 480 PRECISION GROUND AND POLISHED DRILL ROD

CONTINUED

| Fractional Sizes | | |
|------------------|---------|------------|
| Diameter | | |
| in | Decimal | 36" Length |
| 1/16 | 0.0625 | 68303 |
| 5/64 | 0.0781 | 68304 |
| 3/32 | 0.0938 | 68305 |
| 7/64 | 0.1094 | 68306 |
| 1/8 | 0.1250 | 68307 |
| 9/64 | 0.1406 | 68308 |
| 5/32 | 0.1563 | 68309 |
| 11/64 | 0.1719 | 68310 |
| 3/16 | 0.1875 | 68311 |
| 13/64 | 0.2031 | 68312 |
| 7/32 | 0.2188 | 68313 |
| 15/64 | 0.2344 | 68314 |
| 1/4 | 0.2500 | 68315 |
| 17/64 | 0.2656 | 68316 |
| 9/32 | 0.2813 | 68317 |
| 19/64 | 0.2969 | 68318 |
| 5/16 | 0.3125 | 68319 |
| 21/64 | 0.3281 | 68320 |
| 11/32 | 0.3438 | 68321 |
| 23/64 | 0.3594 | 68322 |
| 3/8 | 0.3750 | 68323 |
| 25/64 | 0.3906 | 68324 |
| 13/32 | 0.4063 | 68325 |
| 27/64 | 0.4219 | 68326 |
| 7/16 | 0.4375 | 68327 |
| 29/64 | 0.4531 | 68328 |
| 15/32 | 0.4688 | 68329 |
| 31/64 | 0.4844 | 68330 |
| 1/2 | 0.5000 | 68331 |
| 33/64 | 0.5156 | 68332 |
| 17/32 | 0.5313 | 68333 |
| 35/64 | 0.5469 | 68334 |
| 9/16 | 0.5625 | 68335 |
| 37/64 | 0.5781 | 68336 |
| 19/32 | 0.5938 | 68337 |
| 39/64 | 0.6094 | 68338 |
| 5/8 | 0.6250 | 68339 |
| 41/64 | 0.6406 | 68340 |
| 21/32 | 0.6563 | 68341 |
| 43/64 | 0.6719 | 68342 |
| 11/16 | 0.6875 | 68343 |
| 45/64 | 0.7031 | 68344 |
| 23/32 | 0.7188 | 68345 |
| 47/64 | 0.7344 | 68346 |
| 3/4 | 0.7500 | 68347 |
| 49/64 | 0.7656 | 68348 |
| 25/32 | 0.7813 | 68349 |
| 51/64 | 0.7969 | 68350 |
| 13/16 | 0.8125 | 68351 |
| 53/64 | 0.8281 | 68352 |

| Fractional Sizes | | |
|------------------|---------|------------|
| Diameter | | |
| in | Decimal | 36" Length |
| 27/32 | 0.8438 | 68353 |
| 55/64 | 0.8594 | 68354 |
| 7/8 | 0.8750 | 68355 |
| 57/64 | 0.8906 | 68356 |
| 29/32 | 0.9063 | 68357 |
| 59/64 | 0.9219 | 68358 |
| 15/16 | 0.9375 | 68359 |
| 61/64 | 0.9531 | 68360 |
| 31/32 | 0.9688 | 68361 |
| 63/64 | 0.9844 | 68362 |
| 1 | 1.0000 | 68363 |
| 1-1/64 | 1.0156 | 68364 |
| 1-1/32 | 1.0313 | 68365 |
| 1-3/64 | 1.0469 | 68366 |
| 1-1/16 | 1.0625 | 68367 |
| 1-5/64 | 1.0781 | 68368 |
| 1-3/32 | 1.0938 | 68369 |
| 1-7/64 | 1.1094 | 68370 |
| 1-1/8 | 1.1250 | 68371 |
| 1-9/64 | 1.1406 | 68372 |
| 1-5/32 | 1.1563 | 68373 |
| 1-11/64 | 1.1719 | 68374 |
| 1-3/16 | 1.1875 | 68375 |
| 1-13/64 | 1.2031 | 68376 |
| 1-7/32 | 1.2188 | 68377 |
| 1-15/64 | 1.2344 | 68378 |
| 1-1/4 | 1.2500 | 68379 |
| 1-17/64 | 1.2656 | 68380 |
| 1-9/32 | 1.2813 | 68381 |
| 1-19/64 | 1.2969 | 68382 |
| 1-5/16 | 1.3125 | 68383 |
| 1-21/64 | 1.3281 | 68384 |
| 1-11/32 | 1.3438 | 68385 |
| 1-23/64 | 1.3594 | 68386 |
| 1-3/8 | 1.3750 | 68387 |
| 1-25/64 | 1.3906 | 68388 |
| 1-13/32 | 1.4063 | 68389 |
| 1-27/64 | 1.4219 | 68390 |
| 1-7/16 | 1.4375 | 68391 |
| 1-29/64 | 1.4531 | 68392 |
| 1-15/32 | 1.4688 | 68393 |
| 1-31/64 | 1.4844 | 68394 |
| 1-1/2 | 1.5000 | 68395 |
| 1-9/16 | 1.5625 | 68396 |
| 1-5/8 | 1.6250 | 68397 |
| 1-11/16 | 1.6875 | 68398 |
| 1-3/4 | 1.7500 | 68399 |
| 1-13/16 | 1.8125 | 68400 |
| 1-7/8 | 1.8750 | 68401 |
| 1-15/16 | 1.9375 | 68402 |
| 2 | 2.0000 | 68403 |

| Metric Sizes | | |
|--------------|---------|------------|
| Diameter | | |
| mm | Decimal | 36" Length |
| 2 | 0.0787 | 68227 |
| 3 | 0.1181 | 68228 |
| 4 | 0.1575 | 68229 |
| 5 | 0.1969 | 68230 |
| 6 | 0.2362 | 68231 |
| 7 | 0.2756 | 68232 |
| 8 | 0.3150 | 68233 |
| 9 | 0.3543 | 68234 |
| 10 | 0.3937 | 68235 |
| 11 | 0.4331 | 68236 |
| 12 | 0.4724 | 68237 |
| 13 | 0.5118 | 68238 |
| 14 | 0.5512 | 68239 |
| 15 | 0.5906 | 68240 |
| 16 | 0.6299 | 68241 |
| 17 | 0.6693 | 68242 |
| 18 | 0.7087 | 68243 |
| 19 | 0.7480 | 68244 |
| 20 | 0.7874 | 68245 |
| 21 | 0.8268 | 68246 |
| 22 | 0.8661 | 68247 |
| 23 | 0.9055 | 68248 |
| 24 | 0.9449 | 68249 |
| 25 | 0.9843 | 68250 |

Sizes other than listed priced on application

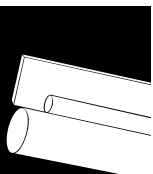



PRECISION DRILL ROD

W1 481 PRECISION GROUND AND POLISHED DRILL ROD

AISI/SAE W1 is a versatile and less expensive tool steel that has superior machinability and maintains good wear resistance and toughness characteristics.

NOMINAL ANALYSIS (AISI W1)

| | |
|-----------------|----------|
| Carbon | .90-1.05 |
| Manganese | .30-.50 |

Tolerances

| Size Range | Diameter | Length |
|----------------------|----------|------------|
| .124" round and less | ± .0003" | + 1/8" - 0 |
| .125" to .499" | ± .0005" | + 1/8" - 0 |
| .500" to 2" | ± .0010" | + 1/8" - 0 |

Heat Treatment and Tempering Data available upon request

FLAT STOCK AND DRILL ROD

W1 481 PRECISION GROUND AND POLISHED DRILL ROD

| Letter Sizes | | |
|--------------|---------|------------|
| Diameter | Decimal | 36" Length |
| A | 0.2340 | 68404 |
| B | 0.2380 | 68405 |
| C | 0.2420 | 68406 |
| D | 0.2460 | 68407 |
| E | 0.2500 | 68408 |
| F | 0.2570 | 68409 |
| G | 0.2610 | 68410 |
| H | 0.2660 | 68411 |
| I | 0.2720 | 68412 |
| J | 0.2770 | 68413 |
| K | 0.2810 | 68414 |
| L | 0.2900 | 68415 |
| M | 0.2950 | 68416 |
| N | 0.3020 | 68417 |
| O | 0.3160 | 68418 |
| P | 0.3230 | 68419 |
| Q | 0.3320 | 68420 |
| R | 0.3390 | 68421 |
| S | 0.3480 | 68422 |
| T | 0.3580 | 68423 |
| U | 0.3680 | 68424 |
| V | 0.3770 | 68425 |
| W | 0.3860 | 68426 |
| X | 0.3970 | 68427 |
| Y | 0.4040 | 68428 |
| Z | 0.4130 | 68429 |

| Number Sizes | | |
|--------------|---------|------------|
| Diameter | Decimal | 36" Length |
| 52 | 0.0630 | 68430 |
| 51 | 0.0660 | 68431 |
| 50 | 0.0690 | 68432 |
| 49 | 0.0720 | 68433 |
| 48 | 0.0750 | 68434 |
| 47 | 0.0770 | 68435 |
| 46 | 0.0790 | 68436 |
| 45 | 0.0810 | 68437 |
| 44 | 0.0850 | 68438 |
| 43 | 0.0880 | 68439 |
| 42 | 0.0920 | 68440 |
| 41 | 0.0950 | 68441 |
| 40 | 0.0970 | 68442 |
| 39 | 0.0990 | 68443 |
| 38 | 0.1010 | 68444 |
| 37 | 0.1030 | 68445 |
| 36 | 0.1060 | 68446 |
| 35 | 0.1080 | 68447 |
| 34 | 0.1100 | 68448 |
| 33 | 0.1120 | 68449 |
| 32 | 0.1150 | 68450 |
| 31 | 0.1200 | 68451 |
| 30 | 0.1270 | 68452 |
| 29 | 0.1340 | 68453 |
| 28 | 0.1390 | 68454 |
| 27 | 0.1430 | 68455 |

| Number Sizes | | |
|--------------|---------|------------|
| Diameter | Decimal | 36" Length |
| 26 | 0.1460 | 68456 |
| 25 | 0.1480 | 68457 |
| 24 | 0.1510 | 68458 |
| 23 | 0.1530 | 68459 |
| 22 | 0.1550 | 68460 |
| 21 | 0.1570 | 68461 |
| 20 | 0.1610 | 68462 |
| 19 | 0.1640 | 68463 |
| 18 | 0.1680 | 68464 |
| 17 | 0.1720 | 68465 |
| 16 | 0.1750 | 68466 |
| 15 | 0.1780 | 68467 |
| 14 | 0.1800 | 68468 |
| 13 | 0.1820 | 68469 |
| 12 | 0.1850 | 68470 |
| 11 | 0.1880 | 68471 |
| 10 | 0.1910 | 68472 |
| 9 | 0.1940 | 68473 |
| 8 | 0.1970 | 68474 |
| 7 | 0.1990 | 68475 |
| 6 | 0.2010 | 68476 |
| 5 | 0.2040 | 68477 |
| 4 | 0.2070 | 68478 |
| 3 | 0.2120 | 68479 |
| 2 | 0.2190 | 68480 |
| 1 | 0.2270 | 68481 |

Sizes other than listed priced on application

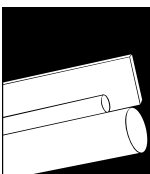

PRECISION DRILL ROD

W1 481 PRECISION GROUND AND POLISHED DRILL ROD

CONTINUED

| Fractional Sizes | | |
|------------------|---------|------------|
| Diameter | Decimal | 36" Length |
| 1/16 | 0.0625 | 68482 |
| 5/64 | 0.0781 | 68483 |
| 3/32 | 0.0938 | 68484 |
| 7/64 | 0.1094 | 68485 |
| 1/8 | 0.1250 | 68486 |
| 9/64 | 0.1406 | 68487 |
| 5/32 | 0.1563 | 68488 |
| 11/64 | 0.1719 | 68489 |
| 3/16 | 0.1875 | 68490 |
| 13/64 | 0.2031 | 68491 |
| 7/32 | 0.2188 | 68492 |
| 15/64 | 0.2344 | 68493 |
| 1/4 | 0.2500 | 68494 |
| 17/64 | 0.2656 | 68495 |
| 9/32 | 0.2813 | 68496 |
| 19/64 | 0.2969 | 68497 |
| 5/16 | 0.3125 | 68498 |
| 21/64 | 0.3281 | 68499 |
| 11/32 | 0.3438 | 68500 |
| 23/64 | 0.3594 | 68501 |
| 3/8 | 0.3750 | 68502 |
| 25/64 | 0.3906 | 68503 |
| 13/32 | 0.4063 | 68504 |
| 27/64 | 0.4219 | 68505 |
| 7/16 | 0.4375 | 68506 |
| 29/64 | 0.4531 | 68507 |
| 15/32 | 0.4688 | 68508 |
| 31/64 | 0.4844 | 68509 |
| 1/2 | 0.5000 | 68510 |
| 33/64 | 0.5156 | 68511 |
| 17/32 | 0.5313 | 68512 |
| 35/64 | 0.5469 | 68513 |
| 9/16 | 0.5625 | 68514 |
| 37/64 | 0.5781 | 68515 |
| 19/32 | 0.5938 | 68516 |
| 39/64 | 0.6094 | 68517 |
| 5/8 | 0.6250 | 68518 |
| 41/64 | 0.6406 | 68519 |
| 21/32 | 0.6563 | 68520 |
| 43/64 | 0.6719 | 68521 |
| 11/16 | 0.6875 | 68522 |
| 45/64 | 0.7031 | 68523 |
| 23/32 | 0.7188 | 68524 |
| 47/64 | 0.7344 | 68525 |
| 3/4 | 0.7500 | 68526 |
| 49/64 | 0.7656 | 68527 |
| 25/32 | 0.7813 | 68528 |
| 51/64 | 0.7969 | 68529 |
| 13/16 | 0.8125 | 68530 |
| 53/64 | 0.8281 | 68531 |

| Fractional Sizes | | |
|------------------|---------|------------|
| Diameter | Decimal | 36" Length |
| 27/32 | 0.8438 | 68532 |
| 55/64 | 0.8594 | 68533 |
| 7/8 | 0.8750 | 68534 |
| 57/64 | 0.8906 | 68535 |
| 29/32 | 0.9063 | 68536 |
| 59/64 | 0.9219 | 68537 |
| 15/16 | 0.9375 | 68538 |
| 61/64 | 0.9531 | 68539 |
| 31/32 | 0.9688 | 68540 |
| 63/64 | 0.9844 | 68541 |
| 1 | 1.0000 | 68542 |
| 1-1/64 | 1.0156 | 68543 |
| 1-1/32 | 1.0313 | 68544 |
| 1-3/64 | 1.0469 | 68545 |
| 1-1/16 | 1.0625 | 68546 |
| 1-5/64 | 1.0781 | 68547 |
| 1-3/32 | 1.0938 | 68548 |
| 1-7/64 | 1.1094 | 68549 |
| 1-1/8 | 1.1250 | 68550 |
| 1-9/64 | 1.1406 | 68551 |
| 1-5/32 | 1.1563 | 68552 |
| 1-11/64 | 1.1719 | 68553 |
| 1-3/16 | 1.1875 | 68554 |
| 1-13/64 | 1.2031 | 68555 |
| 1-15/64 | 1.2344 | 68557 |
| 1-1/4 | 1.2500 | 68558 |
| 1-17/64 | 1.2656 | 68559 |
| 1-9/32 | 1.2813 | 68560 |
| 1-19/64 | 1.2969 | 68561 |
| 1-5/16 | 1.3125 | 68562 |
| 1-21/64 | 1.3281 | 68563 |
| 1-11/32 | 1.3438 | 68564 |
| 1-23/64 | 1.3594 | 68565 |
| 1-3/8 | 1.3750 | 68566 |
| 1-25/64 | 1.3906 | 68567 |
| 1-13/32 | 1.4063 | 68568 |
| 1-27/64 | 1.4219 | 68569 |
| 1-7/16 | 1.4375 | 68570 |
| 1-29/64 | 1.4531 | 68571 |
| 1-15/32 | 1.4688 | 68572 |
| 1-31/64 | 1.4844 | 68573 |
| 1-1/2 | 1.5000 | 68574 |
| 1-9/16 | 1.5625 | 68575 |
| 1-5/8 | 1.6250 | 68576 |
| 1-11/16 | 1.6875 | 68577 |
| 1-3/4 | 1.7500 | 68578 |
| 1-13/16 | 1.8125 | 68579 |
| 1-7/8 | 1.8750 | 68580 |
| 1-15/16 | 1.9375 | 68581 |
| 2 | 2.0000 | 68582 |

Sizes other than listed priced on application

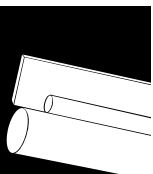



PRECISION DRILL ROD

A2 482 PRECISION GROUND AND POLISHED DRILL ROD

AISI/SAE A2 is a more highly alloyed tool steel that provides excellent wear resistance and toughness and good machinability.

NOMINAL ANALYSIS (AISI A2)

| | |
|------------------|------|
| Carbon | 1.00 |
| Chromium | 5.25 |
| Manganese | .60 |
| Molybdenum | 1.00 |
| Silicon | .40 |
| Vanadium | .25 |

Tolerances

| Size Range | Diameter | Length |
|----------------------|----------|------------|
| .124" round and less | ± .0003" | + 1/8" - 0 |
| .125" to .499" | ± .0005" | + 1/8" - 0 |
| .500" to 2" | ± .0010" | + 1/8" - 0 |

Heat Treatment and Tempering Data available upon request

FLAT STOCK AND DRILL ROD

A2 482 PRECISION GROUND AND POLISHED DRILL ROD

| Fractional Sizes | | |
|------------------|---------|------------|
| Diameter in | Decimal | 36" Length |
| 1/16 | 0.0625 | 68662 |
| 5/64 | 0.0781 | 68663 |
| 3/32 | 0.0938 | 68664 |
| 7/64 | 0.1094 | 68665 |
| 1/8 | 0.1250 | 68583 |
| 9/64 | 0.1406 | 68666 |
| 5/32 | 0.1563 | 68631 |
| 11/64 | 0.1719 | 68667 |
| 3/16 | 0.1875 | 68584 |
| 13/64 | 0.2031 | 68668 |
| 7/32 | 0.2188 | 68632 |
| 15/64 | 0.2344 | 68669 |
| 1/4 | 0.2500 | 68585 |
| 17/64 | 0.2656 | 68670 |
| 9/32 | 0.2813 | 68633 |
| 19/64 | 0.2969 | 68671 |
| 5/16 | 0.3125 | 68586 |
| 21/64 | 0.3281 | 68672 |
| 11/32 | 0.3438 | 68634 |
| 23/64 | 0.3594 | 68673 |
| 3/8 | 0.3750 | 68587 |
| 25/64 | 0.3906 | 68674 |
| 13/32 | 0.4063 | 68675 |
| 27/64 | 0.4219 | 68676 |

| Fractional Sizes | | |
|------------------|---------|------------|
| Diameter in | Decimal | 36" Length |
| 7/16 | 0.4375 | 68588 |
| 29/64 | 0.4531 | 68677 |
| 15/32 | 0.4688 | 68678 |
| 31/64 | 0.4844 | 68679 |
| 1/2 | 0.5000 | 68589 |
| 17/32 | 0.5313 | 68680 |
| 9/16 | 0.5625 | 68590 |
| 19/32 | 0.5938 | 68681 |
| 5/8 | 0.6250 | 68591 |
| 21/32 | 0.6563 | 68682 |
| 11/16 | 0.6875 | 68592 |
| 23/32 | 0.7188 | 68683 |
| 3/4 | 0.7500 | 68593 |
| 13/16 | 0.8125 | 68594 |
| 7/8 | 0.8750 | 68595 |
| 15/16 | 0.9375 | 68684 |
| 1 | 1.0000 | 68596 |
| 11/16 | 1.0625 | 68685 |
| 1-1/8 | 1.1250 | 68597 |
| 1-1/4 | 1.2500 | 68598 |
| 13/8 | 1.3750 | 68686 |
| 1-1/2 | 1.5000 | 68599 |
| 13/4 | 1.7500 | 68687 |
| 2 | 2.0000 | 68688 |

Sizes other than listed priced on application

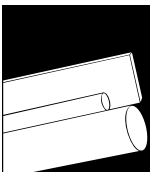



PRECISION MAKES THE DIFFERENCE

PURE PRECISION.

The combined powerful features of our metrology inspection and measurement systems will provide your test facility with a multi-functional measurement and inspection system that will serve you for years to come.



Starrett®

(978) 249-3551 • starrett.com

Follow us!





To order printed literature or view an electronic version of the publications in this section, please visit starrett.com/catalogs

VOCATIONAL AND EDUCATIONAL

FREE LITERATURE AVAILABLE AT STARRETT.COM

GETTING STARRETT LITERATURE JUST GOT EASIER

HOW TO ORDER

Ordering literature has never been easier. Visit our literature site at starrett.com/catalogs where our simple catalog ordering interface allows you to create an account, select printed material you would like to order and have it shipped directly to you at no cost.

Literature ranges from posters that can be hung in the workshop to booklets that help explain how to utilize your Starrett tools. Pocket cards and memo pads are also available for those who need precise measurements while on the job, or in the classroom.



ALSO AVAILABLE

User Manuals · Datasheets · Whitepapers · Material Safety Data Sheets (MSDS) · Starrett-3D Parts Catalog · Digital Design Assistant · Videos

HOW TO CREATE A LITERATURE ACCOUNT

1. Log onto starrett.com
2. Select "Catalogs"
3. Select "Create Account"
4. Fill in your mailing information and create a password
5. Select your User Group - New User, Educator, Distributor, or Sales
6. Select "Submit Registration" to create your account

Starrett Catalogs

| Cat. No. | Description |
|----------|-----------------------------|
| Cat. 33 | Precision Tool Catalog |
| Cat. 60 | Band Saw Blade Catalog |
| Cat. 71 | PTA and Hand Tool Catalog |
| Cat. 81 | Metrology Equipment Catalog |

Complete list of literature, visit starrett.com/catalogs

STARRETT LITERATURE AT YOUR FINGERTIPS

Our digital catalogs contain all of the information you have come to expect from our printed literature, but without taking up space on your desk.

FEATURES

- Access to all Starrett catalogs, brochures, datasheets and educational materials
- Easy sharing through email
- Print a page
- Quickly download the whole catalog for convenient offline viewing



Starrett
Precision, Quality, and Innovation... Since 1880

INCH/METRIC TAP DRILL SIZES & DECIMAL EQUIVALENTS

| DRILL SIZE | DECIMAL EQUIVALENT | TAP SIZE | DRILL SIZE | DECIMAL EQUIVALENT | TAP SIZE | DRILL SIZE | DECIMAL EQUIVALENT | TAP SIZE |
|------------|--------------------|------------|------------|--------------------|-----------|------------|--------------------|------------|
| 80 | .0135 | | 10 | .1935 | | 50 | .9219 | 1 - 12 |
| 79 | .0145 | | 9 | .1960 | | 51 | .9375 | 1 - 14 |
| 78 | .0160 | | 8 | .2010 | | 52 | .9531 | 1 - 16 |
| 77 | .0180 | | 7 | .2031 | 1/4 - 20 | 53 | .9688 | 1 1/8 - 7 |
| 76 | .0200 | | 6 | .2045 | | 54 | .9844 | 1 1/8 - 7 |
| 75 | .0210 | | 5 | .2055 | | 55 | 1.0000 | 1 1/8 - 12 |
| 74 | .0225 | | 4 | .2090 | | 56 | 1.0156 | 1 1/8 - 7 |
| 73 | .0240 | | 3 | .2130 | 1/4 - 28 | 57 | 1.0313 | 1 1/8 - 12 |
| 72 | .0250 | | 2 | .2188 | | 58 | 1.0469 | 1 1/8 - 6 |
| 71 | .0260 | | 1 | .2210 | | 59 | 1.0625 | 1 1/8 - 12 |
| 70 | .0280 | | A | .2280 | | 60 | 1.0781 | 1 1/8 - 6 |
| 69 | .0292 | | B | .2340 | | 61 | 1.0938 | 1 1/2 - 12 |
| 68 | .0310 | | C | .2380 | | 62 | 1.1094 | 1 1/2 - 12 |
| 67 | .0320 | | D | .2420 | | 63 | 1.1250 | |
| 66 | .0330 | | E | .2460 | | 64 | 1.1406 | |
| 65 | .0350 | | F | .2500 | 1/8 - 18 | | | |
| 64 | .0360 | | G | .2570 | | | | |
| 63 | .0370 | | H | .2610 | | | | |
| 62 | .0380 | | I | .2656 | | | | |
| 61 | .0390 | | J | .2660 | | | | |
| 60 | .0400 | | K | .2720 | 1/8 - 24 | | | |
| 59 | .0410 | | L | .2770 | | | | |
| 58 | .0420 | | M | .2810 | | | | |
| 57 | .0430 | | N | .2812 | | | | |
| 56 | .0445 | | O | .2850 | 3/8 - 16 | | | |
| 55 | .0460 | 0 - 80 | P | .2850 | | | | |
| 54 | .0460 | | Q | .2899 | | | | |
| 53 | .0485 | 1 - 64, 72 | R | .2920 | | | | |
| 52 | .0500 | | S | .2950 | | | | |
| 51 | .0510 | | T | .2989 | | | | |
| 50 | .0520 | 2 - 56, 64 | U | .3020 | | | | |
| 49 | .0530 | | V | .3060 | | | | |
| 48 | .0545 | | W | .3090 | 7/16 - 14 | | | |
| 47 | .0560 | | X | .3125 | | | | |
| 46 | .0575 | 3 - 48 | Y | .3160 | | | | |
| 45 | .0590 | | Z | .3200 | | | | |
| 44 | .0600 | | | .3220 | 3/8 - 24 | | | |
| 43 | .0610 | | | .3230 | | | | |
| 42 | .0625 | 4 - 40 | | .3290 | | | | |
| 41 | .0640 | | | .3320 | | | | |
| 40 | .0650 | 4 - 48 | | .3390 | | | | |
| 39 | .0660 | | | .3438 | | | | |
| 38 | .0675 | | | .3480 | | | | |
| 37 | .0690 | | | .3580 | | | | |
| 36 | .0700 | 5 - 40 | | .3580 | | | | |
| 35 | .0710 | | | .3594 | 7/16 - 14 | | | |
| 34 | .0725 | | | .3660 | | | | |
| 33 | .0740 | 6 - 32 | | .3750 | | | | |
| 32 | .0750 | | | .3770 | 7/16 - 20 | | | |
| 31 | .0760 | | | .3806 | | | | |
| 30 | .0775 | | | .3870 | | | | |
| 29 | .0790 | | | .4040 | | | | |
| 28 | .0810 | 5 - 44 | | .4062 | | | | |
| 27 | .0820 | | | .4130 | | | | |
| 26 | .0830 | 6 - 32 | | .4219 | 1/2 - 13 | | | |
| 25 | .0840 | | | .4290 | | | | |
| 24 | .0850 | | | .4310 | | | | |
| 23 | .0860 | | | .4375 | 1/2 - 20 | | | |
| 22 | .0875 | | | .4431 | | | | |
| 21 | .0890 | | | .4494 | 9/16 - 12 | | | |
| 20 | .0900 | 6 - 40 | | .4544 | | | | |
| 19 | .0910 | | | .4594 | | | | |
| 18 | .0920 | | | .4644 | 9/16 - 18 | | | |
| 17 | .0930 | | | .4694 | | | | |
| 16 | .0940 | | | .4744 | 9/16 - 11 | | | |
| 15 | .0950 | | | .4794 | | | | |
| 14 | .0960 | 8 - 32, 36 | | .4844 | | | | |
| 13 | .0970 | | | .4894 | | | | |
| 12 | .0980 | | | .4944 | 1/2 - 18 | | | |
| 11 | .0990 | | | .4994 | | | | |
| 10 | .1000 | | | .5044 | 1/2 - 16 | | | |
| 9 | .1010 | | | .5094 | | | | |
| 8 | .1020 | | | .5144 | | | | |
| 7 | .1030 | | | .5194 | | | | |
| 6 | .1040 | | | .5244 | | | | |
| 5 | .1050 | | | .5294 | | | | |
| 4 | .1060 | | | .5344 | | | | |
| 3 | .1070 | | | .5394 | | | | |
| 2 | .1080 | | | .5444 | | | | |
| 1 | .1090 | | | .5494 | | | | |
| | .1100 | | | .5544 | | | | |
| | .1110 | | | .5594 | | | | |
| | .1120 | | | .5644 | | | | |
| | .1130 | | | .5694 | | | | |
| | .1140 | | | .5744 | | | | |
| | .1150 | | | .5794 | | | | |
| | .1160 | | | .5844 | | | | |
| | .1170 | | | .5894 | | | | |
| | .1180 | | | .5944 | | | | |
| | .1190 | | | .5994 | | | | |
| | .1200 | | | .6044 | | | | |
| | .1210 | | | .6094 | | | | |
| | .1220 | | | .6144 | | | | |
| | .1230 | | | .6194 | | | | |
| | .1240 | | | .6244 | | | | |
| | .1250 | | | .6294 | | | | |
| | .1260 | | | .6344 | | | | |
| | .1270 | | | .6394 | | | | |
| | .1280 | | | .6444 | | | | |
| | .1290 | | | .6494 | | | | |
| | .1300 | | | .6544 | | | | |
| | .1310 | | | .6594 | | | | |
| | .1320 | | | .6644 | | | | |
| | .1330 | | | .6694 | | | | |
| | .1340 | | | .6744 | | | | |
| | .1350 | | | .6794 | | | | |
| | .1360 | | | .6844 | | | | |
| | .1370 | | | .6894 | | | | |
| | .1380 | | | .6944 | | | | |
| | .1390 | | | .6994 | | | | |
| | .1400 | | | .7044 | | | | |
| | .1410 | | | .7094 | | | | |
| | .1420 | | | .7144 | | | | |
| | .1430 | | | .7194 | | | | |
| | .1440 | | | .7244 | | | | |
| | .1450 | | | .7294 | | | | |
| | .1460 | | | .7344 | | | | |
| | .1470 | | | .7394 | | | | |
| | .1480 | | | .7444 | | | | |
| | .1490 | | | .7494 | | | | |
| | .1500 | | | .7544 | | | | |
| | .1510 | | | .7594 | | | | |
| | .1520 | | | .7644 | | | | |
| | .1530 | | | .7694 | | | | |
| | .1540 | | | .7744 | | | | |
| | .1550 | | | .7794 | | | | |
| | .1560 | | | .7844 | | | | |
| | .1570 | | | .7894 | | | | |
| | .1580 | | | .7944 | | | | |
| | .1590 | | | .7994 | | | | |
| | .1600 | | | .8044 | | | | |
| | .1610 | | | .8094 | | | | |
| | .1620 | | | .8144 | | | | |
| | .1630 | | | .8194 | | | | |
| | .1640 | | | .8244 | | | | |
| | .1650 | | | .8294 | | | | |
| | .1660 | | | .8344 | | | | |
| | .1670 | | | .8394 | | | | |
| | .1680 | | | .8444 | | | | |
| | .1690 | | | .8494 | | | | |
| | .1700 | | | .8544 | | | | |
| | .1710 | | | .8594 | | | | |
| | .1720 | | | .8644 | | | | |
| | .1730 | | | .8694 | | | | |
| | .1740 | | | .8744 | | | | |
| | .1750 | | | .8794 | | | | |
| | .1760 | | | .8844 | | | | |
| | .1770 | | | .8894 | | | | |
| | .1780 | | | .8944 | | | | |
| | .1790 | | | .8994 | | | | |
| | .1800 | | | .9044 | | | | |
| | .1810 | | | .9094 | | | | |
| | .1820 | | | .9144 | | | | |
| | .1830 | | | .9194 | | | | |
| | .1840 | | | .9244 | | | | |
| | .1850 | | | .9294 | | | | |
| | .1860 | | | .9344 | | | | |
| | .1870 | | | .9394 | | | | |
| | .1880 | | | .9444 | | | | |
| | .1890 | | | .9494 | | | | |
| | .1900 | | | .9544 | | | | |
| | .1910 | | | .9594 | | | | |

METRIC TAP DRILL SIZES

| METRIC TAP | TAP DRILL SIZE | METRIC TAP | TAP DRILL SIZE |
|-------------|----------------|------------|----------------|
| M1.6 x 0.35 | 1.28 | 0.452 | |
| M1.8 x 0.35 | 1.45 | .0571 | |
| M2 x 0.4 | 1.60 | .0630 | |
| M2.2 x 0.45 | 1.75 | .0689 | |
| M2.5 x 0.45 | 2.05 | .0807 | |
| M3 x 0.5 | 2.50 | .0994 | |
| M3.5 x 0.6 | 2.90 | .1142 | |
| M4 x 0.7 | 3.30 | .1299 | |
| M4.5 x 0.75 | 3.70 | .1457 | |
| M5 x 0.8 | 4.20 | .1654 | |
| M6 x 1 | 5.00 | .1968 | |
| M7 x 1 | 6.00 | .2362 | |
| M8 x 1.25 | 6.70 | .2638 | |
| M8 x 1 | 7.00 | .2756 | |
| M10 x 1.5 | 8.50 | .3346 | |
| M10 x 1.25 | 8.70 | .3425 | |
| M12 x 1.75 | 10.20 | .4016 | |
| M12 x 1.25 | 10.80 | .4252 | |
| M14 x 2 | 12.00 | .4724 | |
| M14 x 1.5 | 12.50 | .4921 | |
| M16 x 2 | 14.00 | .5512 | |
| M16 x 1.5 | 14.50 | .5709 | |
| M18 x 2.5 | 15.50 | .6102 | |
| M18 x 1.5 | 16.50 | .6496 | |
| M20 x 2.5 | 17.50 | .6890 | |
| M20 x 1.5 | 18.50 | | |

FREE LITERATURE
AVAILABLE AT STARRETT.COM

TOOLS AND RULES FOR PRECISION MEASURING

This valuable and popular training aid includes coverage of newer tools as well as the familiar reference material to traditional topics. This booklet tells the story of precision measurements in down-to-earth language that has been popular over the years.

Information includes: linear measuring standards; measuring and transferring measurements; steel rules; calipers and dividers; how to read vernier tools and the micrometer; types of micrometers; gage blocks and digital measuring tools; dial indicators; layout with accuracy; measuring lathe work; measuring screw threads; facts about fit; limits of tolerance; electronic tools; and also includes a helpful reference section – decimal equivalents, squares, cubes, square and cube roots, tap drill and screw thread information.

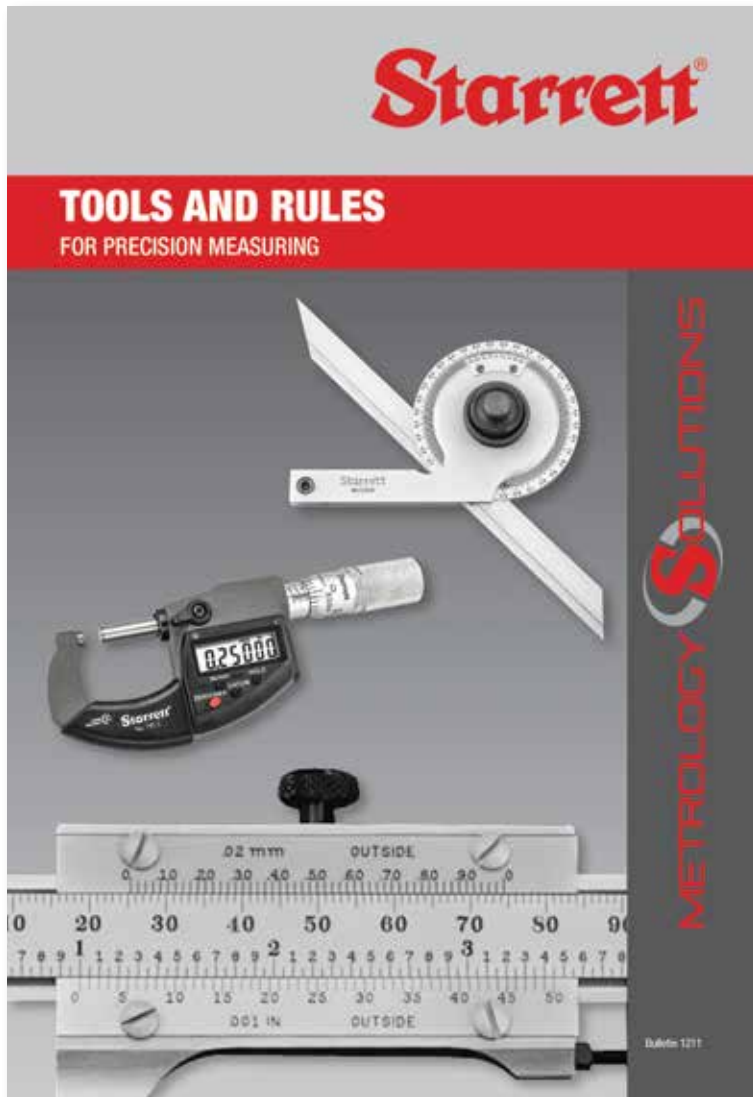

| Cat. No. | Description |
|----------|-----------------|
| 1211 | Tools and Rules |

Complete list of literature, visit starrett.com/catalogs

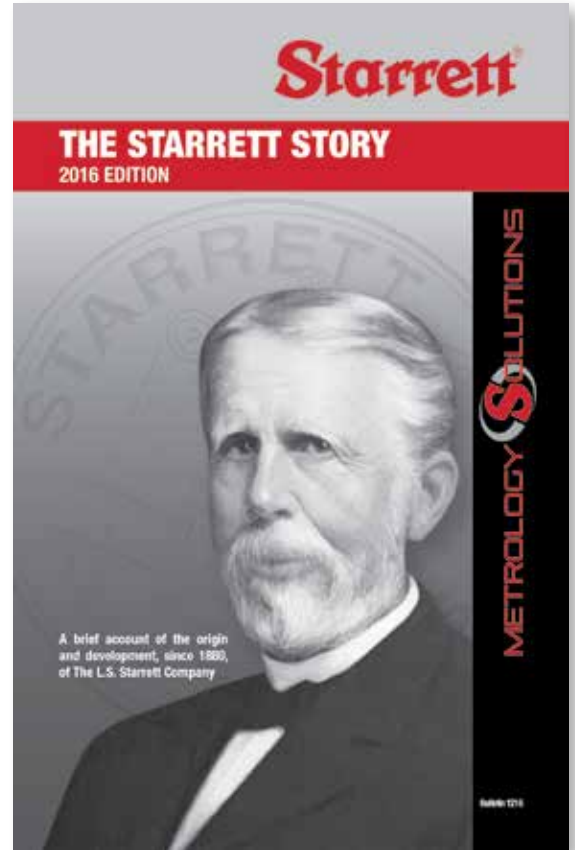

THE STARRETT STORY

A brief history of The L.S. Starrett Company, which was founded over 133 years ago by an early mechanical genius, Laroy S. Starrett. It reviews the founder's boyhood years, business problems and successes, tools introduced, personal philosophy and community service. A fascinating story of ambition, perseverance, accomplishment and contribution to industry and his fellow man.

| Cat. No. | Description |
|----------|--------------------|
| 1216 | The Starrett Story |

Complete list of literature, visit starrett.com/catalogs





FREE LITERATURE
AVAILABLE AT STARRETT.COM

| Starrett | | DECIMAL EQUIVALENTS | |
|---|-----------|---------------------|------------|
| INCH/METRIC TAP DRILL SIZES & DECIMAL EQUIVALENTS | | | |
| DRILL SIZE | TAP SIZE | DECIMAL EQUIVALENT | DRILL SIZE |
| #0 | M2 x 0.25 | 1.29 | .0482 |
| #1 | M2 x 0.30 | 1.45 | .0571 |
| #2 | M2 x 0.4 | 1.62 | .0635 |
| #3 | M2 x 0.48 | 1.78 | .0699 |
| #4 | M2 x 0.5 | 1.88 | .0743 |
| #5 | M2 x 0.55 | 2.05 | .0807 |
| #6 | M2 x 0.6 | 2.21 | .0871 |
| #7 | M2 x 0.7 | 2.37 | .0935 |
| #8 | M2 x 0.8 | 2.54 | .1000 |
| #9 | M2 x 0.9 | 2.70 | .1064 |
| #10 | M2 x 1.0 | 2.87 | .1129 |
| #11 | M2 x 1.1 | 3.03 | .1193 |
| #12 | M2 x 1.2 | 3.20 | .1258 |
| #14 | M2 x 1.4 | 3.54 | .1393 |
| #16 | M2 x 1.6 | 3.90 | .1528 |
| #18 | M2 x 1.8 | 4.26 | .1663 |
| #20 | M2 x 2.0 | 4.75 | .1871 |
| #22 | M2 x 2.2 | 5.24 | .2079 |
| #24 | M2 x 2.4 | 5.73 | .2287 |
| #27 | M2 x 2.7 | 6.61 | .2603 |
| #30 | M2 x 3.0 | 7.50 | .2919 |
| #33 | M2 x 3.3 | 8.38 | .3235 |
| #36 | M2 x 3.6 | 9.26 | .3551 |
| #39 | M2 x 3.9 | 10.15 | .3867 |
| #42 | M2 x 4.2 | 11.03 | .4183 |
| #45 | M2 x 4.5 | 11.92 | .4499 |
| #48 | M2 x 4.8 | 12.80 | .4815 |
| #51 | M2 x 5.1 | 13.69 | .5131 |
| #54 | M2 x 5.4 | 14.57 | .5447 |
| #57 | M2 x 5.7 | 15.46 | .5763 |
| #60 | M2 x 6.0 | 16.34 | .6079 |
| #63 | M2 x 6.3 | 17.23 | .6395 |
| #66 | M2 x 6.6 | 18.11 | .6711 |
| #69 | M2 x 6.9 | 19.00 | .7027 |
| #72 | M2 x 7.2 | 19.88 | .7343 |
| #75 | M2 x 7.5 | 20.77 | .7659 |
| #78 | M2 x 7.8 | 21.65 | .7975 |
| #81 | M2 x 8.1 | 22.54 | .8291 |
| #84 | M2 x 8.4 | 23.42 | .8607 |
| #87 | M2 x 8.7 | 24.31 | .8923 |
| #90 | M2 x 9.0 | 25.19 | .9239 |
| #93 | M2 x 9.3 | 26.08 | .9555 |
| #96 | M2 x 9.6 | 26.96 | .9871 |
| #99 | M2 x 9.9 | 27.85 | 1.0187 |
| #102 | M2 x 10.2 | 28.73 | 1.0503 |
| #105 | M2 x 10.5 | 29.62 | 1.0819 |
| #108 | M2 x 10.8 | 30.50 | 1.1135 |
| #111 | M2 x 11.1 | 31.39 | 1.1451 |
| #114 | M2 x 11.4 | 32.27 | 1.1767 |
| #117 | M2 x 11.7 | 33.16 | 1.2083 |
| #120 | M2 x 12.0 | 34.04 | 1.2399 |
| #123 | M2 x 12.3 | 34.93 | 1.2715 |
| #126 | M2 x 12.6 | 35.81 | 1.3031 |
| #129 | M2 x 12.9 | 36.70 | 1.3347 |
| #132 | M2 x 13.2 | 37.58 | 1.3663 |
| #135 | M2 x 13.5 | 38.47 | 1.3979 |
| #138 | M2 x 13.8 | 39.35 | 1.4295 |
| #141 | M2 x 14.1 | 40.24 | 1.4611 |
| #144 | M2 x 14.4 | 41.12 | 1.4927 |
| #147 | M2 x 14.7 | 42.01 | 1.5243 |
| #150 | M2 x 15.0 | 42.89 | 1.5559 |
| #153 | M2 x 15.3 | 43.78 | 1.5875 |
| #156 | M2 x 15.6 | 44.66 | 1.6191 |
| #159 | M2 x 15.9 | 45.55 | 1.6507 |
| #162 | M2 x 16.2 | 46.43 | 1.6823 |
| #165 | M2 x 16.5 | 47.32 | 1.7139 |
| #168 | M2 x 16.8 | 48.20 | 1.7455 |
| #171 | M2 x 17.1 | 49.09 | 1.7771 |
| #174 | M2 x 17.4 | 49.97 | 1.8087 |
| #177 | M2 x 17.7 | 50.86 | 1.8403 |
| #180 | M2 x 18.0 | 51.74 | 1.8719 |
| #183 | M2 x 18.3 | 52.63 | 1.9035 |
| #186 | M2 x 18.6 | 53.51 | 1.9351 |
| #189 | M2 x 18.9 | 54.40 | 1.9667 |
| #192 | M2 x 19.2 | 55.28 | 1.9983 |
| #195 | M2 x 19.5 | 56.17 | 2.0299 |
| #198 | M2 x 19.8 | 57.05 | 2.0615 |
| #201 | M2 x 20.1 | 57.94 | 2.0931 |
| #204 | M2 x 20.4 | 58.82 | 2.1247 |
| #207 | M2 x 20.7 | 59.71 | 2.1563 |
| #210 | M2 x 21.0 | 60.59 | 2.1879 |
| #213 | M2 x 21.3 | 61.48 | 2.2195 |
| #216 | M2 x 21.6 | 62.36 | 2.2511 |
| #219 | M2 x 21.9 | 63.25 | 2.2827 |
| #222 | M2 x 22.2 | 64.13 | 2.3143 |
| #225 | M2 x 22.5 | 65.02 | 2.3459 |
| #228 | M2 x 22.8 | 65.90 | 2.3775 |
| #231 | M2 x 23.1 | 66.79 | 2.4091 |
| #234 | M2 x 23.4 | 67.67 | 2.4407 |
| #237 | M2 x 23.7 | 68.56 | 2.4723 |
| #240 | M2 x 24.0 | 69.44 | 2.5039 |
| #243 | M2 x 24.3 | 70.33 | 2.5355 |
| #246 | M2 x 24.6 | 71.21 | 2.5671 |
| #249 | M2 x 24.9 | 72.10 | 2.5987 |
| #252 | M2 x 25.2 | 72.98 | 2.6303 |
| #255 | M2 x 25.5 | 73.87 | 2.6619 |
| #258 | M2 x 25.8 | 74.75 | 2.6935 |
| #261 | M2 x 26.1 | 75.64 | 2.7251 |
| #264 | M2 x 26.4 | 76.52 | 2.7567 |
| #267 | M2 x 26.7 | 77.41 | 2.7883 |
| #270 | M2 x 27.0 | 78.29 | 2.8199 |
| #273 | M2 x 27.3 | 79.18 | 2.8515 |
| #276 | M2 x 27.6 | 80.06 | 2.8831 |
| #279 | M2 x 27.9 | 80.95 | 2.9147 |
| #282 | M2 x 28.2 | 81.83 | 2.9463 |
| #285 | M2 x 28.5 | 82.72 | 2.9779 |
| #288 | M2 x 28.8 | 83.60 | 3.0095 |
| #291 | M2 x 29.1 | 84.49 | 3.0411 |
| #294 | M2 x 29.4 | 85.37 | 3.0727 |
| #297 | M2 x 29.7 | 86.26 | 3.1043 |
| #300 | M2 x 30.0 | 87.14 | 3.1359 |
| #303 | M2 x 30.3 | 88.03 | 3.1675 |
| #306 | M2 x 30.6 | 88.91 | 3.1991 |
| #309 | M2 x 30.9 | 89.80 | 3.2307 |
| #312 | M2 x 31.2 | 90.68 | 3.2623 |
| #315 | M2 x 31.5 | 91.57 | 3.2939 |
| #318 | M2 x 31.8 | 92.45 | 3.3255 |
| #321 | M2 x 32.1 | 93.34 | 3.3571 |
| #324 | M2 x 32.4 | 94.22 | 3.3887 |
| #327 | M2 x 32.7 | 95.11 | 3.4203 |
| #330 | M2 x 33.0 | 96.00 | 3.4519 |
| #333 | M2 x 33.3 | 96.88 | 3.4835 |
| #336 | M2 x 33.6 | 97.77 | 3.5151 |
| #339 | M2 x 33.9 | 98.65 | 3.5467 |
| #342 | M2 x 34.2 | 99.54 | 3.5783 |
| #345 | M2 x 34.5 | 100.42 | 3.6099 |
| #348 | M2 x 34.8 | 101.31 | 3.6415 |
| #351 | M2 x 35.1 | 102.19 | 3.6731 |
| #354 | M2 x 35.4 | 103.08 | 3.7047 |
| #357 | M2 x 35.7 | 103.96 | 3.7363 |
| #360 | M2 x 36.0 | 104.85 | 3.7679 |
| #363 | M2 x 36.3 | 105.73 | 3.7995 |
| #366 | M2 x 36.6 | 106.62 | 3.8311 |
| #369 | M2 x 36.9 | 107.50 | 3.8627 |
| #372 | M2 x 37.2 | 108.39 | 3.8943 |
| #375 | M2 x 37.5 | 109.27 | 3.9259 |
| #378 | M2 x 37.8 | 110.16 | 3.9575 |
| #381 | M2 x 38.1 | 111.04 | 3.9891 |
| #384 | M2 x 38.4 | 111.93 | 4.0207 |
| #387 | M2 x 38.7 | 112.81 | 4.0523 |
| #390 | M2 x 39.0 | 113.70 | 4.0839 |
| #393 | M2 x 39.3 | 114.58 | 4.1155 |
| #396 | M2 x 39.6 | 115.47 | 4.1471 |
| #399 | M2 x 39.9 | 116.35 | 4.1787 |
| #402 | M2 x 40.2 | 117.24 | 4.2103 |
| #405 | M2 x 40.5 | 118.12 | 4.2419 |
| #408 | M2 x 40.8 | 119.01 | 4.2735 |
| #411 | M2 x 41.1 | 119.89 | 4.3051 |
| #414 | M2 x 41.4 | 120.78 | 4.3367 |
| #417 | M2 x 41.7 | 121.66 | 4.3683 |
| #420 | M2 x 42.0 | 122.55 | 4.4000 |
| #423 | M2 x 42.3 | 123.43 | 4.4316 |
| #426 | M2 x 42.6 | 124.32 | 4.4632 |
| #429 | M2 x 42.9 | 125.20 | 4.4948 |
| #432 | M2 x 43.2 | 126.09 | 4.5264 |
| #435 | M2 x 43.5 | 126.97 | 4.5580 |
| #438 | M2 x 43.8 | 127.86 | 4.5896 |
| #441 | M2 x 44.1 | 128.74 | 4.6212 |
| #444 | M2 x 44.4 | 129.63 | 4.6528 |
| #447 | M2 x 44.7 | 130.51 | 4.6844 |
| #450 | M2 x 45.0 | 131.40 | 4.7160 |
| #453 | M2 x 45.3 | 132.28 | 4.7476 |
| #456 | M2 x 45.6 | 133.17 | 4.7792 |
| #459 | M2 x 45.9 | 134.05 | 4.8108 |
| #462 | M2 x 46.2 | 134.94 | 4.8424 |
| #465 | M2 x 46.5 | 135.82 | 4.8740 |
| #468 | M2 x 46.8 | 136.71 | 4.9056 |
| #471 | M2 x 47.1 | 137.59 | 4.9372 |
| #474 | M2 x 47.4 | 138.48 | 4.9688 |
| #477 | M2 x 47.7 | 139.36 | 5.0004 |
| #480 | M2 x 48.0 | 140.25 | 5.0320 |
| #483 | M2 x 48.3 | 141.13 | 5.0636 |
| #486 | M2 x 48.6 | 142.02 | 5.0952 |
| #489 | M2 x 48.9 | 142.90 | 5.1268 |
| #492 | M2 x 49.2 | 143.79 | 5.1584 |
| #495 | M2 x 49.5 | 144.67 | 5.1900 |
| #498 | M2 x 49.8 | 145.56 | 5.2216 |
| #501 | M2 x 50.1 | 146.44 | 5.2532 |
| #504 | M2 x 50.4 | 147.33 | 5.2848 |
| #507 | M2 x 50.7 | 148.21 | 5.3164 |
| #510 | M2 x 51.0 | 149.10 | 5.3480 |
| #513 | M2 x 51.3 | 150.00 | 5.3796 |
| #516 | M2 x 51.6 | 150.88 | 5.4112 |
| #519 | M2 x 51.9 | 151.77 | 5.4428 |
| #522 | M2 x 52.2 | 152.65 | 5.4744 |
| #525 | M2 x 52.5 | 153.54 | 5.5060 |
| #528 | M2 x 52.8 | 154.42 | 5.5376 |
| #531 | M2 x 53.1 | 155.31 | 5.5692 |
| #534 | M2 x 53.4 | 156.20 | 5.6008 |
| #537 | M2 x 53.7 | 157.08 | 5.6324 |
| #540 | M2 x 54.0 | 157.97 | 5.6640 |
| #543 | M2 x 54.3 | 158.85 | 5.6956 |
| #546 | M2 x 54.6 | 159.74 | 5.7272 |
| #549 | M2 x 54.9 | 160.62 | 5.7588 |
| #552 | M2 x 55.2 | 161.51 | 5.7904 |
| #555 | M2 x 55.5 | 162.40 | 5.8220 |
| #558 | M2 x 55.8 | 163.28 | 5.8536 |
| #561 | M2 x 56.1 | 164.17 | 5.8852 |
| #564 | M2 x 56.4 | 165.05 | 5.9168 |
| #567 | M2 x 56.7 | 165.94 | 5.9484 |
| #570 | M2 x 57.0 | 166.82 | 5.9800 |
| #573 | M2 x 57.3 | 167.71 | 6.0116 |
| #576 | M2 x 57.6 | 168.60 | 6.0432 |
| #579 | M2 x 57.9 | 169.48 | 6.0748 |
| #582 | M2 x 58.2 | 170.37 | 6.1064 |
| #585 | M2 x 58.5 | 171.25 | 6.1380 |
| #588 | M2 x 58.8 | 172.14 | 6.1696 |
| #591 | M2 x 59.1 | 173.02 | 6.2012 |
| #594 | M2 x 59.4 | 173.91 | 6.2328 |
| #597 | M2 x 59.7 | 174.79 | 6.2644 |
| #600 | M2 x 60.0 | 175.68 | 6.2960 |
| #603 | M2 x 60.3 | 176.56 | 6.3276 |
| #606 | M2 x 60.6 | 177.45 | 6.3592 |
| #609 | M2 x 60.9 | 178.33 | 6.3908 |
| #612 | M2 x 61.2 | 179.22 | 6.4224 |
| #615 | M2 x 61.5 | 180.10 | 6.4540 |
| #618 | M2 x 61.8 | 180.99 | 6.4856 |
| #621 | M2 x 62.1 | 181.87 | 6.5172 |
| #624 | M2 x 62.4 | 182.76 | 6.5488 |
| #627 | M2 x 62.7 | 183.64 | 6.5804 |
| #630 | M2 x 63.0 | 184.53 | 6.6120 |
| #633 | M2 x 63.3 | 185.41 | 6.6436 |
| #636 | M2 x 63.6 | 186.30 | 6.6752 |
| #639 | M2 x 63.9 | 187.18 | 6.7068 |
| #642 | M2 x 64.2 | 188.07 | 6.7384 |
| #645 | M2 x 64.5 | 188.95 | 6.7700 |
| #648 | M2 x 64.8 | 189.84 | 6.8016 |
| #651 | M2 x 65.1 | 190.72 | 6.8332 |
| #654 | M2 x 65.4 | 191.61 | 6.8648 |
| #657 | M2 x 65.7 | 192.49 | 6.8964 |
| #660 | M2 x 66.0 | 193.38 | 6.9280 |
| #663 | M2 x 66.3 | 194.26 | 6.9596 |
| #666 | M2 x 66.6 | 195.15 | 6.9912 |
| #669 | M2 x 66.9 | 196.03 | 7.0228 |
| #672 | M2 x 67.2 | 196.92 | 7.0544 |
| #675 | M2 x 67.5 | 197.80 | 7.0860 |
| #678 | M2 x 67.8 | 198.69 | 7.1176 |
| #681 | M2 x 68.1 | 199.57 | 7.1492 |
| #684 | M2 x 68.4 | 200.46 | 7.1808 |
| #687 | M2 x 68.7 | 201.34 | 7.2124 |
| #690 | M2 x 69.0 | 202.23 | 7.2440 |
| #693 | M2 x 69.3 | 203.11 | 7.2756 |
| #696 | M2 x 69.6 | 204.00 | 7.3072 |
| #699 | M2 x 69.9 | 204.88 | 7.3388 |
| #702 | M2 x 70.2 | 205.77 | 7.3704 |
| #705 | M2 x 70.5 | 206.65 | 7.4020 |
| #708 | M2 x 70.8 | 207.54 | 7.4336 |
| #711 | M2 x 71.1 | 208.42 | 7.4652 |
| #714 | M2 x 71.4 | 209.31 | 7.4968 |
| #717 | M2 x 71.7 | 210.19 | 7.5284 |
| #720 | M2 x 72.0 | 211.08 | 7.5600 |
| #723 | M2 x 72.3 | 211.96 | 7.5916 |
| #726 | M2 x 72.6 | 212.85 | 7.6232 |
| #729 | M2 x 72.9 | 213.73 | 7.6548 |
| #732 | M2 x 73.2 | 214.62 | 7.6864 |
| #735 | M2 x 73.5 | 215.50 | 7.7180 |
| #738 | M2 x 73.8 | 216.39 | 7.7496 |
| #741 | M2 x 74.1 | 217.27 | 7.7812 |
| #744 | M2 x 74.4 | 218.16 | 7.8128 |
| #747 | M2 x 74.7 | 219.04 | 7.8444 |
| #750 | M2 x 75.0 | 219.93 | 7.8760 |
| #753 | M2 x 75.3 | 220.81 | 7.9076 |
| #756 | M2 x 75.6 | 221.70 | 7.9392 |
| #759 | M2 x 75.9 | 222.58 | |

PRICED LITERATURE

THE STARRETT BOOK FOR STUDENT MACHINISTS

This familiar handbook for machine shop beginners is written in clear, simple language, contains 160 pages including 200 diagrams, illustrations, reference tables, and is fully indexed. Printed on coated paper with soil-resistant binding for durable machine shop use.

Chapter Headings: Mechanical Drawings; Fits and Terminology; Bench Work; How to Make Measurements; Cutting Speed and Cutting Fluids; Drilling and Related Operations; Lathe Operations; Grinding; Metal Sawing; Toolmaking; Geometry; Mechanics.

| | | |
|------|-------|--|
| 1700 | 53218 | The Starrett Book for Student Machinists |
|------|-------|--|

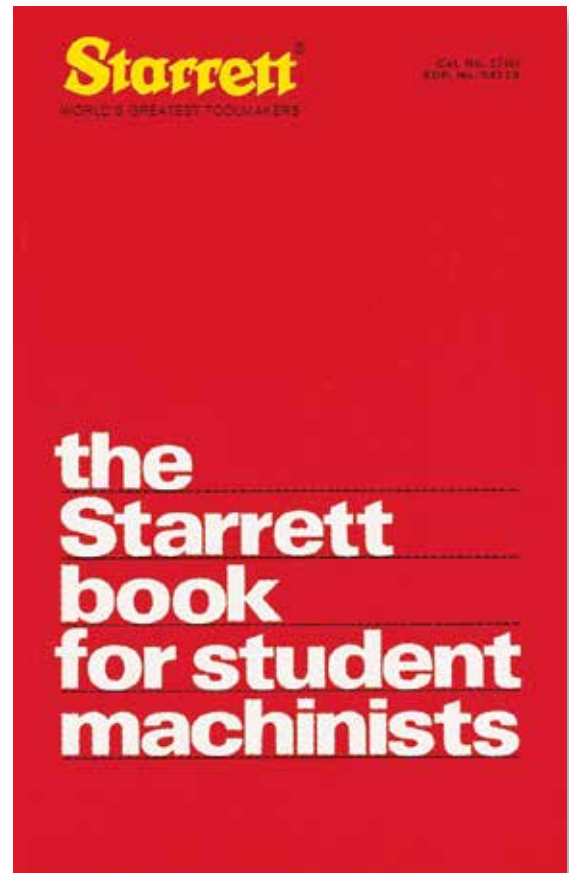

SET OF 17 EDUCATIONAL CHARTS

WALL SIZE | THREE-RING NOTEBOOK SIZE

Seventeen white print charts help learners recognize basic tools, their principal parts and uses. Tools illustrated: outside and inside micrometers; micrometer depth gage; vernier caliper and height gage; electronic micrometer and caliper; hook rule; combination square and bevel protractor; dial indicator and dial test indicators; dial caliper; magnetic base indicator holders; surface gage.

The set includes sheets on "How to Read Metric Measuring Tools" and "How to Read English Measuring Tools."

Wall size charts are 18-5/8 x 14-5/8" (473 x 371mm). Notebook size is 3-hole punched and 11 x 8-1/2" (280 x 216mm).

| Cat. No. | EDP | Description |
|----------|-------|---|
| 1702 | 56172 | Wall Size Educational Charts |
| 1715 | 53220 | Three-Ring Notebook Size Educational Charts |

HOW TO ORDER PRICED LITERATURE

To order priced literature please contact Customer Service at (978) 249-3551 extension 400.





Starrett®

Precision, Quality and Innovation...
Since 1880

INCH/METRIC TAP DRILL SIZES & DECIMAL EQUIVALENTS

| INCH/METRIC TAP DRILL SIZES & DECIMAL EQUIVALENTS | | DECIMAL EQUIVALENTS | | TAP SIZE | | DECIMAL EQUIVALENT | | TAP SIZE | |
|---|--------------------|---------------------|------------|--------------------|-----------|--------------------|--------------------|------------|--------------------|
| DRILL SIZE | DECIMAL EQUIVALENT | TAP SIZE | DRILL SIZE | DECIMAL EQUIVALENT | TAP SIZE | DRILL SIZE | DECIMAL EQUIVALENT | TAP SIZE | DECIMAL EQUIVALENT |
| 1 | .0135 | | 10 | .1935 | | 59 | .9219 | 1 - 12 | |
| 1 | .0145 | | 9 | .1960 | | 64 | .9375 | 1 - 14 | |
| 1 | .0156 | | 8 | .1990 | | 61 | .9531 | | |
| 1 | .0160 | | 7 | .2010 | 1/4 - 20 | 64 | .9688 | | |
| 1 | .0200 | | 6 | .2031 | | 63 | .9844 | 1 1/8 - 7 | |
| 1 | .0210 | | 5 | .2040 | | 64 | 1.0000 | 1 1/8 - 12 | |
| 1 | .0225 | | 4 | .2055 | | 1 3/64 | 1.0469 | 1 1/4 - 7 | |
| 1 | .0240 | | 3 | .2090 | 1/4 - 28 | 1 7/64 | 1.1094 | | |
| 1 | .0250 | | 2 | .2130 | | | 1.1250 | 1 1/4 - 12 | |
| 1 | .0260 | | 1 | .2188 | | 1 11/64 | 1.1719 | 1 3/8 - 6 | |
| 1 | .0280 | | A | .2210 | | 1 7/32 | 1.2188 | | |
| 1 | .0292 | | | .2280 | | | 1.2500 | 1 3/8 - 12 | |
| 1 | .0310 | | | .2340 | | 1 19/64 | 1.2969 | 1 1/2 - 6 | |
| 1 | .0312 | | | .2380 | | 1 11/32 | 1.3438 | | |
| 1 | .0320 | | | .2420 | | | 1.3750 | 1 1/2 - 12 | |
| 1 | .0330 | | | .2460 | | 1 27/64 | 1.4219 | | |
| 1 | .0350 | | | .2500 | | | 1.5000 | | |
| 1 | .0360 | | | .2570 | 5/16 - 18 | | | | |
| 1 | .0370 | | | .2610 | | | | | |
| 1 | .0380 | | | .2656 | | | | | |
| 1 | .0390 | | | .2660 | | | | | |
| 1 | .0400 | | | .2720 | | | | | |
| 1 | .0410 | | | .2770 | 5/16 - 24 | | | | |
| 1 | .0420 | | | .2810 | | | | | |
| 1 | .0430 | | | .2812 | | | | | |
| 1 | .0465 | | | .2860 | | | | | |
| 1 | .0489 | | | .2900 | | | | | |
| 1 | .0520 | 0 - 80 | | .2950 | | | | | |
| 1 | .0550 | | | .2969 | | | | | |
| 1 | .0555 | 1 - 64, 72 | | .3020 | | | | | |
| 1 | .0625 | | | .3125 | | | | | |
| 1 | .0635 | | | .3160 | 3/8 - 16 | | | | |
| 1 | .0670 | | | .3230 | | | | | |
| 1 | .0700 | 2 - 56, 64 | | .3281 | | | | | |
| 1 | .0730 | | | .3320 | | | | | |
| 1 | .0760 | | | .3438 | 3/8 - 24 | | | | |
| 1 | .0785 | | | .3480 | | | | | |
| 1 | .0820 | 3 - 48 | | .3580 | | | | | |
| 1 | .0860 | | | .3594 | | | | | |
| 1 | .0890 | 3 - 56 | | .3680 | | | | | |
| 1 | .0920 | | | .3750 | 7/16 - 14 | | | | |
| 1 | .0935 | 4 - 40 | | .3770 | | | | | |
| 1 | .0940 | 4 - 48 | | .3860 | | | | | |
| 1 | .0984 | | | .3906 | | | | | |
| 1 | .1004 | 5 - 40 | | .3970 | 7/16 - 20 | | | | |
| 1 | .1080 | 5 - 44 | | .4040 | | | | | |
| 1 | .1100 | 6 - 32 | | .4062 | | | | | |
| 1 | .1110 | | | .4130 | | | | | |
| 1 | .1130 | | | .4219 | | | | | |
| 1 | .1160 | | | .4375 | 1/2 - 13 | | | | |
| 1 | .1190 | | | .4531 | | | | | |
| 1 | .1250 | 6 - 40 | | .4688 | 1/2 - 20 | | | | |
| 1 | .1250 | | | .4844 | | | | | |
| 1 | .1295 | | | .5000 | 9/16 - 12 | | | | |
| 1 | .1360 | 8 - 32, 36 | | .5156 | | | | | |
| 1 | .1405 | | | .5312 | 9/16 - 18 | | | | |
| 1 | .1408 | | | .5469 | 5/8 - 11 | | | | |
| 1 | .1440 | | | .5625 | | | | | |
| 1 | .1470 | | | .5781 | 5/8 - 18 | | | | |
| 1 | .1495 | | | .5938 | | | | | |
| 1 | .1520 | 10 - 24 | | .6094 | 5/8 - 11 | | | | |
| 1 | .1540 | | | .6250 | 5/8 - 18 | | | | |
| 1 | .1562 | | | .6406 | | | | | |
| 1 | .1570 | | | .6562 | 3/4 - 10 | | | | |
| 1 | .1570 | | | .6719 | | | | | |
| 1 | .1590 | | | .6875 | 3/4 - 16 | | | | |
| 1 | .1610 | 10 - 32 | | .7031 | | | | | |
| 1 | .1665 | | | .7188 | | | | | |
| 1 | .1719 | | | .7344 | | | | | |
| 1 | .1730 | | | .7500 | | | | | |
| 1 | .1770 | | | .7656 | | | | | |
| 1 | .1800 | | | .7812 | | | | | |
| 1 | .1820 | | | .7969 | | | | | |
| 1 | .1850 | | | .8125 | | | | | |
| 1 | .1875 | | | .8281 | | | | | |
| 1 | .1890 | | | .8438 | | | | | |
| 1 | .1950 | | | .8594 | | | | | |
| 1 | | | | .8750 | | | | | |

METRIC TAP DRILL SIZES

| METRIC TAP | TAP DRILL (mm) | DECIMAL (inch) |
|-------------|----------------|----------------|
| M1.6 x 0.35 | 1.25 | .0492 |
| M1.8 x 0.35 | 1.45 | .0571 |
| M2 x 0.4 | 1.60 | .0630 |
| M2.2 x 0.45 | 1.75 | .0689 |
| M2.5 x 0.45 | 2.05 | .0807 |
| M3 x 0.5 | 2.50 | .0984 |
| M3.5 x 0.6 | 2.90 | .1142 |
| M4 x 0.7 | 3.30 | .1299 |
| M4.5 x 0.75 | 3.70 | .1457 |
| M5 x 0.8 | 4.20 | .1654 |
| M6 x 1 | 5.00 | .1968 |
| M7 x 1 | 6.00 | .2362 |
| M8 x 1.25 | 6.70 | .2638 |
| M8 x 1 | 7.00 | .2756 |
| M10 x 1.5 | 8.50 | .3346 |
| M10 x 1.25 | 8.70 | .3425 |
| M12 x 1.75 | 10.20 | .4016 |
| M12 x 1.25 | 10.80 | .4252 |
| M14 x 2 | 12.00 | .4724 |
| M14 x 1.5 | 12.50 | .4921 |
| M16 x 2 | 14.00 | .5512 |
| M16 x 1.5 | 14.50 | .5709 |
| M18 x 2.5 | 16.50 | .6102 |
| M18 x 1.5 | 17.50 | .6496 |
| M20 x 2.5 | 18.50 | .6890 |
| M20 x 1.5 | 19.50 | .7283 |
| M22 x 1.5 | 20.50 | .7677 |
| M24 x 3 | 21.00 | .8071 |
| M24 x 2 | 22.00 | .8268 |
| M27 x 3 | 24.00 | .8661 |
| M27 x 2 | 25.00 | .9449 |
| M30 x 3.5 | 26.50 | .9843 |
| M30 x 2 | 28.00 | 1.0433 |
| M33 x 3.5 | 29.50 | 1.1024 |
| M33 x 2 | 31.00 | 1.1614 |
| M36 x 4 | 32.00 | 1.2205 |
| M36 x 3 | 33.00 | 1.2598 |
| M39 x 4 | 35.00 | 1.2992 |
| M39 x 3 | 36.00 | 1.3780 |

REFERENCE TABLES

starrett.com

METRIC AND ENGLISH EQUIVALENTS

| Linear Measure | |
|---|---|
| Metric to Inch | Inch to Metric |
| 1 millimeter = 0.03937 inch | 1 inch = 25.4 millimeters = 2.54 centimeters |
| 1 centimeter = 0.3937 inch | 1 foot = 304.8 millimeters = 0.3048 meter |
| 1 meter = 39.37 inches = 3.2808 feet = 1.0936 yards | 1 yard = 0.9144 meter |
| 1 kilometer = 0.6214 mile | 1 mile = 1.609 kilometers |
| Square Measure | |
| Metric to Inch | Inch to Metric |
| 1 square millimeter = 0.00155 square inch | 1 square inch = 6.452 square centimeters = 645.2 square millimeters |
| 1 square centimeter = 0.155 square inch | 1 square foot = 0.0929 square meter = 929 square centimeters |
| 1 square meter = 10.764 square feet = 1.196 square yards | 1 square yard = 0.836 square meter |
| 1 are = 0.0247 acre = 1076.4 square feet | 1 acre = 0.4047 hectare = 40.47 ares |
| 1 hectare = 2.471 acres = 107,639 square feet | 1 square mile = 2.5900 square kilometers |
| 1 square kilometer = 0.3861 square mile = 247.1 acres | |
| Cubic Measure | |
| Metric to English | English to Metric |
| 1 liter = 0.2642 U.S. gallon = 1.0567 U.S. quarts | 1 U.S. quart = 0.946 liter |
| 1 liter (cubic decimeter) = 0.0353 cubic foot = 61.024 cubic inches | 1 U.S. gallon = 3.785 liters = 231 cubic inches |
| 1 cubic centimeter = 0.061 cubic inch | 1 cubic inch = 16.38706 cubic centimeters |
| 1 cubic meter = 264.2 U.S. gallons | 1 cubic foot = 0.02832 cubic meter = 28.317 liters |
| 1 cubic meter = 35.315 cubic feet = 1.308 cubic yards | 1 cubic yard = 0.7646 cubic meter |
| Weight | |
| Metric to English | English to Metric |
| 1 gram = 15.432 grains | 1 grain = 0.0648 gram |
| 1 gram = 0.03527 ounce avoirdupois (Commercial) | 1 ounce avoirdupois (Commercial) = 28.35 grams |
| 1 kilogram = 2.2046 pounds = 35.274 ounces avoirdupois (Commercial) | 1 pound = 0.4536 kilogram = 453.6 grams |
| 1 metric ton = 0.9842 ton (of 2240 pounds) = 2204.6 pounds | 1 short ton (2,000 pounds) = .907 metric ton = 907 kilograms |



INCH TO MILLIMETER CONVERSIONS

| Decimal | mm |
|---------|---------|
| 0.001 | 0.0254 |
| 0.002 | 0.0508 |
| 0.003 | 0.0762 |
| 0.004 | 0.1016 |
| 0.005 | 0.1270 |
| 0.006 | 0.1524 |
| 0.007 | 0.1778 |
| 0.008 | 0.2032 |
| 0.009 | 0.2286 |
| 0.010 | 0.2540 |
| 0.020 | 0.5080 |
| 0.030 | 0.7620 |
| 0.040 | 1.0160 |
| 0.050 | 1.2700 |
| 0.060 | 1.5240 |
| 0.070 | 1.7780 |
| 0.080 | 2.0320 |
| 0.090 | 2.2860 |
| 0.100 | 2.5400 |
| 0.110 | 2.7940 |
| 0.120 | 3.0480 |
| 0.130 | 3.3020 |
| 0.140 | 3.5560 |
| 0.150 | 3.8100 |
| 0.160 | 4.0640 |
| 0.170 | 4.3180 |
| 0.180 | 4.5720 |
| 0.190 | 4.8260 |
| 0.200 | 5.0800 |
| 0.210 | 5.3340 |
| 0.220 | 5.5880 |
| 0.230 | 5.8420 |
| 0.240 | 6.0960 |
| 0.250 | 6.3500 |
| 0.260 | 6.6040 |
| 0.270 | 6.8580 |
| 0.280 | 7.1120 |
| 0.290 | 7.3660 |
| 0.300 | 7.6200 |
| 0.310 | 7.8740 |
| 0.320 | 8.1280 |
| 0.330 | 8.3820 |
| 0.340 | 8.6360 |
| 0.350 | 8.8900 |
| 0.360 | 9.1440 |
| 0.370 | 9.3980 |
| 0.380 | 9.6520 |
| 0.390 | 9.9060 |
| 0.400 | 10.1600 |
| 0.410 | 10.4140 |
| 0.420 | 10.6680 |
| 0.430 | 10.9220 |
| 0.440 | 11.1760 |
| 0.450 | 11.4300 |
| 0.460 | 11.6840 |
| 0.470 | 11.9380 |
| 0.480 | 12.1920 |
| 0.490 | 12.4460 |

| Decimal | mm |
|---------|---------|
| 0.500 | 12.7000 |
| 0.510 | 12.9540 |
| 0.520 | 13.2080 |
| 0.530 | 13.4620 |
| 0.540 | 13.7160 |
| 0.550 | 13.9700 |
| 0.560 | 14.2240 |
| 0.570 | 14.4780 |
| 0.580 | 14.7320 |
| 0.590 | 14.9860 |
| 0.600 | 15.2400 |
| 0.610 | 15.4940 |
| 0.620 | 15.7480 |
| 0.630 | 16.0020 |
| 0.640 | 16.2560 |
| 0.650 | 16.5100 |
| 0.660 | 16.7640 |
| 0.670 | 17.0180 |
| 0.680 | 17.2720 |
| 0.690 | 17.5260 |
| 0.700 | 17.7800 |
| 0.710 | 18.0340 |
| 0.720 | 18.2880 |
| 0.730 | 18.5420 |
| 0.740 | 18.7960 |
| 0.750 | 19.0500 |
| 0.760 | 19.3040 |
| 0.770 | 19.5580 |
| 0.780 | 19.8120 |
| 0.790 | 20.0660 |
| 0.800 | 20.3200 |
| 0.810 | 20.5740 |
| 0.820 | 20.8280 |
| 0.830 | 21.0820 |
| 0.840 | 21.3360 |
| 0.850 | 21.5900 |
| 0.860 | 21.8440 |
| 0.870 | 22.0980 |
| 0.880 | 22.3520 |
| 0.890 | 22.6060 |
| 0.900 | 22.8600 |
| 0.910 | 23.1140 |
| 0.920 | 23.3680 |
| 0.930 | 23.6220 |
| 0.940 | 23.8760 |
| 0.950 | 24.1300 |
| 0.960 | 24.3840 |
| 0.970 | 24.6380 |
| 0.980 | 24.8920 |
| 0.990 | 25.1460 |
| 1.000 | 25.4000 |

| Fraction | Decimal | mm |
|----------|---------|---------|
| 1/64 | 0.0156 | 0.3969 |
| 1/32 | 0.0313 | 0.7938 |
| 3/64 | 0.0469 | 1.1906 |
| 1/16 | 0.0625 | 1.5875 |
| 5/64 | 0.0781 | 1.9844 |
| 3/32 | 0.0938 | 2.3812 |
| 7/64 | 0.1094 | 2.7781 |
| 1/8 | 0.1250 | 3.1750 |
| 9/64 | 0.1406 | 3.5719 |
| 5/32 | 0.1563 | 3.9688 |
| 11/64 | 0.1719 | 4.3656 |
| 3/16 | 0.1875 | 4.7625 |
| 13/64 | 0.2031 | 5.1594 |
| 7/32 | 0.2188 | 5.5562 |
| 15/64 | 0.2344 | 5.9531 |
| 1/4 | 0.2500 | 6.3500 |
| 17/64 | 0.2656 | 6.7469 |
| 9/32 | 0.2813 | 7.1438 |
| 19/64 | 0.2969 | 7.5406 |
| 5/16 | 0.3125 | 7.9375 |
| 21/64 | 0.3281 | 8.3344 |
| 11/32 | 0.3438 | 8.7312 |
| 23/64 | 0.3594 | 9.1281 |
| 3/8 | 0.3750 | 9.5250 |
| 25/64 | 0.3906 | 9.9219 |
| 13/32 | 0.4063 | 10.3188 |
| 27/64 | 0.4219 | 10.7156 |
| 7/16 | 0.4375 | 11.1125 |
| 29/64 | 0.4531 | 11.5094 |
| 15/32 | 0.4688 | 11.9062 |
| 31/64 | 0.4844 | 12.3031 |
| 1/2 | 0.5000 | 12.7000 |
| 33/64 | 0.5156 | 13.0969 |
| 17/32 | 0.5313 | 13.4938 |
| 35/64 | 0.5469 | 13.8906 |
| 9/16 | 0.5625 | 14.2875 |
| 37/64 | 0.5781 | 14.6844 |
| 19/32 | 0.5938 | 15.0812 |
| 39/64 | 0.6094 | 15.4781 |
| 5/8 | 0.6250 | 15.8750 |
| 41/64 | 0.6406 | 16.2719 |
| 21/32 | 0.6563 | 16.6688 |
| 43/64 | 0.6719 | 17.0656 |
| 11/16 | 0.6875 | 17.4625 |
| 45/64 | 0.7031 | 17.8594 |
| 23/32 | 0.7188 | 18.2562 |
| 47/64 | 0.7344 | 18.6531 |
| 3/4 | 0.7500 | 19.0500 |
| 49/64 | 0.7656 | 19.4469 |
| 25/32 | 0.7813 | 19.8438 |
| 51/64 | 0.7969 | 20.2406 |
| 13/16 | 0.8125 | 20.6375 |
| 53/64 | 0.8281 | 21.0344 |
| 27/32 | 0.8438 | 21.4312 |
| 55/64 | 0.8594 | 21.8281 |
| 7/8 | 0.8750 | 22.2250 |
| 57/64 | 0.8906 | 22.6219 |
| 29/32 | 0.9063 | 23.0188 |
| 59/64 | 0.9219 | 23.4156 |
| 15/16 | 0.9375 | 23.8125 |
| 61/64 | 0.9531 | 24.2094 |
| 31/32 | 0.9688 | 24.6062 |
| 63/64 | 0.9844 | 25.0031 |
| 1 | 1.0000 | 25.4000 |



MILLIMETER TO INCH CONVERSIONS

| mm | Decimal |
|------|---------|
| 0.01 | .00039 |
| 0.02 | .00079 |
| 0.03 | .00118 |
| 0.04 | .00157 |
| 0.05 | .00197 |
| 0.06 | .00236 |
| 0.07 | .00276 |
| 0.08 | .00315 |
| 0.09 | .00354 |
| 0.10 | .00394 |
| 0.11 | .00433 |
| 0.12 | .00472 |
| 0.13 | .00512 |
| 0.14 | .00551 |
| 0.15 | .00591 |
| 0.16 | .00630 |
| 0.17 | .00669 |
| 0.18 | .00709 |
| 0.19 | .00748 |
| 0.20 | .00787 |
| 0.21 | .00827 |
| 0.22 | .00866 |
| 0.23 | .00906 |
| 0.24 | .00945 |
| 0.25 | .00984 |
| 0.26 | .01024 |
| 0.27 | .01063 |
| 0.28 | .01102 |
| 0.29 | .01142 |
| 0.30 | .01181 |
| 0.31 | .01220 |
| 0.32 | .01260 |
| 0.33 | .01299 |
| 0.34 | .01339 |
| 0.35 | .01378 |
| 0.36 | .01417 |
| 0.37 | .01457 |
| 0.38 | .01496 |
| 0.39 | .01535 |
| 0.40 | .01575 |
| 0.41 | .01614 |
| 0.42 | .01654 |
| 0.43 | .01693 |
| 0.44 | .01732 |
| 0.45 | .01772 |
| 0.46 | .01811 |
| 0.47 | .01850 |
| 0.48 | .01890 |
| 0.49 | .01929 |
| 0.50 | .01969 |
| 0.51 | .02008 |
| 0.52 | .02047 |
| 0.53 | .02087 |
| 0.54 | .02126 |
| 0.55 | .02165 |
| 0.56 | .02205 |
| 0.57 | .02244 |
| 0.58 | .02283 |
| 0.59 | .02323 |
| 0.60 | .02362 |
| 0.61 | .02402 |
| 0.62 | .02441 |
| 0.63 | .02480 |

| mm | Decimal |
|------|---------|
| 0.64 | .02520 |
| 0.65 | .02559 |
| 0.66 | .02598 |
| 0.67 | .02638 |
| 0.68 | .02677 |
| 0.69 | .02717 |
| 0.70 | .02756 |
| 0.71 | .02795 |
| 0.72 | .02835 |
| 0.73 | .02874 |
| 0.74 | .02913 |
| 0.75 | .02953 |
| 0.76 | .02992 |
| 0.77 | .03031 |
| 0.78 | .03071 |
| 0.79 | .03110 |
| 0.80 | .03150 |
| 0.81 | .03189 |
| 0.82 | .03228 |
| 0.83 | .03268 |
| 0.84 | .03307 |
| 0.85 | .03346 |
| 0.86 | .03386 |
| 0.87 | .03425 |
| 0.88 | .03465 |
| 0.89 | .03504 |
| 0.90 | .03543 |
| 0.91 | .03583 |
| 0.92 | .03622 |
| 0.93 | .03661 |
| 0.94 | .03701 |
| 0.95 | .03740 |
| 0.96 | .03780 |
| 0.97 | .03819 |
| 0.98 | .03858 |
| 0.99 | .03898 |
| 1.00 | .03937 |
| 1 | .03937 |
| 2 | .07874 |

| mm | Decimal |
|----|---------|
| 3 | .11811 |
| 4 | .15748 |
| 5 | .19685 |
| 6 | .23622 |
| 7 | .27559 |
| 8 | .31496 |
| 9 | .35433 |
| 10 | .39370 |
| 11 | .43307 |
| 12 | .47244 |
| 13 | .51181 |
| 14 | .55118 |
| 15 | .59055 |
| 16 | .62992 |
| 17 | .66929 |
| 18 | .70866 |
| 19 | .74803 |
| 20 | .78740 |
| 21 | .82677 |
| 22 | .86614 |
| 23 | .90551 |
| 24 | .94488 |
| 25 | .98425 |
| 26 | 1.02362 |
| 27 | 1.06299 |
| 28 | 1.10236 |
| 29 | 1.14173 |
| 30 | 1.18110 |
| 31 | 1.22047 |
| 32 | 1.25984 |
| 33 | 1.29921 |
| 34 | 1.33858 |
| 35 | 1.37795 |
| 36 | 1.41732 |
| 37 | 1.45669 |
| 38 | 1.49606 |
| 39 | 1.53543 |
| 40 | 1.57480 |
| 41 | 1.61417 |
| 42 | 1.65354 |
| 43 | 1.69291 |
| 44 | 1.73228 |
| 45 | 1.77165 |
| 46 | 1.81102 |
| 47 | 1.85039 |
| 48 | 1.88976 |
| 49 | 1.92913 |
| 50 | 1.96850 |
| 51 | 2.00787 |
| 52 | 2.04724 |
| 53 | 2.08661 |
| 54 | 2.12598 |
| 55 | 2.16535 |
| 56 | 2.20472 |
| 57 | 2.24409 |
| 58 | 2.28346 |
| 59 | 2.32283 |
| 60 | 2.36220 |
| 61 | 2.40157 |
| 62 | 2.44094 |
| 63 | 2.48031 |
| 64 | 2.51969 |
| 65 | 2.55906 |

| mm | Decimal |
|-----|---------|
| 66 | 2.59843 |
| 67 | 2.63780 |
| 68 | 2.67717 |
| 69 | 2.71654 |
| 70 | 2.75591 |
| 71 | 2.79528 |
| 72 | 2.83465 |
| 73 | 2.87402 |
| 74 | 2.91339 |
| 75 | 2.95276 |
| 76 | 2.99213 |
| 77 | 3.03150 |
| 78 | 3.07087 |
| 79 | 3.11024 |
| 80 | 3.14961 |
| 81 | 3.18898 |
| 82 | 3.22835 |
| 83 | 3.26772 |
| 84 | 3.30709 |
| 85 | 3.34646 |
| 86 | 3.38583 |
| 87 | 3.42520 |
| 88 | 3.46457 |
| 89 | 3.50394 |
| 90 | 3.54331 |
| 91 | 3.58268 |
| 92 | 3.62205 |
| 93 | 3.66142 |
| 94 | 3.70079 |
| 95 | 3.74016 |
| 96 | 3.77953 |
| 97 | 3.81890 |
| 98 | 3.85827 |
| 99 | 3.89764 |
| 100 | 3.93701 |



DECIMAL EQUIVALENTS OF 8THS, 16THS, 32NDS AND 64THS

| 8ths | 32nds | 64ths | 64ths |
|------------|----------------|-----------------|-----------------|
| 1/8 = .125 | 1/32 = .03125 | 1/64 = .015625 | 37/64 = .578125 |
| 1/4 = .250 | 3/32 = .09375 | 3/64 = .046875 | 39/64 = .609375 |
| 3/8 = .375 | 5/32 = .15625 | 5/64 = .078125 | 41/64 = .640625 |
| 1/2 = .500 | 7/32 = .21875 | 7/64 = .109375 | 43/64 = .671875 |
| 5/8 = .625 | 9/32 = .28125 | 9/64 = .140625 | 45/64 = .703125 |
| 3/4 = .750 | 11/32 = .34375 | 11/64 = .171875 | 47/64 = .734375 |
| 7/8 = .875 | 13/32 = .40625 | 13/64 = .203125 | 49/64 = .765625 |
| | 15/32 = .46875 | 15/64 = .234375 | 51/64 = .796875 |
| | 17/32 = .53125 | 17/64 = .265625 | 53/64 = .828125 |
| | 19/32 = .59375 | 19/64 = .296875 | 55/64 = .859375 |
| | 21/32 = .65625 | 21/64 = .328125 | 57/64 = .890625 |
| | 23/32 = .71875 | 23/64 = .359375 | 59/64 = .921875 |
| | 25/32 = .78125 | 25/64 = .390625 | 61/64 = .953125 |
| | 27/32 = .84375 | 27/64 = .421875 | 63/64 = .984375 |
| | 29/32 = .90625 | 29/64 = .453125 | |
| | 31/32 = .96875 | 31/64 = .484375 | |
| | | 33/64 = .515625 | |
| | | 35/64 = .546875 | |

| 16ths |
|---------------|
| 1/16 = .0625 |
| 3/16 = .1875 |
| 5/16 = .3125 |
| 7/16 = .4375 |
| 9/16 = .5625 |
| 11/16 = .6875 |
| 13/16 = .8125 |
| 15/16 = .9375 |

DECIMAL EQUIVALENTS OF LETTER SIZE DRILLS

| Letter | Size of Drill in Inches | Letter | Size of Drill in Inches | Letter | Size of Drill in Inches |
|--------|-------------------------|--------|-------------------------|--------|-------------------------|
| A | .234 | K | .281 | T | .358 |
| B | .238 | L | .290 | U | .368 |
| C | .242 | M | .295 | V | .377 |
| D | .246 | N | .302 | W | .386 |
| E | .250 | O | .316 | X | .397 |
| F | .257 | P | .323 | Y | .404 |
| G | .261 | Q | .332 | Z | .413 |
| H | .266 | R | .339 | | |
| I | .272 | S | .348 | | |
| J | .277 | | | | |

DECIMAL EQUIVALENTS OF NUMBER SIZE DRILLS

| No. | Size of Drill in Inches | No. | Size of Drill in Inches | No. | Size of Drill in Inches | No. | Size of Drill in Inches | No. | Size of Drill in Inches | No. | Size of Drill in Inches |
|-----|-------------------------|-----|-------------------------|-----|-------------------------|-----|-------------------------|-----|-------------------------|-----|-------------------------|
| 1 | .2280 | 15 | .1800 | 29 | .1360 | 43 | .0890 | 57 | .0430 | 69 | .0292 |
| 2 | .2210 | 16 | .1770 | 30 | .1285 | 44 | .0860 | 58 | .0420 | 70 | .0280 |
| 3 | .2130 | 17 | .1730 | 31 | .1200 | 45 | .0820 | 59 | .0410 | 71 | .0260 |
| 4 | .2090 | 18 | .1695 | 32 | .1160 | 46 | .0810 | 60 | .0400 | 72 | .0250 |
| 5 | .2055 | 19 | .1660 | 33 | .1130 | 47 | .0785 | 61 | .0390 | 73 | .0240 |
| 6 | .2040 | 20 | .1610 | 34 | .1110 | 48 | .0760 | 62 | .0380 | 74 | .0225 |
| 7 | .2010 | 21 | .1590 | 35 | .1100 | 49 | .0730 | 63 | .0370 | 75 | .0210 |
| 8 | .1990 | 22 | .1570 | 36 | .1065 | 50 | .0700 | 64 | .0360 | 76 | .0200 |
| 9 | .1960 | 23 | .1540 | 37 | .1040 | 51 | .0670 | 65 | .0350 | 77 | .0180 |
| 10 | .1935 | 24 | .1520 | 38 | .1015 | 52 | .0635 | 66 | .0330 | 78 | .0160 |
| 11 | .1910 | 25 | .1495 | 39 | .0995 | 53 | .0595 | 67 | .0320 | 79 | .0145 |
| 12 | .1890 | 26 | .1470 | 40 | .0980 | 54 | .0550 | 68 | .0310 | 80 | .0135 |
| 13 | .1850 | 27 | .1440 | 41 | .0960 | 55 | .0520 | | | | |
| 14 | .1820 | 28 | .1405 | 42 | .0935 | 56 | .0465 | | | | |

AMERICAN STANDARD PIPE THREAD AND TAP DRILL SIZES

| Pipe Size (in) | Threads Per Inch | Root Diameter Small End of Pipe and Gage | Tap Drill Taper NPT | Straight NPS |
|----------------|------------------|--|---------------------|--------------|
| 1/8 | 27 | .3339" | Q | 11/32" |
| 1/4 | 18 | .4329" | 7/16" | 7/16" |
| 3/8 | | .5676" | 9/16" | 37/64" |
| 1/2 | 14 | .7013" | 45/64" | 23/32" |
| 3/4 | | .9105" | 29/32" | 59/64" |
| 1 | | 1.1441" | 1-9/64" | 1-5/32" |
| 1-1/4 | | 1.4876" | 1-31/64" | 1-1/2" |
| 1-1/2 | 11-1/2 | 1.7265" | 1-47/64" | 1-3/4" |
| 2 | | 2.1995" | 2-13/64" | 2-7/32" |



AMERICAN NATIONAL AND UNIFIED COARSE AND FINE THREAD DIMENSIONS AND TAP DRILL SIZES

$$p = \text{pitch} = \frac{1}{\text{thread per inch}}$$

$$d = \text{depth} = p \times .649519$$

$$f = \text{flat} = \frac{p}{8}$$

$$\text{pitch diameter} = D - \frac{.6495}{N}$$

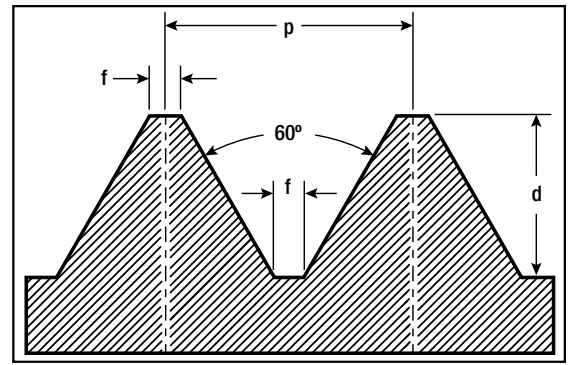

| Size | Threads per inch UNC UNF | NC NF | Outside Diameter (in) | Pitch Diameter (in) | Root Diameter (in) | Tap Drill Approx. 75% Full Thread | Decimal Equiv. of Tap Drill |
|--------|--------------------------------|----------|-----------------------|---------------------|--------------------|--------------------------------------|--------------------------------|
| 0 | — | 80 | .0600 | .0519 | .0438 | 3/64" | .0469 |
| 1 | 64 | — | .0730 | .0629 | .0527 | 53 | .0595 |
| 1 | — | 72 | .0730 | .0640 | .0550 | 53 | .0595 |
| 2 | 56 | — | .0860 | .0744 | .0628 | 50 | .0700 |
| 2 | — | 64 | .0860 | .0759 | .0657 | 50 | .0700 |
| 3 | 48 | — | .0990 | .0855 | .0719 | 47 | .0785 |
| 3 | — | 56 | .0990 | .0874 | .0758 | 46 | .0810 |
| 4 | 40 | — | .1120 | .0958 | .0795 | 43 | .0890 |
| 4 | — | 48 | .1120 | .0985 | .0849 | 42 | .0935 |
| 5 | 40 | — | .1250 | .1088 | .0925 | 38 | .1015 |
| 5 | — | 44 | .1250 | .1102 | .0955 | 37 | .1040 |
| 6 | 32 | — | .1380 | .1177 | .0974 | 36 | .1065 |
| 6 | — | 40 | .1380 | .1218 | .1055 | 33 | .1130 |
| 8 | 32 | — | .1640 | .1437 | .1234 | 29 | .1360 |
| 8 | — | 36 | .1640 | .1460 | .1279 | 29 | .1360 |
| 10 | 24 | — | .1900 | .1629 | .1359 | 26 | .1470 |
| 10 | — | 32 | .1900 | .1697 | .1494 | 21 | .1590 |
| 12 | 24 | — | .2160 | .1889 | .1619 | 16 | .1770 |
| 12 | — | 28 | .2160 | .1928 | .1696 | 15 | .1800 |
| 1/4" | 20 | — | .2500 | .2175 | .1850 | 7 | .2010 |
| 1/4" | — | 28 | .2500 | .2268 | .2036 | 3 | .2130 |
| 5/16" | 18 | — | .3125 | .2764 | .2403 | F | .2570 |
| 5/16" | — | 24 | .3125 | .2854 | .2584 | I | .2720 |
| 3/8" | 16 | — | .3750 | .3344 | .2938 | 5/16" | .3125 |
| 3/8" | — | 24 | .3750 | .3479 | .3209 | Q | .3320 |
| 7/16" | 14 | — | .4375 | .3911 | .3447 | U | .3680 |
| 7/16" | — | 20 | .4375 | .4050 | .3726 | 25/64" | .3906 |
| 1/2" | 13 | — | .5000 | .4500 | .4001 | 27/64" | .4219 |
| 1/2" | — | 20 | .5000 | .4675 | .4351 | 29/64" | .4531 |
| 9/16" | 12 | — | .5625 | .5084 | .4542 | 31/64" | .4844 |
| 9/16" | — | 18 | .5625 | .5264 | .4903 | 33/64" | .5156 |
| 5/8" | 11 | — | .6250 | .5660 | .5069 | 17/32" | .5312 |
| 5/8" | — | 18 | .6250 | .5889 | .5528 | 37/64" | .5781 |
| 3/4" | 10 | — | .7500 | .6850 | .6201 | 21/32" | .6562 |
| 3/4" | — | 16 | .7500 | .7094 | .6688 | 11/16" | .6875 |
| 7/8" | 9 | — | .8750 | .8028 | .7307 | 49/64" | .7656 |
| 7/8" | — | 14 | .8750 | .8286 | .7822 | 13/16" | .8125 |
| 1" | 8 | — | 1.0000 | .9188 | .8376 | 7/8" | .8750 |
| 1" | — | 12 | 1.0000 | .9459 | .8917 | 59/64" | .9219 |
| 1-1/8" | 7 | — | 1.1250 | 1.0322 | .9394 | 63/64" | .9844 |
| 1-1/8" | — | 12 | 1.1250 | 1.0709 | 1.0168 | 1-3/64" | 1.0469 |
| 1-1/4" | 7 | — | 1.2500 | 1.1572 | 1.0644 | 1-7/64" | 1.1094 |
| 1-1/4" | — | 12 | 1.2500 | 1.1959 | 1.1418 | 1-11/64" | 1.1719 |
| 1-3/8" | 6 | — | 1.3750 | 1.2667 | 1.1585 | 1-7/32" | 1.2187 |
| 1-3/8" | — | 12 | 1.3750 | 1.3209 | 1.2668 | 1-19/64" | 1.2969 |
| 1-1/2" | 6 | — | 1.5000 | 1.3917 | 1.2835 | 1-11/32" | 1.3437 |
| 1-1/2" | — | 12 | 1.5000 | 1.4459 | 1.3918 | 1-27/64" | 1.4219 |
| 1-3/4" | 5 | — | 1.7500 | 1.6201 | 1.4902 | 1-9/16" | 1.5625 |
| 2" | 4-1/2 | — | 2.0000 | 1.8557 | 1.7113 | 1-25/32" | 1.7812 |
| 2-1/4" | 4-1/2 | — | 2.2500 | 2.1057 | 1.9613 | 2-1/32" | 2.0313 |
| 2-1/2" | 4-1/2 | — | 2.5000 | 2.3376 | 2.1752 | 2-1/4" | 2.2500 |
| 2-3/4" | 4 | — | 2.7500 | 2.5876 | 2.4252 | 2-1/2" | 2.5000 |
| 3" | 4 | — | 3.0000 | 2.8376 | 2.6752 | 2-3/4" | 2.7500 |
| 3-1/4" | 4 | — | 3.2500 | 3.0876 | 2.9252 | 3" | 3.0000 |
| 3-1/2" | 4 | — | 3.5000 | 3.3376 | 3.1752 | 3-1/4" | 3.2500 |
| 3-3/4" | 4 | — | 3.7500 | 3.5876 | 3.4252 | 3-1/2" | 3.5000 |
| 4" | 4 | — | 4.0000 | 3.3786 | 3.6752 | 3-3/4" | 3.7500 |



MILLIMETER TAP DRILL SIZES

| Metric Tap | Tap Drill (mm) | Decimal Equiv. (in) |
|-------------|----------------|---------------------|
| M1.6 x 0.35 | 1.25 | .0492 |
| M1.8 x 0.35 | 1.45 | .0571 |
| M2 x 0.4 | 1.60 | .0630 |
| M2.2 x 0.45 | 1.75 | .0689 |
| M2.5 x 0.45 | 2.05 | .0807 |
| M3 x 0.5 | 2.50 | .0984 |
| M3.5 x 0.6 | 2.90 | .1142 |
| M4 x 0.7 | 3.30 | .1299 |
| M4.5 x 0.75 | 3.70 | .1457 |
| M5 x 0.8 | 4.20 | .1654 |
| M6 x 1 | 5.00 | .1968 |
| M7 x 1 | 6.00 | .2362 |
| M8 x 1.25 | 6.70 | .2638 |
| M8 x 1 | 7.00 | .2756 |

| Metric Tap | Tap Drill (mm) | Decimal Equiv. (in) |
|------------|----------------|---------------------|
| M10 x 1.5 | 8.50 | .3346 |
| M10 x 1.25 | 8.70 | .3425 |
| M12 x 1.75 | 10.20 | .4016 |
| M12 x 1.25 | 10.80 | .4252 |
| M14 x 2 | 12.00 | .4724 |
| M14 x 1.5 | 12.50 | .4921 |
| M16 x 2 | 14.00 | .5512 |
| M16 x 1.5 | 14.50 | .5709 |
| M18 x 2.5 | 15.50 | .6102 |
| M18 x 1.5 | 16.50 | .6496 |
| M20 x 2.5 | 17.50 | .6890 |
| M20 x 1.5 | 18.50 | .7283 |
| M22 x 2.5 | 19.50 | .7677 |
| M22 x 1.5 | 20.50 | .8071 |

| Metric Tap | Tap Drill (mm) | Decimal Equiv. (in) |
|------------|----------------|---------------------|
| M24 x 3 | 21.00 | .8268 |
| M24 x 2 | 22.00 | .8661 |
| M27 x 3 | 24.00 | .9449 |
| M27 x 2 | 25.00 | .9843 |
| M30 x 3.5 | 26.50 | 1.0433 |
| M30 x 2 | 28.00 | 1.1024 |
| M33 x 3.5 | 29.50 | 1.1614 |
| M33 x 2 | 31.00 | 1.2205 |
| M36 x 4 | 32.00 | 1.2598 |
| M36 x 3 | 33.00 | 1.2992 |
| M39 x 4 | 35.00 | 1.3780 |
| M39 x 3 | 36.00 | 1.4173 |

TAP DRILL SIZES FOR FRACTIONAL SIZE THREADS

APPROXIMATELY 65% DEPTH THREAD/AMERICAN NATIONAL THREAD FORM

| Tap Size | Threads per Inch | Hole Diameter | Drill |
|----------|------------------|---------------|-------|
| 1/16 | 72 | .049 | 3/64 |
| 1/16 | 64 | .047 | 3/64 |
| 1/16 | 60 | .046 | 56 |
| 5/64 | 72 | .065 | 52 |
| 5/64 | 64 | .063 | 1/16 |
| 5/64 | 60 | .062 | 1/16 |
| 5/64 | 56 | .061 | 53 |
| 3/32 | 60 | .077 | 5/64 |
| 3/32 | 56 | .076 | 48 |
| 3/32 | 50 | .074 | 49 |
| 3/32 | 48 | .073 | 49 |
| 7/64 | 56 | .092 | 42 |
| 7/64 | 50 | .090 | 43 |
| 7/64 | 48 | .089 | 43 |
| 1/8 | 48 | .105 | 36 |
| 1/8 | 40 | .101 | 38 |
| 1/8 | 36 | .098 | 40 |
| 1/8 | 32 | .095 | 3/32 |
| 9/64 | 40 | .116 | 32 |
| 9/64 | 36 | .114 | 33 |
| 9/64 | 32 | .110 | 35 |
| 5/32 | 40 | .132 | 30 |
| 5/32 | 36 | .129 | 30 |
| 5/32 | 32 | .126 | 1/8 |
| 11/64 | 36 | .145 | 27 |
| 11/64 | 32 | .141 | 9/64 |
| 3/16 | 36 | .161 | 20 |
| 3/16 | 32 | .157 | 22 |
| 3/16 | 30 | .155 | 23 |
| 3/16 | 24 | .147 | 26 |
| 13/64 | 32 | .173 | 17 |
| 13/64 | 30 | .171 | 11/64 |
| 13/64 | 24 | .163 | 20 |
| 7/32 | 32 | .188 | 12 |
| 7/32 | 28 | .184 | 13 |
| 7/32 | 24 | .178 | 16 |
| 15/64 | 32 | .204 | 6 |
| 15/64 | 28 | .200 | 8 |
| 15/64 | 24 | .194 | 10 |
| 1/4 | 32 | .220 | 7/32 |

| Tap Size | Threads per Inch | Hole Diameter | Drill |
|----------|------------------|---------------|-------|
| 1/4 | 28 | .215 | 3 |
| 1/4 | 27 | .214 | 3 |
| 1/4 | 24 | .209 | 4 |
| 1/4 | 20 | .201 | 7 |
| 5/16 | 32 | .282 | 9/32 |
| 5/16 | 27 | .276 | J |
| 5/16 | 24 | .272 | I |
| 5/16 | 20 | .264 | 17/64 |
| 5/16 | 18 | .258 | F |
| 3/8 | 27 | .339 | R |
| 3/8 | 24 | .334 | Q |
| 3/8 | 20 | .326 | 21/64 |
| 3/8 | 16 | .314 | 5/16 |
| 7/16 | 27 | .401 | Y |
| 7/16 | 24 | .397 | X |
| 7/16 | 20 | .389 | 25/64 |
| 7/16 | 14 | .368 | U |
| 1/2 | 27 | .464 | 15/32 |
| 1/2 | 24 | .460 | 29/64 |
| 1/2 | 20 | .451 | 29/64 |
| 1/2 | 13 | .425 | 27/64 |
| 1/2 | 12 | .419 | 27/64 |
| 9/16 | 27 | .526 | 17/32 |
| 9/16 | 18 | .508 | 33/64 |
| 9/16 | 12 | .481 | 31/64 |
| 5/8 | 27 | .589 | 19/32 |
| 5/8 | 18 | .571 | 37/64 |
| 5/8 | 12 | .544 | 35/64 |
| 5/8 | 11 | .536 | 17/32 |
| 11/16 | 16 | .627 | 5/8 |
| 11/16 | 11 | .599 | 19/32 |
| 3/4 | 27 | .714 | 23/32 |
| 3/4 | 16 | .689 | 11/16 |
| 3/4 | 12 | .669 | 43/64 |
| 3/4 | 10 | .653 | 21/32 |
| 13/16 | 12 | .731 | 47/64 |
| 13/16 | 10 | .715 | 23/32 |
| 7/8 | 27 | .839 | 27/32 |
| 7/8 | 18 | .821 | 53/64 |
| 7/8 | 14 | .805 | 13/16 |

| Tap Size | Threads per Inch | Hole Diameter | Drill |
|----------|------------------|---------------|---------|
| 7/8 | 12 | .794 | 51/64 |
| 7/8 | 9 | .767 | 49/64 |
| 15/16 | 12 | .856 | 55/64 |
| 15/16 | 9 | .829 | 53/64 |
| 1 | 27 | .964 | 31/32 |
| 1 | 14 | .930 | 15/16 |
| 1 | 12 | .919 | 59/64 |
| 1 | 8 | .878 | 7/8 |
| 1-1/16 | 8 | .941 | 15/16 |
| 1-1/8 | 12 | 1.044 | 1-3/64 |
| 1-1/8 | 7 | .986 | 63/64 |
| 1-3/16 | 7 | 1.048 | 1-3/64 |
| 1-1/4 | 12 | 1.169 | 1-11/64 |
| 1-1/4 | 7 | 1.111 | 1-7/64 |
| 1-5/16 | 7 | 1.173 | 1-11/64 |
| 1-3/8 | 12 | 1.294 | 1-19/64 |
| 1-3/8 | 6 | 1.213 | 1-7/32 |
| 1-1/2 | 12 | 1.419 | 1-27/64 |
| 1-1/2 | 6 | 1.338 | 1-11/32 |
| 1-5/8 | 5-1/2 | 1.448 | 1-29/64 |
| 1-3/4 | 5 | 1.555 | 1-9/16 |
| 1-7/8 | 5 | 1.680 | 1-11/16 |
| 2 | 4-1/2 | 1.783 | 1-25/32 |
| 2-1/8 | 4-1/2 | 1.909 | 1-29/32 |
| 2-1/4 | 4-1/2 | 2.034 | 2-1/32 |
| 2-3/8 | 4 | 2.131 | 2-1/8 |
| 2-1/2 | 4 | 2.256 | 2-1/4 |
| 2-5/8 | 4 | 2.381 | 2-3/8 |
| 2-3/4 | 4 | 2.506 | 2-1/2 |
| 2-7/8 | 3-1/2 | 2.597 | 2-19/32 |
| 3 | 3-1/2 | 2.722 | 2-23/32 |
| 3-1/8 | 3-1/2 | 2.847 | 2-27/32 |
| 3-1/4 | 3-1/2 | 2.972 | 2-31/32 |
| 3-3/8 | 3-1/4 | 3.075 | 3-1/16 |
| 3-1/2 | 3-1/4 | 3.200 | 3-3/16 |
| 3-5/8 | 3-1/4 | 3.325 | 3-5/16 |
| 3-3/4 | 3 | 3.425 | 3-7/16 |
| 4 | 3 | 3.675 | 3-11/16 |



DOUBLE DEPTH OF SCREW THREADS

ISO EXTERNAL THREADS

MEDIUM FIT

$$D.D. = \frac{1.732}{N} \text{ For V Thread}$$

$$D.D. = \frac{1.299}{N} \text{ For American Nat. Form, U.S. Std}$$

$$D.D. = \frac{1.28}{N} \text{ For Whitworth Standard}$$

| Threads per Inch | V Threads | Am. Nat. Form U.S. Standard | Whitworth Standard |
|------------------|-----------|--------------------------------|-----------------------|
| N | D.D. | D.D. | D.D. |
| 2 | .86600 | .64950 | .64000 |
| 3 | .57733 | .43300 | .42666 |
| 4 | .43300 | .32475 | .32000 |
| 10 | .17320 | .12990 | .12800 |
| 13 | .13323 | .09992 | .09846 |
| 18 | .09622 | .07216 | .07111 |
| 20 | .08660 | .06495 | .06400 |
| 22 | .07872 | .05904 | .05818 |
| 24 | .07216 | .05412 | .05333 |
| 26 | .06661 | .04996 | .04923 |
| 27 | .06415 | .04811 | .04740 |
| 28 | .06185 | .04639 | .04571 |
| 30 | .05773 | .04330 | .04266 |
| 32 | .05412 | .04059 | .04000 |
| 34 | .05094 | .03820 | .03764 |
| 36 | .04811 | .03608 | .03555 |
| 38 | .04558 | .03418 | .03368 |
| 40 | .04330 | .03247 | .03200 |
| 56 | .03093 | .02319 | .02285 |
| 60 | .02887 | .02165 | .02133 |
| 80 | .02165 | .01623 | .01600 |

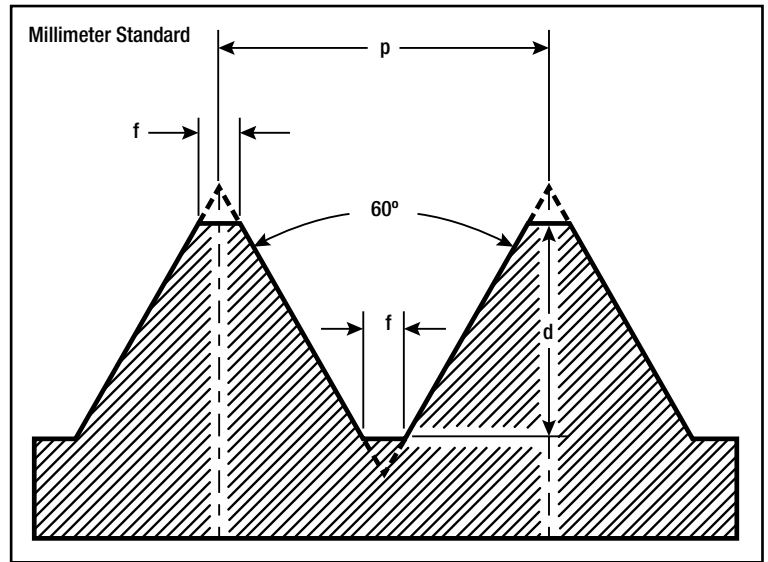

p = distance between any point on a thread to the corresponding point on the adjacent thread
 d = depth - 0.64952P
 f = flat - 0.125P

| Designation | mm Diameter | mm Pitch |
|-------------|-------------|----------|
| M2 x 0.4 | 2 | 0.4 |
| M3 x 0.5 | 3 | 0.5 |
| M4 x 0.7 | 4 | 0.7 |
| M5 x 0.8 | 5 | 0.8 |
| M6 x 1 | 6 | 1.0 |
| M8 x 1.25 | 8 | 1.25 |
| M10 x 1.5 | 10 | 1.5 |
| M12 x 1.75 | 12 | 1.75 |
| M16 x 2 | 16 | 2.0 |
| M20 x 2.5 | 20 | 2.5 |
| M24 x 3 | 24 | 3.0 |
| M30 x 3.5 | 30 | 3.5 |

THREAD TERMINOLOGY

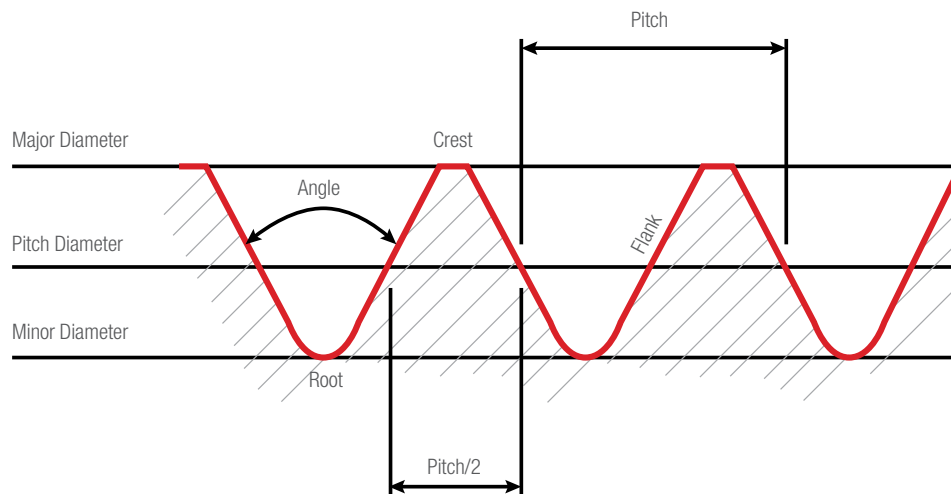

AMERICAN STANDARD ACME SCREW THREAD DIMENSIONS

h = Basic depth of thread
 h' = Depth of thread with clearance
 K = Tap drill
 Basic minor diameter of nut
 Fc = Width of flat at crest of thread
 Fr = Width of flat at bottom of space
 n = Number of threads per inch
 p = Pitch of thread
 Kr = Minor diameter of screw
 D = Major diameter of screw
 T = Major diameter of tap

FOR 10 OR FEWER THREADS PER INCH

$$h' = \frac{P}{2} \text{ plus } .010$$

$$Fr = \frac{.3707}{n} \text{ minus } .0052$$

$$T = D \text{ plus } .020$$

FOR MORE THAN 10 THREADS PER INCH

$$h' = \frac{P}{2} \text{ plus } .005$$

$$Fr = \frac{.3707}{n} \text{ minus } .0026$$

$$T = D \text{ plus } .010$$

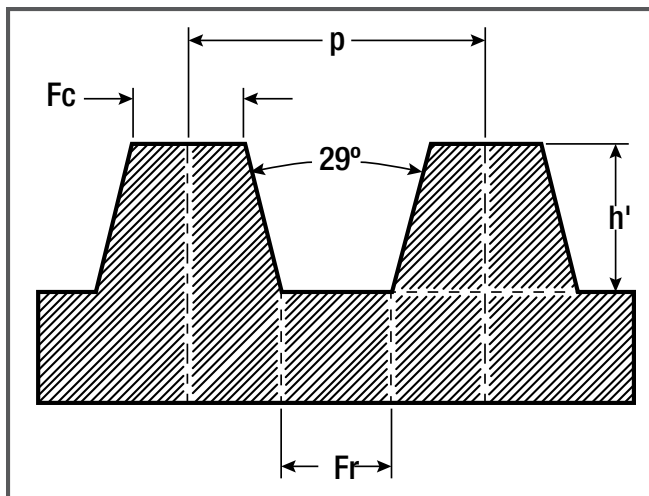

$$p = \frac{1}{n} \quad Fc = \frac{.3707}{n}$$

$$K = D \text{ minus } p \quad Kr = D \text{ minus } 2h'$$

| Threads per inch (n) | Depth of Thread with Clearance (h') | Flat at Top of Thread (Fc) | Flat at Bottom of Space (Fr) | Space at Top of Thread | Thickness at Root of Thread |
|----------------------|-------------------------------------|----------------------------|------------------------------|------------------------|-----------------------------|
| 1 | .5100 | .3707 | .3655 | .6293 | .6345 |
| 1-1/3 | .3850 | .2780 | .2728 | .4720 | .4772 |
| 2 | .2600 | .1854 | .1802 | .3146 | .3198 |
| 3 | .1767 | .1236 | .1184 | .2097 | .2149 |
| 4 | .1350 | .0927 | .0875 | .1573 | .1625 |
| 5 | .1100 | .0741 | .0689 | .1259 | .1311 |
| 6 | .0933 | .0618 | .0566 | .1049 | .1101 |
| 7 | .0814 | .0530 | .0478 | .0899 | .0951 |
| 8 | .0725 | .0463 | .0411 | .0787 | .0839 |
| 9 | .0655 | .0412 | .0360 | .0699 | .0751 |
| 10 | .0600 | .0371 | .0319 | .0629 | .0681 |
| 12 | .0467 | .0309 | .0283 | .0524 | .0550 |
| 14 | .0407 | .0265 | .0239 | .0449 | .0475 |
| 16 | .0363 | .0232 | .0206 | .0393 | .0419 |

TAPERS AND ANGLES

| Taper per Foot | Degree | Included Angle Minute | Second | Degree | Angle With Center Line Minute | Second | Taper per inch | Taper per inch from Center Line |
|----------------|--------|-----------------------|--------|--------|-------------------------------|--------|----------------|---------------------------------|
| 1/8" | 0 | 35 | 49 | 0 | 17 | 54 | .010417 | .005208 |
| 1/4" | 1 | 11 | 37 | 0 | 35 | 49 | .020833 | .010417 |
| 3/8" | 1 | 47 | 25 | 0 | 53 | 43 | .031250 | .015625 |
| 1/2" | 2 | 23 | 13 | 1 | 11 | 37 | .041667 | .020833 |
| 5/8" | 2 | 59 | 1 | 1 | 29 | 30 | .052083 | .026042 |
| 3/4" | 3 | 34 | 47 | 1 | 47 | 24 | .062500 | .031250 |
| 7/8" | 4 | 10 | 33 | 2 | 5 | 17 | .072917 | .036458 |
| 1" | 4 | 46 | 19 | 2 | 23 | 9 | .083333 | .041667 |
| 1-1/4" | 5 | 57 | 47 | 2 | 58 | 53 | .104167 | .052084 |
| 1-1/2" | 7 | 9 | 10 | 3 | 34 | 35 | .125000 | .062500 |
| 1-3/4" | 8 | 20 | 27 | 4 | 10 | 14 | .145833 | .072917 |
| 2" | 9 | 31 | 38 | 4 | 45 | 49 | .166667 | .083333 |
| 2-1/2" | 11 | 53 | 37 | 5 | 56 | 49 | .208333 | .104167 |
| 3" | 14 | 2 | 0 | 7 | 1 | 30 | .250000 | .125000 |
| 3-1/2" | 16 | 35 | 39 | 8 | 17 | 50 | .291667 | .145833 |
| 4" | 18 | 55 | 29 | 9 | 27 | 44 | .333333 | .166667 |
| 4-1/2" | 21 | 14 | 22 | 10 | 37 | 11 | .375000 | .187500 |
| 5" | 23 | 32 | 12 | 11 | 46 | 6 | .416667 | .208333 |
| 6" | 28 | 4 | 21 | 14 | 2 | 10 | .500000 | .250000 |



PITCH DIAMETER TABLES – AMERICAN NATIONAL THREAD FORM

FOR NOS. 575 AND 585 SCREW THREAD MICROMETERS

Number Sizes

$$\text{Caliper Reading or Pitch Diameter} = D - \frac{.6495}{N}$$

Fractional Sizes

$$\text{Caliper Reading or Pitch Diameter} = D - \frac{.6495}{N}$$

| No. | Basic and Max. Outside Diameter | Threads Per Inch | Caliper Reading or Max. Pitch Diameter | Single Depth of Thread |
|-----|---------------------------------|------------------|--|------------------------|
| | D | N | D - $\frac{.6495}{N}$ | $\frac{.6495}{N}$ |
| 0 | .060 | 80 | .0519 | .0081 |
| 1 | .073 | 72 | .0640 | .0090 |
| 2 | .086 | 64 | .0759 | .0101 |
| 3 | .099 | 56 | .0874 | .0116 |
| 4 | .112 | 48 | .0985 | .0135 |
| 5 | .125 | 44 | .1102 | .0148 |
| 6 | .138 | 40 | .1218 | .0162 |
| 7 | .151 | 36 | .1330 | .0180 |
| 8 | .164 | 36 | .1460 | .0180 |
| 9 | .177 | 32 | .1567 | .0203 |
| 10 | .190 | 30 | .1684 | .0217 |
| 12 | .216 | 28 | .1928 | .0232 |
| 14 | .242 | 24 | .2149 | .0271 |
| 16 | .268 | 22 | .2385 | .0295 |
| 18 | .294 | 20 | .2615 | .0325 |
| 20 | .320 | 20 | .2875 | .0325 |
| 22 | .346 | 18 | .3099 | .0361 |
| 24 | .372 | 16 | .3314 | .0406 |
| 26 | .398 | 16 | .3574 | .0406 |
| 28 | .424 | 14 | .3776 | .0464 |
| 30 | .450 | 14 | .4036 | .0464 |

| Diameter (in) | Threads Per Inch | Caliper Reading of Pitch Diameter | Single Depth of Thread |
|---|------------------|-----------------------------------|------------------------|
| D | N | D - $\frac{.6495}{N}$ | $\frac{.6495}{N}$ |
| Note: As there is no standard of diameter for the finer pitches, this column is left blank. | 64 | — | .0101 |
| | 62 | — | .0105 |
| | 60 | — | .0108 |
| | 58 | — | .0112 |
| | 56 | — | .0116 |
| | 54 | — | .0120 |
| | 52 | — | .0125 |
| | 50 | — | .0130 |
| | 48 | — | .0135 |
| | 46 | — | .0141 |
| | 44 | — | .0148 |
| | 42 | — | .0155 |
| | 40 | — | .0162 |
| | 38 | — | .0171 |
| | 36 | — | .0180 |
| | 34 | — | .0191 |
| | 32 | — | .0203 |
| | 30 | — | .0217 |
| 28 | — | .0232 | |
| 26 | — | .0250 | |
| 24 | — | .0271 | |
| 22 | — | .0295 | |
| 1/4 | 20 | .2175 | .0325 |
| 5/16 | 18 | .2764 | .0361 |
| 3/8 | 16 | .3344 | .0406 |
| 7/16 | 14 | .3911 | .0464 |
| 1/2 | 13 | .4501 | .0499 |
| 9/16 | 12 | .5084 | .0541 |
| 5/8 | 11 | .5660 | .0590 |
| 3/4 | 10 | .6851 | .0649 |
| 7/8 | 9 | .8029 | .0721 |
| 1 | 8 | .9188 | .0812 |
| 1-1/8 | 7 | 1.0322 | .0928 |
| 1-1/4 | 7 | 1.1572 | .0928 |
| 1-3/8 | 6 | 1.2668 | .1082 |
| 1-1/2 | 6 | 1.3918 | .1082 |
| 1-5/8 | 5-1/2 | 1.5070 | .1180 |
| 1-3/4 | 5 | 1.6201 | .1299 |
| 1-7/8 | 5 | 1.7451 | .1299 |
| 2 | 4-1/2 | 1.8557 | .1443 |
| 2-1/2 | 4 | 2.3376 | .1624 |
| 3 | 3-1/2 | 2.8145 | .1855 |
| 3-1/2 | 3-1/4 | 3.3002 | .1998 |
| 4 | 3 | 3.7835 | .2165 |



PITCH DIAMETER TABLES

FOR NOS. 575 AND 585 SCREWTHREAD MICROMETERS

Whitworth Standard

$$\text{Caliper Reading or Pitch Diameter for Whitworth Threads} = D - \frac{.640}{N}$$

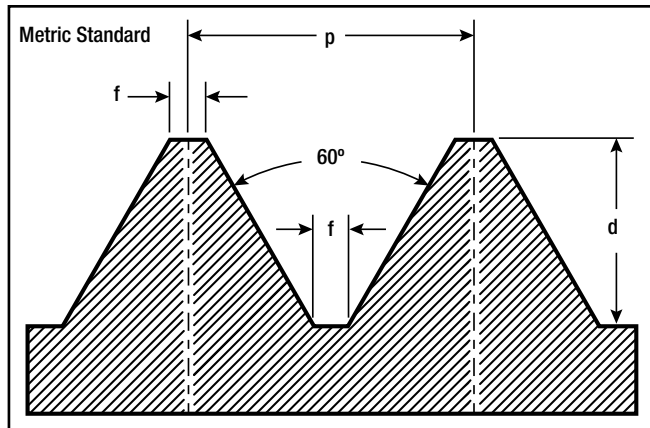

$$p = \text{pitch} = \frac{1}{\text{No. thread per inch}}$$

$$d = \text{depth} = p \times .6495$$

$$f = \text{flat} = \frac{\text{pitch}}{8}$$

| Diameter (in) | Threads per Inch | Caliper Reading or Pitch Diameter | Single Depth of Thread |
|---------------|------------------|-----------------------------------|------------------------|
| D | N | D - $\frac{.640}{N}$ | $\frac{.640}{N}$ |
| — | 48 | — | .0133 |
| — | 46 | — | .0139 |
| — | 44 | — | .0146 |
| — | 42 | — | .0152 |
| — | 40 | — | .0160 |
| — | 38 | — | .0168 |
| — | 36 | — | .0178 |
| — | 34 | — | .0188 |
| — | 32 | — | .0200 |
| — | 30 | — | .0213 |
| — | 28 | — | .0229 |
| — | 26 | — | .0246 |
| — | 24 | — | .0267 |
| — | 22 | — | .0291 |
| 1/4 | 20 | .2180 | .0320 |
| 5/16 | 18 | .2769 | .0355 |
| 3/8 | 16 | .3350 | .0400 |
| 7/16 | 14 | .3918 | .0457 |
| 1/2 | 12 | .4467 | .0533 |
| 9/16 | 12 | .5092 | .0533 |
| 5/8 | 11 | .5668 | .0582 |
| 11/16 | 11 | .6293 | .0582 |
| 3/4 | 10 | .6860 | .0640 |
| 13/16 | 10 | .7485 | .0640 |
| 7/8 | 9 | .8039 | .0711 |
| 15/16 | 9 | .8664 | .0711 |
| 1 | 8 | .9200 | .0800 |
| 1-1/8 | 7 | 1.0336 | .0914 |
| 1-1/4 | 7 | 1.1586 | .0914 |
| 1-3/8 | 6 | 1.2684 | .1066 |
| 1-1/2 | 6 | 1.3934 | .1066 |
| 1-5/8 | 5 | 1.4970 | .1280 |
| 1-3/4 | 5 | 1.6220 | .1280 |
| 1-7/8 | 4-1/2 | 1.7328 | .1422 |
| 2 | 4-1/2 | 1.8578 | .1422 |
| 2-1/8 | 4-1/2 | 1.9828 | .1422 |

| Size (mm) | Pitch Intl. Std. | French Std. |
|-----------|------------------|-------------|
| 2 | .45 | .50 |
| 3 | .55 | .50 |
| 4 | .70 | .75 |
| 5 | .85 | .75 |
| 6 | 1.00 | 1.00 |
| 7 | 1.00 | 1.00 |
| 8 | 1.25 | 1.00 |
| 9 | 1.25 | 1.00 |
| 10 | 1.50 | 1.50 |
| 11 | 1.50 | — |
| 12 | 1.75 | 1.50 |
| 14 | 2.00 | 2.00 |
| 16 | 2.00 | 2.00 |
| 18 | 2.50 | 2.50 |
| 20 | 2.50 | 2.50 |
| 22 | 2.50 | 2.50 |
| 24 | 3.00 | 3.00 |
| 26 | — | 3.00 |
| 27 | 3.00 | — |
| 28 | — | 3.00 |
| 30 | 3.50 | 3.50 |
| 32 | — | 3.50 |
| 33 | 3.50 | 3.50 |
| 34 | — | 3.50 |
| 36 | 4.00 | 4.00 |
| 38 | — | 4.00 |
| 39 | 4.00 | — |
| 40 | — | 4.00 |



PITCH DIAMETER TABLE

FOR NOS. 575 AND 585 SCREW THREAD MICROMETERS "V" STANDARD THREAD FORM

Caliper Reading or Pitch Diameter for "V" Threads = $D - \frac{.866}{N}$

| Diameter (in) | Threads per Inch | Caliper Reading or Pitch Diameter | | | Single Depth of Thread | Diameter (in)* | Threads per Inch | Caliper Reading or Pitch Diameter | | | Single Depth of Thread |
|---|------------------|-----------------------------------|------|-------|------------------------|----------------|------------------|-----------------------------------|-------|------|------------------------|
| | | D - | .866 | .866 | | | | D - | .866 | .866 | |
| D | N | | N | N | D | N | | N | N | D | N |
| Note: As there is no standard of diameter for the finer pitches, this column is left blank. | 64 | — | | .0135 | 1/4 | 24 | .2139 | | .0361 | | |
| | 62 | — | | .0140 | 1/4 | 20 | .2067 | | .0433 | | |
| | 60 | — | | .0144 | 5/16 | 20 | .2692 | | .0433 | | |
| | 58 | — | | .0149 | 5/16 | 18 | .2644 | | .0481 | | |
| | 56 | — | | .0155 | 3/8 | 18 | .3269 | | .0481 | | |
| | 54 | — | | .0161 | 3/8 | 16 | .3209 | | .0541 | | |
| | 52 | — | | .0167 | 7/16 | 16 | .3834 | | .0541 | | |
| | 50 | — | | .0173 | 7/16 | 14 | .3756 | | .0619 | | |
| | 48 | — | | .0180 | 1/2 | 14 | .4381 | | .0619 | | |
| | 46 | — | | .0188 | 1/2 | 13 | .4334 | | .0666 | | |
| | 44 | — | | .0197 | 1/2 | 12 | .4278 | | .0722 | | |
| | 42 | — | | .0206 | 9/16 | 14 | .5006 | | .0619 | | |
| | 40 | — | | .0217 | 9/16 | 12 | .4903 | | .0722 | | |
| | 38 | — | | .0228 | 5/8 | 11 | .5463 | | .0787 | | |
| | 36 | — | | .0241 | 5/8 | 10 | .5384 | | .0866 | | |
| | 34 | — | | .0255 | 11/16 | 10 | .6009 | | .0866 | | |
| | 32 | — | | .0271 | 3/4 | 10 | .6634 | | .0866 | | |
| | 30 | — | | .0289 | 7/8 | 9 | .7788 | | .0962 | | |
| | 28 | — | | .0309 | 1 | 8 | .8918 | | .1082 | | |
| | 26 | — | | .0333 | 1-1/8 | 8 | 1.0168 | | .1082 | | |
| — | — | | — | 1-1/4 | 7 | 1.1263 | | .1237 | | | |
| — | — | | — | 1-1/2 | 6 | 1.3557 | | .1443 | | | |

* These figures give the outside diameter for screws with threads cut theoretically sharp. As it is not practical to make these threads sharp, the outside diameter will measure less than the figures given, the pitch diameter remaining the same.

AMERICAN STANDARD ACME SCREW THREAD DIMENSIONS

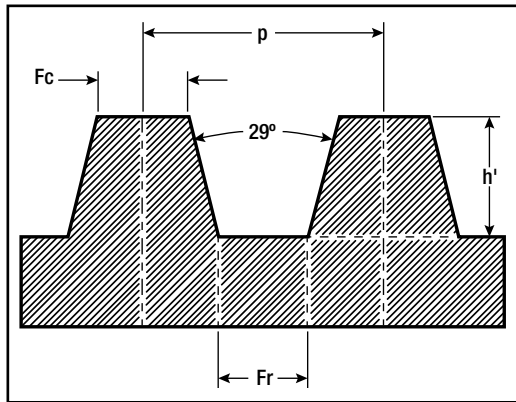

- h = Basic depth of thread
- h' = Depth of thread with clearance
- K = Tap drill
- Basic minor diameter of nut
- Fc = Width of flat at crest of thread
- Fr = Width of flat at bottom of space
- n = Number of threads per inch
- p = Pitch of thread
- Kr = Minor diameter of screw
- D = Major diameter of screw
- T = Major diameter of tap

| Threads per inch (n) | Depth of Thread with Clearance (h') | Flat at Top of Thread (Fc) | Flat at Bottom of Space (Fr) | Space at Top of Thread | Thickness at Root of Thread |
|----------------------|-------------------------------------|----------------------------|------------------------------|------------------------|-----------------------------|
| 1 | .5100 | .3707 | .3655 | .6293 | .6345 |
| 1-1/3 | .3850 | .2780 | .2728 | .4720 | .4772 |
| 2 | .2600 | .1854 | .1802 | .3146 | .3198 |
| 3 | .1767 | .1236 | .1184 | .2097 | .2149 |
| 4 | .1350 | .0927 | .0875 | .1573 | .1625 |
| 5 | .1100 | .0741 | .0689 | .1259 | .1311 |
| 6 | .0933 | .0618 | .0566 | .1049 | .1101 |
| 7 | .0814 | .0530 | .0478 | .0899 | .0951 |
| 8 | .0725 | .0463 | .0411 | .0787 | .0839 |
| 9 | .0655 | .0412 | .0360 | .0699 | .0751 |
| 10 | .0600 | .0371 | .0319 | .0629 | .0681 |
| 12 | .0467 | .0309 | .0283 | .0524 | .0550 |
| 14 | .0407 | .0265 | .0239 | .0449 | .0475 |
| 16 | .0363 | .0232 | .0206 | .0393 | .0419 |

$p = \frac{1}{n}$ $F_c = \frac{.3707}{n}$
 K = minus p Kr = D minus 2h'

FOR 10 OR FEWER THREADS PER INCH

$h' = \frac{P}{2}$ plus .010
 $F_r = \frac{.3707}{n}$ minus .0052
 T = D plus .020

FOR MORE THAN 10 THREADS PER INCH

$h' = \frac{P}{2}$ plus .005
 $F_r = \frac{.3707}{n}$ minus .0026
 T = D plus .010



GENERAL GUIDE FOR CUTTING SPEEDS AND FEEDS FOR DRILLS

The following information is a general guide. Specific jobs may need to be modified because of varying job conditions, such as coolant, equipment and job requirements.

GUIDE FOR DRILL FEEDS

Drill feeds are governed by the size of the drill and also the material to be drilled.

The lower feeds should be used when drilling relatively hard materials such as alloy steels. The higher feeds should be used when drilling relatively soft materials such as aluminum and brass.

These feeds are based on the peripheral speed of a drill.

| Drill Dia. | Feed per Rev. | Drill Dia. | Feed per Rev. |
|-------------|---------------|------------|---------------|
| Under 1/80 | .0010 - .0020 | Under 3mm | .025 - .05mm |
| 1/80 - 1/40 | .0020 - .0040 | 3 - 6mm | .05 - .100mm |
| 1/40 - 1/20 | .0040 - .0070 | 6 - 13mm | .100 - .180mm |
| 1/20 - 10 | .0070 - .0150 | 13 - 25mm | .180 - .370mm |
| Over 10 | .0150 - .0250 | Over 25mm | .370 - .630mm |

GUIDE FOR PERIPHERAL SPEEDS

| Material | Feet/Minute | | Meters/Minute | |
|-----------------|--------------|-----------|---------------|-----------|
| | Carbon Drill | HSS Drill | Carbon Drill | HSS Drill |
| Machinery Steel | 30 | 80 | 9 | 24 |
| Cast Iron | 35 | 100 | 10.5 | 30 |
| Brass | 60 | 200 | 18 | 60 |
| Alloy Steel | – | 50 | – | 15 |

| Drill Diameter | | Peripheral Speeds – Feet per Minute (Meters per Minute) | | | | | |
|----------------|----|---|---------|---------|---------|----------|----------|
| | | Revolutions per Minute | | | | | |
| in | mm | 30 (9) | 50 (15) | 60 (18) | 80 (24) | 100 (30) | 200 (60) |
| 1/8 | 3 | 917 | 1528 | 1833 | 2445 | 3056 | 6112 |
| 1/4 | 6 | 458 | 764 | 917 | 1222 | 1528 | 3056 |
| 1/2 | 13 | 229 | 382 | 458 | 611 | 764 | 1528 |
| 1 | 25 | 115 | 191 | 229 | 306 | 382 | 764 |
| 1-1/2 | 38 | 76 | 127 | 153 | 204 | 255 | 509 |
| 2 | 50 | 57 | 96 | 115 | 153 | 191 | 382 |
| 3 | 75 | 38 | 64 | 76 | 102 | 127 | 255 |



STANDARDS FOR SHEET AND WIRE GAGES WITH CORRESPONDING STARRETT GAGES

Dimensions of Sizes in Decimal Parts of an Inch

| Number of Wire Gage | 281 American or Brown & Sharpe | 188 245 Birmingham or Stubs' Iron Wire | 287 Washburn & Moen, Worcester, MA | 280 American S. & W. Co's. Music Wire Gage | Stubs' Steel Wire | 283 U.S. Standard Gage for Sheet and Plate Iron and Steel |
|---------------------|--------------------------------|--|------------------------------------|--|-------------------|---|
| 00000000 | .731429 | | | | | |
| 0000000 | .651356 | | | | | |
| 000000 | .580049 | | | .004 | | .46875 |
| 00000 | .516549 | | | .005 | | .4375 |
| 0000 | .460000 | .454 | .3938 | .006 | | .40625 |
| 000 | .409642 | .425 | .3625 | .007 | | .375 |
| 00 | .364797 | .380 | .3310 | .008 | | .34375 |
| 0 | .324861 | .340 | .3065 | .009 | | .3125 |
| 1 | .289279 | .300 | .2830 | .010 | .227 | .28125 |
| 2 | .257626 | .284 | .2625 | .011 | .219 | .265625 |
| 3 | .229423 | .259 | .2437 | .012 | .212 | .250 |
| 4 | .204307 | .238 | .2253 | .013 | .207 | .234375 |
| 5 | .181941 | .220 | .2070 | .014 | .204 | .21875 |
| 6 | .162023 | .203 | .1920 | .016 | .201 | .203125 |
| 7 | .144285 | .180 | .1770 | .018 | .199 | .1875 |
| 8 | .128490 | .165 | .1620 | .020 | .197 | .171875 |
| 9 | .114424 | .148 | .1483 | .022 | .194 | .15625 |
| 10 | .101897 | .134 | .1350 | .024 | .191 | .140625 |
| 11 | .090742 | .120 | .1205 | .026 | .188 | .125 |
| 12 | .080808 | .109 | .1055 | .029 | .185 | .109375 |
| 13 | .071962 | .095 | .0915 | .031 | .182 | .09375 |
| 14 | .064084 | .083 | .0800 | .033 | .180 | .078125 |
| 15 | .057068 | .072 | .0720 | .035 | .178 | .0703125 |
| 16 | .050821 | .065 | .0625 | .037 | .175 | .0625 |
| 17 | .045257 | .058 | .0540 | .039 | .172 | .05625 |
| 18 | .040303 | .049 | .0475 | .041 | .168 | .050 |
| 19 | .035891 | .042 | .0410 | .043 | .164 | .04375 |
| 20 | .031961 | .035 | .0348 | .045 | .161 | .0375 |
| 21 | .028462 | .032 | .03175 | .047 | .157 | .034375 |
| 22 | .025347 | .028 | .0286 | .049 | .155 | .03125 |
| 23 | .022572 | .025 | .0258 | .051 | .153 | .028125 |
| 24 | .020101 | .022 | .0230 | .055 | .151 | .025 |
| 25 | .017900 | .020 | .0204 | .059 | .148 | .021875 |
| 26 | .015941 | .018 | .0181 | .063 | .146 | .01875 |
| 27 | .014196 | .016 | .0173 | .067 | .143 | .0171875 |
| 28 | .012641 | .014 | .0162 | .071 | .139 | .015625 |
| 29 | .011258 | .013 | .0150 | .075 | .134 | .0140625 |
| 30 | .010025 | .012 | .0140 | .080 | .127 | .0125 |
| 31 | .008928 | .010 | .0132 | .085 | .120 | .0109375 |
| 32 | .007950 | .009 | .0128 | .090 | .115 | .01015625 |
| 33 | .007080 | .008 | .0118 | .095 | .112 | .009375 |
| 34 | .006305 | .007 | .0104 | | .110 | .00859375 |
| 35 | .005615 | .005 | .0095 | | .108 | .0078125 |
| 36 | .005000 | .004 | .0090 | | .106 | .00703125 |
| 37 | .004453 | | | | .103 | .006640625 |
| 38 | .003965 | | | | .101 | .00625 |
| 39 | .003531 | | | | .099 | |
| 40 | .003145 | | | | .097 | |



TEMPERATURE CONVERSIONS

This table shows conversions from degrees Fahrenheit (°F) directly to degrees Celsius (°C) and vice versa. It covers the range of temperatures used in most hardening, tempering and annealing operations.

Lower, higher and intermediate conversions can be made by substituting a known Fahrenheit (°F) or Celsius (°C) temperature figure in either of the following formulas:

$$^{\circ}\text{F} = \frac{^{\circ}\text{C} \times 9}{5} + 32 \qquad ^{\circ}\text{C} = \frac{^{\circ}\text{F} - 32}{9} \times 5$$

| °F | °C |
|------|------|
| -160 | -107 |
| -140 | -96 |
| -120 | -84 |
| -100 | -73 |
| -80 | -62 |
| -60 | -51 |
| -40 | -40 |
| -20 | -29 |
| 0 | -18 |
| 20 | -7 |
| 32 | 0 |
| 40 | 4 |
| 60 | 16 |
| 80 | 27 |
| 100 | 38 |
| 120 | 49 |
| 140 | 60 |
| 160 | 71 |

| °F | °C |
|------|------|
| 180 | 82 |
| 200 | 93 |
| 212 | 100 |
| 220 | 104 |
| 300 | 149 |
| 400 | 204 |
| 500 | 260 |
| 600 | 316 |
| 700 | 371 |
| 800 | 427 |
| 1000 | 538 |
| 1200 | 649 |
| 1400 | 760 |
| 1600 | 871 |
| 1800 | 982 |
| 2000 | 1093 |
| 2200 | 1204 |

HIGH TEMPERATURES JUDGED BY COLOR

| Degrees Centigrade | Degrees Fahrenheit | High Temperatures Judged by Color |
|--------------------|--------------------|-----------------------------------|
| 400 | 752 | Red heat, visible in the dark |
| 525 | 975 | Red heat, visible in daylight |
| 700 | 1292 | Dark red |
| 900 | 1652 | Cherry-red |
| 1100 | 2012 | Orange-red |
| 1300 | 2372 | Yellow-white |
| 1500 | 2732 | Brilliant white |

COLORS FOR TEMPERING

| Degrees Centigrade | Degrees Fahrenheit | Colors for Tempering |
|--------------------|--------------------|----------------------|
| 221.1 | 430 | Very pale yellow |
| 237.8 | 460 | Straw-yellow |
| 254.4 | 490 | Yellow-brown |
| 260.0 | 500 | Brown-yellow |
| 271.1 | 520 | Brown-purple |
| 282.2 | 540 | Full purple |
| 293.3 | 560 | Full blue |

RULES RELATIVE TO THE CIRCLE

TO FIND CIRCUMFERENCE

- Multiply diameter by 3.1416
- Or divide diameter by 0.3183

TO FIND DIAMETER

- Multiply circumference by 0.3183
- Or divide circumference by 3.1416

TO FIND RADIUS

- Multiply circumference by 0.15915
- Or divide circumference by 6.28318

TO FIND SIDE OF AN INSCRIBED SQUARE

- Multiply diameter by 0.7071
- Or multiply circumference by 0.2251
- Or divide circumference by 4.4428

TO FIND SIDE OF AN EQUAL SQUARE

- Multiply diameter by 0.8862
- Or divide diameter by 1.1284
- Or multiply circumference by 0.2821
- Or divide circumference by 3.545

SQUARE

- A side multiplied by 1.4142 equals diameter of its circumscribing circle
- A side multiplied by 4.443 equals circumference of its circumscribing circle
- A side multiplied by 1.128 equals diameter of an equal side
- A side multiplied by 3.547 equals circumference of an equal circle

TO FIND THE AREA OF A CIRCLE

- Multiply circumference by one-quarter of the diameter
- Or multiply the square of diameter by 0.7854
- Or multiply the square of circumference by .07958
- Or multiply the square of 1/2 diameter by 3.1416

TO FIND THE SURFACE OF A SPHERE OR GLOBE

- Multiply the diameter by the circumference
- Or multiply the square of a diameter by 3.1416
- Or multiply four times the square of radius by 3.1416



TRIANGLE CHART

FOR THE RAPID SOLUTION OF RIGHT-ANGLE AND OBLIQUE-ANGLE TRIANGLES

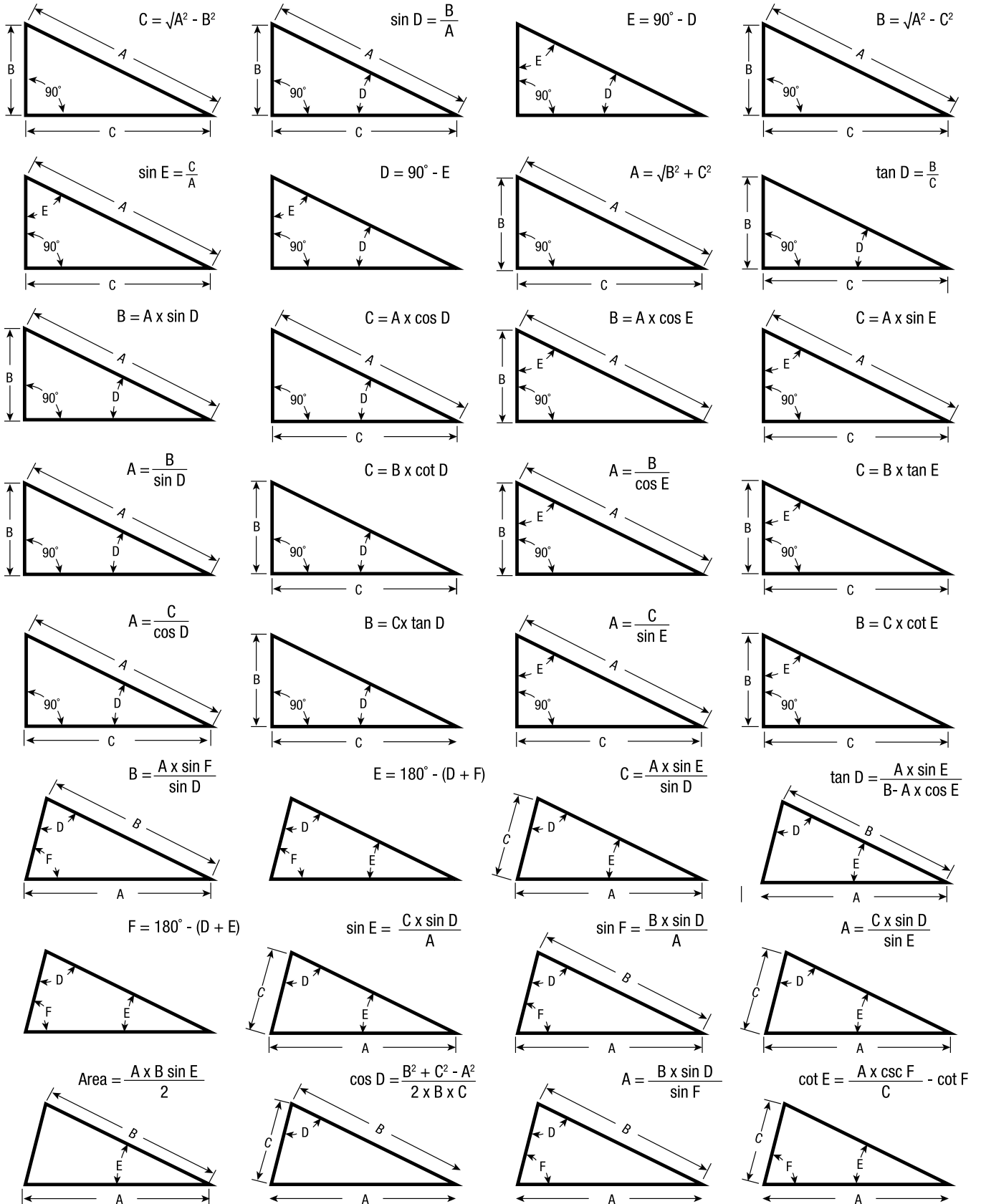



INDEX

A

Amplifiers

| | |
|-----------------|-----|
| Electronic Gage | |
| Gage-Chek™ | 234 |

B

Blocks

| | |
|-----------------|-----|
| Bench | 348 |
| Gage | 391 |
| Inspection | 366 |
| Reverse Reading | 119 |
| Riser | 119 |
| Wear Blocks | 383 |

Bore Gages 203–214

| | |
|-------------------------|---------|
| AccuPlug | 216–219 |
| Dial | 213–215 |
| Electronic | 204–208 |
| AccuBore® | 204–206 |
| Special Measuring Heads | 212 |
| Vernier | 209 |

C

Calibration, Accuracy/General Service Information 14–16

Calipers

| | |
|---------------------------------|---------|
| Firm-Joint | 313–314 |
| Hermaphrodite | 313–314 |
| Leg Type | |
| Spring-Type, Round Legs | 312 |
| Spring-Type, "Yankee" Flat Legs | 312 |
| Lock-Joint | 313–314 |

Slide Calipers

| | |
|----------------------------|-----------|
| Carbon Fiber | 92 |
| Center Distance Attachment | 99 |
| Circumference | 105 |
| Dial | 96, 98–99 |
| Electronic | 91 |
| Groove | 95 |
| Long Jaw | 94 |
| Pocket | 105 |
| Vernier | 100–104 |
| Gear Tooth | 104 |

| | |
|-------------|-----|
| Master | 100 |
| Spring-Type | 312 |
| "Yankee" | 312 |

Trammels 315–316

Center Finder/Wiggler 346

Clamps

| | |
|----------------------|-----|
| Shaft Alignment | 194 |
| Toolmakers' Parallel | 356 |
| Toolmakers' Steel | 357 |

Collet Adaptor 137, 139, 347

Combination Squares 267–279

| | |
|---|---------|
| Attachments | 274 |
| Blades | 272 |
| Heads | 273 |
| Junior | 276 |
| Large | 275 |
| Student | 275 |
| with Square & Center Heads | 269–270 |
| with Square, Center & Non-reversible Protractor Heads | 271 |

Cut Nippers 345

D

Data Collection Systems 223–230

| | |
|----------------------------|--------------|
| DataSure® Wireless Systems | 224–228 |
| GageMux | 229 |
| SmartCables | 230 |
| Software | |
| Wedge™ | 229–230, 232 |

Depth Gages 123–131

| | |
|-----------------------------|--------------|
| Attachment for Height Gages | 119 |
| Bases | 131–132 |
| Depth and Angle | 129 |
| Dial | 127, 130–132 |
| Electronic | 124–126 |
| Protractor | 309 |
| Steel Rule | 128 |
| Vernier | 128 |

Dividers

| | |
|-------------|-----|
| Toolmakers' | 312 |
| Yankee | 312 |



Drill Rod.....565–569

E

Educational Materials.....571–574

G

Gage Amplifiers, Hardness & Surface Testers.....231–249

Electronic Gage 232–236

Hardness & Surface Testers..... 237–246

Thickness Gages 248–249

Gages

Acme Screw Thread..... 329

Angle..... 129

Angle and Depth..... 129

Center 331

Chamfer..... 185

Combination Taper, Wire, Thickness 339

Comparator Stands..... 184

Countersink..... 186

Crankshaft Distortion Dial/Strain 195

Cylinder 196

Dial

Comparator 184

Diameter 198–200

Groove..... 192

Inside 193

Inside Caliper 193

Outside Caliper 193

Pocket..... 189

Sheet 187

Snap 191

Thickness 190

Universal Back-Plunger..... 142

Diameter

Set Master..... 201–202

Diameter Gages and Masters 197–202

Drill

Drill & Steel Wire..... 327–328

Jobbers' 327

Letter Size 327

Tap & Drill..... 327

Electronic

Amplifier..... 236

Snap 189

Engineers' Combination 339

Fixed Gage Standards 325–340

Angle 331

Holder..... 334

Hole..... 187, 320–323

Piano Tuners' 328

Radius 330

Scratch 344

Screw Pitch..... 332–333

Sets

Radius..... 334

Steel Pin..... 326

Surface 342–343

Surface, Universal Snugs..... 343

Taper 323

Telescoping..... 321–322

Thickness 336–340

"Feeler" Stock..... 337–339

U.S. Standard 328

Wire 328

American Standard..... 328

American Steel & Wire Co..... 328

English Standard 328

Ground Flat Stock.....552–564

Air Hardening 556–560

High Carbon 561–562

Low Carbon..... 563–564

Oil Hardening 552–555

H

Hammer, Toolmakers' 348

Height Gages 107–121

Accessories..... 119–121

Altissimo® 108–110

Dial..... 116

DIGI-CHEK™ 118

DIGI-CHEK™ II..... 117

Electronic..... 108–112

Scribers 121

Transfer Gage..... 120



| | |
|------------------------|------------|
| Vernier..... | 113–115 |
| Master..... | 114 |
| Hold-Downs..... | 356 |

I

Indicators..... 133–202

| | |
|----------------------------------|------------------------|
| Attachments and Accessories..... | 137, 139, 143, 164–167 |
| Backs..... | 163 |
| Bases/Holders..... | 175–184 |
| Contact Points..... | 165–166 |
| Design Features..... | 145 |
| Dial | |
| AGD..... | 148 |
| Accessories..... | 167–168 |
| Comparison Chart..... | 148–149 |
| General Information..... | 144–145 |
| Group 1..... | 153–154 |
| Group 2..... | 155–156 |
| Group 3..... | 156 |
| Group 4..... | 157, 160 |
| Sets..... | 156 |
| Specifications..... | 144 |
| Back Plunger..... | 141–143 |
| Comparator..... | 162, 184 |
| Long Range..... | 158–160 |
| Miniature..... | 146 |
| Nonshock Mechanism..... | 164 |
| Numbering and Line Styles..... | 150–153 |
| Shock Absorbing Anvil Unit..... | 165 |
| Special Function..... | 185–200 |
| Spindle Squares..... | 188 |
| Dial Test..... | 135–140 |
| Dovetail Mount..... | 135–136 |
| Last Word®..... | 138 |
| Swivel Head..... | 136 |
| Electronic..... | 170–174 |
| AGD Group 2..... | 170, 174 |
| Wisdom®..... | 172 |
| Holders..... | 175–184, 176 |
| Flex-O-Post..... | 179 |
| Inspection..... | 183 |
| Magnetic..... | 177–178, 180 |
| Heavy-Duty..... | 181 |

| | |
|--------------|-----|
| Mini..... | 181 |
| Testers..... | 169 |

J

Jack Screws..... 347

K

Kleenscribe™ Layout Dye..... 345

L

Laser Measurement..... 527–548

| | |
|--|-----|
| Profile360™ | |
| Apex Extrusion..... | 543 |
| Auto Seals..... | 530 |
| Extruded Window Profiles..... | 531 |
| Industrial Mobility Package..... | 536 |
| Pipe, OD, Out of Round and Length Measurement..... | 534 |
| Roll Forming..... | 533 |
| Software..... | 537 |
| Technical Specifications..... | 536 |
| Wire and Cable..... | 535 |
| Wood-Plastic Composite..... | 532 |
| Tire Industry | |
| Bead-to-Bead..... | 548 |
| GEO-360..... | 545 |
| Green Tire Uniformity System..... | 546 |
| Off-Line Profilometer..... | 541 |
| Off-Line Profilometer 3D..... | 540 |
| Off-Line Profilometer SL..... | 542 |
| On-Line Profilometer..... | 539 |
| Tire360..... | 544 |
| Tread Wear Measurement System..... | 547 |

Layout Dye..... 345

Levels

| | |
|--------------------------------------|----------|
| Machinists'..... | 370–374 |
| Bench..... | 372, 374 |
| Cross Test..... | 373 |
| Master Precision..... | 370 |
| Pocket..... | 374 |
| with ground and graduated vials..... | 371 |

Lubricant..... 364

| | |
|----------------------------|---------|
| M1® All-Purpose..... | 364–365 |
| Tool & Instrument Oil..... | 366 |



M

Machinists' Precision Shop Tools 341–366

Material Test and Force Measurement..... 481–526

| | |
|------------------------|---------|
| Accessories..... | 514–515 |
| Applications | 522–525 |
| Automation | 498–499 |
| Load Cell Sensors..... | 512–513 |
| Services..... | 526 |
| Systems..... | 482–497 |
| Test Frames | 508–510 |

Metrology Equipment

| | |
|--|---------|
| Optical Comparators | 449–474 |
| Horizontal Bench Optical Comparator..... | 450–453 |
| Horizontal Floor Optical Comparators..... | 462–464 |
| Horizontal Floor Standing Optical Comparator..... | 462–465 |
| Side Bed Optical Comparators..... | 466–469 |
| Vertical Bench Optical Comparators..... | 456–459 |
| Vertical Floor Standing Optical Comparator | 460–461 |
| OV2™ Optical Comparator Video Adaptor..... | 470 |
| Software | |
| MetLogix™ | 476–477 |
| Quadra-Chek® | 478–479 |
| TOV2 Optical Comparator Telecentric Video Adapter..... | 471 |
| Video Inspection Systems..... | 445–447 |
| KineMic™ (KMR) | 446–447 |
| Vision Systems | 423–444 |
| Automatic Vision Metrology Systems | 428–435 |
| Horizontal Digital Video Projector | 438–441 |
| Large Format Premier (LF) | 436 |
| Manual Vision Metrology Systems | 424–427 |

Micrometers 19–87, 204, 260, 573

| | |
|----------------------|-------|
| Attachments | |
| Ball | 57 |
| Bench | 74–75 |
| Calipers | |
| Inside | 82 |
| Depth | 83–87 |
| Digital Outside..... | 27–28 |
| Electronic..... | 25–26 |
| Bench..... | 74 |
| Blade-Type | 52 |

| | |
|---|--------------|
| Disc-Type | 54 |
| Multi-Anvil | 44 |
| Outside..... | 24–26 |
| Rounded Anvil | 56 |
| Screw Thread Comparator | 59 |
| Sheet Metal | 46 |
| Tube..... | 47 |
| Heads | 63–72 |
| 0-1"/0-25mm..... | 68 |
| 0-1"/0-25mm, Heavy Duty | 70 |
| 0-1"/0-25mm, Non-Rotating | 64 |
| 0-1/4"..... | 66 |
| 0-1/2"..... | 67 |
| 0-1/2"/0-13mm..... | 66 |
| 0-1/2", Non-Rotating Spindles | 63 |
| 0-1/2", Stainless Steel | 67 |
| 0-1/4"/0-6.5mm..... | 66 |
| 0-1", Digital..... | 69 |
| 0-1", Large, Super-Precision..... | 72 |
| 0-2"/0-50mm, Electronic | 65 |
| 0-2", Electronic..... | 65 |
| 0-2", Large, Direct-Reading | 71 |
| 0-2", Long Range..... | 69 |
| 0-1"..... | 68 |
| Speeds Gaging..... | 42 |
| Indicating..... | 73 |
| Inside..... | 77–82 |
| Combination Head with Inside Micrometer | 78 |
| End Measuring Rods | 77–78 |
| Heads & Rods to 107" | 81 |
| Heads & Solid-Rods to 32" | 79 |
| Heads & Tubular Rods to 40" | 80 |
| Internal Groove..... | 82 |
| Internal Micrometers | 79 |
| Measuring Tips | 77 |
| Tubular | 80–81 |
| Measuring Rods | 76 |
| Mul-T Anvil..... | 43 |
| Outside | 28–30, 33–36 |
| Automotive Crankshaft | 48 |
| Automotive Disc Brake..... | 49 |
| Blade-Type | 51–52 |
| Can Curl..... | 61 |



| | |
|-------------------------------|-----------------------|
| Can Seam..... | 61 |
| Disc-Type | 53–54 |
| Groove..... | 49 |
| Hi-Precision | 32 |
| Hub..... | 62 |
| Insulated Frame | 32 |
| Interchangeable Anvil | 37–39, 38 |
| Paper Gage..... | 50 |
| Rounded Anvils | 55–56 |
| Screw Thread..... | 58–59 |
| Screw Thread Comparator | 59 |
| Sheet Metal | 45–46 |
| Special Function..... | 42–64 |
| Stainless Steel | 30 |
| Stand | 41 |
| Steel Mill | 57 |
| Tube..... | 47 |
| Tubular Bow Type | 39–40, 40 |
| Tubular Deep Throat | 42 |
| V-Anvil..... | 60 |
| Wire | 60 |
| Sets..... | 27, 33, 36–37, 78, 81 |

P

Parallels

| | |
|------------|-----|
| Steel..... | 303 |
|------------|-----|

Precision Angle Plate..... 356

Precision Granite Products..... 409–422

| | |
|---------------------------|-----|
| Angle Plates..... | 421 |
| Cleaner..... | 421 |
| Covers..... | 421 |
| Cubes..... | 420 |
| Master Squares..... | 419 |
| Parallels..... | 419 |
| Planekator Kits | 422 |
| Repeat Reading Gage | 422 |
| Stands | 417 |
| Cabinet..... | 417 |
| Straight Edges..... | 420 |
| Surface Plates | |
| Crystal Pink®..... | 414 |
| Superior Black..... | 416 |

| | |
|-------------------------|-----|
| Toolmakers' Flats | 418 |
| Tri-Squares | 418 |
| V-Blocks | 420 |

Precision Shop Tools..... 341–368

| | |
|----------------------------------|-----|
| Adjustable-Jaw Cut Nippers | 345 |
|----------------------------------|-----|

Protractors

| | |
|---------------------------|----------|
| Drill Point Gage | 309 |
| Non-Reversible Bevel..... | 310 |
| Reversible Bevel | 310 |
| Special Dial Heads..... | 308 |
| Steel..... | 307–308 |
| Universal Bevel..... | 306, 308 |
| Vernier Bevel..... | 306 |

Punches..... 349–353

| | |
|--------------------------------|---------|
| Automatic | 349 |
| Center | 349–350 |
| Drive Pin | 352 |
| Drive Pin, Brass..... | 352 |
| Drive Pin, Machine..... | 353 |
| Drive Pin, Machine, Brass..... | 353 |
| Hinge-Locating..... | 349 |
| Prick..... | 351 |
| Round Shank..... | 350 |
| Square-Head..... | 351 |

R

Reference Tables..... 577–592

Rules..... 283–301

| | |
|-----------------------------------|---------|
| Accessories | |
| Holder | 301 |
| Key Seat Clamps..... | 300 |
| Pocket Clip | 285 |
| English Pattern..... | 299 |
| Hook..... | 285 |
| Parallels..... | 304 |
| Steel..... | 301–302 |
| Decimal Equivalents | 298 |
| Draftsmen's..... | 302 |
| Folding, Circumference..... | 299 |
| General Utility..... | 299 |
| Letter & Number Drill Sizes | 298 |



| | | | |
|-----------------------------------|----------------|--|----------------|
| Precision | 284–297 | Tool and Instrument Oil..... | 366 |
| Shrink Graduations..... | 297 | Tool Sets | 221–222 |
| S | | Automotive..... | 222 |
| Screwdrivers | 354–355 | Basic Precision..... | 222 |
| Jewelers' | 354 | V | |
| Pocket | 355 | V-Blocks..... | 360–362 |
| Precision..... | 354 | Dual-Vee, Magnetic | 361 |
| Scribers | | Vises | |
| Adjustable Sleeve | 344 | Combination Hand | 363 |
| Improved..... | 344 | Pin..... | 358 |
| Pocket | 344 | Double End..... | 358 |
| Slide Calipers..... | 89–105 | Tapered | 358 |
| Electronic..... | 90 | Precision Grinding | 357 |
| Vernier..... | 103 | Vocational & Educational | 571–576 |
| Small Hole Gages..... | 320 | W | |
| Special Gaging..... | 251–264 | Webber Gage | 375–408 |
| Squares | 265–284 | Angle Gage Blocks..... | 399–400 |
| Diemakers' | 281–282 | Calibration | 406–407 |
| Double..... | 279–280 | Chamois | 405 |
| Heads | | croblox® Reflecting Cubes..... | 402–403 |
| Cast Iron..... | 268, 269 | Indicator Accessory Set..... | 389 |
| Center and Protractor | 270 | Internal Measuring Machine Jaws..... | 394 |
| Hardened Steel | 268–269 | MicroAccurate® | 382 |
| Master Precision..... | 277 | Optical Flats | 404 |
| Toolmakers' Stainless Steel | 278 | Polygons..... | 404 |
| Try..... | 278 | Reference Bars..... | 398–399 |
| Straight Edges | | Steel Internal Measuring Machine Jaws..... | 385 |
| Steel..... | 302 | Stones | 405 |
| T | | True Squares..... | 401 |
| Tachometer..... | 367 | Wear Blocks..... | 389 |
| Tap Wrenches | 359 | Wiggler/Center Finder..... | 346 |
| Testers | | Wireless Data Collection..... | 228 |
| Hardness | | | |
| Analog..... | 237, 238 | | |
| Compact..... | 242 | | |
| Digital..... | 239, 247 | | |
| Portable..... | 243–245 | | |
| Surface Roughness..... | 245–246 | | |
| TalyProfile..... | 246 | | |
| Thickness | 248–249 | | |

| | | | | | |
|----------------|---|----------|-------------|--|----------|
| 1 | Adjustable-Jaw Cut Nippers..... | 345 | 28 | Shock Absorbing Anvil | 165 |
| M1® | Industrial Quality All-Purpose Lubricant..... | 364 | 29 | Scratch Gage..... | 344 |
| 2 | Outside Micrometers | 29 | 33HC | Combination Squares | 269 |
| 2A | Outside Micrometers | 29 | 33H | Forged and Hardened Steel Heads | 268 |
| L2 Plus | Systems | 86–489 | 33J | Junior Combination Squares | 276 |
| L3 | Systems | 482–485 | 36 | Lock-Joint Transfer Calipers, Outside..... | 314 |
| 6 | Screw Pitch Gage..... | 332 | 37 | Lock-Joint Transfer Calipers, Inside | 314 |
| 8 | Large Combination Squares | 275 | 38 | Lock-Joint Calipers, Outside | 314 |
| 9 | Combination Squares | 271 | 39 | Lock-Joint Calipers, Inside | 314 |
| 9.MA1 | Mini-Metric Rectangular Steel Gage Block Set..... | 391 | 47 | Universal Bevel..... | 308 |
| 10 | Student Combination Squares..... | 275 | 50 | Trammels | 315 |
| 11H | Combination Squares | 268 | 54 | Hold-Downs..... | 356 |
| 11HC | Combination Squares | 269 | 55 | Master Precision Squares with Beveled Edges..... | 277 |
| 12 | Non-reversible Bevel Protractors | 310 | 56 | Small Surface Gages | 342 |
| 13 | Double Squares with hardened blades..... | 279 | 57 | Full-sized Surface Gages | 342 |
| 14 | Double Steel Squares | 280 | 57S | Universal Snugs | 143, 343 |
| 18 | Automatic Center Punches..... | 349 | 58S | Universal Snugs | 143, 343 |
| C19 | Steel Protractor | 307 | 59 | Trammels | 315 |
| 20 | Master Precision Squares | 277 | 61 | "Reliable" Try Square..... | 278 |
| 22C | Drill Point Gage | 309 | 62 | Rule Holder..... | 301 |
| 25 | Dial Indicators..... | 148, 155 | 63 | Long Range Micrometer Heads | 69 |
| 25 | Dial Indicators, Long Range..... | 158–159 | 66 | Thickness Gage | 336–337 |
| 25LC | Range Limit Cap | 167 | 67 | Improved Scriber..... | 344 |
| 25R | Contact Point Set | 166 | 68 | Adjustable Sleeve Scriber | 344 |
| 25SC | Split Collets..... | 167 | 70 | Pocket Scribers..... | 344 |
| 25W | Roller Indicator Contact Point..... | 166 | 73 | "Yankee" Inside Calipers..... | 312 |
| 26 | Firm-Joint Calipers, Outside..... | 314 | 78XT | Bore Gages..... | 209–210 |
| 27 | Firm-Joint Calipers, Inside | 314 | 79 | "Yankee" Outside Calipers | 312 |



| | | | | | |
|--------------|--|---------|--------------|--|---------|
| 80 | Miniature Dial Indicators | 146 | 135 | Pocket Levels..... | 374 |
| 81 | Dial Indicators..... | 153–154 | 136 | Cross Test Level..... | 373 |
| 82 | Dial Bore Gages | 214 | 154 | Adjustable Parallels | 304 |
| 83 | "Yankee" Dividers..... | 312 | 155 | Screw Pitch Gage..... | 332 |
| 84 | Dial Bore Gages | 215 | 156 | International Metric Standard Screw Pitch Gages..... | 333 |
| 85 | Extension Dividers with Caliper Legs..... | 316 | 159 | International Metric Standard Screw Pitch Gages..... | 333 |
| 86 | Combination Hand Vise..... | 363 | SR160 | Surface Roughness Tester..... | 245 |
| 91 | Tap Wrenches..... | 359 | 160 | Toolmakers' Steel Clamps..... | 357 |
| 92 | Carpenters' Dividers..... | 316 | 161 | Toolmakers' Parallel Clamps | 356 |
| 93 | T-Handle Tap Wrenches | 359 | 162 | Pin Vises..... | 358 |
| 98 | Machinists' Levels..... | 371 | 165 | Double End Pin Vise | 358 |
| C100F | Steel Rules | 297 | 166 | Pin Vises..... | 358 |
| 110 | Gage Holder..... | 334 | 167 | Gage Holders | 334 |
| 117 | Center Punches | 350 | S167 | Gage Holders | 334 |
| 119 | Bench Blocks..... | 348 | SD167 | Gage Holders | 334 |
| 120B | Dial Calipers with Long Nib Jaws..... | 99 | 170 | Dial Sheet Gages..... | 187 |
| 120 | Dial Calipers | 96 | 172 | Thickness Gages..... | 336–337 |
| 120J | Offset Dial Caliper | 99 | 174 | Tap Wrench | 359 |
| 121 | Long Range Tubular Inside Micrometer Sets..... | 81 | 178 | Fillet or Radius Gages..... | 330 |
| 123 | Master Vernier Calipers..... | 100 | C182 | Steel Protractor | 307 |
| 124 | Inside Micrometers..... | 79 | C183 | Steel Protractor | 307 |
| 125 | Vernier Calipers..... | 103 | 185 | Time Saver® Tap and Drill Gage..... | 327 |
| 128 | Inside Micrometers..... | 78 | 186 | Drill and Steel Wire Gage | 327 |
| 128 | Micrometer Sets..... | 78 | 187 | Jobbers' Drill Gage - Hardened | 327 |
| 129 | Bench Blocks..... | 348 | 188 | English Standard Wire Gage..... | 328 |
| 130 | Bench Level..... | 374 | 190 | "Little Giant" Jack Screws..... | 347 |
| 132 | Precision Bench Levels..... | 372 | 191 | "Little Giant" Jack Screws..... | 347 |
| 134 | Cross Test Level and Plumb | 373 | 193 | Steel Protractor | 308 |



| | | | | | |
|--------------|---|-------|---------------|------------------------------------|-------|
| 196 | Universal Back-Plunger Dial Indicators..... | 142 | C251 | Trammels and Attachments..... | 317 |
| 198 | Standard Letter Size Drill Gage..... | 327 | 252 | Height Transfer Gages | 120 |
| 199 | Master Precision Level..... | 370 | 253 | Dial Indicator Sets | 156 |
| 207 | Can Seam Outside Micrometers | 61 | 254 | Master Vernier Height Gages..... | 114 |
| 208 | Can Seam Outside Micrometers | 61 | 255EM | Vernier Height Gages..... | 115 |
| 209 | Can Curl Micrometers..... | 61 | 255 | Vernier Height Gages..... | 115 |
| 210 | Screw Thread Comparator Outside Micrometers..... | 59 | 256 | Disc-Type Outside Micrometers..... | 53 |
| 211 | Rounded Anvil Outside Micrometers | 55 | 257 | Surface Gages | 342 |
| 216 | Digital Micrometers | 27–28 | 258 | DIGI-CHEK™ Height Gages | 118 |
| 220 | Mul-T-Anvil Outside Micrometers | 43 | 258R | Riser Blocks..... | 119 |
| 222 | Sheet Metal Outside Micrometers..... | 45 | 258RRB | Reverse Reading Blocks | 119 |
| 223 | Paper Gage Outside Micrometers..... | 50 | 260 | Groove Outside Micrometers..... | 49–50 |
| 224.1 | Mechanical Interchangeable Anvil Micrometers..... | 37 | 261 | Micrometer Heads..... | 63 |
| 225 | Wire Micrometers..... | 60 | 262 | Micrometer Heads..... | 64 |
| 226 | Outside Micrometers | 33 | 263 | Micrometer Heads..... | 68 |
| 228 | Hub Outside Micrometer..... | 62 | 264 | Center Punches | 350 |
| 229 | Telescoping Gages | 321 | 267 | Taper Gage | 323 |
| 230 | Outside Micrometers | 28 | 268 | V-Blocks and Clamp..... | 360 |
| 231 | Outside Micrometers | 32 | 269 | Taper Gages | 323 |
| 232 | Outside Micrometers | 28 | 271 | V-Blocks and Clamp..... | 360 |
| 234 | End Measuring Rods | 76 | 272 | Fillet or Radius Gages..... | 330 |
| 236 | Depth and Angle Gages | 129 | 274 | Toolmakers' Inside Calipers..... | 312 |
| 237 | Steel Rule Depth Gages..... | 128 | 275 | Toolmakers' Outside Calipers..... | 312 |
| 240 | Pin Vises..... | 358 | 277 | Toolmakers' Dividers | 312 |
| 243 | Hermaphrodite Calipers | 313 | 278 | V-Blocks and Clamps | 360 |
| 245 | Engineers' Taper, Wire and Thickness Gage..... | 339 | 279 | Fillet or Radius Gages..... | 330 |
| 247 | Micrometer Ball Attachments | 57 | 280 | Piano Tuners' Gage | 328 |
| 248 | Drive Pin Punches | 353 | 281 | American Standard Wire Gage | 328 |



| | | | | | |
|----------------|---|--------------|---------------|---|---------|
| 283 | U.S. Standard Gage..... | 328 | C374 | Steel Rules | 297 |
| 284 | Acme Standard Screw Thread Gage - Hardened..... | 329 | C375 | Steel Rules | 297 |
| 286 | Drill and Steel Wire Gage | 328 | C376 | Steel Rules | 297 |
| 287 | American Steel & Wire Co. Gage | 328 | C377 | Steel Rules | 297 |
| 289 | Attachment for Combination Squares | 274 | C378 | Steel Rules | 297 |
| 298 | Key Seat Clamps..... | 300 | 380 | Steel Straight Edges | 302 |
| 299 | Rule Clamp..... | 300 | 384 | Steel Parallels..... | 303 |
| SR300 | Surface Roughness Tester..... | 245 | 385 | Steel Straight Edges, Bevel Edge..... | 302 |
| C303R | Steel Rules | 288 | 386 | Draftsmen's Steel Straight Edges with Bevel Edge..... | 302 |
| C303SR | Steel Rules..... | 288, 290–291 | 387 | Steel Straight Edges, Bevel and Graduated Edge..... | 302 |
| C304R | Steel Rules..... | 288, 290–291 | C389 | Steel Rules | 297 |
| C304SRE | Steel Rules..... | 288, 290–291 | C396 | Center Gage | 331 |
| C305R | Steel Rules..... | 288, 290–291 | C398 | Center Gage | 331 |
| C306R | Steel Rules | 288, 290 | SR400 | Surface Roughness Tester..... | 245 |
| C309R | Steel Rules | 288 | 401 | High Carbon, High Chromium Flat Stock | 561 |
| C310K | Steel Rules with Pocket Clip..... | 288 | 402 | High Carbon, High Chromium Flat Stock | 561–562 |
| C310R | Steel Rules | 288, 290 | C404R | Steel Rules | 291–292 |
| C310T | Tapered Steel Rules..... | 288 | CH404R | Steel Rules | 291–292 |
| C316R | Steel Rules..... | 288, 290–291 | 414 | Steel Rules, English Pattern | 299 |
| C330 | Steel Rules | 294 | C416R | Steel Rules | 291–292 |
| C331 | Steel Rules | 296 | CH416R | Steel Rules | 291–292 |
| C334 | Steel Rules | 296 | 423 | Small Steel Rules with Holder..... | 301 |
| C335S | Steel Rules | 294 | 424 | Stainless Steel Pocket Slide Calipers | 105 |
| 344 | A6 Air Hardening Flat Stock | 559–560 | 430 | Indicating Micrometer | 73 |
| 359 | Universal Bevel Protractors | 306 | 434 | Combination Squares | 270 |
| 363 | Digital Micrometer Heads..... | 69 | 435 | Square, Center and Protractor Head | 270 |
| C368 | Steel Rules | 297 | 436.1 | Outside Micrometers | 34–38 |
| C370 | Steel Rules | 297 | 436 | Automotive Crankshaft Outside Micrometers..... | 48 |



| | | | | | |
|-------------|---|-----|--------------|---|----------|
| 439 | Builders' Combination Tool..... | 276 | 480 | Oil Hardening Drill Rod, O1 | 565–566 |
| 440 | Depth Micrometers..... | 86 | 481 | Water Hardening Drill Rod, W1 | 567–568 |
| 443 | Micrometer Depth Gages with Half Base | 87 | 483 | V-Anvil Outside Micrometers..... | 60 |
| 445 | Depth Micrometers..... | 86 | 484 | Screw Pitch Gage..... | 332 |
| 446 | Digital Micrometer Depth Gages..... | 84 | 485 | V-Anvil Micrometers | 60 |
| 448 | Vernier Depth Gages | 128 | 486 | Blade Type Outside Micrometers | 51 |
| 449 | Micrometer Depth Gages..... | 85 | 490 | Reversible Bevel Protractors..... | 310 |
| 450 | Dial Depth Gages | 127 | 491 | Reversible Bevel Protractors..... | 310 |
| 452 | Cylinder Gages..... | 196 | C493B | Protractor and Depth Gages..... | 309 |
| 453 | Diemakers' Squares | 281 | C493 | Protractor and Depth Gages..... | 309 |
| 456 | Gear Tooth Vernier Calipers | 104 | 493 | Protractor and Depth Gages..... | 309 |
| 457 | Diemakers' Square..... | 282 | 495 | Oil Hardening Flat Stock | 552, 555 |
| 458 | Automotive Disc Brake Outside Micrometers | 49 | 496 | Oil Hardening Flat Stock | 552–554 |
| 460B | Micrometer Heads..... | 66 | 497 | Air Hardening Flat Stock | 556–557 |
| 460 | Micrometer Heads..... | 66 | 498 | Low Carbon Flat Stock..... | 563–564 |
| 463 | Micrometer Heads..... | 67 | 499 | Air Hardening Flat Stock | 556, 558 |
| 464 | Micrometer Heads..... | 66 | 551 | Precision Screwdrivers | 354 |
| 465 | Micrometer Heads..... | 71 | 553 | Pocket Screwdrivers..... | 355 |
| 466 | Angle Gage..... | 331 | 555 | Jewelers' Screwdrivers..... | 354 |
| 467 | Thickness Gage | 336 | 563 | Firm-Joint Hermaphrodite Calipers | 313 |
| 468 | Micrometer Heads..... | 71 | 565 | Drive Pin Punches | 352 |
| 469 | Micrometer Heads..... | 72 | 566 | Dual-Vee Magnetic V-Block..... | 361 |
| 471 | Steel Folding Rule, Circumference | 299 | 567 | V-Block and Clamp..... | 362 |
| 472 | Screw Pitch Gage..... | 333 | 568 | V-Blocks and Clamps | 361 |
| 473 | Screw Pitch Gage..... | 333 | 569 | Tube Outside Micrometers | 47 |
| 474 | Screw Pitch Gage..... | 332 | 572 | Thickness Gage | 336 |
| 476 | Screw Pitch Gage..... | 333 | 575 | Screw Thread Outside Micrometers | 58 |
| 476 | Whitworth Standard Screw Pitch Gages | 333 | 576 | Rounded Anvil Outside Micrometers | 55 |



| | | | | | |
|----------------|--|---------|--------------|---|----------|
| 577 | Rounded Anvil Outside Micrometers | 55 | C637 | Steel Rules | 294 |
| 578 | V-Block and Clamp for Larger Capacity Work | 362 | C637E | Steel Rules | 294 |
| 579 | Telescoping Gages | 322 | 640 | Dial Depth Gages | 130 |
| 580 | Precision Angle Plate | 356 | 642 | Top Reading Dial Depth Gages | 132 |
| 581 | Precision Grinding Vise | 357 | 643 | Dial Depth Gage | 130 |
| 585 | Screw Thread Outside Micrometers | 58 | 644 | Dial Depth Gages | 131 |
| C601 | Steel Rules | 289–290 | 647 | Dial Comparator Indicators | 162 |
| 604R | Steel Rules | 289–290 | 648 | Depth Gage Bases | 131 |
| C604R | Steel Rules | 288–292 | 648 | Depth Gage Bases with Stem Collet | 167 |
| CD604R | Steel Rules | 289–290 | 649 | Spindle Squares | 188 |
| CH604R | Steel Rules | 289–292 | 650 | Back-Plunger Dial Indicators | 141 |
| DH604R | Steel Rules | 289–290 | 651 | Back Plunger Dial Indicators | 141 |
| C604RE | Steel Rules | 289–290 | 653 | Dial Comparators | 184 |
| H604R | Steel Rules | 289–290 | 653G | Dial Comparators | 184 |
| C606R | Steel Rules | 289–290 | 655 | Dial Indicators | 148, 156 |
| C607R | Steel Rules | 289–292 | 655 | Dial Indicators, Long Range | 158–159 |
| 610N | Steel Rules | 289–290 | 656 | Dial Indicators | 148, 157 |
| C610N | Steel Rules | 289–290 | 656 | Dial Indicators, Extra Long Range | 160 |
| CH610N | Steel Rules | 289 | 656 | Dial Indicators, Long Range | 158 |
| H610N | Steel Rules | 289–290 | 657-1 | Magnetic Base Universal Indicator Holder | 180 |
| 611N | Steel Rules | 289 | 657-2 | Magnetic Base Universal Indicator Holder | 180 |
| C616R | Steel Rules | 289–290 | 657AA | Magnetic Base Indicator Holder | 177 |
| C622R-6 | Steel Rule, Decimal Equivalents | 298 | 657A | Magnetic Base Indicator Holder | 178 |
| C635 | Steel Rules | 294 | 657 | Indicator Holders | 176 |
| C635E | Steel Rules | 294 | 657T | Flex-O-Post Indicator Holders | 179 |
| 635N | Steel Rules | 294 | 659 | Heavy-Duty Magnetic Base Indicator Holder | 181 |
| C636EM | Steel Rules | 296 | 660 | Magnetic Base Indicator Holder | 180 |
| C636ME | Steel Rules | 296 | 661 | Mini Magnetic Indicator Holder | 181 |



| | | | | | |
|------------|---|-----|---------------|--|---------|
| 663 | Heavy Duty Micrometer Heads | 70 | 717 | Electronic Gage Amplifier | 232 |
| 665 | Inspection Holder and Dial Indicators | 183 | 724 | Tubular Outside Micrometers | 39 |
| 666 | Thickness Gages/"Feeler" Stock..... | 337 | 725 | Deep Throat Tubular Micrometer | 42 |
| 667 | Thickness Gages/"Feeler" Stock..... | 338 | 733 | Electronic Micrometers (w/ output) | 26 |
| 668 | Shaft Alignment Clamp Sets..... | 194 | 736 | Tubular Outside Micrometers | 40 |
| 670 | Indicator Hole Attachment..... | 164 | 749 | Electronic Micrometer Depth Gage | 83 |
| 671 | Universal Attachment..... | 164 | 756 | Electronic Disc-Type Micrometers..... | 54 |
| 673 | Bench Micrometers | 75 | 760 | Electronic Screw Thread Comparator Micrometer | 59 |
| 675 | Dial Comparators | 184 | 762 | Micrometer Heads..... | 65 |
| 683 | Internal Chamfer Gages | 185 | 764 | Electronic Sheet Metal Micrometers | 46 |
| 684 | Internal Chamfer Gages | 185 | 765A | Electronic Snap Gage | 189 |
| 685 | External Chamfer Gages | 185 | S766 | Basic Electronic Tool Sets | 222 |
| 686 | External Chamfer Gages | 185 | 769 | Electronic Tube Micrometers | 47 |
| 687 | Countersink Gages, 82° | 186 | 770BXT | Electronic Internal Micrometers..... | 207–208 |
| 688 | Countersink Gages, 90° | 186 | 776 | Gage-Chek™ | 234 |
| 689 | Countersink Gages, 100° | 186 | 777 | Electronic Bench Micrometers..... | 74 |
| 696 | Crankshaft Distortion Dial/Strain Gage | 195 | 781BXT | AccuBore® Electronic Bore Gages | 204–206 |
| 697 | Inside Dial Gages | 193 | 786 | Electronic Blade-Type Outside Micrometers | 52 |
| 700 | Inside Micrometer Calipers | 82 | 788 | Rounded Anvil Outside Micrometers | 56 |
| 701 | Internal Groove Micrometers | 82 | 790 | Electronic Multi-Anvil Outside Micrometers | 44 |
| 706 | Inspection Blocks | 366 | 795.1 | Electronic Micrometers (w/ output) | 24 |
| 707 | Steel Internal Measuring Machine Jaws..... | 385 | 796.1 | Electronic Micrometers | 24 |
| 708 | Dial Test Indicators with dovetail mounts..... | 135 | 798 | Electronic Calipers..... | 90 |
| 709 | Dial Test Indicators with dovetail mounts..... | 135 | 800 | Square-Head Nail Sets | 351 |
| 711 | Last Word® Dial Test Indicators..... | 138 | 806D | Thickness Gage or "Feeler" Stock Holders | 339 |
| 714 | Electronic Interchangeable Anvil Outside Micrometers..... | 38 | 806 | Thickness Gage Holders | 339 |
| 715 | Electronic Gage Amplifier Gage Heads | 236 | 811 | Dial Test Indicators with swivel head..... | 136 |
| 716 | Indicator Testers..... | 169 | 815 | Toolmakers' Hammer | 348 |



| | | | | | |
|--------------|--|-----|----------------|---|---------|
| 816 | Prick Punches..... | 351 | 1309R | Steel Rules | 288 |
| 818 | Automatic Center Punch with Adjustable Stroke..... | 349 | 1317 | Decimal Equivalents Card | 575 |
| 819 | Automatic Center Punches..... | 349 | 1318 | Metric Equivalents Card..... | 575 |
| 823 | Tubular Inside Micrometers | 80 | 1463 | Micrometer Heads..... | 67 |
| 824 | Inside Micrometers..... | 81 | 1604R | Steel Rules | 289–290 |
| 827 | Edge Finders..... | 346 | 1610 | Kleenscribe™ Layout Dye | 345 |
| 828 | Wiggler/Center Finder..... | 346 | 1612 | Rule Case..... | 289 |
| 829 | Small Hole Gages..... | 320 | 1620 | Tool and Instrument Oil..... | 366 |
| 830 | Small Hole Gages..... | 320 | 1634 | Rule Case | 289 |
| 831 | Small Hole Gages..... | 320 | 1700 | The Starrett Book for Student Machinists | 576 |
| S909 | Basic Precision Measuring Tool Sets..... | 222 | 1702 | Wall Size Educational Charts | 576 |
| 1010 | Dial Indicator Pocket Gages | 189 | 2000 | Altissimo® Electronic Height Gages..... | 108 |
| 1015 | Portable Dial Thickness Gages | 190 | 2700 | Backlight Electronic Indicators..... | 171 |
| 1017 | Outside Dial Caliper Gages..... | 193 | 2700 | Wisdom® Electronic Indicators | 172 |
| 1019 | Internal Dial Caliper Gages..... | 193 | 2900 | Electronic Indicators | 170 |
| 1025 | Stainless Steel Pocket Slide Calipers | 105 | 3020 | Toolmakers' Grade Stainless Steel Squares..... | 278 |
| 1100 | Heavy-Duty Dial Indicator Diameter Gages | 200 | 3089 | Dial Bore Gages | 213 |
| 1101 | Dial Indicator Diameter Gages | 199 | 3202 | Dial Calipers | 98 |
| 1102 | Dial Indicator Diameter Gages | 198 | 3206 | Outside Micrometer Stand | 41 |
| 1126 | Setting Masters for 1100, 1101 Diameter Gages..... | 202 | 3250 | Dial Height Gage | 116 |
| 1127 | Setting Master for 1102 Diameter Gages..... | 201 | 3259-AC | Digital Height Gage Scriber Carrier Holder..... | 121 |
| 1150 | Dial Indicator Snap Gages..... | 191 | 3600 | Electronic Indicators | 174 |
| 1175 | Dial Indicator Groove Gages | 192 | 3671 | Indicator Stand..... | 175 |
| 1202F | Fractional Dial Calipers | 98 | 3672 | Indicator Stand..... | 175 |
| 1212 | Stainless Steel Outside Micrometers..... | 30 | 3673 | Indicator Stand..... | 175 |
| 1213 | Precision Tool Poster | 573 | 3732 | Electronic Micrometers | 25 |
| 1230 | Stainless Steel Outside Micrometers..... | 30 | 3751 | Electronic Height Gage | 111 |
| 1263 | Stainless Steel Micrometer Heads | 68 | 3753A | Electronic Depth Gages | 125 |



| | | | |
|---|---------|--|---------|
| 3753B Electronic Depth Gages | 126 | AV350+ Automatic Vision Metrology System | 434–435 |
| 3754 Electronic Height Gages..... | 112 | AVR200 Automatic Vision Metrology System | 430–431 |
| 3805 Electronic Durometer | 247 | AVR300 Automatic Vision Metrology System | 430–431 |
| 3808 Dial Test Indicators | 140 | B248 Brass Drive Pin Punches..... | 353 |
| 3809 Dial Test Indicators | 140 | B565 Brass Drive Pin Punches..... | 352 |
| 3810A Digital Portable Hardness Tester | 243 | C391 Center Gage | 331 |
| 3811 Portable Hardness Tester | 242 | C623R-6 Steel Rule with Letter and Number Drill Sizes.... | 298 |
| 3812 Ultrasonic Thickness Gage | 248 | D1 Inspection Software..... | 480 |
| 3813 Coating Thickness Gage | 249 | EC799 Electronic Calipers..... | 91 |
| 3814 Analog Bench Hardness Tester..... | 237 | FLC Load Cell Sensor | 513 |
| 3815 Twin Analog Bench Hardness Tester | 238 | HB400 Horizontal Bench Optical Comparator..... | 452–453 |
| 3816 Digital Bench Motorized Hardness Tester | 239 | HD400 Horizontal Bench-Top Optical Comparator | 454–455 |
| 3908 Dial Test Indicators | 140 | HDV300 Horizontal Digital Video Comparator | 438–439 |
| 3909 Dial Test Indicators | 140 | HDV400 Horizontal Digital Video Comparator | 438–439 |
| S4000 Pin Gages..... | 326 | HE400 Horizontal Bench Optical Comparator..... | 450–451 |
| 5000 Carbon Fiber Calipers | 92 | HF600 Horizontal Floor Standing Optical Comparator..... | 462–463 |
| 5001 Carbon Fiber Calipers | 92 | HF750 Horizontal Floor Optical Comparator..... | 464–465 |
| 5002 Carbon Fiber Calipers | 92 | HS600 Side Bed Optical Comparator | 466–467 |
| 5004 Electronic Depth Gages | 124 | HS750 Side Bed Optical Comparator | 468–469 |
| 5005 Electronic Long Jaw Calipers | 94 | L2 Material Testing & Force Measurement System | 490–493 |
| 5006 Electronic Groove Calipers | 95 | M1 MetLogix™ | 476 |
| 7612 4-Port GageMux USB | 229 | M3 MetLogix™ | 477 |
| 7613 4-Port GageMux USB | 229 | MV300 Manual Vision Metrology System | 424–425 |
| S7793Z Digital Tachometer | 367 | MVR200 Manual Vision Metrology System | 426–427 |
| A2 482 Air Hardening Drill Rod, A2..... | 569 | MVR300 Manual Vision Metrology System | 426–427 |
| AV300 Automatic Vision Metrology System | 428–429 | QC100 Quadra-Chek® | 478 |
| AV300+ Automatic Vision Metrology System | 432–433 | QC200 Quadra-Chek® | 478 |
| AV350 Automatic Vision Metrology System | 428–429 | QC5200 Quadra-Chek® | 479 |



| | | |
|---------------|---|---------|
| QC5300 | Quadra-Chek® | 479 |
| S2 | Material Testing & Force Measurement System | 494–497 |
| S216 | Digital Micrometer Set | 27 |
| S226 | Micrometer Sets | 33 |
| S436.1 | Micrometer Sets with Standards | 36–37 |
| S898Z | Automotive Inspection Sets | 222 |
| T444 | Outside Micrometer | 31 |
| ULC | Load Cell Sensor | 512 |
| VB300 | Vertical Bench Optical Comparator | 456–457 |
| VB400 | Vertical Bench Optical Comparator | 458–459 |
| VF600 | Vertical Floor Standing Optical Comparator | 460–461 |



CONTACT INFORMATION GUIDE FOR NORTH AMERICA

COMPLETE, UP-TO-DATE CONTACT INFORMATION AVAILABLE AT STARRETT.COM

PRIMARY CONTACTS, SALES AND GENERAL INFORMATION

- **World Headquarters and Precision Tools:**
Athol, MA, (978) 249-3551
- **Metrology Equipment:**
Laguna Hills, CA, (949) 348-1213
- **Laser Measurement:**
Columbus, GA, (706) 323-5142
- **Granite Surface Plates and Accessories:**
Waite Park, MN, (320) 251-7171
- **Gage Blocks:**
Cleveland, OH, (440) 835-0001
- **Mexico:**
Saltillo, Coah, Mexico, (844) 432-4660

CALIBRATION

- **Precision Tools and Gages:**
Athol, MA, (978) 249-3551
- **Starrett Calibration Services:**
Duncan, SC, (864) 433-8407
- **Metrology Equipment:**
Laguna Hills, CA, (949) 348-1213
- **Granite Surface Plates and Accessories:**
Waite Park, MN, (320) 251-7171
- **Gage Blocks:**
Cleveland, OH, (440) 835-0001
- In Mexico, please call (844) 432-4660

REPAIR

- **Precision Tools and Gages:**
Athol, MA, (978) 249-3551
- **Metrology Equipment:**
Laguna Hills, CA, (949) 348-1213
- **Granite Surface Plates and Accessories:**
Waite Park, MN, (320) 251-7171
- **Gage Blocks:**
Cleveland, OH, (440) 835-0001
- In Mexico, please call (844) 432-46-60

CUSTOM SOLUTION DEVELOPMENT

- **Special Tools and Gages:**
Athol, MA, (978) 249-3551
- **Metrology System Development and Configuration:**
Laguna Hills, (949) 348-1213
- **Granite Based Custom Products:**
Waite Park, MN, (320) 251-7171
- In Mexico, please call (844) 432-4660

ADDITIONAL AND/OR UP-TO-DATE INFORMATION

- starrett.com
- Product Literature and Educational Materials:
Select the "Catalogs" button at starrett.com to order printed product information and to access literature PDFs for viewing and/or downloading
- In Mexico, please call (844) 432-4660

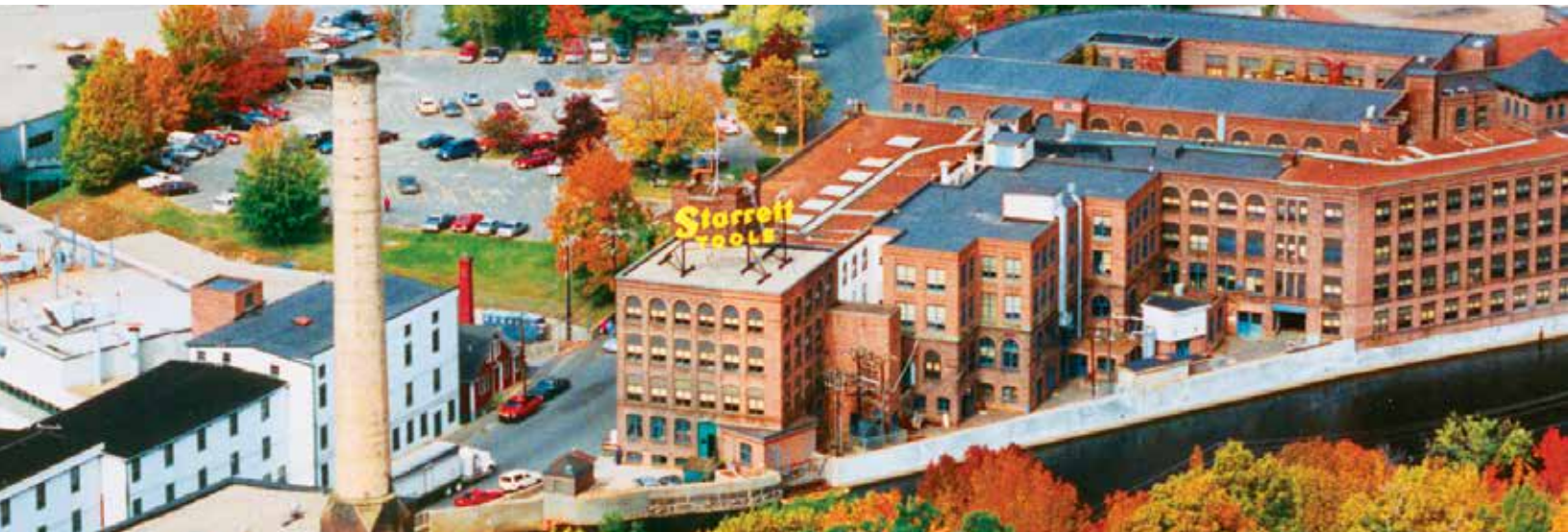

**CORPORATE HEADQUARTERS AND
MAIN FACTORY**

THE L.S. STARRETT COMPANY

121 Crescent Street
Athol, MA 01331-1915 - U.S.A.

Tel: (978) 249-3551
Main Fax: (978) 249-8495

INTERNATIONAL LOCATIONS

BRAZIL

Starrett Indústria e Comércio Ltda.
Av. Larooy S. Starrett 1880 - Bairro Pinheirinho
Caixa Postal 171
13306-900 Itu, São Paulo - Brazil

Tel: 55 11 2118-8200
Fax: 55 11 2118-8003

SCOTLAND

The L.S. Starrett Company Ltd.
Jedburgh TD8 6LR - Scotland

Tel: 44 (0) 1835 863501
Fax: 44 (0) 1835 863018

CHINA

Starrett Tools (Suzhou) Company Limited
Suzhou Industrial Park
No. 339. Su Hong Zhong Road
Suzhou, Jiangsu Province
P.R. China 215021

Tel: 86 512 6741940
Fax: 86 512 67415697



HOW TO ORDER

For prompt delivery, technical support and assistance, contact your nearest industrial distributor.

PRODUCT DEMONSTRATION

All Starrett manufacturing and branch locations and many distributors can demonstrate an array of Starrett products at work. Contact your local distributor to learn more.



STARRETT PRODUCT LINES

Band Saw Blades

Force Measurement

Jobsite & Workshop Tools

Laser Measurement

Metrology Equipment

Precision Granite

Precision Ground Solutions

Precision Measuring Tools

PTA & Hand Tools

Service

Webber Gage Blocks



Follow us!



starrett.com

Starrett®

Phone: (978) 249-3551 | Fax: (978) 249-8495
121 Crescent Street-Athol, MA 01331-1915-USA

Catalog 33 Precision Tools 09/17 30M/Q The L.S. Starrett Company 2014© Specifications subject to change.